



A MITEL
PRODUCT
GUIDE

Unify OpenScape 4000

System Components

Service Documentation

01/2026

Notices

The information contained in this document is believed to be accurate in all respects but is not warranted by Mitel Europe Limited. The information is subject to change without notice and should not be construed in any way as a commitment by Mitel or any of its affiliates or subsidiaries. Mitel and its affiliates and subsidiaries assume no responsibility for any errors or omissions in this document. Revisions of this document or new editions of it may be issued to incorporate such changes. No part of this document can be reproduced or transmitted in any form or by any means - electronic or mechanical - for any purpose without written permission from Mitel Networks Corporation.

Trademarks

The trademarks, service marks, logos, and graphics (collectively "Trademarks") appearing on Mitel's Internet sites or in its publications are registered and unregistered trademarks of Mitel Networks Corporation (MNC) or its subsidiaries (collectively "Mitel), Unify Software and Solutions GmbH & Co. KG or its affiliates (collectively "Unify") or others. Use of the Trademarks is prohibited without the express consent from Mitel and/or Unify. Please contact our legal department at iplegal@mitel.com for additional information. For a list of the worldwide Mitel and Unify registered trademarks, please refer to the website: <http://www.mitel.com/trademarks>.

© Copyright 2026, Mitel Networks Corporation

All rights reserved

Contents

1 Hardware	13
2 Important Information	14
2.1 Environmental and Operating Conditions	14
2.2 LAN with DC Voltage	14
2.3 Lightning Protection	14
3 OpenScale EcoServer	16
3.1 External Interfaces	17
3.1.1 EcoServer (Front Panel)	17
3.1.2 EcoServer (Rear Panel)	17
3.1.3 Interface, Display and LED descriptions (Front Panel)	18
3.1.4 Interface, Display and LED descriptions (Rear Panel)	19
3.2 Power Supply	21
3.3 Fan Control	21
3.4 Replacement of Components	21
3.4.1 Replacing Power Supply	22
3.4.2 Replacing SSD Tray	23
3.4.3 Removing Empty Tray	23
3.4.4 Replacing RTC (Real Time Clock) Battery	23
3.4.5 Replacing defect server	25
4 OpenScale EcoBranch	26
4.1 External Interfaces	26
4.1.1 OpenScale EcoBranch (Front Panel)	26
4.1.2 OpenScale EcoBranch (Rear Panel)	27
4.1.3 Interface, Display and LED descriptions (Front Panel)	28
4.2 Power Supply	28
4.3 Grounding	29
4.4 Fan Control	30
4.5 OpenScale EcoBranch modules	30
4.6 Compatible Products	30
5 SHELF FRUs	31
5.1 AP 3700-13 Shelf	31
5.1.1 Shelf Population (Front)	31
5.1.2 Shelf Population (Back) with Patch Panels	32
5.1.3 Shelf Population (Back) without Patch Panels	32
5.1.4 AP 3700-13 Backplane Connections	33
6 Boards	35
6.1 DIUT2	35
6.1.1 Functional Description	35
6.1.2 Systems Supported	35
6.1.3 Hardware	36
6.1.3.1 Hardware Variants	36
6.1.3.2 LED statuses and their meanings	36
6.1.3.3 Power supply	37
6.1.3.4 DIUT2 Interfaces	37
6.1.3.5 Cables and Adapters	40
6.1.4 Board substitution	41
6.1.5 Configuring DIUT2 board in the AMO BCSU	42

Contents

6.1.6 Removing the DIUT2 Board.....	43
6.1.7 Replacing the DIUT2 Board.....	44
6.1.8 Verifying the DIUT2 Board.....	44
6.2 DIUT3.....	44
6.2.1 Functional Description.....	45
6.2.2 Systems Supported.....	45
6.2.3 Hardware.....	45
6.2.3.1 Hardware Variants.....	46
6.2.3.2 LED status and their meanings.....	46
6.2.3.3 Power supply.....	47
6.2.3.4 DIUT3 Interfaces.....	47
6.2.3.5 Cables and Adapters.....	50
6.2.4 Board substitution.....	51
6.2.5 Configuring DIUT3 board in the AMO BCSU.....	52
6.2.6 Removing the DIUT3 Board.....	52
6.2.7 Replacing the DIUT3 Board.....	53
6.2.8 Verifying the DIUT3 Board.....	54
6.3 LTUCR.....	54
6.3.1 LEDs.....	55
6.3.2 Part Number.....	55
6.3.3 Use in Extended Shelves.....	55
6.3.4 Cable Types.....	55
6.3.5 Hardware Concept (Application Scenarios).....	56
6.3.6 Power Supply.....	56
6.3.7 Loadware.....	56
6.4 SIUX3.....	57
6.4.1 LED Indications.....	58
6.4.2 Removing the SIUX Board.....	58
6.4.3 Replacing the SIUX Board.....	59
6.4.4 Verifying the SIUX Board.....	59
6.5 SLMAV.....	60
6.5.1 Functional description.....	60
6.5.2 LED Indications.....	62
6.5.2.1 Function under FW.....	63
6.5.2.2 Function under LW.....	63
6.5.3 Removing SLMAV Board.....	64
6.5.4 Replacing SLMAV Board.....	64
6.5.5 Verifying the SLMAV Board.....	65
6.5.6 MDF Assignments.....	65
6.6 SLMU.....	71
6.6.1 Board Variants.....	71
6.6.2 LED Indications.....	72
6.6.3 Interfaces.....	72
6.6.4 Power Supply.....	72
6.7 SLMC.....	72
6.7.1 Board Variants.....	72
6.7.2 LED Indications.....	73
6.7.3 Interfaces.....	73
6.7.4 Power Supply.....	74
6.8 STMD3.....	74
6.8.1 Board Variants.....	75
6.8.2 LED Indications.....	75
6.9 STMIX.....	75
6.9.1 System Diagram.....	76
6.9.2 Board Variants and Modules.....	76
6.9.3 LED Displays and Interfaces.....	76

6.9.4 Power Supply.....	77
6.9.5 Restrictions.....	78
6.10 How to recover a STMIX board.....	78
6.10.1 General description.....	78
6.10.2 Preparing the necessary files.....	79
6.10.3 Tool configuration for flashing.....	80
6.10.4 STMIX USB configuration.....	84
6.10.5 STMIX re-flash.....	86
6.11 STMIY.....	92
6.11.1 System Diagram.....	93
6.11.2 Board Variants and Modules.....	94
6.11.3 LED Displays and Interfaces.....	94
6.11.4 Power Supply.....	95
6.11.5 Restrictions.....	95
6.12 How to reset a STMIY board.....	96
6.12.1 General description.....	96
6.13 TMANI.....	97
6.13.1 Functional Description.....	97
6.13.2 Systems Supported.....	98
6.13.3 Hardware Variants.....	98
6.13.4 Pin Assignment.....	99
6.13.5 Example for configuring the TMANI Board (Germany).....	106
6.13.6 PTIMES.....	107
6.14 TMEW2.....	115
6.14.1 Functions and Features for Target Countries.....	115
6.14.2 Description of Interfaces.....	115
6.14.3 LED Indications.....	116
6.14.4 Configuring the Board.....	116
6.14.5 Connector Pin Assignments.....	118
6.14.6 Removing the TMEW2 Board.....	120
6.14.7 Replacing the TMEW2 Board.....	120
6.14.8 Verifying the TMEW2 Board.....	121
7 OpenScape Access Modules.....	122
7.1 Important information.....	122
7.2 Reference Clock.....	123
7.3 X-Link Network.....	124
7.4 OpenScape Access Module Variants.....	125
7.4.1 OpenScape Access PRI.....	125
7.4.2 OpenScape Access SLA.....	125
7.4.3 OpenScape Access SLO.....	126
7.4.4 OpenScape Access BRI.....	126
7.4.5 OpenScape Access TA.....	126
7.4.6 OpenScape Access SLC-M.....	127
7.4.7 Rear view of all OpenScape Access Modules.....	127
7.4.8 Dimensions and Weights.....	127
7.4.9 Environmental and Operating Conditions.....	128
7.4.10 Power Consumption.....	128
7.5 Installation, Configuration, Generation and Licensing.....	129
7.5.1 Generation for OpenScape Access Modules (Example).....	129
7.5.1.1 OpenScape Access Modules.....	129
7.5.1.2 Analog Ports in OpenScape EcoBranch.....	130
7.5.1.3 Reference Clock.....	130
8 Power FRUs.....	132
8.1 LUNA 2.....	132

Contents

8.1.1 LED Indications and Switches.....	132
8.1.2 Removing the LUNA 2.....	136
8.1.3 Replacing the LUNA 2.....	136
8.1.4 Verifying the LUNA 2.....	136
8.1.5 Power Failure Bridging for LUNA2.....	136
8.2 LUNA 3.....	136
8.2.1 LED Indications and Switches.....	137
8.2.2 Removing the LUNA 3.....	138
8.2.3 Replacing the LUNA 3.....	138
8.2.4 Verifying the LUNA 3.....	138
8.2.5 Power Failure Bridging for LUNA 3.....	138
8.3 UACD (Lineage Power) 19-Inch Installation.....	138
8.3.1 Overview.....	139
8.3.2 Technical parameters.....	141
8.4 UDCD (Lineage Power).....	142
9 Legacy Hardware.....	143
9.1 SHELF FRUs.....	143
9.1.1 L80XF Shelf.....	143
9.1.1.1 Removing the L80XF Backplane.....	144
9.1.1.2 Replacing the L80XF Backplane.....	145
9.1.1.3 Verifying the L80XF Shelf.....	145
9.1.2 LTUW Shelf.....	146
9.1.2.1 Connectors.....	146
9.1.2.2 Removing the LTUW Backplane.....	147
9.1.2.3 Replacing the LTUW Backplane.....	147
9.1.2.4 Verifying the LTUW Shelf.....	148
9.1.3 IPDA Architecture.....	148
9.1.3.1 Equipment.....	149
9.1.4 AP 3700-9 Shelf.....	149
9.1.4.1 Shelf Population (Front).....	150
9.1.4.2 Shelf Population (Back) with Patch Panels.....	151
9.1.4.3 Shelf Population (Back) without Patch Panels.....	151
9.1.4.4 AP 3700-9 Backplane Connections.....	152
9.1.5 Survivability Server.....	153
9.2 Boards.....	156
9.2.1 DIU2U.....	156
9.2.1.1 Functional Description.....	157
9.2.1.2 Hardware.....	157
9.2.1.3 LED Indications.....	159
9.2.1.4 Configuring the DIU2U Board.....	160
9.2.1.5 Removing the DIU2U Board.....	165
9.2.1.6 Replacing the DIU2U Board.....	166
9.2.1.7 Verifying the DIU2U Board.....	167
9.2.2 DIU-N2 / DIU-N4.....	167
9.2.2.1 LED indications.....	168
9.2.2.2 Board Variants.....	168
9.2.2.3 Board Functions.....	168
9.2.2.4 Copper interface.....	169
9.2.2.5 Connecting Variants to DIU-N2 Ports.....	169
9.2.2.6 SIPAC Connector Pin Assignments.....	170
9.2.2.7 Sub-D Connectors X21 and X22 Pin Assignments.....	171
9.2.2.8 Sub-D line interface connectors X23 and X24 Pin Assignments.....	171
9.2.2.9 Configuring the DIU-N2 Board Using AMOs.....	172
9.2.3 LTUCA.....	173
9.2.3.1 LEDs.....	174

9.2.3.2 Hardware Part Number.....	174
9.2.3.3 Use in Extended Shelves.....	174
9.2.3.4 Cable Types.....	174
9.2.3.5 LTUCA Hardware Concept (Application Scenarios).....	175
9.2.3.6 Power Supply.....	175
9.2.4 NCUI2+.....	175
9.2.4.1 System Diagram.....	176
9.2.4.2 Board Variants and Modules.....	176
9.2.4.3 LED Displays and Interfaces.....	177
9.2.4.4 Power Supply.....	178
9.2.4.5 Upgrade NCUI2 board.....	178
9.2.5 NCUI4.....	183
9.2.5.1 System Diagram.....	183
9.2.5.2 Board Variants and Modules.....	184
9.2.5.3 LED Displays and Interfaces.....	184
9.2.5.4 Power Supply.....	186
9.2.6 PBXXX - Peripheral Board XXX.....	186
9.2.6.1 Hardware Partnumber.....	186
9.2.6.2 Interfaces.....	186
9.2.6.3 Dip-switch.....	187
9.2.6.4 Recommendations.....	189
9.2.6.5 PNE/PBXXX Application.....	189
9.2.6.6 CDG/PBXXX Application.....	190
9.2.7 Ring Generator.....	190
9.2.7.1 LED Indications.....	191
9.2.7.2 Ringer Module Types.....	191
9.2.7.3 Ringer Settings.....	191
9.2.7.4 Jumper settings for Ring Voltages.....	192
9.2.7.5 Jumper Setting for AC Generator (only for S30810-Q6141-X).....	193
9.2.7.6 Removing the Ring Generator.....	193
9.2.7.7 Replacing the Ring Generator.....	194
9.2.7.8 Verifying the Ring Generator.....	194
9.2.8 SIU/SIUX2.....	194
9.2.9 SLC24 Subscriber Line CMI24.....	194
9.2.9.1 LED Indications.....	195
9.2.9.2 X200 Board Layout.....	195
9.2.9.3 Interfaces.....	195
9.2.9.4 Power Supply.....	197
9.2.9.5 Block Diagram.....	198
9.2.10 SLMA2.....	198
9.2.10.1 Module Variant.....	199
9.2.10.2 LED Indications.....	199
9.2.10.3 Interface to the Administration.....	199
9.2.10.4 Power Supply Interface.....	200
9.2.10.5 Battery Supply.....	200
9.2.10.6 Interfaces.....	201
9.2.10.7 Connector Pin Assignment.....	203
9.2.10.8 Removing SLM Boards.....	206
9.2.10.9 Replacing SLMA2 Board.....	207
9.2.10.10 Verifying the SLMA2 Board.....	207
9.2.11 SLMA3.....	208
9.2.11.1 Functional Description.....	208
9.2.11.2 LED Indications.....	209
9.2.11.3 Country Spread for SLMA3 and SLMA24 Utilization.....	210
9.2.11.4 SLMA24 (SLMA2) Properties/Restrictions Compared to SLMA3.....	215
9.2.11.5 Removing the SLMA3 Board.....	216

Contents

9.2.11.6 Replacing SLMA3 Board.....	217
9.2.11.7 Verifying the SLMA3 Board.....	218
9.2.11.8 MDF Assignments.....	218
9.2.12 SLMAC.....	219
9.2.12.1 Functional Description.....	219
9.2.12.2 LED Indications.....	222
9.2.12.3 Removing the SLMAC Board.....	223
9.2.12.4 Replacing SLMAC Board.....	223
9.2.12.5 Verifying the SLMAC Board.....	224
9.2.12.6 MDF Assignments.....	224
9.2.13 SLMAE.....	225
9.2.13.1 Functional description.....	225
9.2.13.2 LED Indications.....	227
9.2.13.3 Removing SLMAE Board.....	228
9.2.13.4 Replacing SLMAE Board.....	229
9.2.13.5 Verifying the SLMAE Board.....	230
9.2.13.6 MDF Assignments.....	230
9.2.14 SLMAR.....	237
9.2.14.1 Feature Overview.....	237
9.2.14.2 LED Indications.....	237
9.2.14.3 Subscriber Interface.....	238
9.2.14.4 Hardware Integrity.....	240
9.2.14.5 Backplane Pin Assignments.....	241
9.2.15 SLMO24.....	243
9.2.15.1 Board Variants.....	244
9.2.15.2 LED Indications.....	244
9.2.15.3 Removing the SLMO24 Board.....	245
9.2.15.4 Replacing the SLMO24 Board.....	246
9.2.15.5 Verifying the SLM024 Board.....	246
9.2.15.6 SLMO24 Board MDF Assignments, U.S.....	247
9.2.16 SLMOP.....	248
9.2.16.1 Basic configuration.....	248
9.2.16.2 Range of features.....	248
9.2.16.3 General operation.....	249
9.2.16.4 Board variants.....	249
9.2.16.5 Subscriber Line Module, UP0/E Interface.....	249
9.2.17 SLMQ.....	250
9.2.17.1 UK0-2B1Q Interfaces.....	251
9.2.17.2 SLMQ Board LED Indications.....	251
9.2.17.3 Removing the SLMQ Board.....	252
9.2.17.4 Replacing the SLMQ Board.....	252
9.2.17.5 Verifying the SLMQ Board.....	253
9.2.17.6 SLMQ MDF Assignments, U.S.....	253
9.2.18 SLMQ3.....	254
9.2.18.1 Functional Description.....	255
9.2.18.2 LED Indications.....	256
9.2.18.3 Removing the SLMQ3 Board.....	256
9.2.18.4 Replacing SLMQ3 Board.....	257
9.2.18.5 Verifying the SLMQ3 Board.....	257
9.2.18.6 MDF Assignments.....	258
9.2.19 STHC.....	259
9.2.19.1 Feature Characteristics.....	259
9.2.19.2 UP0E Interface.....	260
9.2.19.3 S0 Interface.....	260
9.2.19.4 Board Variants.....	261
9.2.20 STMA.....	261

9.2.20.1 Features.....	262
9.2.20.2 LED Indications and Connector.....	263
9.2.20.3 Removing the STMA Board.....	265
9.2.20.4 Replacing the STMA Board.....	266
9.2.20.5 Verifying the STMA Board.....	267
9.2.21 STMD.....	267
9.2.21.1 LED Indications.....	268
9.2.21.2 Board Variants.....	268
9.2.21.3 Board Functions.....	269
9.2.21.4 Configuring the STMD Board Using AMOs.....	269
9.2.21.5 PIN Assignments.....	269
9.2.22 STMD2.....	272
9.2.23 STMI4.....	273
9.2.23.1 System Diagram.....	273
9.2.23.2 Board Variants and Modules.....	274
9.2.23.3 LED Displays and Interfaces.....	274
9.2.23.4 Power Supply.....	276
9.2.24 TM2LP.....	276
9.2.24.1 Board Variants.....	277
9.2.24.2 Loadware Variants.....	277
9.2.24.3 Configuration Example for Switzerland.....	278
9.2.25 TM3WI/TM3WO.....	281
9.2.25.1 Board Variants.....	281
9.2.25.2 LED Indications.....	281
9.2.25.3 Functions and Features for GUS.....	292
9.2.25.4 Interfaces.....	293
9.2.25.5 Connector Pin Assignments.....	293
9.2.25.6 Line Signaling Flow Diagrams.....	296
9.2.25.7 First Party Release Control (MGTS).....	299
9.2.25.8 Calling Party Release Control (Unilateral LONIIS).....	301
9.2.25.9 Calling party release control (Unilateral MGTS).....	302
9.2.25.10 Signaling times for INLOC and OTLOC.....	302
9.2.26 TMBD.....	309
9.2.27 TMC16.....	311
9.2.27.1 LED Indications.....	312
9.2.27.2 Removing the TMC16 Board.....	313
9.2.27.3 Replacing the TMC16 Board.....	314
9.2.27.4 Verifying the TMC16 Board.....	314
9.2.27.5 MDF Assignments.....	314
9.2.28 TMCOW.....	315
9.2.28.1 Module Variants.....	316
9.2.28.2 LED Indications.....	317
9.2.28.3 DIP-FIX Switches.....	317
9.2.28.4 Call Charge Pulse Detection at 50 Hz.....	318
9.2.28.5 Loop Grounding.....	318
9.2.28.6 Loadware Variants.....	318
9.2.29 TMDID.....	321
9.2.29.1 LED Indications.....	322
9.2.29.2 Switches.....	322
9.2.29.3 Removing the TMDID Board.....	323
9.2.29.4 Replacing the TMDID Board.....	323
9.2.29.5 Verifying the TMDID Board.....	324
9.2.29.6 MDF Assignments.....	324
9.2.30 TMDID2.....	325
9.2.30.1 Front Panel.....	326
9.2.30.2 LED Statuses and Their Meanings.....	326

- 9.2.30.3 Cable and Connector Assignment.....327
- 9.2.30.4 Removing the TMDID2 Board..... 332
- 9.2.30.5 Replacing the TMDID2 Board.....333
- 9.2.30.6 Verifying the TMDID2 Board..... 334
- 9.2.31 TMDNH..... 334
 - 9.2.31.1 LED Indications..... 334
 - 9.2.31.2 Removing the TMDNH Board.....336
 - 9.2.31.3 Replacing the TMDNH Board..... 337
 - 9.2.31.4 Verifying the TMDNH Board..... 337
- 9.2.32 TMEM..... 337
 - 9.2.32.1 Board Variants.....338
 - 9.2.32.2 Carrier Frequency and Ear & Mouth Modes..... 338
 - 9.2.32.3 WTK 1 Mode.....338
 - 9.2.32.4 Configuring the TMEM Board on the Main PABX Circuit Using AMOs..... 339
 - 9.2.32.5 Configuring the TMEM Board on the Satellite PABX Using AMOs..... 339
 - 9.2.32.6 TMEW and TMEUS Board LED Indications..... 339
 - 9.2.32.7 Connectors and Switches..... 340
 - 9.2.32.8 Removing the TMEM Board..... 340
 - 9.2.32.9 Replacing the TMEM Board..... 341
 - 9.2.32.10 Verifying the TMEM Board.....341
 - 9.2.32.11 MDF Punch-Down Assignments, U.S..... 342
- 9.2.33 TMEW and TMEUS..... 342
 - 9.2.33.1 Functional Description..... 343
 - 9.2.33.2 LED Indications..... 343
 - 9.2.33.3 Connectors and Switches..... 344
 - 9.2.33.4 Removing the TMEW or TMEUS Board.....346
 - 9.2.33.5 Replacing the TMEW or TMEUS Board..... 347
 - 9.2.33.6 Verifying the TMEW or TMEUS Board..... 348
 - 9.2.33.7 MDF Assignments.....348
- 9.2.34 TMEW2..... 349
 - 9.2.34.1 Functions and Features for Target Countries..... 349
 - 9.2.34.2 Description of Interfaces..... 350
 - 9.2.34.3 LED Indications..... 350
 - 9.2.34.4 Configuring the Board..... 350
 - 9.2.34.5 Connector Pin Assignments..... 352
 - 9.2.34.6 Removing the TMEW2 Board.....354
 - 9.2.34.7 Replacing the TMEW2 Board..... 354
 - 9.2.34.8 Verifying the TMEW2 Board..... 355
- 9.2.35 TMLBL..... 355
 - 9.2.35.1 LED Indications and Push Buttons..... 356
 - 9.2.35.2 Loadware Variants..... 356
 - 9.2.35.3 Functions of the Board..... 357
 - 9.2.35.4 Configuring the TMLBL Board Using AMOs..... 361
 - 9.2.35.5 Adding Board Configuration Data..... 361
- 9.2.36 TMLR..... 362
 - 9.2.36.1 LED Indications..... 362
 - 9.2.36.2 DIP-FIX Switches..... 363
 - 9.2.36.3 Signal Exchange..... 363
- 9.2.37 TMLRB..... 364
 - 9.2.37.1 LED and Key Indications..... 364
 - 9.2.37.2 Board Variants..... 366
 - 9.2.37.3 Loadware Variants..... 366
- 9.2.38 TMOM2..... 367
 - 9.2.38.1 Board Functions..... 367
 - 9.2.38.2 Pin Assignments..... 371
- 9.2.39 TMSFP..... 372

9.2.39.1 Board Variants.....	372
9.2.39.2 LED and Key Indications.....	372
9.2.39.3 Loadware Variants.....	372
9.2.39.4 DIP-FIX Switches.....	373
9.2.40 VCM Voice Compression.....	375
9.2.40.1 Switching Boards and Circuits.....	377
9.2.40.2 Activating and Deactivating Voice Compression.....	377
9.2.40.3 Configuring the VCM Board Using AMOs.....	377
9.2.40.4 Configuring the Shelves.....	377
9.2.40.5 Compression, Outgoing.....	379
9.2.40.6 Decompression, Incoming.....	379
9.2.40.7 Transit Connections.....	380
9.2.40.8 Mixed Mode Operation, Voice and Data.....	381
9.2.40.9 Administering More Data Channels or More Voice Channels.....	382
9.3 Power FRUs.....	382
9.3.1 AC-Powered, Non-Redundant System (with L80XF Shelf).....	382
9.3.2 DC-Powered, Non-Redundant System (with L80XF Shelf).....	382
9.3.3 AC-Powered, Redundant System (with LTUW Shelf).....	383
9.3.4 DC-Powered, Redundant System (with LTUW Shelf).....	383
9.3.5 ACPCI/DCPCI.....	383
9.3.5.1 ACPCI/DCPCI Input Power Connectors.....	385
9.3.5.2 Hardware Variants.....	385
9.3.5.3 LED Indications.....	386
9.3.5.4 Removing the ACPCI/DCPCI.....	386
9.3.5.5 Replacing the ACPCI/DCPCI.....	386
9.3.5.6 Verifying the ACPCI/DCPCI.....	386
9.3.5.7 Input/Output Assignment.....	387
9.3.6 LPC80.....	387
9.3.6.1 LPC80 Power Connection.....	388
9.3.6.2 LPC80 Power Supply Unit, Technical Data.....	388
9.3.6.3 LPC80 LED Indications.....	391
9.3.6.4 LPC80 Connectors and Switches.....	392
9.3.6.5 Removing the LPC80.....	392
9.3.6.6 Replacing the LPC80.....	393
9.3.6.7 Verifying the LPC80.....	393
9.3.7 PSUP.....	393
9.3.7.1 PSUP LED Indications.....	393
9.3.7.2 Removing the PSUP.....	394
9.3.7.3 Replacing the PSUP.....	395
9.3.7.4 Verifying the PSUP.....	395
9.3.8 UACD.....	395
9.3.8.1 ACDPX.....	396
9.3.8.2 EBCCB.....	400
9.3.8.3 LPC.....	402
9.3.8.4 PDPX2.....	404
9.3.9 UACD (PSR930/PSR930E).....	408
9.3.10 UDCD (Zytron).....	408
9.3.10.1 ICBP.....	409
9.3.10.2 ODP.....	411
9.3.10.3 ZYT.....	414
9.4 Access Modules.....	417
9.4.1 OpenScope Access SLC.....	417
10 Software.....	418
11 OpenScope 4000.....	419

Contents

11.1 OpenScape 4000 in the Customer LAN.....	419
11.1.1 LAN Interfaces.....	419
11.1.2 Checking the IP Addresses Used.....	419
11.2 Simplex/Duplex.....	420
11.2.1 Feature Description.....	420
11.2.2 Simplex Operation.....	421
11.2.3 Duplex Operation.....	421
11.2.4 Separated Duplex Operation.....	424
11.2.5 Switch Over Scenarios for Duplex and Separated Duplex.....	426
11.2.6 Manual Switch Over.....	430
11.3 Supported Interfaces.....	430
11.4 Portlist.....	431
11.5 Hardware Architecture Table.....	431
11.5.1 Layout.....	431
11.5.2 Configuration Batch.....	432
12 OpenScape 4000 CSTA.....	433
13 OpenScape 4000 Assistant.....	434
13.1 Important Information.....	434
13.2 OpenScape 4000 Assistant Applications.....	434
13.3 User Accounts.....	438
13.4 Notification Mechanism and Usage Scenarios.....	438
13.4.1 The Notification Mechanism.....	438
13.4.1.1 Operation of the Notification Mechanism.....	439
13.4.1.2 AMO Commands Generated for Notifications.....	439
13.4.1.3 Possible Sources of AMO Notifications.....	440
13.4.2 Networks without OpenScape 4000 Manager.....	440
13.4.3 Networks with OpenScape 4000 Manager.....	442
Index.....	443

1 Hardware

2 Important Information

2.1 Environmental and Operating Conditions

Table 1: Environmental and operating conditions

Air temperature	0 °C to +40 °C
Relative humidity	5% - 85%

2.2 LAN with DC Voltage



CAUTION: The OpenScope 4000 system may not be operated in a LAN in which a DC voltage is overlaid on the data lines, since there are still switches that connect directly without checking the supply voltage first. Depending on the transformer at the LAN interface, voltages of up to 500 V can be induced. Such peak voltages usually lead to destruction of the physical LAN controller's logic.

2.3 Lightning Protection



CAUTION: The OpenScope 4000 PSU has adequate lightning protection at the 230-V port for up to 2 kV. Additional lightning protection is recommended upstream of the connecting line in high-risk areas. The lightning protection strip with part number C39334-Z7052-C32 offers added protection of up to 4 kV. The lightning protection strip is a mandatory requirement for Brazil.



CAUTION: Lightning protection on the boards: Analog and digital subscriber lines are protected on the boards using protection up to 2kV longitudinal and kV transverse voltage against high-energy overvoltage in in pulses from 10/700us and 1.2/50us which can be induced by a lightning strike. The protection is only effective if the systems are grounded correctly in accordance with the installation instructions.

Grounding: After grounding the OpenScope 4000 check the low-impedance grounding of the system via the ground wire of the power supply circuit as well as the low-impedance connection of the additional permanently connected protective grounding strip to the building potential equalizing bar.



CAUTION: External lightning protection: In cases where the line length exceeds 500m or when lines run outside the building, analog and digital station boards must be protected with external lightning protection. This lightning protection is designated as "additional primary protection".

It is installed either on the main distribution frame (MDF) or at the point where the line enters the building. A surge arrester (overvoltage protector) with a 230V nominal voltage is connected against ground by each wire to be protected. If this additional primary protection is not installed, lightning strikes above the voltage limits named above may destroy the boards. This may in turn lead to a failure of the entire system or to device overheating (fire risk).

3 OpenScape EcoServer

The OpenScape EcoServer (as successor of the OpenScape 4000 EcoServer) is the new system control unit of OpenScape 4000 (for V8 and V10). The 1,5 rack units sized 19-inch housing contains the complete control unit including the alarm interfaces and connectors for AP3x00 Access Points.

The order number for OpenScape EcoServer is S30122-K7760-X.



Figure 1: OpenScape EcoServer



CAUTION: In case of mounting in a cabinet the EcoServer may not weight on with other components/equipments. The mounting material is prepared for the EcoServer only and is not able to take on the weight of additional hardware.

This new system combines a main processor module, the RTM functionality and the connectivity functions of the MCM. To build up a the new redundant system it is possible to connect two of the new 19" based systems together using a special cross connection.

A new RTM is integrated in the EcoServer for connecting to the Access Points AP3xxx. Furthermore for the connectivity, currently provided by the MCM, and also for some of the interfaces of the new main processor board additional functionality and interfaces are integrated on the new RTM board. This new RTM is named "Rear Transition Module Extended", called RTMx.

Two redundant hot plug power supplies fulfills the requirements for dual AC or DC inlets and high availability. All fixed cabling is connected to the rear panel of the box.

Inside the EcoServer two redundant high availability fans are installed. These fans are highly reliable and must not be changed.

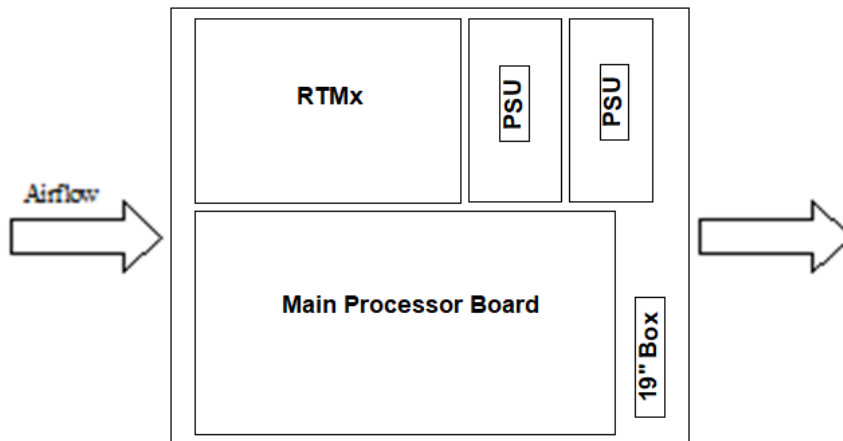

Figure 2: EcoServer: System Overview

3.1 External Interfaces

3.1.1 EcoServer (Front Panel)



Figure 3: EcoServer: Front Panel View

Following interfaces are available on the front panel:

- Softkey (power on/off)
- Power LED
- Two 2.5" SSD (Solid State Disk) trays with dedicated SSD power and activity LEDs

NOTICE: Only SSDs certified by Unify may be used.

NOTICE: Data is only retained on the SSD (without power supply connection) for a limited time. Make sure that the SSD backup is updated regularly (at least every 3 months).

- 1 USB slave port for management access
- 4 USB ports (2x USB 3.0, 2x USB 2.0)
- Display port connection for maintenance purposes
- Push button for status display
- Small display, used for status messages
- Run/Fail-LED for CC
- Run/Fail-LED for RTM

3.1.2 EcoServer (Rear Panel)



Figure 4: EcoServer: Rear Panel View

Following interfaces are available on the rear panel:

- Main Power Supply Connector (max. 2x)
- 8x1 Gbit LAN interfaces for external ports for OpenScope
- 1x1 Gbit LAN interface for management
- 1x ALUM interface (VGA connector)
- 1x ALIN interface (Sub-D 9)

- 15x RJ45 for HiPath High Speed connect
- 1x "Ext. Clock Box" interface (Sub-D 25)
- 1x CrossConnect interface
- CCA/CCB-Status LEDs
- One chassis connection for potential equalization between second EcoServer and Host- Shelves.

3.1.3 Interface, Display and LED descriptions (Front Panel)

Power Button (Soft Key)

Functionalities:

- System is off -> Pressing the button -> System will start
- System is running -> Pressing the button (short period of time) -> 10 seconds countdown will show on display. Press the button again to confirm the action -> System will shutdown (with OS support)
- System is running -> Pressing the Button (long period of time, min 4s) -> System will power down (without clean shutdown)

SSD Trays

Two SSD trays (hot pluggable) are accessible from the front of the system. Two LEDs for each tray will signal if a drive is inserted:.

- Green LED (Power)
- Orange LED (activity of drive)

USB Slave Interface

One USB slave port is accessible from the front panel. This will be used for maintenance purpose, only.

USB Host Interfaces

4 USB ports (2x USB 3.0 + 2x USB 2.0 hi-speed) are accessible from the front panel. The system is bootable from USB2 and USB3 devices.

Display Port

The Display Port is used to connect a monitor for maintenance purposes.

Status Display

A small OLED display is integrated to display status messages. After a period of time the display will be switched off to expand the lifetime of the display. A push button on the front panel will allow the reactivation of the display and it also possible to change the displayed page by pressing this button. In case of X86 CPU-reset the content will be cleared.

Status LEDs

Four system status LEDs are visible on the front panel:

- A RUN (green) and a FAIL (red) LED display the status of the CC of the system (controlled by the OpenScape µController).
- One additional RUN (green) and FAIL (red) LED display the status of the RTMx (controlled from the RTMx).

3.1.4 Interface, Display and LED descriptions (Rear Panel)

- Power Supply (max. 2x)

ALUM (trunk failure transfer) - Duplex Configuration

In contrast to the predecessor the EcoServer has two ALUM interfaces in a duplex configuration (each EcoServer has one interface).

However it is allowed to connect a cable only to one EcoServer ALIN interface.

The design is supporting always both interfaces, regardless which EcoServer is active or standby. The signals are connected parallel to both boxes over the CrossConnect cable. So it doesn't matter which interface will be used. The service technician might use one of the interfaces. Also if the EcoServer with the used ALUM-interface is powered off, the second box will serve the interface of the power-off EcoServer.

The following three signals are routed via this interface:

- ALUM (trunk failure transfer), max. 1A/30W
 - ALUM off: System is ok (ALUM contact is closed)
 - ALUM on: System had a problem, e.g. reload (ALUM contact is open)
- NAL (Not urgent Alarm)
- UAL (Urgent Alarm)

These signals are transmitted via relays to the connector (15-pin) from the rear side, which is connected in turn to the main distribution frame via the cable C39195-Z7612-A* (DSub connector, open end).

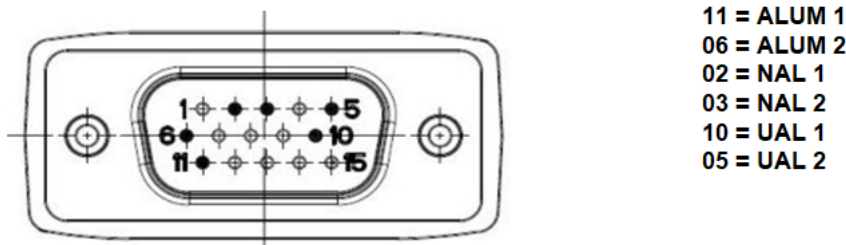

Figure 5: EcoServer: ALUM pin assignment

ALUM cable types:

Table 2: EcoServer: ALUM cable types

Part number	Type	Cable length
C3919-Z7612-A100	ASW cable to MDF	10m
C39195-Z7612-A200	ASW cable to MDF	20m
C39195-Z7612-A550	ASW cable to MDF	55m
C39195-Z7612-A950	ASW cable to MDF	90m
C39195-Z7613-A505	ASW cable to patch panel (release for IM)	5m

Part number	Type	Cable length
C39195-Z7614-A100	ASW cable to MDF	10m
C39195-Z7614-A150	ASW cable to MDF	15m

ALIN (alarm interface) - Duplex Configuration

In contrast to the predecessor, the EcoServer has two ALIN interfaces in a duplex configuration (each EcoServer has one interface).

It is allowed to connect a cable only to one EcoServer ALIN interface.

The design is supporting always both interfaces, regardless which EcoServer is active or standby. The signals are connected parallel to both boxes over the CrossConnect cable.

Table 3 shows the alarm signals that are routed via this interface (cable: S30122-X8011-X12):

Table 3: EcoServer: Alarm signals

Signal	Name
WRA	DC/AC converter fail
NGAR	Power supply failure redundancy
NGA	Power supply failure
PFNMI	Power supply interruption
BAEXF	BAEX board error
GND	Ground connection

The PIN assignment is described in Table 4 (V.24 9-pin SUB-D connector):

Table 4: EcoServer: ALIN PIN Assignment

Signal	Pin	Pin	Signal
WRA	1	2	PFNMI
NGA	3	4	NGAR
GND	5	6	BAEXF
nc	7	8	nc
*) ALIN_TST	9	10	FGND

*) Pin 9 is not connected in the cable.

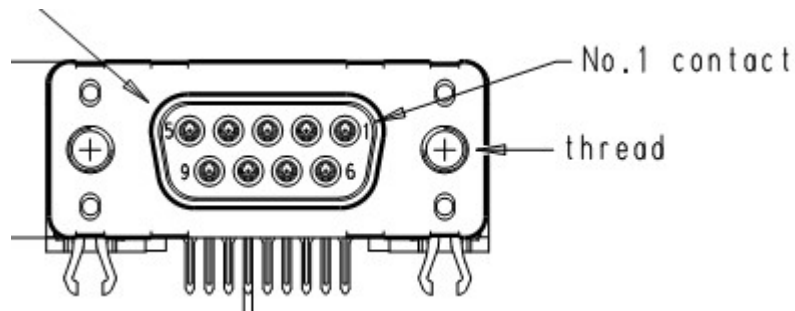

Figure 6: ALIN Connector

External Clock Box Interface

It is possible to connect Meinberg receiver for ISS synchronization (see Cordless Enterprise documentation) directly and AECB (ext. clock box) box. It is possible to connect these boxes at CC-A or CC-B optional.

3.2 Power Supply

Technical Data:

- AC-Version: Working Voltage = 90 VAC to 264 VAC, (Rated Voltage: 100 VAC to 240 VAC)
- DC-Version: DC-Input = -48V
- Hot pluggable
- Operating temperature: 0° - 40° external environmental temperature

3.3 Fan Control

The fan management unit works without the support of a running operating system. The redundant fans are controlled by an autonomous unit. The fan control unit adapts the speed of the fans according to the measured temperature to avoid critical temperatures for all installed devices in the system.

3.4 Replacement of Components

Following components are replaceable by service technician:

- [Replacing Power Supply](#)
- [Replacing SSD Tray](#)
- [Removing Empty Tray](#)
- [Replacing RTC \(Real Time Clock\) Battery](#)
- [Replacing defect server](#)



CAUTION: Only the components described here may be replaced. Opening of the housing cover is not permitted. If the housing seal is removed or broken, the guarantee for the device becomes null and void automatically and Unify will not give credit for returned goods, regardless of the reason why the device has been returned.

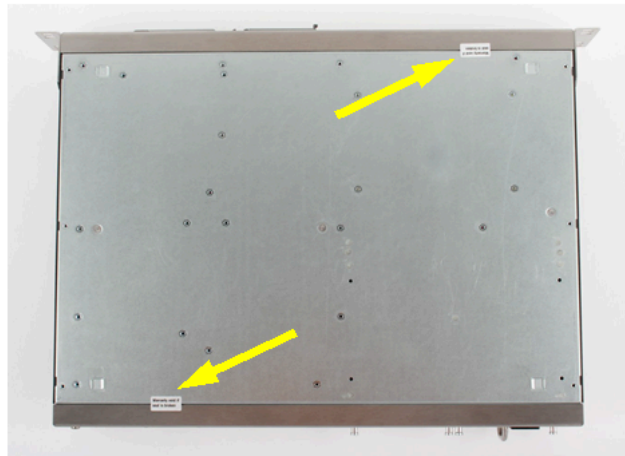

Figure 7: EcoServer: Warranty Seal

3.4.1 Replacing Power Supply

- 1) Loosen the two fixing screws (1) for the power supply on the rear of the EcoServer.
- 2) Remove the power supply by the handle (2).
- 3) Insert the new power supply.
- 4) Screw in the two fixing screws tightly again (1).

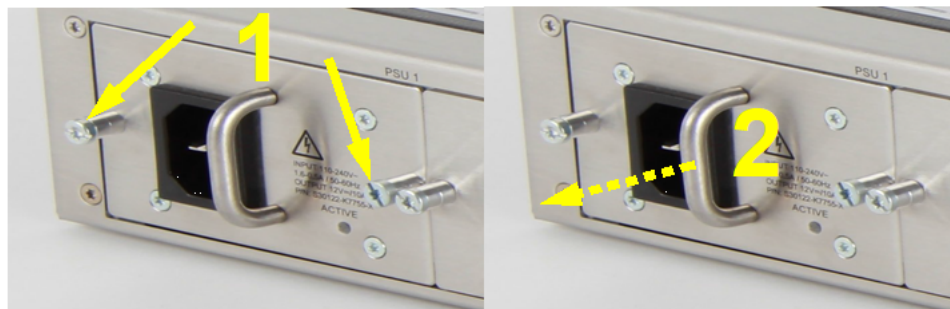

Figure 8: EcoServer: Replacing AC Power Supply

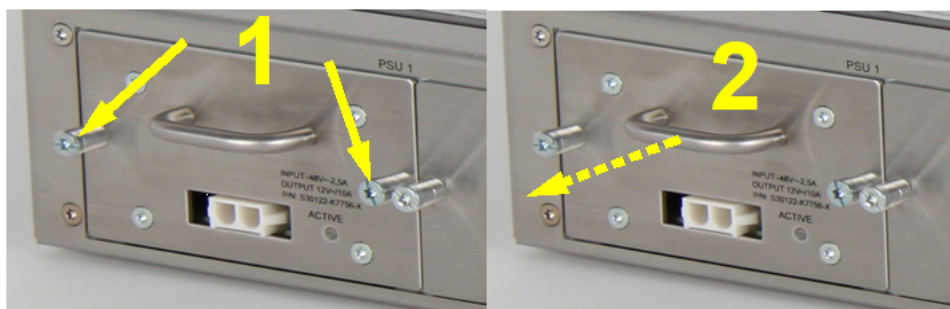

Figure 9: EcoServer: Replacing DC Power Supply

3.4.2 Replacing SSD Tray

- 1) Press the green locking lever (1) to the left (the lockable cover on the SSD tray opens).
- 2) Pull out the SSD tray evenly on both sides (2).
- 3) Now insert the new SSD tray into the designated opening on the front panel.



Figure 10: EcoServer: Replacing SSD Tray

3.4.3 Removing Empty Tray

- 1) Remove the empty tray from the EcoServer by sliding the locking lever (1) on the right-hand side of the tray to the left and pulling out the tray evenly using two fingers.



Figure 11: EcoServer: Empty Tray

3.4.4 Replacing RTC (Real Time Clock) Battery

- 1) Remove the SSD tray (1), see also "[Replacing SSD Tray](#)".
- 2) Press the lock on the battery holder gently upwards (2) and carefully remove the battery holder (3).
- 3) Gently press the battery out of the holder (4).

- 4) Insert the new battery by pressing it gently until it engages in the battery holder.

CAUTION: Make sure that the polarity is correct when replacing the RTC battery. The correct polarity +/- is indicated on both sides of the battery holder (5).

- 5) Once you have inserted the battery, push the battery holder back into the designated opening until the lock on the battery holder engages (2).
- 6) Now push the SSD tray into the front panel again.

Under normal operating conditions, the lifespan of the RTC battery is typically between a minimum of 8 years to 10++ years. In power-down mode, the battery guarantees the RTC parameters of the EcoServer for up to 7 years.

The battery may be changed while the EcoServer is powered on.

To prevent system downtime during power-on swap, a functioning SoftRAID to second SSD is required. First SSD can be removed from RAID via Portal GUI, then it can be physically removed to allow access to the battery. You can confirm via OLED that you are removing the correct SSD.

NOTICE: While the battery is removed, the appropriate HISTA message F6504 might be generated.

The Unify Order number for Battery Type CR2032 or BR2032 is V39113-Z7000-A3.

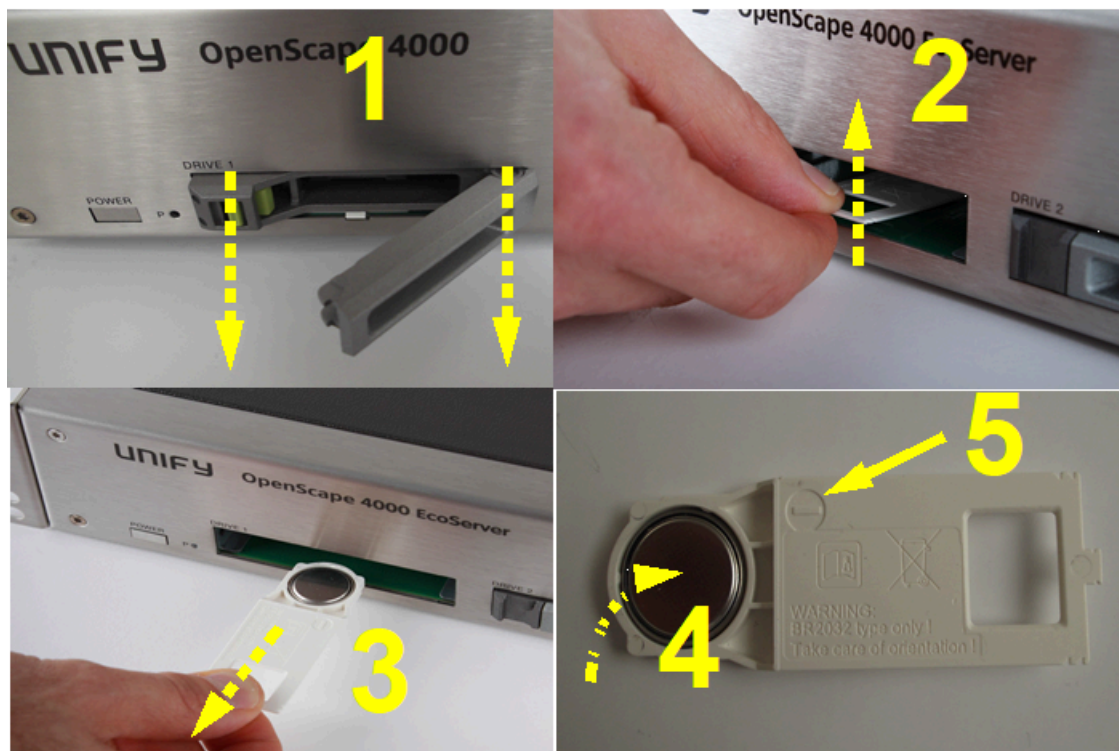

Figure 12: EcoServer: Replacing RTC Battery

3.4.5 Replacing defect server



CAUTION: The cross-connect cable (1) must not be plugged out of an active server when the system is running. The EcoServer contains a function that detects the existence of the cross-connect cable, even if the other end of the cable is open.



Figure 13: EcoServer: Duplex configuration with cross-connect cable (1)

- 1) Switch off the defective server using the Power button.
- 2) Remove the power cable.
- 3) Remove the cross-connect cable on the defective server only (do not remove the cross-connect cable from the active server as this would trigger a restart of the active server).
- 4) Replace the EcoServer.
- 5) Connect the cross-connect cable, which is still plugged into the active server, to the second EcoServer.
- 6) Connect the power cable to the second EcoServer and switch on the power supply.



CAUTION: Cross-connect cable itself cannot be replaced without telephony downtime.

4 OpenScape EcoBranch

The OpenScape EcoBranch is the solution for small to mid-size branches connected to a central OpenScape 4000 system. As such it succeeds the former OpenScape 4000 Branch and the older OpenScape Access 500a/i. All OpenScape Access modules can be connected.

Four analog ports are already integrated.

It is a 19" rack mountable server and 1,5 Rack Units high.

The order number for OpenScape EcoBranch is S30122-K7761-X.



Figure 14: OpenScape EcoBranch

OpenScape EcoBranch provides the possibility to run as a small OpenScape 4000 in Simplex mode.

OpenScape EcoBranch offers redundancy options for power supply (AC/AC; DC/DC and also AC/DC). A second storage medium (SSD) can be optional used for Data redundancy. The LAN interface is also designed redundantly as well as the cooling fans.

Due to faster storage medium (SSD) the installation is quicker.

For more information please refer to the related service documentation:

- OpenScape 4000, Volume 4: IP Solutions > OpenScape 4000 SoftGate
- OpenScape 4000, Volume 4: IP Solutions > IP Distributed Architecture (IPDA)



CAUTION: Opening of the housing cover of the box is not permitted. If the housing seal is removed or broken, the guarantee for the device becomes null and void automatically and Unify will not give credit for returned goods, regardless of the reason why the device has been returned.

4.1 External Interfaces

4.1.1 OpenScape EcoBranch (Front Panel)



Figure 15: OpenScape 4000 Branch/ OpenScape EcoBranch Front Panel View

Following interfaces (left to right) are available on the front panel:

- Power button
- Power LED
- 2x Slot for 2,5" SSD
- USB-B port for service access
- 2x USB 2.0 host
- 2x USB 3.0 host
- Display Port
- Status Display
- Status LEDs (RUN/FAIL)

NOTICE: Only SSDs certified by Unify may be used.

NOTICE: Data is only retained on the SSD (without power supply connection) for a limited time. Make sure that the SSD backup is updated regularly (at least every 3 months).

4.1.2 OpenScape EcoBranch (Rear Panel)

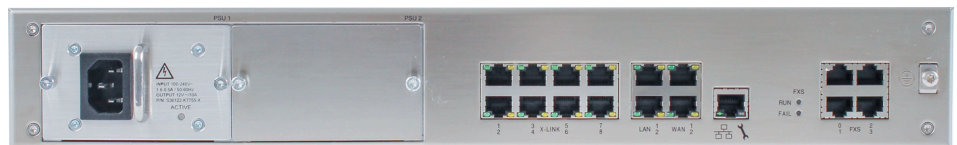

Figure 16: OpenScape EcoBranch: Rear Panel View

Following interfaces are available on the rear panel:

- 2x PSU (AC and/or DC)
- 8x X-Link LAN interface
- 2x LAN 1 GbE
- 2x WAN 1 GbE
- 1x 1 GbE (Management port)
- 2x run/fail LEDs
- 4x FXS
- 1x earth bolt

Table 5: Ethernet port assignment for OpenScape 4000 Branch

LAN Interface Tag on the back of the 4K Branch	ETH Device assigned in the Linux Platform	Remarks
LAN1	ETH0	same as A500 LAN ETH
WAN1	ETH1	same as A500 WAN ETH
XLINK1	ETH2	same as A500 XLINK ETH

LAN Interface Tag on the back of the 4K Branch	ETH Device assigned in the Linux Platform	Remarks
LAN2	ETH3	new/n.a on A500
WAN2	ETH4	new/n.a on A500

4.1.3 Interface, Display and LED descriptions (Front Panel)

Power Button (Soft Key)

Functionalities:

- System is off -> Pressing the button -> System will start
- System is running -> Pressing the button (short period of time) -> 10 seconds countdown will show on display. Press the button again to confirm the action -> System will shutdown (with OS support)
- System is running -> Pressing the Button (long period of time, min 4s) -> System will power down (without clean shutdown)

USB Slave Interface

One USB slave port is accessible from the front panel. This will be used for maintenance purpose, only.

USB Host Interfaces

4 USB ports (2x USB 3.0 + 2x USB 2.0 hi-speed) are accessible from the front panel. The system is bootable from USB2 and USB3 devices.

Display Port

The Display Port is used to connect a monitor for maintenance purposes.

Status Display

A small OLED display is integrated to display status messages. After a period of time the display will be switched off to expand the lifetime of the display. A push button on the front panel will allow the reactivation of the display and it also possible to change the displayed page by pressing this button. In case of X86 CPU-reset the content will be cleared.

Status LEDs

Four system status LEDs are visible on the front panel:

- A RUN (green) and a FAIL (red) LED display the status of the CC of the system (controlled by the OpenScape µController).

4.2 Power Supply

Technical Data:

- AC-Version: Working Voltage = 90 VAC to 264 VAC, (Rated Voltage: 100 VAC to 240 VAC)
- DC-Version: DC-Input = -48V

- Hot pluggable
- Operating temperature: 0° - 40° external environmental temperature

4.3 Grounding

Each OpenScape Access/Branch system must be connected with an external, permanently protective earthing conductor (PE).

Use separate ground wires to provide protective grounding for the OpenScape communication systems.

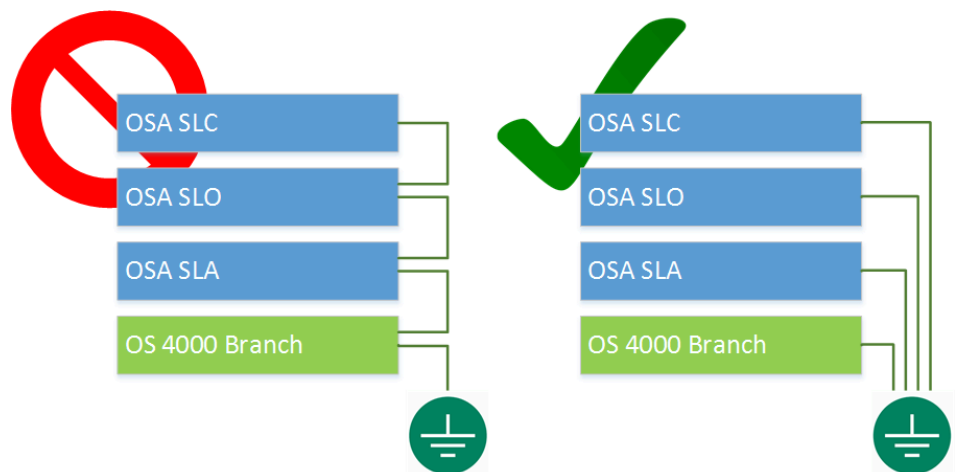

Figure 17: OpenScape 4000 Branch/OpenScape EcoBranch grounding concept

Before you start up the system and connect the phones and phone lines, connect the communication system with a permanent earthing conductor.

Make sure that the ground wire laid is protected and strain-relieved.

A protective ground wire with a minimum cross section of 12 AWG/2.5 mm² and a ring terminal

- The 19-inch rack is grounded by a separate ground conductor (green/yellow).
- The 19-inch rack is equipped with an equipotential bonding strip at which the communication system can be separately grounded.



Figure 18: Protective earth conductor (PE)

4.4 Fan Control

The fan management unit works without the support of a running operating system. The redundant fans are controlled by an autonomous unit. The fan control unit adapts the speed of the fans according to the measured temperature to avoid critical temperatures for all installed devices in the system.

4.5 OpenScape EcoBranch modules

- SLA module - 24 ports for the connection of analog subscribers (e.g. fax).
- SLO module - 24 UP0E for the connection of digital devices (e.g. OpenStage TDM).
- PRI module - 2 ports for the connection of a maximum of two S2 PSTN (PRI).
- BRI module - 8 ports for the connection of eight S0 PSTN or S0 subscribers.
- SLC module - 24 UP0E for the connection of DECT subscribers respectively the connection of the base station BS4 (OpenScape Cordless E V7).

NOTICE: Several modules of the same type can be connected. In addition to the number of available slots the restriction to 256 timeslots must be considered.

- TA module - exists in 3 different variants.

NOTICE: Redundancy for OSA module X-Link ports A & B is supported with OpenScape Access and OpenScape 4000 Branch/OpenScape EcoBranch, but will reduce the number of OSA modules which can be connected.

NOTICE: For more information, please refer to chapter [OpenScape Access Modules](#) on page 122.

4.6 Compatible Products

- Devices of the OpenStage telephone family.
- IP phones via OpenScape 4000 SoftGate application.
- Connection of analog devices (e.g. fax).
- All devices supported by the SLMO board will also be supported at the SLO module.

5 SHELF FRUs

This chapter describes the individual shelves and the procedures for removing, replacing and verifying them in a OpenScape 4000 system.

5.1 AP 3700-13 Shelf

Part number: S30805-G5413-X

The AP 3700-13 is a peripheral shelf with an LTUCA-control board that can be installed as a standalone system or in a 19" cabinet system. The AP 3700-13 can be populated with up to 13 peripheral modules.

The AP 3700-13 is also used in HiPath 3000, where it is called "H3800EB".

5.1.1 Shelf Population (Front)

Figure 21 shows the front view of AP 3700-13

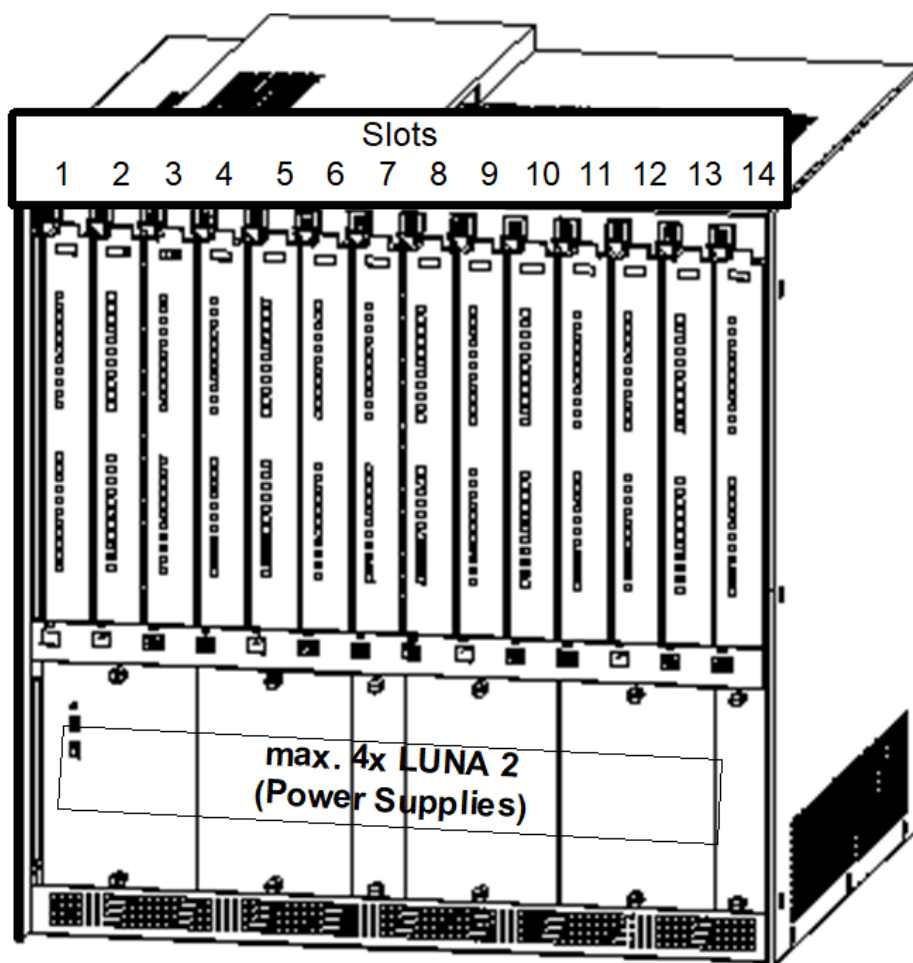

Figure 19: AP 3700-13 Front View

- Slot 1 -6: Peripheral modules

- Slot 7: Central control board LTUCA (AP3700-13)/not populated in H3800BB
- Slot 8- 14: Peripheral modules
- Up to four power supply units LUNA 2/ LUNA3

5.1.2 Shelf Population (Back) with Patch Panels

Figure 22 shows the back view of AP 3700-13 populated with patch panels

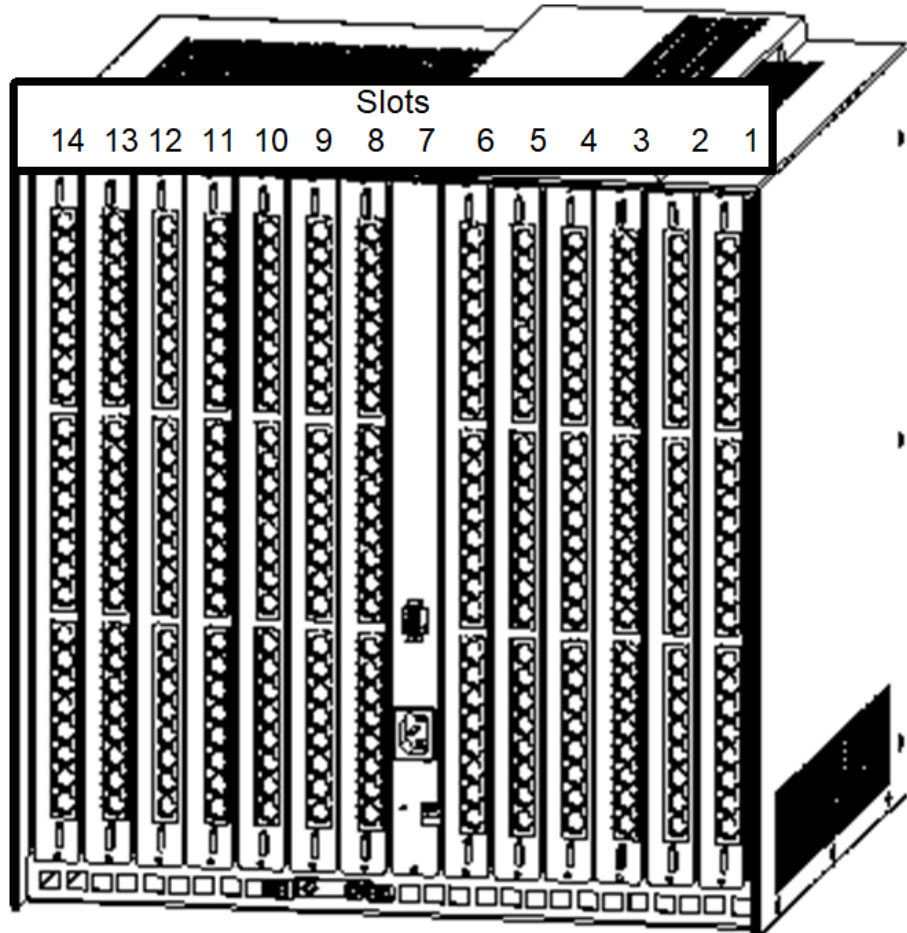

Figure 20: AP 3700-13 (Back View) with Patch Panels

- Slot 14 - 8: Patch panels (8, 20 and 24-port RJ-45 connector/CHAMP plug)
- Slot 7: Power supply connection board (DC at the top/AC at the bottom)
- Slot 6 -1: Patch panels (8, 20 and 24-port RJ-45 connector/CHAMP plug)
- Cable clip for earth connection

5.1.3 Shelf Population (Back) without Patch Panels

Figure 23 shows the back view of AP 3700-13 without patch panels

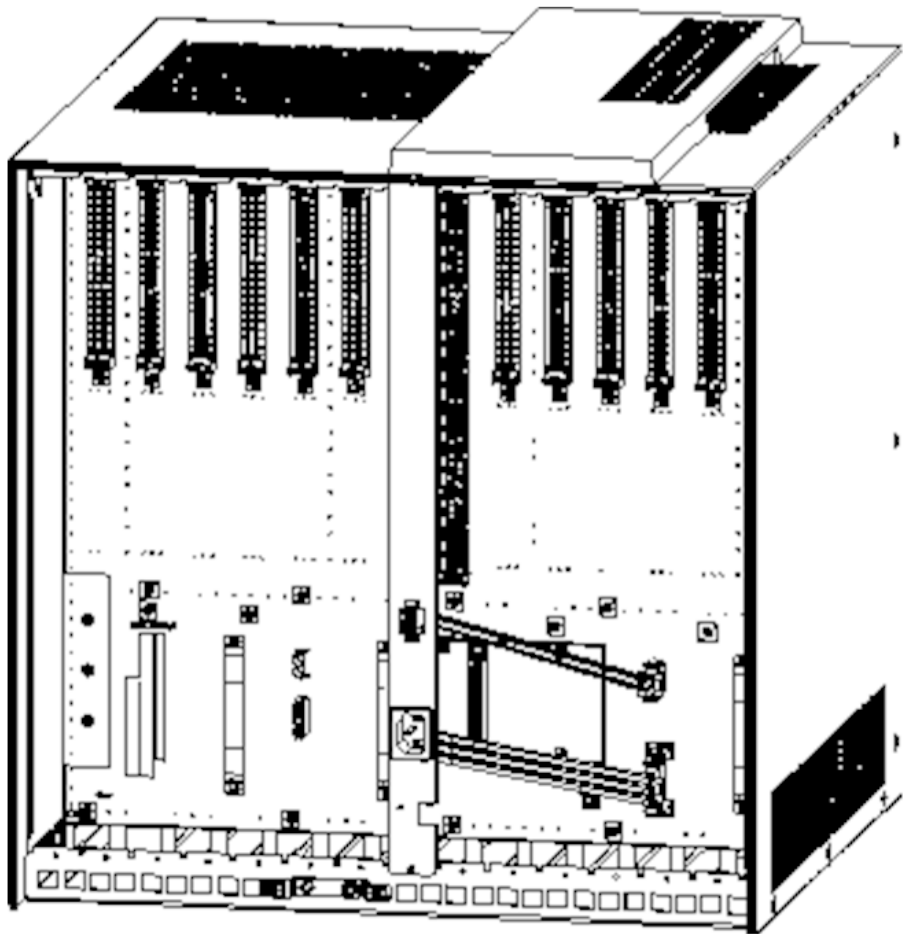

Figure 21: AP 3700-13 (Back View) without Patch Panels

- SIVAPAC connector on the backplane for cable connection to external patch panels or to a mains distribution frame (MDF)
- Power supply connection board (DC at the top/AC at the bottom)
- Cable clip for earth connection

5.1.4 AP 3700-13 Backplane Connections

Figure 24 shows the AP 3700-13 backplane connections

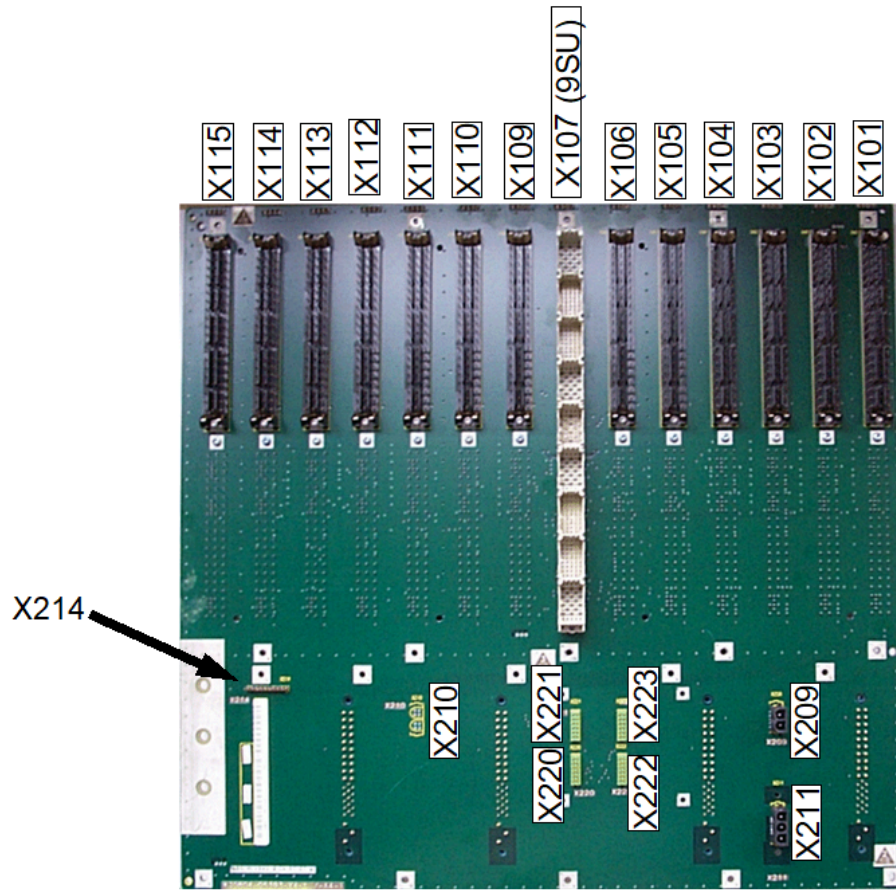

Figure 22: AP 3700-13 Backplane Connections

- Connector X101 - X106: SIVAPAC connector for peripheral connections
- Connector X107 (9SU): SIPAC connector for external signalling (e.g. reference clock)
- Connector X109 - X115: SIVAPAC connector for peripheral connections
- Connector X209/X210: DC connection
- Connector X211: AC connection
- Connector X214: 10-pin plug (RG module)
- Connector X220-223: 14-pin plug (4x DBSAP connection)

6 Boards

A list containing all released boards can be found on the OpenScape 4000 Product Homepage under the Intranet or via Partner Portal ("Documents -> Presales").

6.1 DIUT2

This section describes the functions and features of the Digital Interface Unit Trunk 2 (DIUT2) board. It also provides procedures for removing, replacing, and verifying this board.

6.1.1 Functional Description

This board unifies the two different cards DIUN2(Q2196) and DIU2U (Q2216) with one technology family on unique PCB. Additionally, two different LW variants will be supported:

- LW for E1 (ISDN & CAS)
- LW for T1 (BOS & MOS/CVN)

As its predecessors DIU2U and DIUN2 board, the DIUT2 can access either the four standard PCM highways of a LTU shelf or the new additional four highways of the extended (Wideband) LTU shelf.

IMPORTANT: The Optical interface at the backplane connectors are not supported by the DIUT2 board, because the optical adapter APCFL is phased-out. The Optical Interface must be used only in the front connectors.

E1 Loadware:

The E1 loadware of DIUT2 is based on the existing DIUN2/ISDN and DIUN2/CAS LWs with no functional changes in E1 applications.

T1 Loadware:

The T1 loadware of DIUT2 board is derived from the current loadware of DIU2U board and all features already implemented in the current loadware are kept active in the new one, except by the TSSI (Time Slot Sequence Integrity).

The DIUT2 provides two T1 spans with MOS/CVN signaling and only one span with BOS signaling.

6.1.2 Systems Supported

The DIUT2 can replace the DIU2U/DIUN2 modules in SWU equal or greater than HiPath 4000 V3.0. An upgrade of existing systems is not possible.

6.1.3 Hardware

The DIUT2 board has two interfaces (see [Figure 25](#)) that connect to adapter cables (see [Section 6.1.3.5, "Cables and Adapters"](#)) and two LEDs which indicates the status of board.

The order number for DIUT2 is S30810-Q2226-X200.

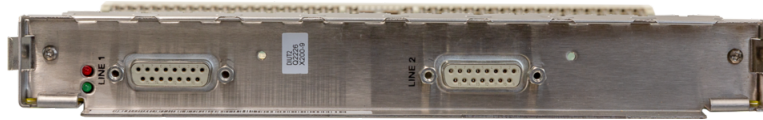

Figure 23: DIUT2 Front panel

6.1.3.1 Hardware Variants

S30810-Q2226-X200

6.1.3.2 LED statuses and their meanings

Table 6: DIUT2 - LED Statuses

Red LED	Green LED	Status	Action
Off	Off	Board not receiving power or not plugged in correctly. Board is out of order.	Check plug contact on board.
On	Off	Board is receiving power and board test is in progress. Board is defective if status remains unchanged (board test unsuccessful).	Replace the board.
		Loadware loading not successfully completed. Board is faulty.	Replace the board.
		Error detected on board. Board is deactivated (not applicable to errors detected by test loops).	Check whether the board was deactivated. If not, replace board.
Flashing	Off	Loadware is being loaded.	
Off	On	Board test completed successfully. Board is OK (idle state).	
Off	Flashing	At least one subscriber line circuit is activated.	

6.1.3.3 Power supply

The DIUT2 is powered by a +5V ($\pm 5\%$) from the backplane. Other required voltage are generated from onboard regulators, namely +1.5V and +3.3V.

6.1.3.4 DIUT2 Interfaces

Connectors on Backplane/Front Panel

Table 7: External Connections

Connector Identifier	Function	Connector Type	Location
X1 to X9	System interface	SIPAC	Backplane
X10	E1/T1 link 0	DB15 female	Front Panel
X11	E1/T1 link 1	DB15 female	Front Panel

DB15 Connector pin assignment X10/X11

Table 8: DB15 Connector pin assignment

Pin	Signal	Direction	Description
1	TTIP	Output	Transmitter Port (balanced pair with TRING)
2	NC		Not Connected
3	NC		Not Connected
4	LWLO_F	Output	Transmit Optical interface Data (+5V logic)
5	GND		Ground
6/7	SCAN_IN	Input	Adapter check (+5V logic active high). Pin 6 and 7 are tied together.
8	RTIP	Input	Receiver Port (balanced pair with RRING)
9	TRING	Output	Transmitter Port (balanced pair with TTIP)
10	5V	Output	5V Supply
11	LWLI_F	Input	Receiver optical interface Data (+5V logic)
12	GND		Ground
13	NC		Not Connected

Pin	Signal	Direction	Description
14	5V	Output	5V Supply
15	RRING	Input	Receiver Port (balanced pair with RTIP)

SIPAC Connector pin assignment X1 to X9

Table 9: SIPAC Connector pin assignment

Signal Name	Connector Pin	Signal Description	Direction
+ 5V	X1-22, X4-30, X5-30, X9-28	Power Supply + 5 V DC	Input
U_VOR	X5-16, X5-26, X5-36, X5-18, X5-28, X5-38	Power Supply + 5 V DC for hot plug	Input
GND	X1-24, X2-26, X3-26, X4-28, X6-22, X7-24, X8-24, X9-26 X5-12, X5-22, X5-32, X5-14, X5-24, X5-34	Ground return for the + 5 V DC	Input / Output
GND	X5-23	Ground return for the hot plug	Not connected
- 48V	X6-04	-48V power supply	Not connected
BGx_0A, BGx_0B	X1-02, X1-26 X1-06, X1-08 X1-10, X2-02 X2-04, X2-06 X2-08, X2-10 X3-02, X3-04 X3-06, X3-08 X3-10, X4-02	Trunks 0 to 7 AB pair	Not connected
HO0 ... HO3	X8-22, X7-30, X8-44, X8-42	Old PCM Highways (2.048 Mbps)	Input
HI0 ... HI3	X9-24, X9-02, X9-44, X9-42	Old PCM Highways (2.048 Mbps)	Output
WHO0 ... WHO3	X6-32, X6-33, X6-34, X6-35	New PCM Highways (2.048 Mbps)	Input

Signal Name	Connector Pin	Signal Description	Direction
WHI0 ... WHI3	X7-31, X7-32, X7-33, X7-34	New PCM Highways (2.048 Mbps)	Output
HDI	X9-06	HDLC Highway	Input
HDO	X8-04	HDLC Highway	Output
PRS	X7-26	System Reset	Input
BA0 ... BA6	X7-06, X7-28, X8-26 X8-28, X9-04, X8-06, X8-2	Shelf Address Identifier	Input
FMB	X9-22	Clock synchronizing signal	Input
CKA	X8-08	System clock (2.048 MHz)	Input
CLS	X8-10	Clock select (CLS=GND --> CKA=2,048 MHz) The CLS-pin is expected to be connected to ground in the Backplane.	Input
RCLK	X7-02	Reference clock	Output
RAC	X7-04	Reference clock enable Active low to enable RCLK Tri-state to disable CLK	Output tri- state
LWLOOP	X4-04	Self-test result output	Not connected
TOUT	X6-48	Self-test result output	Not connected
TCK	X7-44	Boundary scan: test clock	Not connected
TMS	X7-46	Boundary scan: test mode select	Not connected
TDI	X7-48	Boundary scan: test data input	Not connected
TDO	X7-50	Boundary scan: test data output	Not connected

6.1.3.5 Cables and Adapters

DIUT2 use the same cables and adapters as the DIU2U and DIUN2 modules.

Table 10: DIUT2 Cables and adapters

Application	Part number	Type
T1	C39195-A7269-B625	100Ω Unshielded twisted pair
E1	S30267-Z167-A100	120Ω Shielded twisted pair 10m
E1	S30267-Z80-A*	75Ω Coaxial cable
E1	S30267-Z83-A*	75Ω Coaxial cable for UK

S2 adapter DBM15 to RJ 45

Wiring of a DBM15 plug with a RJ 45 jack.

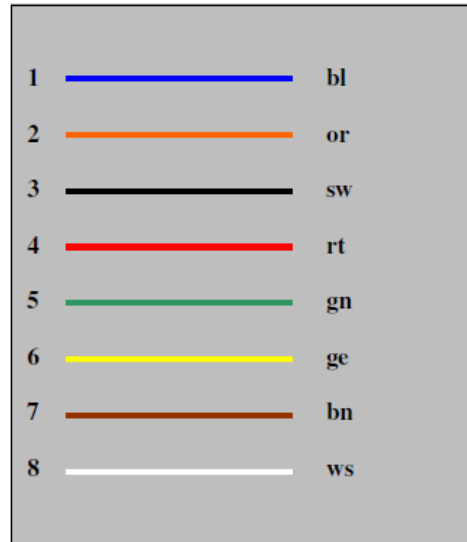
RJ 45:**DB15M:**

(View from backside [Cable])

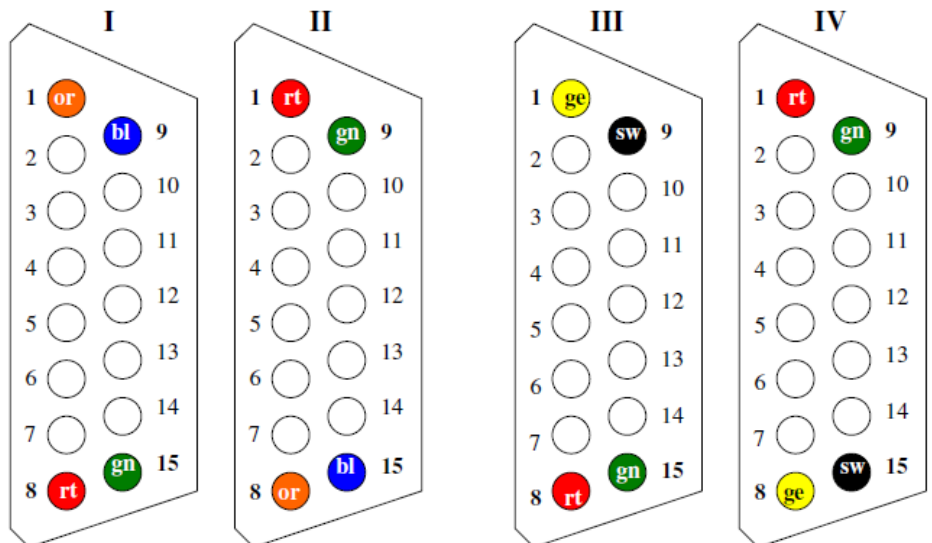
S2 via direct LAN-Cable (1-2 / 4-5)**S2 via ISDN Patch-Pannel (3-6 / 4-5)****Figure 24: S2 adapter DBM15 to RJ 45**

Usage Scenarios:

- Type I for direct cable connection to client (e.g. MMCS, OpenScape Office)
- Type II for direct cable connection to network (e.g. NTBA)
- Type III for connections to clients via ISDN patch panel
- Type IV for connection to NTBA via ISDN patch panel (ISDN patch panel uses pin 3-6/4-5 instead of 1-2/4-5 in separated cables)

6.1.4 Board substitution

It is possible to substitute the boards from DIUN2 to DIUT2 or DIU2U to DIUT2.

Examples:

DIUN2 ISDN ---> DIUT2 E1 ISDN

```
CHA-BCSU:TYPE=PARTNO,LTG=1,LTU=18,SLOT=7,PARTNO1=Q2196-X, PARTNO2=Q2226-X200,FCTID1=1,FCTID2=1;
```

DIUT2 E1 ISDN ---> DIUN2 ISDN

```
CHA-BCSU:TYPE=PARTNO,LTG=1,LTU=18,SLOT=7,PARTNO1=Q2226-X200, PARTNO2=Q2196-X,FCTID1=1,FCTID2=1;
```

DIUN2 CAS ---> DIUT2 E1 CAS

```
CHA-BCSU:TYPE=PARTNO,LTG=1,LTU=18,SLOT=7,PARTNO1=Q2196-X, PARTNO2=Q2226-X200,FCTID1=1,FCTID2=1;
```

DIUT2 E1 CAS ---> DIUN2 CAS

```
CHA-BCSU:TYPE=PARTNO,LTG=1,LTU=18,SLOT=7,PARTNO1=Q2226-X200, PARTNO2=Q2196-X,FCTID1=2,FCTID2=2;
```

DIU2U BOS ---> DIUT2 T1 BOS

```
CHA-BCSU:TYPE=PARTNO,LTG=1,LTU=17,SLOT=43,PARTNO1=Q2216-X, PARTNO2=Q2226-X200,FCTID1=5,FCTID2=3;
```

DIUT2 T1 BOS ---> DIU2U BOS

```
CHA-BCSU:TYPE=PARTNO,LTG=1,LTU=17,SLOT=43,PARTNO1=Q2226-X200, PARTNO2=Q2216-X,FCTID1=3,FCTID2=5;
```

DIU2U MOS ---> DIUT2 T1 MOS

```
CHA-BCSU:TYPE=PARTNO,LTG=1,LTU=17,SLOT=43,PARTNO1=Q2216-X, PARTNO2=Q2226-X200,FCTID1=6,FCTID2=4;
```

DIUT2 T1 MOS ---> DIU2U MOS

```
CHA-BCSU:TYPE=PARTNO,LTG=1,LTU=17,SLOT=43,PARTNO1=Q2226-X200, PARTNO2=Q2216-X,FCTID1=4,FCTID2=6;
```

To programming trunk parameters, the same programming used to DIUN2 (E1 CAS or E1 ISDN) and DIU2U (T1 BOS or T1 MOS) boards can be used without changes in DIUT2 board.

IMPORTANT: Please see that the parameters PARTNO1 and FCTID1 are not required, but if included, then the SSW can check if the information/replacement is correct.

6.1.5 Configuring DIUT2 board in the AMO BCSU

IMPORTANT: See that there is a strange characters (j) at the E1 ISDN and T1 BOS lines

```
E1 ISDN - PARTNO=Q2226-X200, FCTID = 1  
ADD-BCSU:MTYPE=DIU,LTG=1,LTU=1,SLOT=97,PARTNO="Q2226-X200",LWVAR=0,FCTID=1,HWYBDL=A,ALARMNO=0;
```

E1 CAS - PARTNO=Q2226-X200, FCTID = 2

ADD-BCSU:MTYPE=DIU, LTG=1, LTU=1, SLOT=12, PARTNO="Q2226-X200", LWVAR=0, LWPAR1=1, FIDX1=1, LWPAR2=1, FIDX2=1, FCTID=2, HWYBDL=A,

T1 BOS - PARTNO=Q2226-X200, FCTID = 3

ADD-BCSU:MTYPE=TMD, LTG=1, LTU=1, SLOT=67, PARTNO="Q2226-X200", FCTID=3, LWVAR=0, LWPAR=4, FIDX=1, HWYBDL=A, ALARMNO=0;

BOS: It is possible to use only the first link.

T1 MOS - PARTNO=Q2226-X200, FCTID = 4

ADD-BCSU:MTYPE=TMD, LTG=1, LTU=1, SLOT=103, PARTNO="Q2226-X200", FCTID=4, LWVAR=0, HWYBDL=A, ALARMNO=0;

6.1.6 Removing the DIUT2 Board

IMPORTANT: This procedure removes all the channels on this trunk board from service.

NOTICE: Static Sensitive Devices! Observe all precautions in for electrostatic discharge.

Remove the DIUT2 board as follows:

IMPORTANT: For ISDN applications, first deactivate the B channels, and then deactivate the D channel.

1) Deactivate all channels as follows:

- a) Type DEA-DSSU and press Enter.
- b) Type the following values, then press Enter.

Field	Value
OFFTYPE	DC
TYPE	PEN
PEN1	<PEN1>
PEN2	<PEN2>

IMPORTANT: PEN1 is the PEN of the first channel and PEN2 is the PEN of the last channel on the board.

2) Deactivate the board as follows:

- a) Type DEA-BSSU and press Enter.
- b) Type the following values, then press Enter.

Field	Value
OFFTYPE	DC
LTG	<1 - 32>
LTU	<1 - 8>
SLOT	<1 - 151>
REFOFF	<blank>

The board is deactivated when the red LED is lit and the green LED is off.

- 3) Before removing the board, ensure that the red board status LED is lit, remove the board.

If the red board status LED does not light within 30 seconds, repeat steps 2.a and 2.b. If the red board status LED still does not light within 30 seconds, remove the board.

6.1.7 Replacing the DIUT2 Board

Replace the DIUT2 board as follows:

- 1) Slide the board into the appropriate slot until it seats firmly into the backplane connector.
- 2) Activate the board as follows:
 - a) Type ACT-BSSU and press Enter.
 - b) Type the following values, then press Enter.

Field	Value
ONTYPE	AUL
LTG	<1 - 32>
LTU	<1 - 8>
SLOT	<1 - 151>

IMPORTANT: For ISDN applications, first activate the D channel, and then activate the B channels.

- 3) Activate the channels as follows:
 - a) Type ACT-DSSU and press Enter.
 - b) Type the following values, then press Enter.

Field	Value
ONTYPE	AUL
TYPE	PEN
PEN1	<PEN1>
PEN2	<PEN2>

IMPORTANT: PEN1 is the PEN of the first channel and PEN2 is the PEN of the last channel on the board.

6.1.8 Verifying the DIUT2 Board

To verify the operation of the DIUT2 board, confirm that the green LED turns on.

6.2 DIUT3

This section describes the functions and features of the Digital Interface Unit Trunk 3 (DIUT3) board. It also provides procedures for removing, replacing, and verifying this board.

6.2.1 Functional Description

The DIUT3 module (S30810-Q2238-X200) is the successor module of the DIUT2 (S30810-Q2226-X200). DIUT3 can be used together with DIUT2 module in the same system.

This board unify provides two E1 interfaces on unique PCB. Additionally, two different LW variants will be supported:

- LW for E1 (ISDN & CAS)
- LW for T1 (BOS & MOS/CVN)

NOTICE: Regarding the two E1 interfaces the DIUT3 module is functional compatible with DIUT2 with the following constraints:

- System software V10R1.42 or higher is required for operation
 - Cables with RJ45 connector socket instead of 15-pin Sub-D are required
 - Connection via optical interface (AMOM module) is not supported
-

E1 Loadware:

The E1 loadware of DIUT3 is based on the existing DIUT2/ISDN and DIUT2/CAS LWs with no functional changes in E1 applications.

T1 Loadware:

The T1 loadware of DIUT3 board is derived from the current loadware of DIUT2 board and all features already implemented in the current loadware are kept active in the new one.

The DIUT3 provides two T1 spans with MOS/CVN signaling and only one span with BOS signaling.

6.2.2 Systems Supported

The DIUT3 can replace the DIUT2/DIU2U/DIUN2 modules on systems with software version equal or greater than V10_R1.42.

6.2.3 Hardware

The DIUT3 front panel provides 2x service LEDs. Each RJ45 interface is also equipped with status LED indicate the operating states of the boards.

The order number of the DIUT3 is S30810-Q2238-X200 with the ability to connect two E1/T1 interfaces each. It is possible to use cables and adapters to connect (see [Section 6.2.3.5, "Cables and Adapters"](#)).

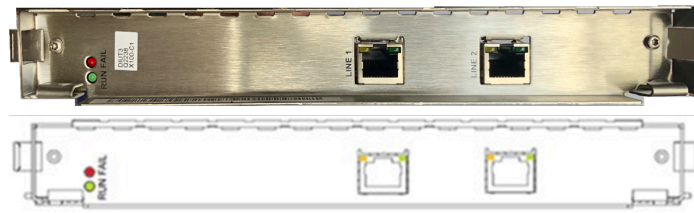
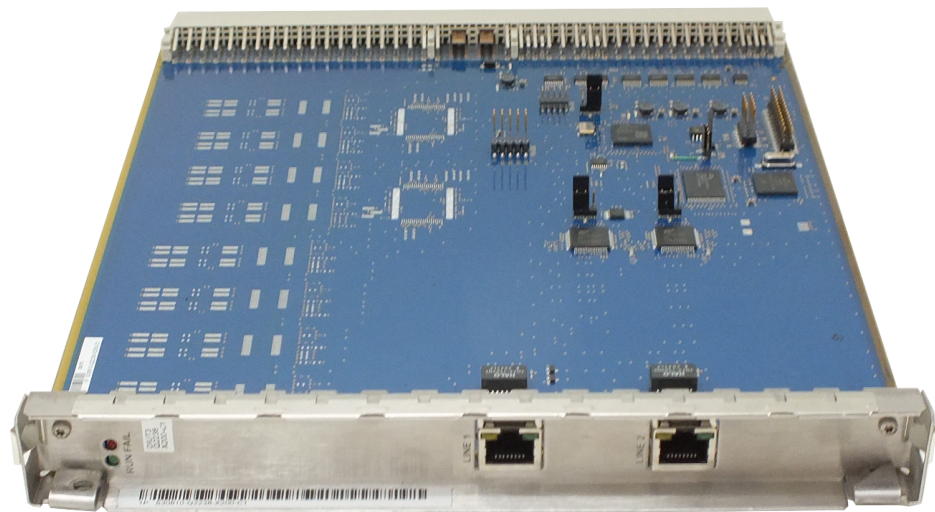

Figure 25: DIUT3 Front panel

6.2.3.1 Hardware Variants

S30810-Q2238-X200



6.2.3.2 LED status and their meanings

Table 11: DIUT3 - LED Status of the module

Red LED	Green LED	Status	Action
Off	Off	Board not receiving power or not plugged in correctly. Board is out of order.	Check plug contact on board.
On	Off	Board is receiving power and board test is in progress. Board is defective if status remains unchanged (board test unsuccessful).	Replace the board.
		Loadware loading not successfully completed. Board is faulty.	Replace the board.

Red LED	Green LED	Status	Action
		Error detected on board. Board is deactivated (not applicable to errors detected by test loops).	Check whether the board was deactivated. If not, replace board.
Flashing	Off	Loadware is being loaded.	-
Off	On	Board test completed successfully. Board is OK (idle state).	-
Off	Flashing	At least one subscriber line circuit is activated.	-

Table 12: DIUT3 - Interface LED Status

Yellow LED	Green LED	Meaning
Off	Off	No signal
On	Off	Layer 1 problem
On	On	Layer 1 up
Off	On	Layer 2 up

6.2.3.3 Power supply

The DIUT3 is powered by a +5V ($\pm 5\%$) from the backplane. Other required voltage are generated from onboard regulators, namely +1.5V +1.8V +1.0V and +3.3V.

6.2.3.4 DIUT3 Interfaces

Connectors on Front Panel

Table 13: External Connections

Connector Identifier	Function	Connector Type	Location
LINE 1	E1/T1 link 0	RJ45 jack	Front Panel
LINE 2	E1/T1 link 1	RJ45 jack	Front Panel

RJ45 Pin assignment

The front panel includes two RJ45 jacks with the following pin assignments. Pinout and orientation shielded 8-position modular plug at signal interfaces.

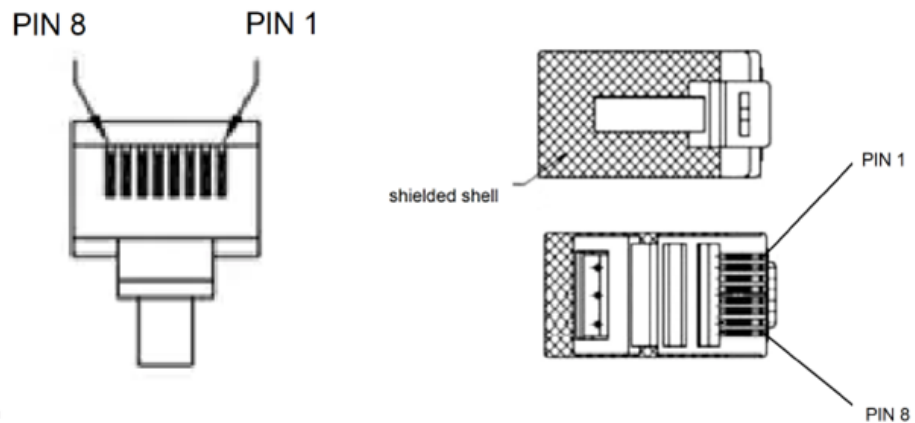

Figure 26: Pinout and orientation shielded 8-position modular plug

Table 14: Pin assignments of the RJ45 jack for direct connection to PSTN via 1:1 patch cable according to T568B

Pin	Description DIUT3 side	Direction DIUT3 side	Color code DIUT3 side	Direction PSTN side	Color code PSTN side
1	Receive Ring	Input	white/orange	Output	white/orange
2	Receive Tip	Input	orange	Output	orange
3	NC		white/green		white/green
4	Transmit Ring	Output	blue	Input	blue
5	Transmit Tip	Output	white/blue	Input	white/blue
6	NC		green		green
7	NC		white/brown		white/brown
8	NC		brown		brown

SIPAC Connector pin assignment X1 to X9

Table 15: Pin assignments of the RJ45 jack for direct connection to another DIUT3 or PBX-router via crossover cable according to T568B

Pin	Description DIUT3 side	Direction DIUT3 side	Color code DIUT3 side	Direction PSTN side	Color code PSTN side
1	Receive Ring	Input	white/orange	Output	blue
2	Receive Tip	Input	orange	Output	white/blue
3	NC		white/green		white/green
4	Transmit Ring	Output	blue	Input	white/orange

Pin	Description DIUT3 side	Direction DIUT3 side	Color code DIUT3 side	Direction PSTN side	Color code PSTN side
5	Transmit Tip	Output	white/blue	Input	orange
6	NC		green		green
7	NC		white/brown		white/ brown
8	NC		brown		brown

IMPORTANT: NC “not connected” pins, which are not internally connected to the module, so they can remain unconnected. The recommended color coding, according T568B standard, because contributes to better signal integrity (crosstalk phenomenon) and mechanical results.

However, a color code according T568A standard for patch cable/ crossover cables can also be used.

Table 16: SIPAC Connector pin assignment

Signal Name	Connector Pin	Signal Description	Direction
+ 5V	X1-22, X4-30, X5-30, X9-28	Power Supply + 5 V DC	Input
U_VOR	X5-16, X5-26, X5-36, X5-18, X5-28, X5-38	Power Supply + 5 V DC for hot plug	Input
GND	X1-24, X2-26, X3-26, X4-28, X6-22, X7-24, X8-24, X9-26 X5-12, X5-22, X5-32, X5-14, X5-24, X5-34	Ground return for the + 5 V DC	Input / Output
HO0 ... HO3	X8-22, X7-30, X8-44, X8-42	Old PCM Highways (2.048 Mbps)	Input
HI0 ... HI3	X9-24, X9-02, X9-44, X9-42	Old PCM Highways (2.048 Mbps)	Output
WHO0 ... WHO3	X6-32, X6-33, X6-34, X6-35	New PCM Highways (2.048 Mbps)	Input
WHI0 ... WHI3	X7-31, X7-32, X7-33, X7-34	New PCM Highways (2.048 Mbps)	Output
HDI	X9-06	HDLC Highway	Input

Boards

Signal Name	Connector Pin	Signal Description	Direction
HDO	X8-04	HDLC Highway	Output
PRS	X7-26	System Reset	Input
BA0 ... BA6	X7-06, X7-28, X8-26 X8-28, X9-04, X8-06, X8-2	Shelf Address Identifier	Input
FMB	X9-22	Clock synchronizing signal	Input
CKA	X8-08	System clock (2.048 MHz)	Input
CLS	X8-10	Clock select (CLS=GND --> CKA=2,048 MHz) The CLS-pin is expected to be connected to ground in the Backplane.	Input
RCLK	X7-02	Reference clock	Output
RAC	X7-04	Reference clock enable Active low to enable RCLK Tristate to disable CLK	Output tristate
LWLOOP	X4-04	Self-test result output	Not connected
TOUT	X6-48	Self-test result output	Not connected
TCK	X7-44	Boundary scan: test clock	Not connected
TMS	X7-46	Boundary scan: test mode select	Not connected
TDI	X7-48	Boundary scan: test data input	Not connected
TDO	X7-50	Boundary scan: test data output	Not connected

6.2.3.5 Cables and Adapters

DIUT3 use the same cables and adapters as the OSA-PRI modules.

For a direct connection to Central Office (CO), shielded CAT5 or CAT6 SFTP LAN cable with 1:1 pinout must be used. The minimum specifications are:

- LAN cable CAT5e, S/FTP, 4 pairs, 28 AWG
- LAN cable CAT6, S/FTP, 4 pairs, 26 AWG
- LAN cable CAT6A, F/UTP, 4 pairs, 26 AWG
- 2m, 4m and 6 meters cables are available to request from the Unify warehouse according to the part number described in [Table 17: Internal part number for Unify request](#) on page 51.

Table 17: Internal part number for Unify request

Application	Part number	Type
E1	LAN cable CAT6 C39195-Z7227-A20	120Ω Shielded twisted pair (2 meters)
E1	LAN cable CAT6 C39195-Z7227-A40	120Ω Shielded twisted pair (4 meters)
E1	LAN cable CAT6 C39195-Z7227-A60	120Ω Shielded twisted pair (6 meters)

The connection between 2 systems is supported on the DIUT3 module. CORNET/QSIG configuration is required and the cable cross-connection must be according to the pinout shown in table [Table 15: Pin assignments of the RJ45 jack for direct connection to another DIUT3 or PBX-router via crossover cable according to T568B](#) on page 48.

The connection via RF cables is also supported. It is recommended to use RF coaxial cables with minimum specification RF75 0.30/1.80 Cu/PE. An external impedance converter (balun) is required for impedance matching between unbalanced (75 ohms) and balanced (120 ohms) cables. Both commodities can be purchased at a local market.

6.2.4 Board substitution

It is possible to substitute the boards from DIUN2/DIU2U/DIUT2 to DIUT3.

Examples:

DIUT2 E1 ISDN ---> DIUT3 E1 ISDN

```
CHA-BCSU:TYPE=PARTNO,LTG=1,LTU=18,SLOT=7,PARTNO1=Q2226-X200,PARTNO2=Q2238-X200,FCTID1=1,FCTID2=1;
```

DIUT3 E1 ISDN ---> DIUT2 E1 ISDN

```
CHA-BCSU:TYPE=PARTNO,LTG=1,LTU=18,SLOT=7,PARTNO1=Q2238-X200,PARTNO2=Q2226-X200,FCTID1=1,FCTID2=1;
```

DIUT2 E1 CAS ---> DIUT3 E1 CAS

```
CHA-BCSU:TYPE=PARTNO,LTG=1,LTU=18,SLOT=7,PARTNO1=Q2226-X200,PARTNO2=Q2238-X200,FCTID1=2,FCTID2=2;
```

DIUT3 E1 CAS ---> DIUT2 E1 CAS

```
CHA-BCSU:TYPE=PARTNO,LTG=1,LTU=18,SLOT=7,PARTNO1=Q2238-X200,PARTNO2=Q2226-X200,FCTID1=2,FCTID2=2;
```

DIUT2 T1 BOS ---> DIUT3 T1 BOS

CHA-BCSU:TYPE=PARTNO,LTG=1,LTU=17,SLOT=43,PARTNO1=Q2226-X200,PARTNO2=Q2238-X200,FCTID1=3,FCTID2=3;

DIUT3 T1 BOS ---> DIUT2 T1 BOS

CHA-BCSU:TYPE=PARTNO,LTG=1,LTU=17,SLOT=43,PARTNO1=Q2238-X200,PARTNO2=Q2226-X200,FCTID1=3,FCTID2=3;

DIUT2 T1 MOS ---> DIUT3 T1 MOS

CHA-BCSU:TYPE=PARTNO,LTG=1,LTU=17,SLOT=43,PARTNO1=Q2226-X200,PARTNO2=Q2238-X200,FCTID1=4,FCTID2=4;

DIUT3 T1 MOS ---> DIUT2 T1 MOS

CHA-BCSU:TYPE=PARTNO,LTG=1,LTU=17,SLOT=43,PARTNO1=Q2238-X200,PARTNO2=Q2226-X200,FCTID1=4,FCTID2=4;

To programming trunk parameters, the same programming used to DIUN2/ DIUT2 (E1 ISDN, E1 CAS, T1 BOS and T1 MOS) boards can be used without changes in DIUT3 board.

6.2.5 Configuring DIUT3 board in the AMO BCSU

E1 ISDN - PARTNO=Q2238-X200, FCTID = 1

ADD-BCSU:MTYPE=DIU,LTG=1,LTU=1,SLOT=97,PARTNO="Q2238-X200",LWVAR=0,FCTID=1,HWYBDL=A,ALARMNO=0;

E1 CAS - PARTNO=Q2238-X200, FCTID = 2

ADD-BCSU:MTYPE=DIU,LTG=1,LTU=1,SLOT=12,PARTNO="Q2238-X200",LWVAR=0,LWPAR1=1,FIDX1=1,LWPAR2=1,FIDX2=1,FCTID=2,HWYBDL=A,ALARMNO=0;

T1 BOS - PARTNO=Q2238-X200, FCTID = 3

ADD-BCSU:MTYPE=TMD,LTG=1,LTU=1,SLOT=67,PARTNO="Q2238-X200",FCTID=3,LWVAR=0,LWPAR=4,FIDX=1,HWYBDL=A,ALARMNO=0;

BOS: It is possible to use only the first link.

T1 MOS - PARTNO=Q2238-X200, FCTID = 4

ADD-BCSU:MTYPE=TMD,LTG=1,LTU=1,SLOT=103,PARTNO="Q2238-X200",FCTID=4,LWVAR=0,HWYBDL=A,ALARMNO=0;

6.2.6 Removing the DIUT3 Board

IMPORTANT: This procedure removes all the channels on this trunk board from service.

NOTICE: Static Sensitive Devices! Observe all precautions in for electrostatic discharge.

Remove the DIUT3 board as follows:

IMPORTANT: For ISDN applications, first deactivate the B channels, and then deactivate the D channel.

1) Deactivate all channels as follows:

- a) Type DEA-DSSU and press Enter.
- b) Type the following values, then press Enter.

Field	Value
OFFTYPE	DC
TYPE	PEN
PEN1	<PEN1>
PEN2	<PEN2>

IMPORTANT: PEN1 is the PEN of the first channel and PEN2 is the PEN of the last channel on the board.

2) Deactivate the board as follows:

- a) Type DEA-BSSU and press Enter.
- b) Type the following values, then press Enter.

Field	Value
OFFTYPE	DC
LTG	<1 - 32>
LTU	<1 - 8>
SLOT	<1 - 151>
REFOFF	<blank>

The board is deactivated when the red LED is lit and the green LED is off.

3) Before removing the board, ensure that the red board status LED is lit, remove the board.

If the red board status LED does not light within 30 seconds, repeat steps 2.a and 2.b. If the red board status LED still does not light within 30 seconds, remove the board.

6.2.7 Replacing the DIUT3 Board

Replace the DIUT3 board as follows:

- 1) Slide the board into the appropriate slot until it seats firmly into the backplane connector.
- 2) Activate the board as follows:
 - a) Type ACT-BSSU and press Enter.
 - b) Type the following values, then press Enter.

Field	Value
ONTYPE	AUL
LTG	<1 - 32>
LTU	<1 - 8>
SLOT	<1 - 151>

IMPORTANT: For ISDN applications, first activate the D channel, and then activate the B channels.

3) Activate the channels as follows:

- a) Type ACT-DSSU and press Enter.
- b) Type the following values, then press Enter.

Field	Value
ONTYPE	AUL TYPE
PEN1	<PEN1>
PEN2	<PEN2>

IMPORTANT: PEN1 is the PEN of the first channel and PEN2 is the PEN of the last channel on the board.

6.2.8 Verifying the DIUT3 Board

To verify the operation of the DIUT3 board, confirm that the green LED turns on.

6.3 LTUCR

IMPORTANT: Due to discontinuing some components for LTUCA, the LTUCR is a LTUCA replacement. The LTUCR has exactly the same functionality as the LTUCA. Because of having a new HW-ID and part number, the LTUCR will be recognized completely as a new board. LTUCR is supported only in HiPath 4000 V6 and OpenScape 4000 V7 and newer versions.

The LTUCR (Line Trunk Unit Control Replacement) board (see [Figure 28](#)) is the interface between central and peripheral parts of the system. The LTUCR selects the signals from the active control unit and distributes them to the appropriate boards in the LTU shelf (LTU shelf is a general expression for all types of peripheral shelf. It can be one of the compact or extended compact shelves). The LTUCR also receives signals from the peripheral boards and transmits them to the common control.

Existing LTU cables are the same as already used for LTUCA board (RJ45 CAT5). The signals are routed in a multiplexed data flow. This multiplex functionality is supported on the common control side of the RTM board and on the peripheral side of the LTUCR board.

Two (HSC = High Speed Connect) interfaces are provided on the LTUCR for CCA and CCB. Two RJ45 connector sockets are installed for this on the front of the LTUCR board.

The LTUCR board can be integrated in the following system architectures:

- OpenScape 4000 (AP3300 flexpack)
- OpenScape 4000 (AP3700 19" architecture)

IMPORTANT: The LTUCR does not replace the LTUCX or LTUCE in existing systems. These boards are still used because the LTUCR is not compatible with old processor boards.

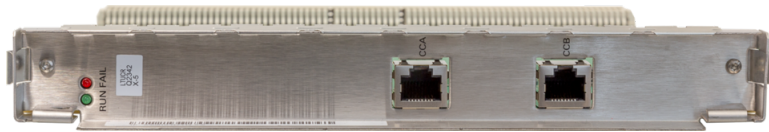

Figure 27: LTUCR front view

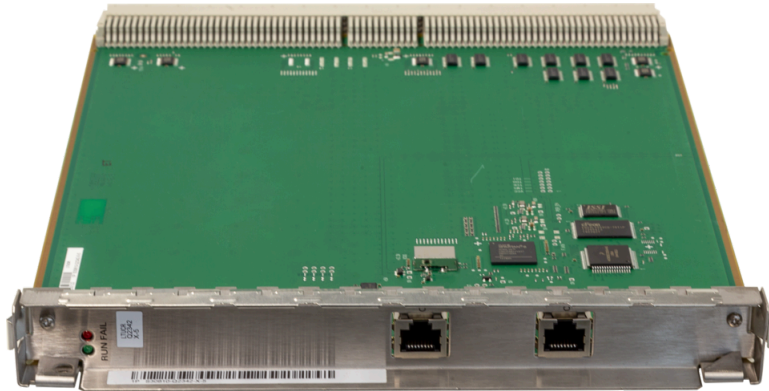

Figure 28: LTUCR board

6.3.1 LEDs

The front side of the board features a green LED (RUN) and a red LED (FAIL) that indicate board status.

6.3.2 Part Number

S30810-Q2342-X*

6.3.3 Use in Extended Shelves

- LTUW: S30804-B5388-A/X / S30804-B5367-X
- L80XF: S30804-B5389-A/X
- 19" Expansion Box ▪ old color (SAPP-EB): S30805-G5413-X
- 19" Expansion Box ▪ new color (SAPP-EB): S30777-U779-X1

Cabinets:

- S30805-G5408-X/A Cabinet UP
- S30805-G5404-X/A Cabinet UPR

...A=USA,X =IM

6.3.4 Cable Types

The following CAT 5 RJ45 cable types are available for connecting the LTU shelf:

Table 18: LTUCR cable types

C39195-Z7211-A20	, 2 m	twisted cable, 10BT (RJ45)
C39195-Z7211-A50	, 5 m	twisted cable, 10BT (RJ45)
C39195-Z7211-A100	, 10 m	twisted cable, 10BT (RJ45)

6.3.5 Hardware Concept (Application Scenarios)

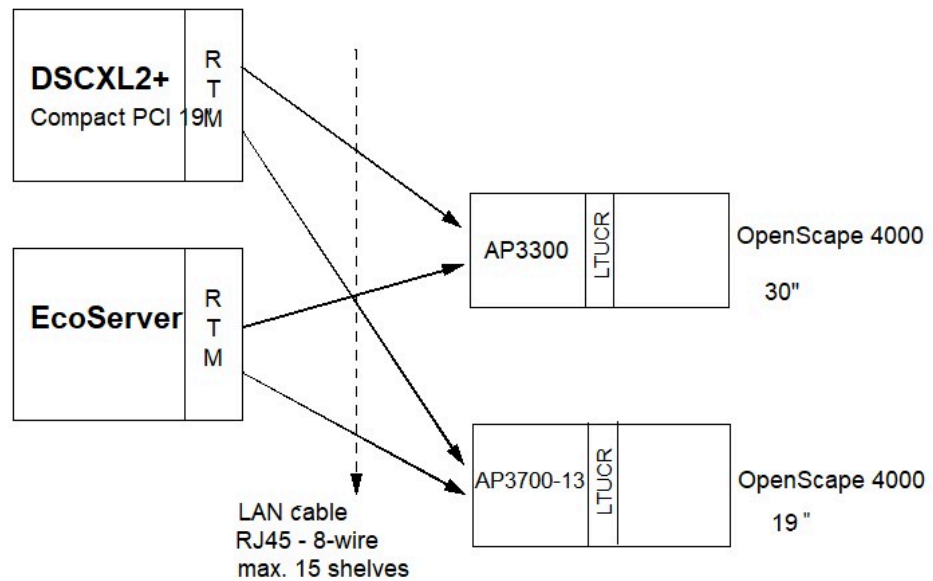

Figure 29: LTUCR diagram for OpenScape 4000 (Example)

6.3.6 Power Supply

The LTUCR board receives a direct current of 5 V over the backplane. The individual voltages required (1.2 V/3.3 V) are generated by the DC/DC converter on the board.

6.3.7 Loadware

The loadware for the LTUCR board also contains the firmware for the FPGA image (field programmable gateway array). What is new is that this FPGA image can be updated.

There are two FPGA images in the flash on the board:

- Safe FPGA image: located in the read-only sector of the flash and cannot be overwritten/updated.
- Update-enabled FPGA image: located in the writeable sector of the flash and can be updated.

IMPORTANT: The update-enabled FPGA image cannot overwrite the safe FPGA image.

An FPGA image is therefore also distributed when the loadware is loaded on the LTUCR board. The loadware file contains the loadware image and the FPGA image. The FPGA image on the LTUCR board is only updated then when the loadware file contains a new version of the FPGA firmware.

If the loadware file contains a new FPGA image, this new FPGA image is loaded automatically onto the board. The LTUCR board is reset automatically via the system software to activate this image, with the result that all boards in the affected shelf fail.

IMPORTANT: The information provided in the Release Note must be observed if the LTUCR loadware is included in a hot fix/fix release. The Release Note also provides information on whether a new FPGA image is contained in the loadware!

The subsequent starting up of the newly loaded LTUCR boards and connected peripheral boards for the FPGA image may take a long time depending on the system configuration (individual shelf startup).

An FPGA image update is envisaged as an extremely rare operational event.

6.4 SIUX3

The signaling interface unit peripheral extended (SIUX and SIUX2) boards transmit and receive DTMF or MFC signals on eight channels to and from trunks and subscriber equipment. They also perform line diagnostic tests. The SIUX and the SIUX2 have exactly the same functionality. The SIUX2 is the replacement for the older board.

Previous models of the SIUX board had SIVAPAC connectors. The New SIUX2 board has SIPAC connector. This board cannot be used as a central SIU.

This board has six operating modes, each using different loadware.

- Function ID 2 provides eight DTMF sender/receiver pairs for use in countries that employ DTMF signalling.
- Function ID 3 provides eight MFC sender/receiver pairs for use in countries that employ MFC signalling.
- Function ID 4 provides four DTMF sender/receiver pairs, plus one port containing the Telephony Diagnostic System (TDS).
- Function ID 5 provides MFC ANI services for use in Russia and other CIS countries.
- Function ID 6 provides MFC shuttle-packet services for use in Russia and other CIS countries.
- Function ID 7 provides four DTMF sender/receiver pairs, plus one port containing the Line check diagnostics.

The order number for SIUX3 is S30810-Q2287-X.

6.4.1 LED Indications

The front panel of the SIUX and SIUX2 board (see [Figure 30](#)) has two LEDs: ERR (error) and RDY (ready).

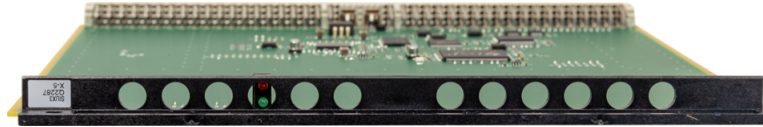

Figure 30: SIUX Board Front Panel

[Table 12](#) lists the LED indications of the SIUX board.

Table 19: SIUX Board LED Indications

LED	State	Indication
Ready (Green)	On	Board is active.
	Off	Board is not initialized or has a fatal error.
Error (Red)	On	Initial board test is in progress or a fatal board error is detected.
	Flashing	Board loadware is loading or the initial board test passed.
	Off	Board is functioning normally.

6.4.2 Removing the SIUX Board

IMPORTANT: All DTMF tones supported by the SIUX board are removed from service. If the first SIUX in the system is removed, the DTMF tones that support HSD are removed and HSD is unavailable.

NOTICE: Static Sensitive Devices! Observe all precautions for electrostatic discharge.

Remove the SIUX board as follows:

- 1) Deactivate the SIUX board as follows:
 - a) Type `DEA-BSSU` and press Enter.
 - b) Type the following values, then press Enter.

Field	Value
OFFTYPE	DC
LTG	1
SLOT	<slot number>

REOFF	<blank>
-------	---------

- 2) Display the telephony boards as follows:
 - a) Type DIS-BCSU and press Enter.
 - b) Type the following values, then press Enter.

Field	Value
TYPE	TBL
LTG	1
SLOT	<slot number>

- 3) Using the board extractor, unseat the board and remove it from the shelf.

6.4.3 Replacing the SIUX Board

Replace the SIUX board as follows:

- 1) Slide the board into the appropriate slot until you seat it firmly into the backplane connector.
- 2) Activate the SIUX board as follows:
 - a) Type ACT-BSSU and press Enter.
 - b) Type the following values, then press Enter.

Field	Value
ONTYPE	AUL
LTG	1
SLOT	<slot number>

6.4.4 Verifying the SIUX Board

Verify the operation of the SIUX board by displaying the status of the shelf as follows:

- 1) Type DIS-SDSU and press Enter.
- 2) Type the following values, then press Enter.

Field	Value
STATUS	ALL
LINK	<blank>
TYPE	PEN
LTG	1
LTU	<ltu#>
SLOT	<slot#>

6.5 SLMAV

The SLMAV (**S**ubscriber **L**ine **M**odule **A**nalog **V**inetic) board is an analog T/R interface. The board is not downward compatible with old HiPath 4000 systems before V4.

IMPORTANT: SLMAV replaces the SLMAC and SLMAE variants.

6.5.1 Functional description

SLMAV has the same features as the SLMAE board. It provides analog T/R interfaces for use in OpenScape 4000. The SLMAV board is available for OpenScape 4000 in the following variant:

- SLMAV (S30810-Q2227-X) = 24 analog T/R interfaces

The SLMAV board supports calling name identification presentation (CLIP). This board generates its own ring voltages (71 Vrms) and does not require an external ring voltage generator. SLMAV supports a line loop resistance of 1800 Ohms - line distance of 4.5km for a standard 600Ohms telephone. Other line impedances see below:

Table 20: Other line impedances

		Max. length #AWG24 / 84,19Ω / km		Max. length #AWG26 / 133,85Ω / km		Max. length "giga" / 280Ω / km	
Phone/Device:							
Board	loop resistance (telephone included)	300 Ω	600 Ω	300 Ω	600 Ω	300 Ω	600 Ω
SLMAV	1800 Ω	17,82 km	14,25 km	11,21 km	8,96 km	5,36 km	4,29 km

The board functions are:

- Overvoltage protection
- Ringing the line
- Supervising and signaling the line
- Codec function
- Hybrid function 2W to 4W and 4W to 2W
- Test (loopback) capability

Other characteristics:

Table 21: Other SLMAV characteristics

	SLMAV
1800 Ω loop resistance (telephone included)	√
32 mA current loop	√

	SLMAV
40 mA current loop	√
Adjustable current	√
Adaptive DC-feed	
75 Vrms balanced ring	√
3 ROW REN / 2 US REN ring load @ 00hm length	√
1 REN ring load @ 1500 Ohm length	√
10 REN ring load per board	√
DMTF detection* (on chip)	√
Caller ID FSK ETSI Types 1 & 2	√
Caller ID DTMF: ETSI Types 1 & 2, DNK, BRA, Bellcore MDMF & SDMF	√
MWI FSK ETSI, Bellcore MDMF & SDMF	√
MWI Comtel3	√
MWI Neon	√
Modem tone detection	√
Modem V.90 data transmission	√
Calculable impedance for each country	√

Service Information

When using old analog devices on SLMAV boards that use a Ground Key for consultation, then COFIDX 6 must be set for the function to work correctly.



Figure 31: SLMAV

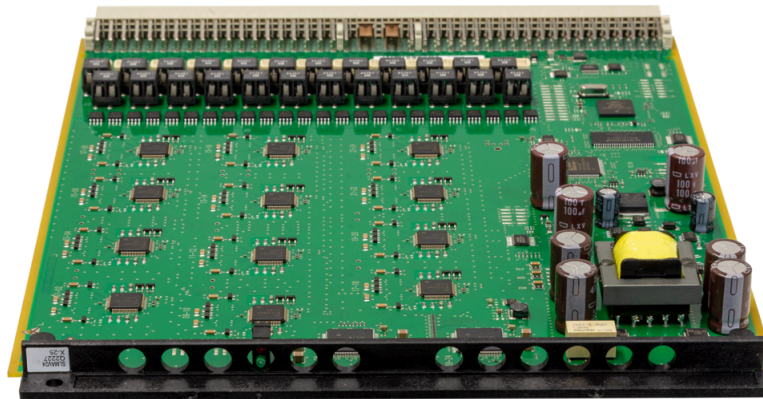

Figure 32: SLMAV board

6.5.2 LED Indications

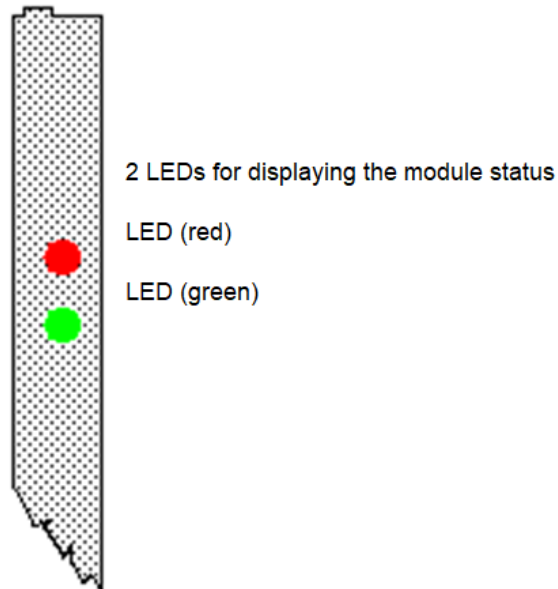

Figure 33: SLMAV - Front Panel

IMPORTANT: To ensure sufficient shielding, provide the board with a shielding panel.

The LEDs activation and cadence of the blinking have different meanings, according to the software components FW or LW which executes on the board.

6.5.2.1 Function under FW

Table 22: LED Statuses and Their Meanings under FW

Red LED	Green LED	Status
ON	Flashing	BIST Mode
Flashing	OFF	Hardware Error

6.5.2.2 Function under LW

Table 23: LED Statuses and Their Meanings under LW

Red LED	Green LED	Status	Action
Off	Off	Board not receiving power or not plugged in correctly. Board is out of order.	Check plug contact on board.
On	Off	Board is receiving power and board test is in progress. Board is defective if status remains unchanged (fatal HW/LW error).	Replace board.
		Loadware loading not successfully completed. Board is faulty.	Replace board.
		Error detected on board. Board is deactivated (not applicable to errors detected by test loops) or board was deactivated using OpenScape 4000 Manager.	Check whether the board was deactivated using OpenScape 4000 Manager . If not, replace board.
Flashing	Off	Loadware is being loaded.	
Off	On	Board test completed successfully. Board is OK (idle state).	
Off	Flashing	At least one subscriber line circuit is activated.	

The Power Supply of +5Vdc/-54Vdc will be provided over the System Backplane.

6.5.3 Removing SLMAV Board

IMPORTANT: This procedure removes up to 24 analog voice channels from service.

NOTICE: Static Sensitive Devices! Observe all precautions for electrostatic discharge.

Remove SLMAV board as follows:

1) Deactivate all channels on the board as follows:

- a) Type `DEA-DSSU` and press Enter.
- b) Type the following values, then press Enter.

Field	Value
OFFTYPE	DC
TYPE	PEN
PEN1	<PEN1>
PEN2	<PEN2>

IMPORTANT: PEN1 is the pen of the first channel and PEN2 is the pen of the last channel on the board.

2) Display the status of the board until all channels are free as follows:

- a) Type `DIS-SDSU` and press Enter.
- b) Type the following values, then press Enter.

Field	Value
STATUS	ALL
LINK	<blank>
TYPE	PEN
LEVEL	PER3
LTG	<1 - 32>
LTU	<1 - 8>
SLOT	<1 - 151>
CCT	<0 - 15>

3) When all channels are available, deactivate the board as follows:

- a) Type `DEA-BSSU` and press Enter.
- b) Type the following values, then press Enter.

Field	Value
OFFTYPE	DC
LTG	<1>
LTU	<1 - 8>
SLOT	<1 - 121>
REFOFF	<blank>

4) Using the board extractor, unseat the board and remove it from the shelf.

6.5.4 Replacing SLMAV Board

Replace the SLMAV board as follows:

- 1) Slide the board into the appropriate slot until you seat it firmly into the backplane connector.

2) Activate the SLMAV board as follows:

a) Type ACT-BSSU and press Enter.

b) Type the following values, then press Enter.

Field	Value
ONTYPE	AUL
LTG	<1 - 32>
LTU	<1 - 8>
SLOT	<1 - 151>

3) Activate the channels on the board as follows:

a) Type ACT-DSSU and press Enter.

b) Type the following values, then press Enter.

Field	Value
ONTYPE	AUL
TYPE	PEN
PEN1	<PEN1>
PEN2	<PEN2>

IMPORTANT: PEN1 is the pen of the first channel and PEN2 is the pen of the last channel on the board.

6.5.5 Verifying the SLMAV Board

Verify the operation of the SLMAV board by displaying the status of the board as follows:

1) Type DIS-SDSU and press Enter.

2) Type the following values, then press Enter.

Field	Value
STATUS	ALL
LINK	<blank>
TYPE	PEN
LEVEL	PER3
LTG	<1 - 32>
LTU	<1 - 8>
SLOT	<1 - 151>
CCT	<0 - 15>

The SLMAV board is automatically tested on activation.

6.5.6 MDF Assignments

- For connecting to the SIVAPAC connector on the backplane: [Table 17](#)
- For connecting to the connector panels using RJ45 jacks: [Table 18](#)
- For U.S. only: For connecting to the connector panels with a CHAMP jack: [Table 19](#)

Table 24: SLMAV - SIVAPAC Connector Assignment on the Backplane

Pair	a-Wire (Tip)	b-Wire (Ring)	SIVAPAC Connector	SLMAE8, SLMAE		MDFU-E
1	wht/blu		1	1a	Port 1	1a
		blu/wht	23	1b		1b
2	wht/ora		3	2a	Port 2	2a
		ora/wht	4	2b		2b
3	wht/grn		5	3a	Port 3	3a
		grn/wht	6	3b		3b
4	wht/brn		7	4a	Port 4	4a
		brn/wht	8	4b		4b
5	wht/gry		9	5a	Port 5	5a
		gry/wht	10	5b		5b
6	red/blu		11	6a	Port 6	6a
		blu/red	12	6b		6b
7	red/ora		13	7a	Port 7	7a
		ora/red	14	7b		7b
8	red/grn		15	8a	Port 8	8a
		grn/red	16	8b		8b
9	red/brn		17	9a	Port 9	9a
		brn/red	18	9b		9b
10	red/gry		19	10a	Port 10	10a
		gry/red	20	10b		10b
11	blk/blu		24	11a	Port 11	11a
		blu/blk	25	11b		11b
12	blk/ora		26	12a	Port 12	12a
		ora/blk	27	12b		12b
13	blk/grn		29	13a	Port 13	13a
		grn/blk	30	13b		13b
14	blk/brn		31	14a	Port 14	14a
		brn/blk	32	14b		14b

Pair	a-Wire (Tip)	b-Wire (Ring)	SIVAPAC Connector	SLMAE8, SLMAE		MDFU-E
15	blk/gry		34	15a	Port 15	15a
		gry/blk	35	15b		15b
16	yel/blu		37	16a	Port 16	16a
		blu/yel	38	16b		16b
17	yel/ora		43	17a	Port 17	17a
		ora/yel	44	17b		17b
18	yel/grn		45	18a	Port 18	18a
		grn/yel	46	18b		18b
19	yel/brn		47	19a	Port 19	19a
		brn/yel	48	19b		19b
20	yel/gry		49	20a	Port 20	20a
		gry/yel	50	20b		20b
21	vio/blu		51	21a	Port 21	21a
		blu/vio	52	21b		21b
22	vio/ora		53	22a	Port 22	22a
		ora/vio	54	22b		22b
23	vio/grn		55	23a	Port 23	23a
		grn/vio	56	23b		23b
24	vio/brn		57	24a	Port 24	24a
		brn/vio	58	24b		24b

Table 25: SLMAV - Connector Panel Assignment with RJ45 Jacks

RJ45 jack		SLMAE8, SLMAE
No.	Pin	
1	4	1a
	5	1b
2	4	2a
	5	2b
3	4	3a

Boards

RJ45 jack		SLMAE8, SLMAE
No.	Pin	
	5	3b
4	4	4a
	5	4b
5	4	5a
	5	5b
6	4	6a
	5	6b
7	4	7a
	5	7b
8	4	8a
	5	8b
9	4	9a
	5	9b
10	4	10a
	5	10b
11	4	11a
	5	11b
12	4	12a
	5	12b
13	4	13a
	5	13b
14	4	14a
	5	14b
15	4	15a
	5	15b
16	4	16a
	5	16b
17	4	17a

RJ45 jack		SLMAE8, SLMAE
No.	Pin	
	5	17b
18	4	18a
	5	18b
19	4	19a
	5	19b
20	4	20a
	5	20b
21	4	21a
	5	21b
22	4	22a
	5	22b
23	4	23a
	5	23b
24	4	24a
	5	24b

Table 26: SLMAV - Connector Panel Assignment with a CHAMP Jack (for U.S. only)

CHAMP jack	SLMAE8, SLMAE		
1	1a	1 Ring	Port 1
26	1b	1 Tip	
2	2a	2 Ring	Port 2
27	2b	2 Tip	
3	3a	3 Ring	Port 3
28	3b	3 Tip	
4	4a	4 Ring	Port 4
29	4b	4 Tip	
5	5a	5 Ring	Port 5
30	5b	5 Tip	

Boards

CHAMP jack	SLMAE8, SLMAE		
6	6a	6 Ring	Port 6
31	6b	6 Tip	
7	7a	7 Ring	Port 7
32	7b	7 Tip	
8	8a	8 Ring	Port 8
33	8b	8 Tip	
9	9a	9 Ring	Port 9
34	9b	9 Tip	
10	10a	10 Ring	Port 10
35	10b	10 Tip	
11	11a	11 Ring	Port 11
36	11b	11 Tip	
12	12a	12 Ring	Port 12
37	12b	12 Tip	
13	13a	13 Ring	Port 13
38	13b	13 Tip	
14	14a	14 Ring	Port 14
39	14b	14 Tip	
15	15a	15 Ring	Port 15
40	15b	15 Tip	
16	16a	16 Ring	Port 16
41	16b	16 Tip	
17	17a	17 Ring	Port 17
42	17b	17 Tip	
18	18a	18 Ring	Port 18
43	18b	18 Tip	
19	19a	19 Ring	Port 19
44	19b	19 Tip	
20	20a	20 Ring	Port 20

CHAMP jack	SLMAE8, SLMAE		
45	20b	20 Tip	
21	21a	21 Ring	Port 21
46	21b	21 Tip	
22	22a	22 Ring	Port 22
47	22b	22 Tip	
23	23a	23 Ring	Port 23
48	23b	23 Tip	
24	24a	24 Ring	Port 24
49	24b	24 Tip	

6.6 SLMU

SLMU replaces discontinued components SLMO and SLMOP by new ones. The new board can only be used with an OpenScape 4000 SW version V7 R2.x.x and above. The board is not downward compatible to be used with older system SW versions.

The order number for SLMU is S30810-Q2344-X100.

6.6.1 Board Variants

Table 27: Assignment of the Boards

1) The length of the telephone connection lines depends on the type of cable used. The 1000 m is the maximum loop length in accordance with ICCS (Integrated Communications Cabling System).

Name	Replacemen of	Part number	Q-number (Part number)	UP0/E port	Cable length
SLMU	SLMO24 (Q2168-X)	S30810-Q2344-X100	Q2344-X100	24	up to 1000m 1)
OSA SLO (SLMU)	OSA SLO (Q2333-X)	S30807-U6648-X111	Q2345-X100	24	up to 1000m 1)



Figure 34: SLMU - self variant

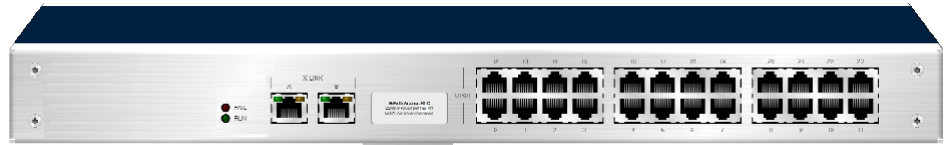

Figure 35: OSA SLO (SLMU) - OSA variant

6.6.2 LED Indications

A green and a red LED labeled “RUN” and “FAIL” report the general status of the OSA box. RUN LED is set by default when the board is powered on, while FAIL LED must be off all the time.

6.6.3 Interfaces

- UP0/E interface is a two-wire ISDN Basic Rate 2B+D interface. A total of 24 UP0/E ports are available per board.
- PCM interface
- HDLC interfaces (High Level Data Link Control)

6.6.4 Power Supply

The power supply provided to SLMU comes from an external power supply unit residing in the shelf. The voltages available to SLMU are -48V and the +5V. Most of the chips are +3.3V technology, being the only exception the driver to backplane interface.

6.7 SLMC

SLMC replaces discontinued components SLC24 by new ones. The new boards can only be used with an OpenScape 4000 SW version V7 R2.x.x and above. The boards are not downward compatible to be used with older system SW versions.

6.7.1 Board Variants

SLMC board refer to all variants of the peripheral board basis: SLMC (Subscriber Line Module Cordless) and OpenScape Access SLC-M (OSA SLC-M). SLMC has 24 UP0/E interfaces for connecting DECT cordless base stations.

Table 28: Assignment of the Boards

Name	Replacement of	Part number	Q-number (Part number)	UP0/E port	Cable length	ADPCM channels
SLMC	SLC24 (Q2193-X200)	S30810-Q2344-X	Q2344-X	24	up to 1000m ¹	48
OSA SLC-M	OSA SLC (Q2334-X200)	S30807-U6648-X125	Q2345-X	24	up to 1000m ¹	48

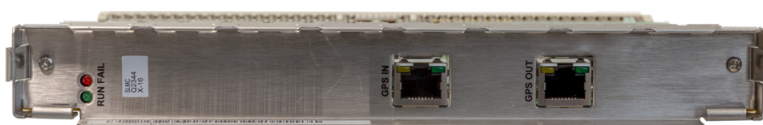

Figure 36: SLMC - shelf variant



Figure 37: OSA SLC-M - OSA variant

6.7.2 LED Indications

A green and a red LED labeled “RUN” and “FAIL” report the general status of the OSA box. RUN LED is set by default when the board is powered on, while FAIL LED must be off all the time.

Other LED indicators are located on the front panel of OSA SLC-M box - detailed description can be found in **OpenScape Cordless Enterprise V7**, Service Documentation, sections 6.3.3 Indications in SLC-M (LEDs labeled “CLK_XX”) and 9.2.2.3 LEDs (LEDs labeled “GPS_XX”).

6.7.3 Interfaces

- UP0/E interface is a two-wire ISDN Basic Rate 2B+D interface. A total of 24 UP0/E ports are available per board. A maximum power feeding current of 85mA is guaranteed in order to accommodate the requirements of the CMI basestations (DECT).
- ADPCM - the ADPCM module (on CMAe) is responsible for processing of 48 ADPCM channels and must encode/decode the ADPCM streams in order to be processed in the echo module (echo processing means echo

¹ The length of the telephone connection lines depends on the type of cable used. The 1000 m is the maximum loop length in accordance with ICCS (Integrated Communications Cabling System)

suppression, echo cancellation, artificial echo and modem tone detection). ADPCM is responsible for the DECT voice processing.

- PCM interface
- HDLC interfaces (High Level Data Link Control)
- SLCSS interface (Subscriber Line Cordless Synchronization module Small) - on (OSA-)SLMC offers ISS functionality for the Multi-SLC solution. It is responsible for GPS clock synchronization in large cordless systems.

6.7.4 Power Supply

The power supply provided to SLMC comes from an external power supply unit residing in the shelf. The voltages available to SLMC are -48V and the +5V. Most of the chips are +3.3V technology, being the only exception the driver to backplane interface.

6.8 STMD3

STMD3 Station/Trunk Module Digital S0+SLMS2 Station Line Module Digital S0.

STMD3 provides the STMD and SLMS functions on a single board. STMD2 provides all of the features offered by predecessor modules. It features eight trunks with S0 interfaces. Each S0 interface (4-wire) provides basic access with two B channels (each with 64 kbit) for voice/data transmission and one D channel (16 kbit).



CAUTION: For lightning protection see [Section 2.3, "Lightning Protection"](#).

The STMD3 and STMD2 boards are identical in terms of function. A new board with a new source number has been introduced because new components are being used.

Restrictions with STMD3:

The range with a short bus (1..8 TEs distributed on the cable) is limited to about 60 meters. If the customer does not require longer cables, no further parameter changes are needed.

To enable the use of greater cable lengths, set the parameter EXTBUS=YES in AMO SBCSU. With this setting, a cable length of up to 160 meters is possible.

STMD3 board description:

- Moreover the new boards use SIPAC connector to the backplane.
- The front panel of the board contains 2 LEDs.
- Flashprotection is on board.
- The cabling to the MDF differs to the SLMS and STMD solution. STMD2 use a 24-twisted-wire cable with no protection.

6.8.1 Board Variants

STMD3

The two variants for the STMD3 board are:

- Q2217-X: trunk/subscriber card (without power supply)
- Q2217-X100: subscriber card (with power supply)

6.8.2 LED Indications

Flashing: 500ms on - 500ms off

Table 29: LED Indications

Red-LED (Top)	Green-LED (Lower)	Indications
On	Off	Initial power on
Flashing	Off	Loading
On	Off	Defective
Off	On	All circuits idle (no circuit has established a Layer2 connection)
Off	Flashing	At least one circuit busy (at least one circuit has established a Layer2 connection)

6.9 STMIX

The STMIX(Subscriber Trunk Module IP eXtended) board is used as Common Gateway HG 3500.



CAUTION: For lightning protection see [Section 2.3, "Lightning Protection"](#).

The STMIX board offers the following central and peripheral functions:

- Two network accesses to 1 GB Ethernet
- Voice encoding functions (based on x86 CPU)
- Backplane interface for a default peripheral board
- USB slave interface for test access (test interface)

IMPORTANT: The STMIX is allowed to be hot plugged.

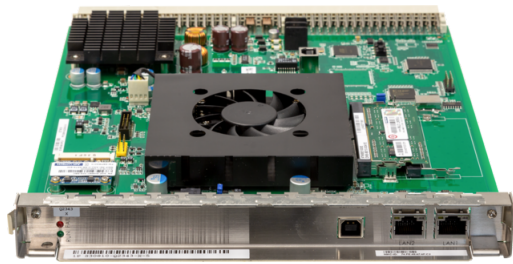

Figure 38: STMIX board

6.9.1 System Diagram

Figure 39 shows a system diagram of the STMIX board.

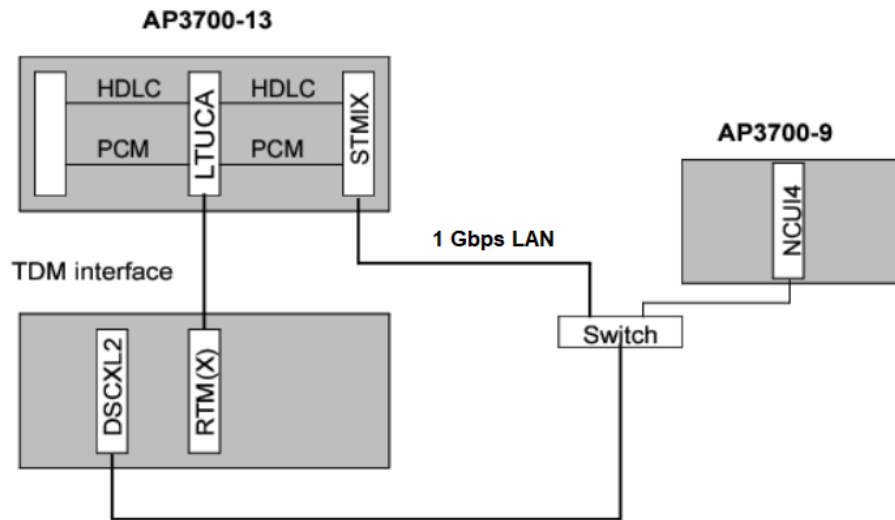

Figure 39: STMIX Board, System Diagram

6.9.2 Board Variants and Modules

Table 30: STMIX - Boards variants and modules

STMIX with a PDMX (PMC DSP Module Extended):	S30810-Q2343-X
--	----------------

6.9.3 LED Displays and Interfaces

Table 24 lists the LED displays and interfaces that are configured on the front of the board for service purposes:

Table 31: LED Displays and Interfaces

Quantity	LEDs and interfaces	Indications and Purpose
1	USB - type B connector	
1	Green LED	
1	Red LED	
2	LEDs: LED1: green On = 100 Mbps	For each LAN interface (integrated in the RJ45 connector)
	LED2: green green = online (link) wink = active	On = full-duplex (FDX); Off = half-duplex

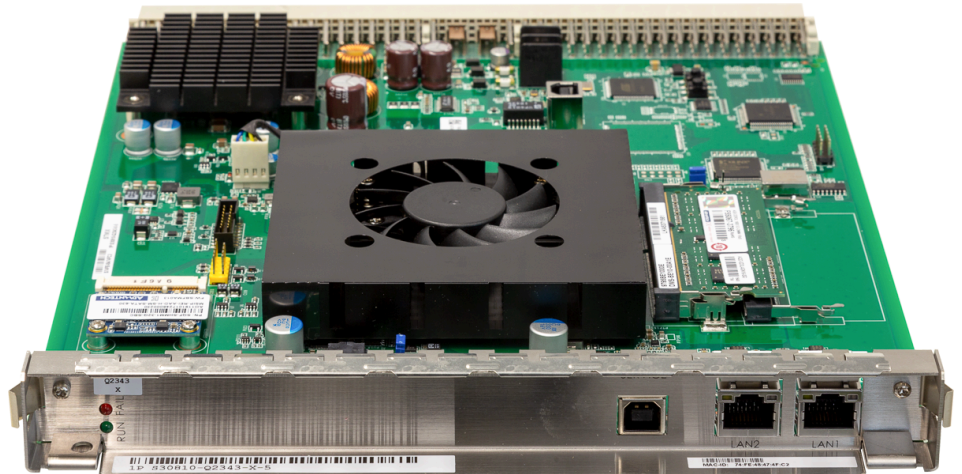

Figure 40: STMIX Board

6.9.4 Power Supply

The supply input voltage of the x86 part is +12V, however the +12V rail of a HiPath 4000 backplane doesn't provide sufficient power. The -48V rail is used, and a 30W DC/DC converter module converts from -48V to +12V.

XBA section input is +5V, taken from the backplane, including the staggered pre-charge contact, to allow hot plugging.

IMPORTANT: Although LUNA2 power supply is self-protecting, it is possible to operate maximum four STMIX boards parallel with one LUNA2 power supply.

Boards

How to recover a STMIX board

6.9.5 Restrictions

Standby board HG 3500 and QDC is supported (from V8R1).

Features not supported:

- LW loading via (HDLC) backplane (only loading over Assistant GW manager is supported)
- WAML
- G.722, G.723 and OPUS codecs
- SNMP Call Statistic (RG2500 private MIB anno 1998)
- QDC (Quality Data Collection)
- H323 trunking (exception Xpressions connectivity is supported)
- SIP load balancer service (only on SoftGate)
- Rpcap and Assistant IP tracer support.
- FIPS 140-2
- AP1120 (vHFA has no FMoIP support)
- Assistant HBR HG3550M Backup Sets from STMI2/4 are not compatible with STMIX (and vice versa). Means that existing backup sets (e. g. containing SPE certificates, SIP Trunk Profile configurations, etc.) cannot be restored on STMIX. Hence this restriction has further effect on "Standby HG3500" feature (see IP Solutions for further details).

IMPORTANT: Starting with V10R0 the support for STMI2 will not be offered anymore. The replacement for STMI2 is STMIX.

6.10 How to recover a STMIX board

6.10.1 General description

The STMIX can be re-flashed in case the board is not booting or not becoming READY in RMX.

The process can also be used to factory reset an STMIX board. All customer saved data will be erased from the board.

Hardware and cabling requirements

- PC or Notebook with Windows OS: A connection must be established between the PC/Notebook and the STMIX board via a LAN cable connected to STMIX LAN1.

In the example provided in this document the STMIX uses the 192.0.2.101 IP address. It is strongly recommended for the PC to use **192.0.2.100** with netmask 255.255.255.0. Do NOT configure any other IP address on the same interface to avoid issues.

INFO: It is possible to use a secondary PC network interface if available.

- USB cable, type A to type B cable (e.g. USB printer cable): connect the Windows PC via USB (type A) and the STMIX via USB (type B).

- STMIX in OpenScape 4000, any type shelf: AP37009, AP370013, LTUW, etc.

Software requirements

- DHCP Server + TFTP Server: e.g. tftpd64.exe from <https://tftpd64.software.informer.com/download/>

INFO: Use the 32 bit version in case of 32 bit Windows OS.

- HTTP fileserver: e.g. HFS.exe from <https://www.rejetto.com/hfs/?f=dl>
- Decompression tool which supports .exe and .gz unzipping: e.g. 7zip.
- SSH client (e.g. Putty) for SSH access to OpenScape 4000 and for COM port access to STMIX via USB port.
- SFTP client (e.g. WinSCP) for downloading files from the OpenScape 400 platform.
- STMIX USB Driver from OS4K Installation ISO: e.g. OS4K_V10_R0.28.0_InstallImage.iso\DriversAndTools\STMIX_USB_Serial_Console_Driver\
- JeOS image for STMIX, generated on the OS4K Linux platform.

NOTICE: Minimum required OS4K PLT version: V8 R2.22.9 or V10 R0.28.5.

6.10.2 Preparing the necessary files

- 1) Create a working folder on the PC (e.g. D:\stmix-image-repo) and copy the HTTP fileserver (hfs.exe) and the TFTP/DHCP server (tftpd64.exe).

NOTICE: The tftpd64.exe file can be either installed or extracted from the installer (using 7-zip) and copied to the working folder. The hfs.exe does not require installation.

- 2) Connect with SSH to the Platform Linux of any OS4K deployment type (Simplex, Duplex, Survivable, Standalone etc.) and generate the STMIX image with the following command:

```
bash /opt/yaps/create_stmix_PXE_boot_image.sh
```

The result will be saved on the OpenScape 4000 Platform Linux, under the following path: /stmix-image-repo.
- 3) The generated files must be copied to the working folder created on the PC (D:\stmix-image-repo) via SFTP client.
- 4) Select and right-click on the .pxeboot file, then choose 7-Zip "Open archive" option. Now double click and open the shown .tar.gz file.
- 5) Extract the contents using "Extract" option (or drag drop the folder contents) to the working folder (D:\stmix-image-repo).
- 6) The working folder should now contain the following files:

```
STMIX_JeOS_SLES11_SP4.x86_64-V10_R0.28.0.tar.gz
STMIX_JeOS_SLES11_SP4.x86_64-V10_R0.28.0.tar.gz.md5
STMIX_JeOS_SLES11_SP4.x86_64-V10_R0.28.0.tar.gz.pxeboot
pxelinux.cfg\default
initrd
menu.c32
```

```
pxelinux.0  
vmlinuz  
hfs.exe  
tftpd64.exe
```

INFO: A folder with Paxheaders may also be generated, but it can be ignored.

NOTICE: The file "D:/stmix-image-repo/pxelinux.cfg/default" is preconfigured for the network 192.0.2.0/24. If the default values are not used, the file must be edited in order to match the IP configuration.

6.10.3 Tool configuration for flashing

NOTICE: It is recommended to run the tools as administrator. Otherwise, the settings may not be saved.

Tool configuration:

- 1) Run the webserver hfs.exe file:

Menu -> Add files

Select and open the following files from the "D:/stmix-image-repo" folder:

```
STMIX_JeOS_SLES11_SP4.x86_64-V10_R0.28.0.tar.gz  
STMIX_JeOS_SLES11_SP4.x86_64-V10_R0.28.0.tar.gz.md5
```

Menu -> IP Address

Select the IP address used on the interface connected to the STMIX LAN port (e.g. 192.0.2.100).

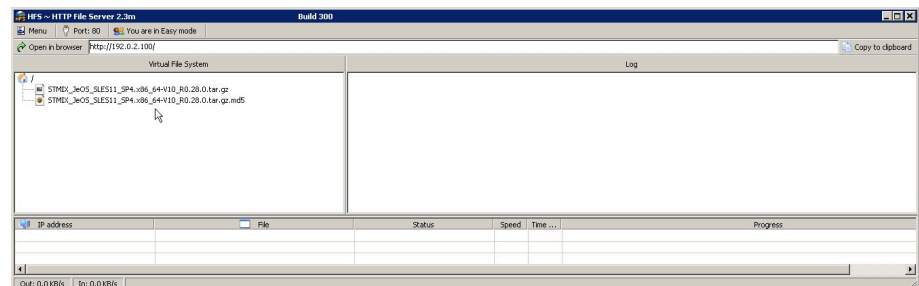

Figure 41: IP settings for hfs.exe

2) Run the tftpd64.exe. Make sure the following settings are in place:

- **Current directory:** D:\stmix-image-repo

Server interfaces: select the interface connected with the STMIX

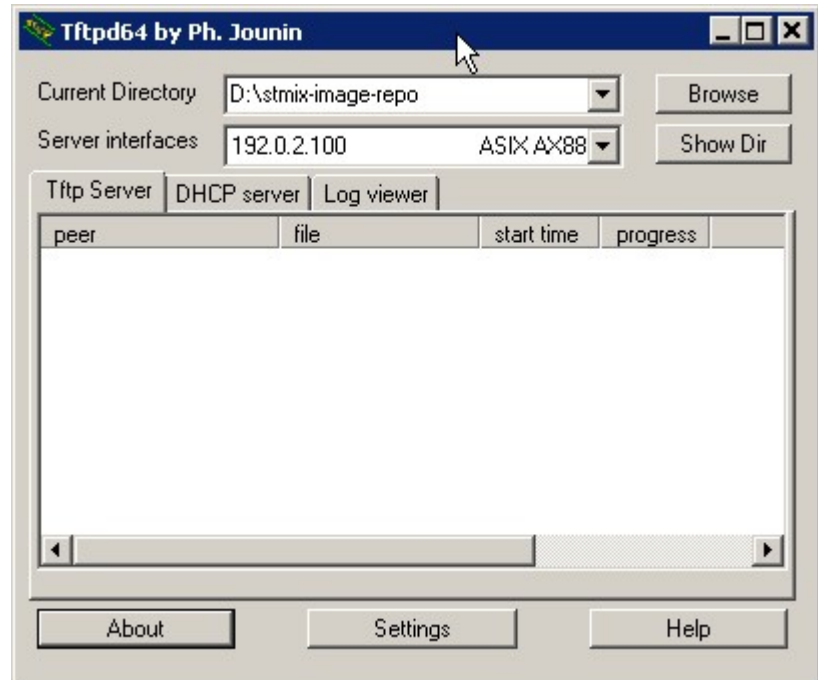

Figure 42: Settings for tftpd64.exe

- **Under the GLOBAL tab ensure:**
 - The “TFTP Server” box is checked.
 - The “DHCP Server” box is checked.

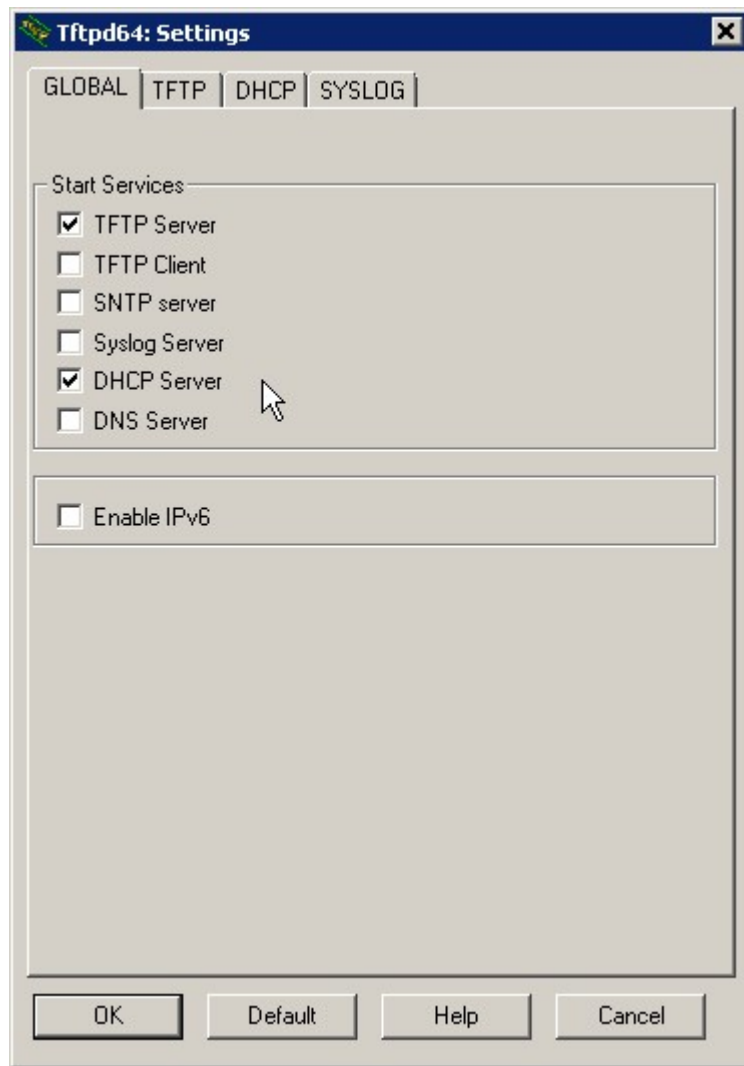

Figure 43: GLOBAL settings for tftpd64.exe

- **Under the TFTP tab ensure:**
 - The Base Directory is set to "D:/stmix-image-repo".
 - The "PXE Compatibility" box is checked.
 - The "Bind TFTP" box is checked and the IP address of Windows PC Lan interface connected to STMIX is selected from the drop down menu.

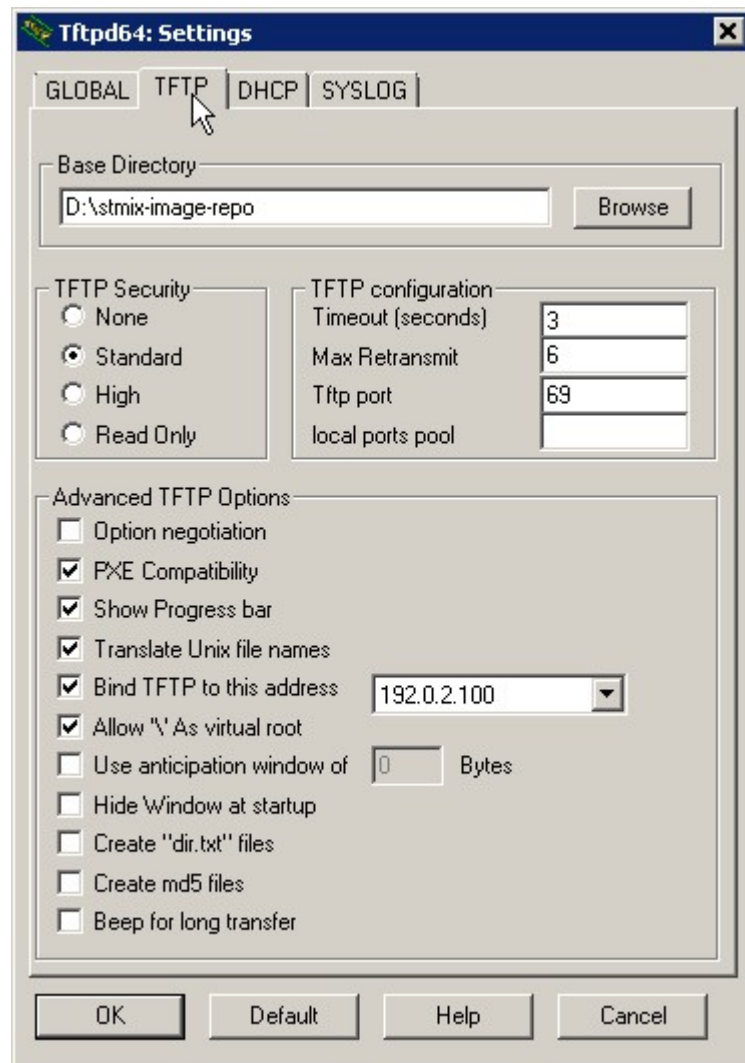

Figure 44: TFTP settings for tftpd64.exe

- **Under the DHCP tab ensure:**
 - IP pool start address: IP Address of STMIX (e.g. 192.0.2.101)
 - Size of pool: 1
 - Boot file: pxelinux.0
 - Mask: 255.255.255.0
 - Persistent leases: box must not be checked
 - Bind DHCP to this address: IP of Windows PC LAN interface connected to the STMIX (e.g. 192.0.2.100)

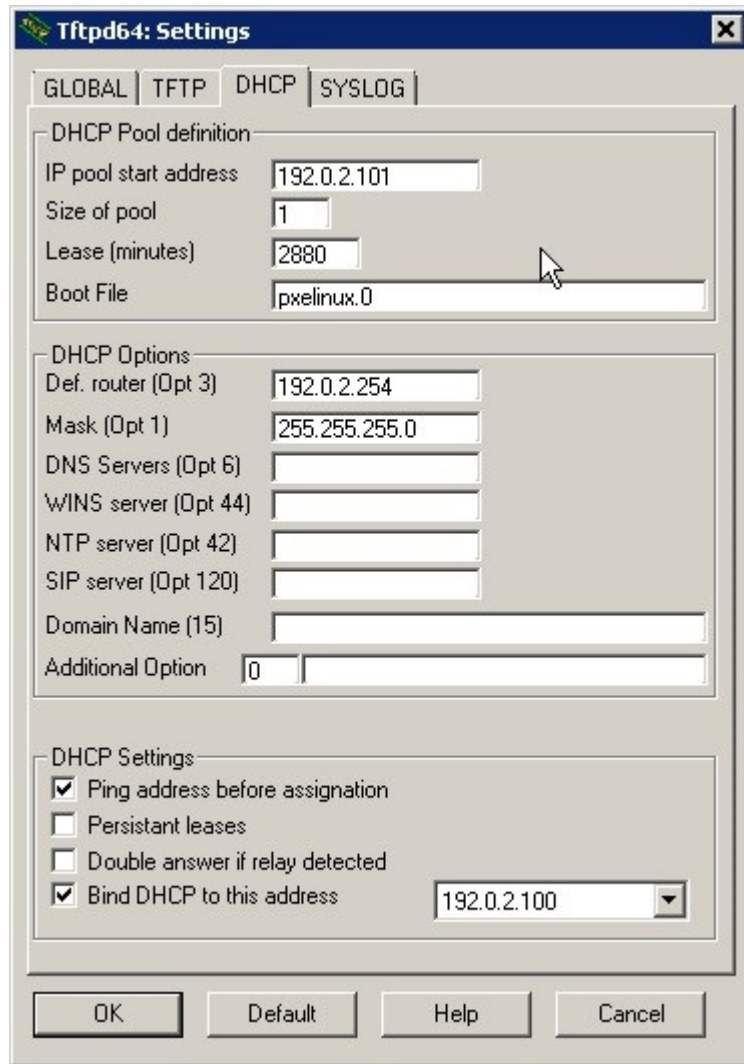

Figure 45: DHCP settings for tftpd64.exe

IMPORTANT: After proceeding with the above steps, exit and restart the tftpd64 tool to initialize the configured settings.

6.10.4 STMIX USB configuration

USB Terminal

Install the STMIX USB driver on the Windows PC.

With the USB cable connected and the STMIX board powered on, identify the COM port allocated to the STMIX in the Device Manager of Windows PC:

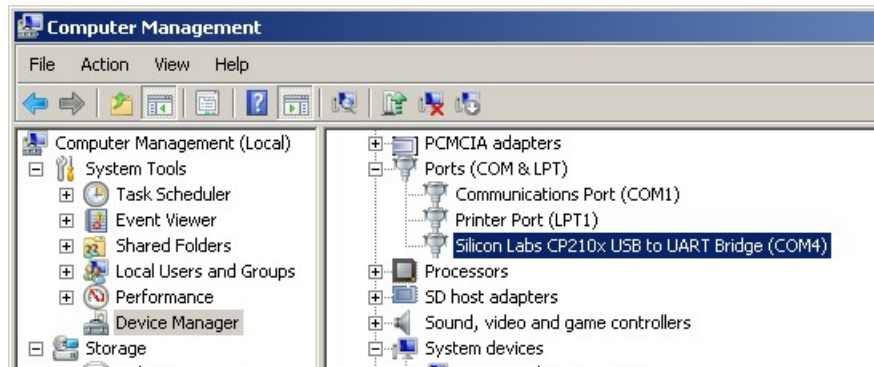

Figure 46: Device Manager, COM port

Configure in PuTTY a new connection for the identified COM port. The Serial port should be configured with "115200", "8", "1", "None", "None" values.

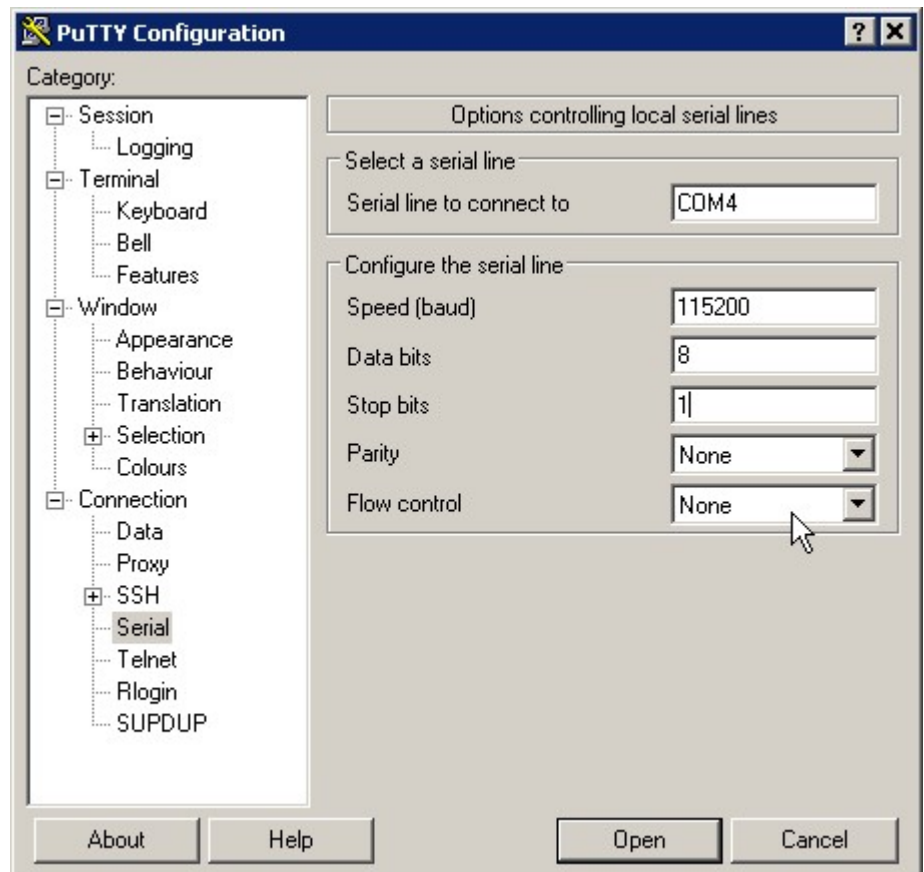

Figure 47: PuTTY configuration

The Keyboard should be set to type "Linux", shown under "The Function keys and keypad".

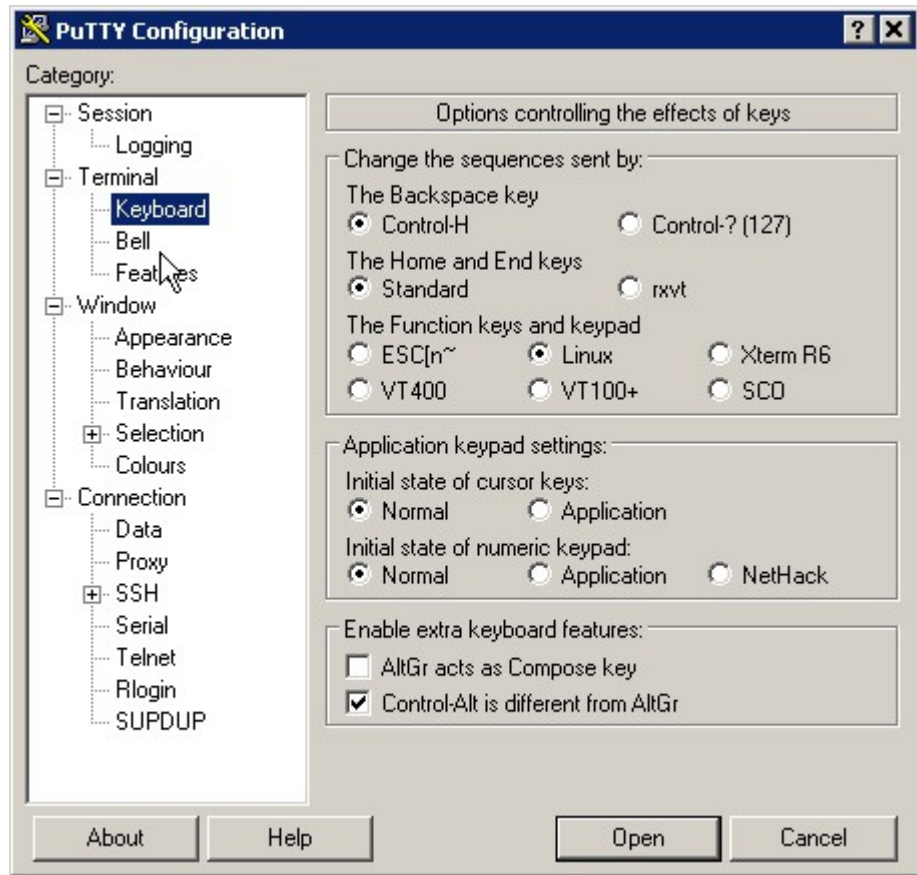

Figure 48: Settings for the keyboard

Save the session. You can now connect to the STMIX USB-COM. The username is TRM and the password is as configured in AMO CGWB.

6.10.5 STMIX re-flash

- 1) Reboot the STMIX via SSH or power cycle the card via re-plug.

2) Ensure the STMIX BIOS settings.

In the terminal you will see the STMIX booting. Immediately press ESC or DEL to access the BIOS Setup.

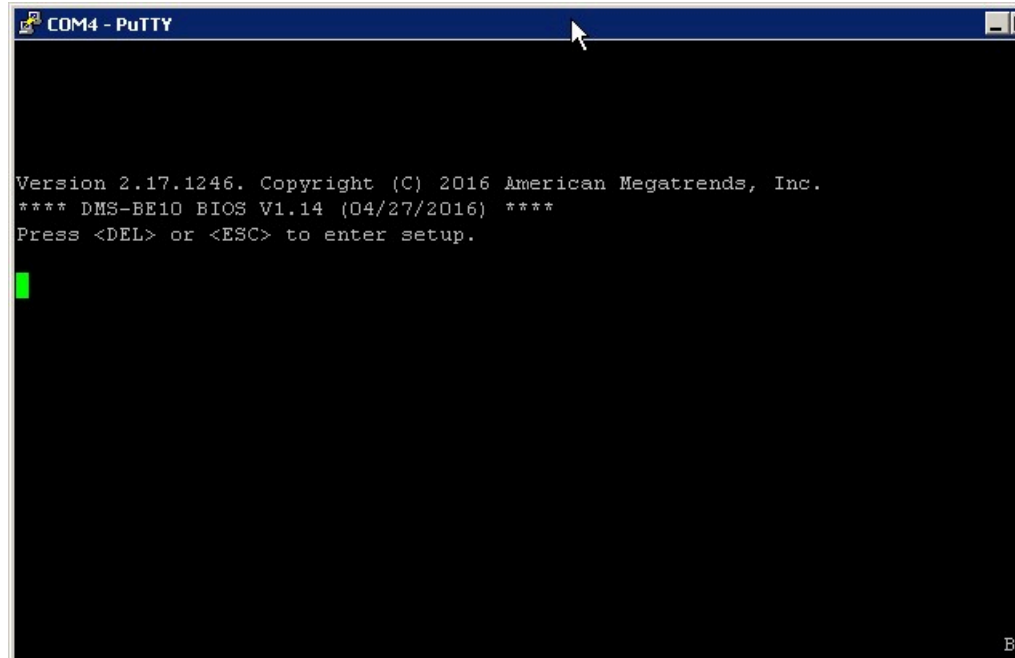

Figure 49: Reset STMIX via PuTTY

In the Save & Exit section go to "Realtek PXE" boot option and press Enter.

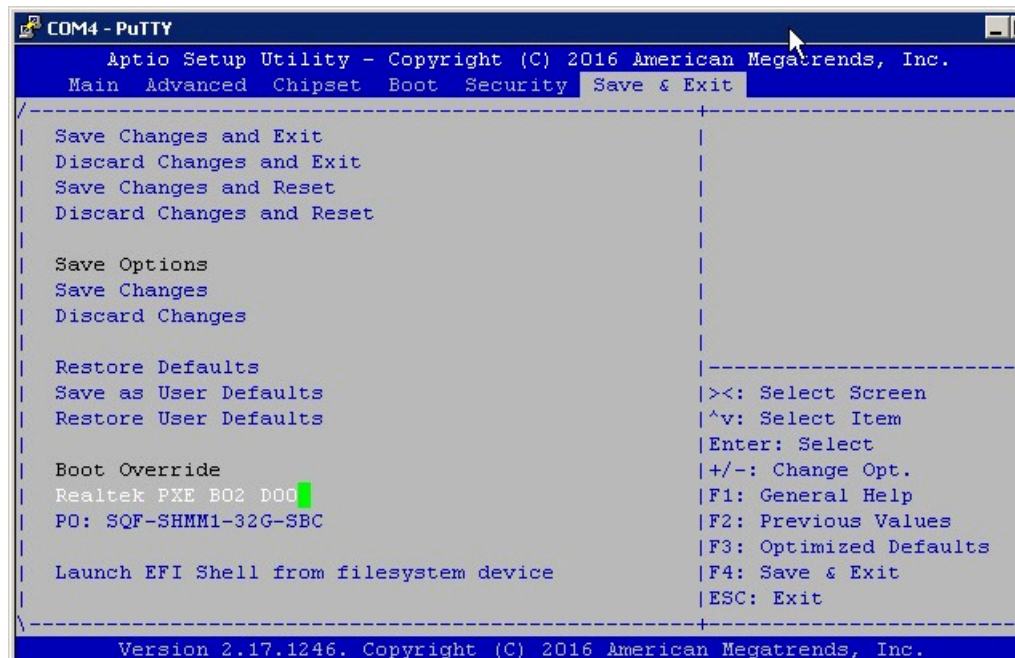

Figure 50: STMIX boot

NOTICE: If there is no option for "Realtek PXE" boot, first enable it under **Chipset -> South Bridge -> Lan1 Option-ROM -> Enable -> Save**. Exit and start over.

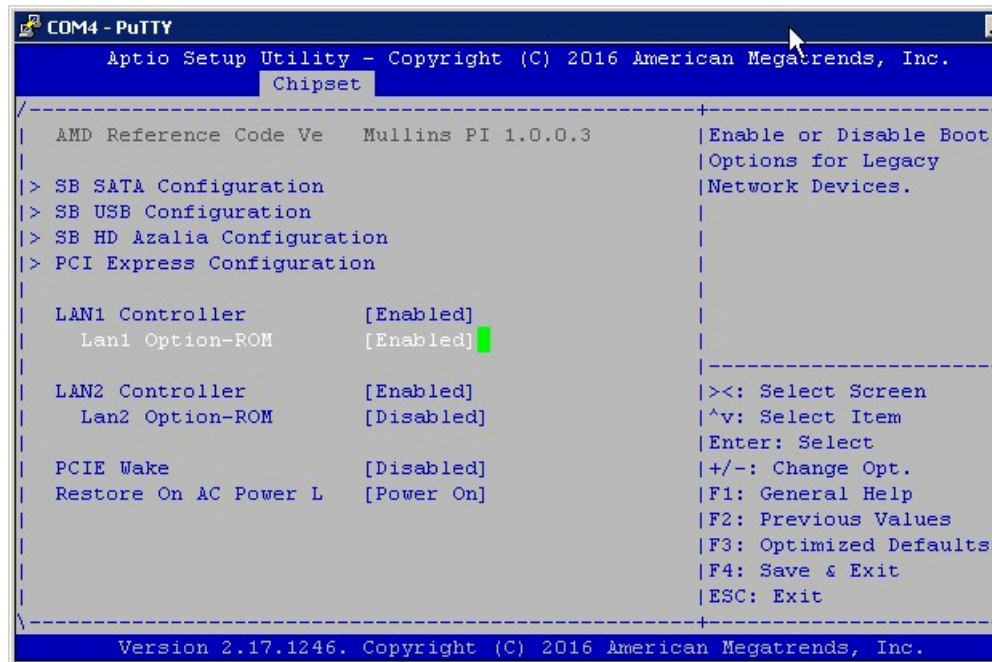

Figure 51: Enable Lan1 Option-ROM

3) Upon boot you will see STMIX PXE Boot in the terminal.

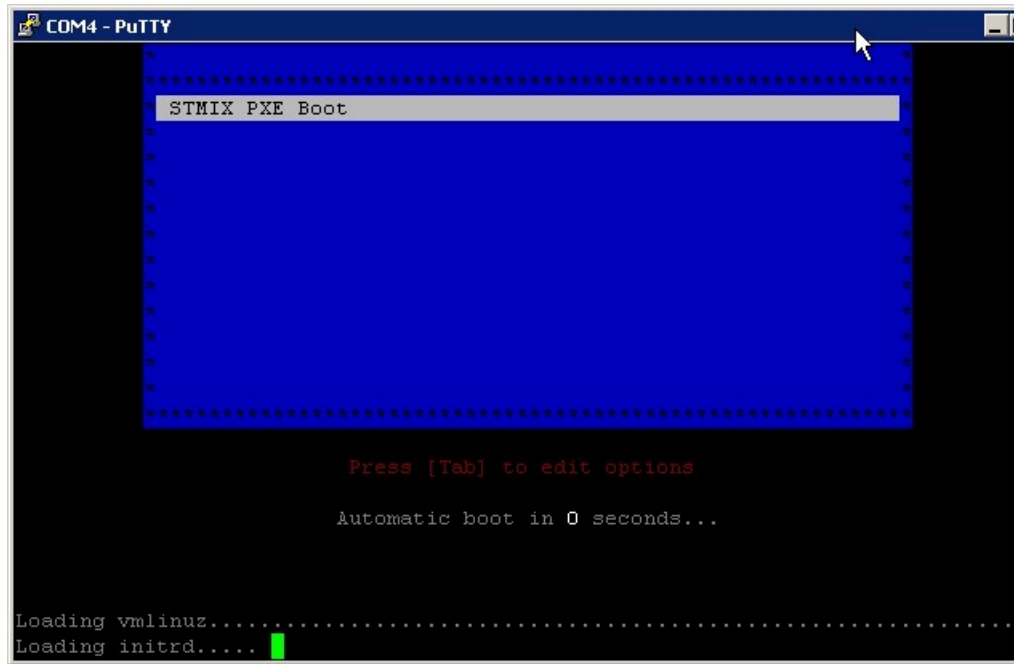

Figure 52: STMIX PXE Boot screen

You should now see in the dhcp/tftpd program popup messages with the allocated IP address and the files loading to STMIX.

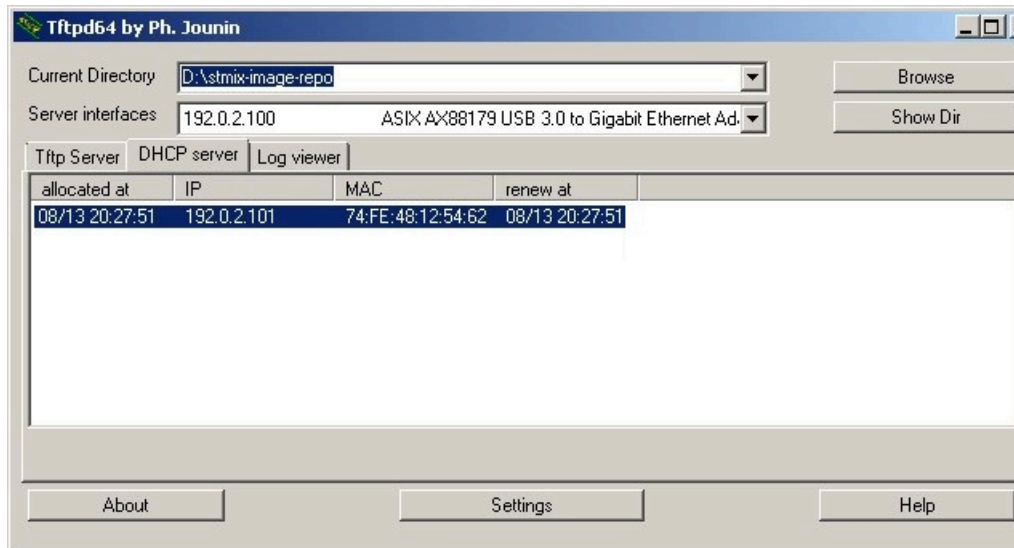

Figure 53: DHCP allocated address

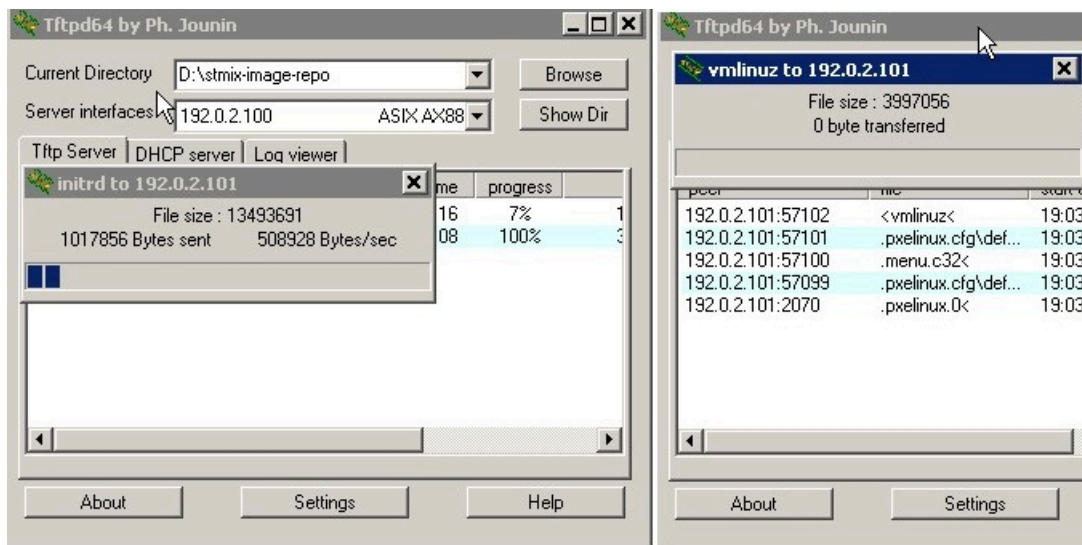

Figure 54: tftpd pop-ups

The output in the STMIX terminal should now show:

- Loading vmlinuz.....
- Loading initrd.....

The loader will be started and will fetch the image. Should see in terminal “Will fetch the following image: http://192.0.2.100/STMIX_JeOS_SLES11_SP4.x86_64-V10_R0.28.0.tar.gz”

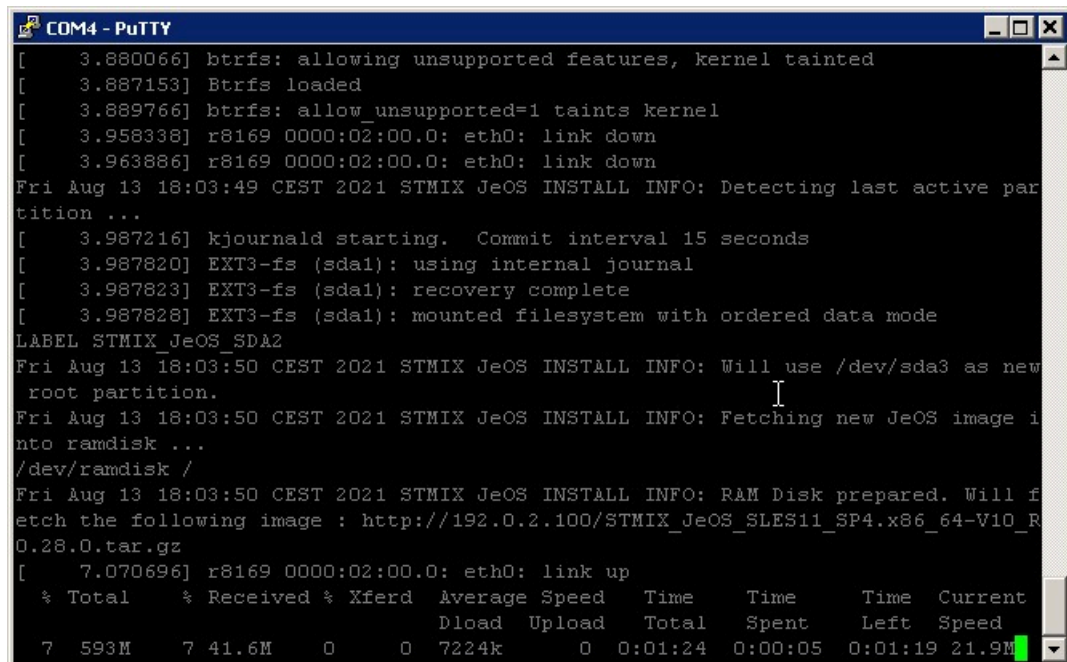

Figure 55: JeOS image fetch

The Fileserver will show in log screen the image and checksum loaded.

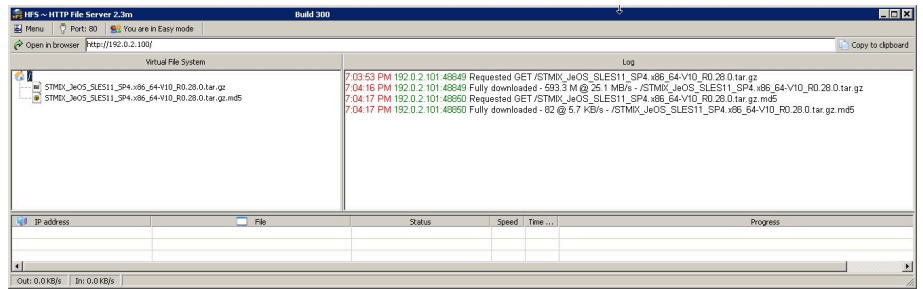

Figure 56: Image loaded

It will write the image to either sda2 or sda3, which will activate the partition and will reboot.

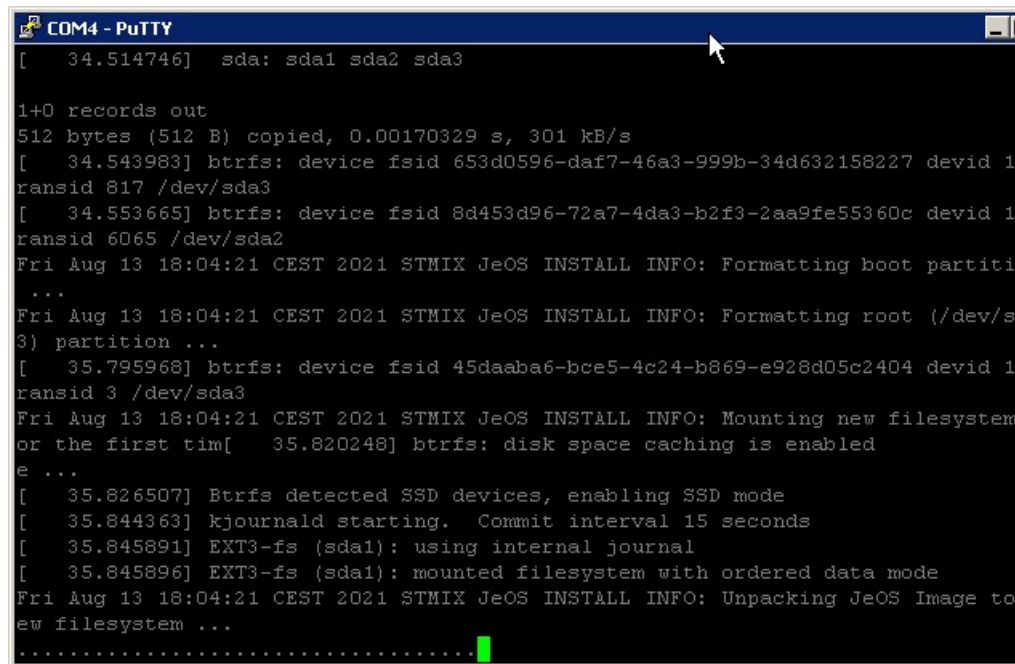

Figure 57: Image writing

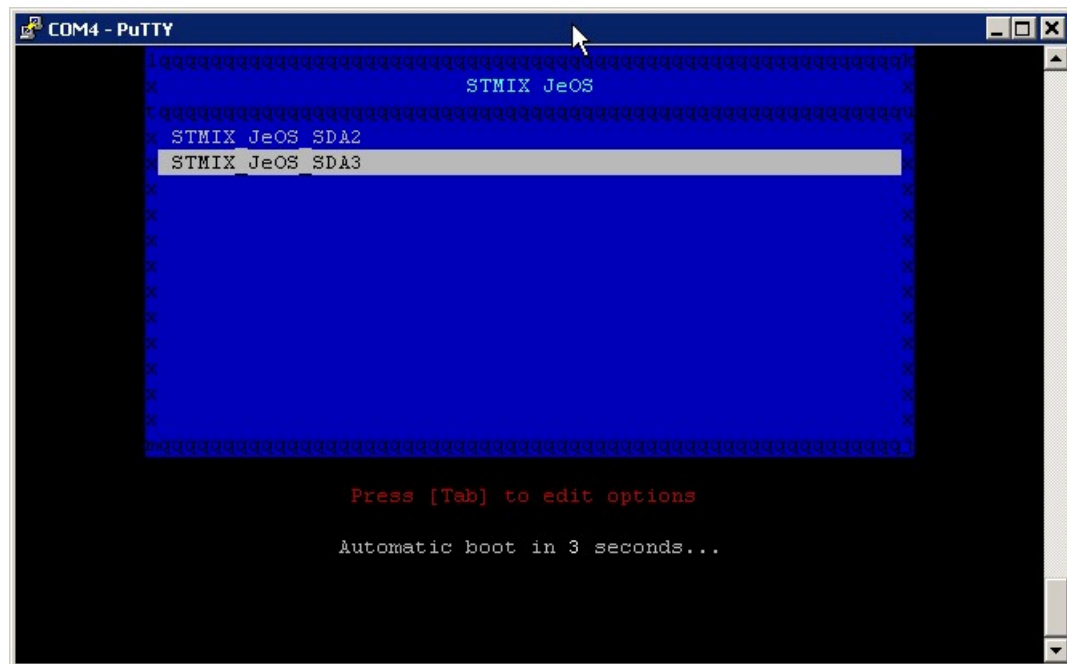

Figure 58: Automatically reboot

SDA2 will be written if SDA3 was the last known good partition that still booted.

SDA3 will be written if SDA2 was the last known good partition that still booted.

- 4) The STMIX should now boot from the just written sda2/sda3 which will be automatically activated by the flashing process (and become READY in RMX if configured).

NOTICE: When flashing more than one STMIX board in a row, before the next PXE boot process clear the DHCP Server cache (tftpd program's DHCP Server tab, right click on already used allocation and Delete). Otherwise, it will not allocate the IP address 192.0.2.101 again to another MAC address.

6.11 STMIY

The STMIY (Subscribe Trunk Module IP model Y) board is used as Common Gateway HG 3500

The STMIY peripheral board offers the following central and peripheral functions:

- Two high-speed Ethernet connections supporting 1Gbps Ethernet;
- Two USB 3.0 host ports: for maintenance purposes;
- Two system LED status indicators for showing up the status of the system;
- Reset button: enables quick system restart without the necessity of unplugging and plugging the board;
- Voice encoding functions (based on x86 CPU);

- Backplane interface (peripheral board function);
- USB slave interface for local console access (USB serial interface).

IMPORTANT: The STMIY is allowed to be hot plugged.

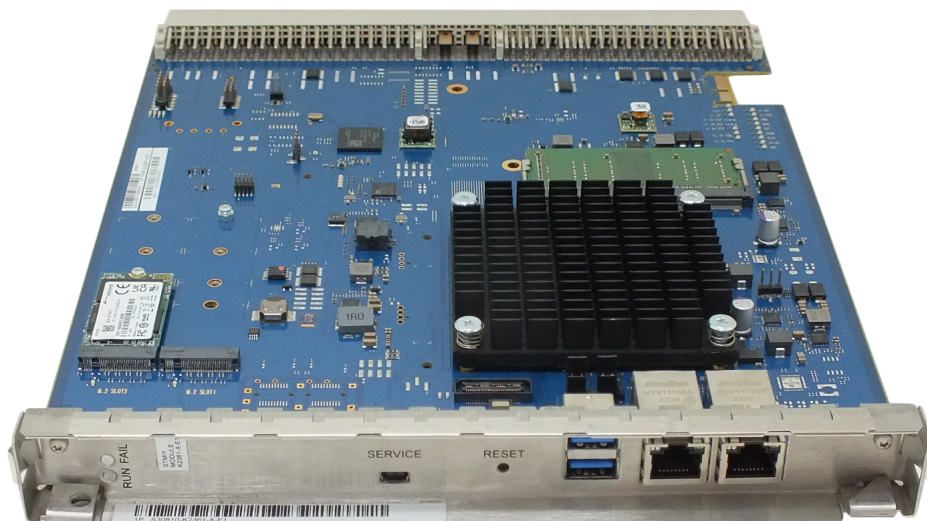

Figure 59: STMIY board

6.11.1 System Diagram

Figure shows a system diagram of the STMIY board.

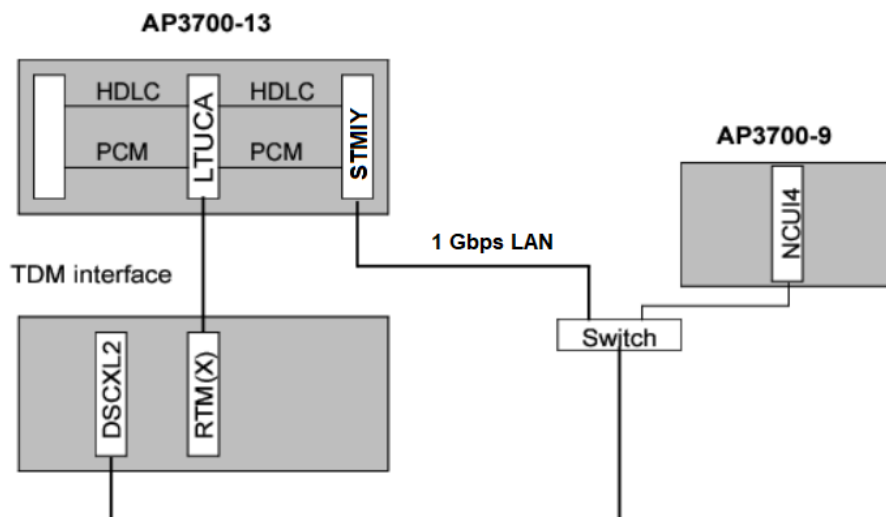

Figure 60: STMIY Board, System Diagram

6.11.2 Board Variants and Modules

Table 32: STMIY - Boards variants and modules

STMIY	Q2361-X (120-channel)
-------	-----------------------

The STMIY is the successor for the STMIX/STMI4 board (including STMI4 board equipped with PDMX module).

6.11.3 LED Displays and Interfaces

Following are the interfaces available on the frontal panel designed for service-related purposes:

- The board has one USB 2.0 Device port (Mini USB connector) for SERVICE console terminal;
- Additionally, the board has two USB 3.0 Host ports (Type A dual port connector) for maintenance purposes;
- Last but not least there is also a RESET button which can be used to provoke an immediate hardware reset.

Following is the list of LED displays for service-related purposes:

- Two RGB LED's for RUN/FAIL indications, showing up only GREEN/RED colors as usual;
- LAN1/LAN2 Ethernet Interface LED indications, see table below for details;

Table 33: RJ45 connector, ethernet Interface LED indications

Left LED	Right LED	Description
Steady orange light	Steady green light	Link 100 Mbps
Steady orange light	off	Link 10 Mbps
off	Steady green light	Link 1000 Mbps
off	flashing green	Activity 1000 Mbps
off	off	No link, no activity
flashing orange	flashing green	Activity 100 Mbps
flashing orange	off	Activity 10 Mbps



Figure 61: STMIY Board

6.11.4 Power Supply

STMIY uses only the +5V from backplane. From the +5V it is generated all STMIY internal lower voltages for a total power up to 17W per board. The +5V taken from backplane includes the staggered pre-charge contact, to allow hot plugging.

IMPORTANT: Although LUNA2 power supply is self-protecting, it is possible to operate maximum three STMIY boards parallel with one LUNA2 power supply.

6.11.5 Restrictions

Standby board HG 3500 and **QDC** is supported (from V8R1).

Features not supported:

- LW loading via (HDLC) backplane (only loading over Assistant GW manager is supported)
- WAML
- G.722, G.723 and OPUS codecs
- SNMP Call Statistic (RG2500 private MIB anno 1998)
- QDC (Quality Data Collection)
- H323 trunking (exception Xpressions connectivity is supported)
- SIP load balancer service (only on SoftGate)
- Rpcap and Assistant IP tracer support.
- FIPS 140-2
- AP1120 (vHFA has no FMoIP support)
- Assistant HBR HG3550M Backup Sets from STMI2/4 are not compatible with STMI3 (and vice versa). Means that existing backup sets (e. g. containing SPE certificates, SIP Trunk Profile configurations, etc.) cannot

Boards

How to reset a STMIY board

be restored on STMIX. Hence this restriction has further effect on "Standby HG3500" feature (see IP Solutions for further details).

IMPORTANT: Starting with V10R0 the support for STMI2 will not be offered anymore. The replacement for STMI2 is STMIX/STMIY.

6.12 How to reset a STMIY board

6.12.1 General description

The STMIY can be re-flashed in case the board is not booting or not becoming Ready Status in RMX.

The process can also be used to factory reset the STMIY HW board.

In comparison to STMIX for STMIY an USB Stick, as for OpenScape 4000 Installation, will be used.

Starting with Version 11 R1.26 Platform HotFix 1 the function is supported.

Perform the following steps:

- Create V11R1.26 USB Stick and copy the PLT HF V11R1.26.1 in the Hotfixes folder

Using Windows browse the Stick and unpack the <USB_Root>/EFI.zip archive to the <USB_Root>/EFI folder

After this operation there should be a <USB_Root>/EFI/boot folder present

- Using a OS4K system which already has PLT HF V11R1.26.1 installed and copy the following script file /opt/yaps/script/stmiy-reflash.sh to the USB Stick inside Hotfixes folder
- Connect the serial cable and connect to the serial port of STMIY

NOTICE:

If one has already used the serial for EcoServer or STMIX then the same works also for STMIY, i.e. same drivers.

- Insert the USB Stick into the STMIY card and reset using the reset button.
- The STMIY card is designed to boot first from USB Stick if the Stick is properly prepared so in this case the card boots from the prepared stick.
- After boot finishes one gets a linux login prompt to the so called "MiniLinux" of the OS4K SW Installation.

At this step login with "root" and password "hicom".

- Then call the following commands to mount the stick and launch the STMIY reflash procedure:

```
mount /dev/sdb1 /mnt
```

```
bash /mnt/Hotfixes/stmiy-reflash.sh
```

This procedure will take up to 5 minutes and will re-write **all** partitions.

At the end the output will ask the user to remove the USB Stick and then call the command "reboot" to restart the board.

NOTICE:

The board will reboot and then boot normally but then reboot once more automatically, so it will be a double-reboot.

This takes less than 2 minutes to complete.

Afterwards the board will get ready.

6.13 TMANI

This section describes the functions and features of the Trunk Modul Analog Interface (TMANI) board.



CAUTION: For lightning protection see [Section 2.3, "Lightning Protection"](#)

6.13.1 Functional Description

The new analog trunk board for OpenScape 4000 with 8 analog Ports, TMANI, is a solution to replace the analog trunk board TM2LP and TMC16 in OpenScape 4000.

The board TMANI that will be used in OpenScape 4000 will be the same use in HiPath 3800, with the same layout and dimensions, only the Part number of the board will be different for HiPath 3800 and OpenScape 4000. To make the board usable in OpenScape 4000, changes will be made in the LW.

TMANI board will support following line protocols:

- HKZ: same Loop Start protocol supported by TM2LP for the entire world;
- DID Italy: DID protocol (Direct Inward Dial) supported by TM2LP for Italy;
- DID Belgium: DID protocol supported by TM2LP for Belgium;
- Ground for USA: Ground Start protocol supported by TMC16 for USA;
- Loop for USA: Loop Start protocol supported by TMC16 for USA;

Table 34: TMANI protocols

Protocol	TM2LP	TMC16	TMANI	TMANI-IM	TMANI-BRA
Loop Start HKZ	X		X	X	X
DID Italy	X		X	X	X
DID Belgium	X		X	X	X

Protocol	TM2LP	TMC16	TMANI	TMANI-IM	TMANI-BRA
Ground Start USA		X	X		
Loop Start USA		X	X	X	X

Beyond the existing features of these protocols, TMANI board will support the following features:

- Clip Detection (Calling Line Identification Presentation);
- Busy Tone Detection;
- Dial Tone Detection* in TMANI board, not in SIU board;
- DTMF Generation* in TMANI board, not in SIU board;
- DTMF Detection* in TMANI board, not in SIU board;

* The TMANI board will not need a SIU board to run

Table 35: TMANI features

Features	TM2LP + SIU	TMC16 + SIU	TMANI TMANI-IM TMANI-BRA
Clip Detection			X
Busy Tone Detection			X
Dial Tone Detection	X	X	X
DTMF Generation	X	X	X
DTMF Detection	X		X

The existing features will be kept, such as:

- Disconnection supervision for Ground/Loop Start trunks;
- Special ring and dial tone cadences for each country;
- Billing tone detectors (only for -X100 variant): 12kHz/16kHz (the 50Hz billing tone is not supported);
- DP dial (IWW).

6.13.2 Systems Supported

- Support with AP 3300, AP 3700, AP 3300 IP and AP 3700 IP
- No special card distribution rules, complies with the standard rules

6.13.3 Hardware Variants

- TMANI: S30810-Q2327-X100, with GEE, with ground start
- TMANI-IM: S30810-Q2327-X101, without GEE, without ground start

- TMANI-BRA: S30810-Q2327-X182, only for Brasil, without GEE, without ground start

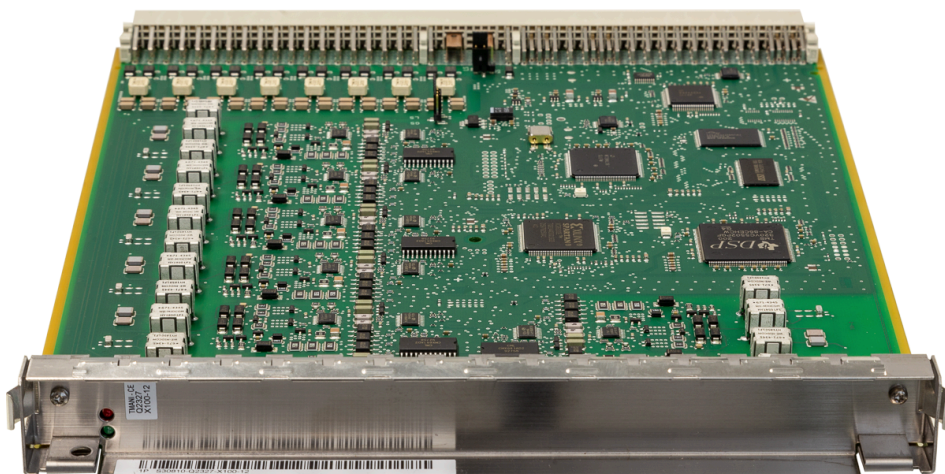

Figure 62: TMANI

6.13.4 Pin Assignment

Introduction

The TMANI board connects eight analog trunks to OpenScape 4000 using the loop start or ground start protocols.

IMPORTANT: According to U.S. and Canadian installation instructions, analog trunks must be connected over fuse elements in compliance with UL 497A or CSA C22.2 No. 226.

TMANI Front panel

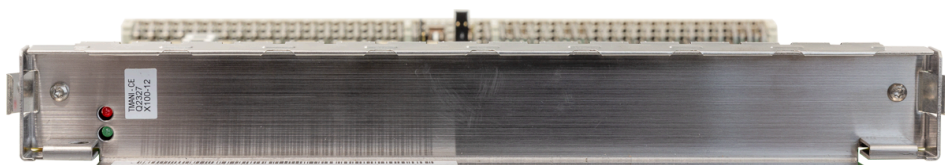

Figure 63: TMANI - Front Panel

LED statuses and their meanings

Table 36: TMANI - LED Statuses

Red LED	Green LED	Status	Action
Off	Off	Board not receiving power or not plugged in correctly. Board is out of order.	Check plug contact on board.

Boards

Red LED	Green LED	Status	Action
On	Off	Board is receiving power and board test is in progress. Board is defective if status remains unchanged (board test unsuccessful).	Replace the board.
		Loadware loading not successfully completed. Board is faulty.	Replace the board.
		Error detected on board. Board is deactivated (not applicable to errors detected by test loops).	Check whether the board was deactivated. If not, replace board.
Flashing	Off	Loadware is being loaded.	
Off	On	Board test completed successfully. Board is OK (idle state).	
Off	Flashing	At least one subscriber line circuit is activated.	

Jumper for ground start

The two jumpers marked with GS were placed on the board to satisfy security standards. The jumpers must be closed for countries that support the "Ground-Start" feature (the U.S. and Canada). The jumpers must remain open for other countries that support the "Loop-Start" feature.

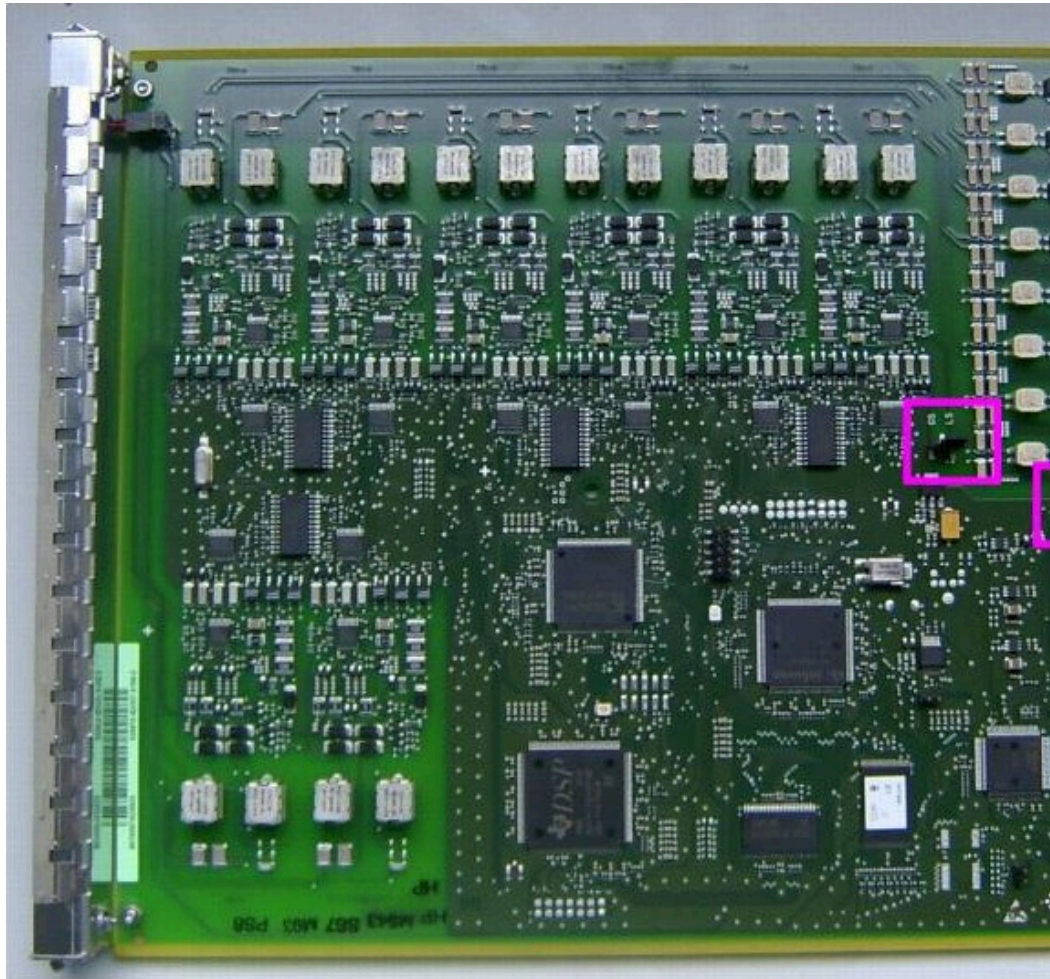

Figure 64: TMANI Jumper position

Cable and connector assignment

- For connecting to the SIVAPAC connector on the backplane: [Table 28](#)
- For connecting to the connector panels using RJ45 jacks: [Table 29](#)
- For U.S. only: For connecting to the connector panels with CHAMP jack: [Table 30](#)

Table 37: TMANI - SIVAPAC Connector Assignment on the Backplane

Pair	a-wire (Tip)	b-wire (Ring)	SIVAPAC connector	TMANI		MDFU-E	Notes
1	wht/blu		1	1a	Port 1	1a	
			23	1b		1b	
2	wht/ora		3	2a	Port 2	2a	

Boards

Pair	a-wire (Tip)	b-wire (Ring)	SIVAPAC connector	TMANI		MDFU-E	Notes
		ora/wht	4	2b		2b	
3	wht/grn		5	3a	Port 3	3a	
		grn/wht	6	3b		3b	
4	wht/brn		7	4a	Port 4	4a	
		brn/wht	8	4b		4b	
5	wht/grn		9	5a	Port 5	5a	
		grn/wht	10	5b		5b	
6	red/blu		11	6a	Port 6	6a	
		blu/red	12	6b		6b	
7	red/ora		13	7a	Port 7	7a	
		ora/red	14	7b		7b	
8	red/grn		15	8a	Port 8	8a	
		grn/red	16	8b		8b	
9	red/brn		17		Free		
		brn/red	18				
10	red/grn		19		Free		
		grn/red	20				
11	blk/blu		24		Free		

Pair	a-wire (Tip)	b-wire (Ring)	SIVAPAC connector	TMANI		MDFU-E	Notes
		blu/blk	25				
12	blk/ora		26		Free		
		ora/blk	27				
13	blk/grn		29		Free		
		grn/blk	30				
14	blk/brn		31		Free		
		brn/blk	32				
15	blk/grn		34		Free		
		grn/blk	35				
16	yel/blu		37		Free		
		blu/yel	38				

Table 38: TMANI - Connector Panel Assignment with RJ45 Jacks

RJ45 jack		TMANI	Notes
No.	Pin		
1	4	1a	
	5	1b	
2	4	2a	
	5	2b	
3	4	3a	
	5	3b	
4	4	4a	
	5	4b	

Boards

RJ45 jack		TMANI	Notes
No.	Pin		
5	4	5a	
	5	5b	
6	4	6a	
	5	6b	
7	4	7a	
	5	7b	
8	4	8a	
	5	8b	
9	4		Free
	5		
10	4		Free
	5		
11	4		Free
	5		
12	4		Free
	5		
13	4		Free
	5		
14	4		Free
	5		
15	4		Free
	5		
16	4		Free
	5		
17	4		Free
	5		
18	4		Free
	5		

RJ45 jack		TMANI	Notes
No.	Pin		
19	4		Free
	5		
20	4		Free
	5		
21	4		Free
	5		
22	4		Free
	5		
23	4		Free
	5		
24	4		Free
	5		

Table 39: TMANI - Connector Panel Assignment with CHAMP Jack (for U.S. only)

CHAMP jack	TMANI			Notes
1	1a	1 Ring	Port 1	
26	1b	1 Tip		
2	2a	2 Ring	Port 2	
27	2b	2 Tip		
3	3a	3 Ring	Port 3	
28	3b	3 Tip		
4	4a	4 Ring	Port 4	
29	4b	4 Tip		
5	5a	5 Ring	Port 5	
30	5b	5 Tip		
6	6a	6 Ring	Port 6	
31	6b	6 Tip		
7	7a	7 Ring	Port 7	

CHAMP jack	TMANI			Notes
32	7b	7 Tip		
8	8a	8 Ring	Port 8	
33	8b	8 Tip		
9			Free	
34				
10			Free	
35				
11			Free	
36				
12			Free	
37				
13			Free	
38				
14			Free	
39				
15			Free	
40				
16			Free	
41				

6.13.5 Example for configuring the TMANI Board (Germany)

IMPORTANT: Configuring the TMANI board for other countries please notice the specific ptime values for each country see [Section 6.9.6, "PTIMES"](#).

```
ADD-BCSU: MTYPE=PER, LTG=1, LTU=2, SLOT=79, PARTNO="Q2327-
X100", FCTID=0, LWVAR="0", HWYBDL=A, ALARMNO=0;
ADD-BUEND: TGRP=40, NAME="HKZ-TMANI
", NO=8, TRACENO=0, ACDTHRH=*, PRIONO=1, TDDRFLAG=ON, GDTRRULE=0, ACDPMGRP=
ADD-COSSU: NEWCOS=8, INFO="TMANI"; CHANGE-
COSSU: TYPE=COS, COS=8, AVCE=TA&TSUID&TNOTCR&TTT;
CHANGE-COSSU: TYPE=COS, COS=8, AFAX=NOCO&NOTIE;
CHANGE-COSSU: TYPE=COS, COS=8, ADTE=NOCO&NOTIE;
```

```

CHANGE-COSSU:TYPE=LCOSV,LCOSV=1,COPIN=0; CHANGE-
COSSU:TYPE=LCOSV,LCOSV=1,INFO="LCR ATTENDANT FOR VOICE";
ADD-
COP:COPNO=40,PAR=DTMF&SFRM&RLSA&BR64&TDED&NO1A&DITW&TIM1&NSDL&IDP
CHANGE-COP:COPNO=40,COPTYPE=COPADD,DEV=INDEP,INFO="TMANI-
DTMF";
ADD-COT:COTNO=40,PAR=XFER&CHRT&NTON; CHANGE-
COT:COTNO=40,COTTYPE=COTADD,DEV=INDEP,INFO="TMANI-DTMF";
ADD-LODR:ODR=99,CMD=ECHO,FIELD=2; ADD-LODR:ODR=99,CMD=END;
ADD-LODR:ODR=99,INFO="NQ A2 OPEN";
COPY-PTIME:INIBLOCK=119,TBLK=13;
ADD-
TACSU:PEN=1-2-79-0,COTNO=40,COPNO=40,DPLN=0,ITR=0,COS=8,LCOSV=1,L
",DITIDX=0,TRTBL=GDTR,RULEIDX=0,INS=Y,DEVTYPE=TC,DEV=TMANIMSG,MF
DTMF,DIALVAR=0-0,COEX=0;
ADD-RICHT:MODE=LRTENNEW,LRTE=40,LSVC=VCE,NAME="HKZ-TMANI
",TGRP=40,DNNO=1,REROUT=NO,DTMFTEXT="",ROUTATT=NO,EMCYRTT=NO,INF
ADD-
LDAT:LROUTE=40,LSVC=VCE,LVAL=1,TGRP=40,ODR=99,LAUTH=1,CARRIER=1,Z
ADD-WABE:CD=555,DAR=CO,CHECK=N;
ADD-LDPLN:LRCRCONF=LCRPATT,DIPLNUM=0,LDP=555-
X,LROUTE=40,LAUTH=1,PINDP=N;

```

6.13.6 PTIMES

Table 40: Ptime values for countries

Country	Input impedance	Balance Impedance	Attenuation A-D	Attenuation D-A	COEX	P12	P14	P5	P6	P 11	P13
Algeria	220+820//115n	220+820//115n	-7,9	-2,9	5	16	2	76	97	6	0
	220+820//115n	220+820//115n	-4,9		5	16	1				
Argentina	600	600	-6	-1	0	0	0	12	65	6	0
Australia	220+820//115n	220+820//115n	-6	1	5	16	38	113	65	6	0
Austria	270+750//150n	270+750//150n	-6	-1	4	16	0	140	97	0	0
Bahrain	370+620//310n	300+1000//220n	-8	2	14	0	14	76	97	6	0
			-5	-1			23				
	370+620//310n	600	-8	2	13	0	14	76	97	6	0
			-5	-1			23				
Belarus	220+820//115n	220+820//115n	-5	-2	5	16	22	76	97	6	0
			-7	0			16				
Belgium	270+750//150n	270+750//150n	-6	-1	4	16	0	140	97	0	0
Bangladesh	600	600	-5	-2	0	0	22	76	97	6	0

Boards

Country	Input impedance	Balance Impedance	Attenuation A-D	Attenuation D-A	COEX	P12	P14	P5	P6	P 11	P13
			-7	0			16				
			0	-7			34				
Bolivia	220+820//115n	220+820//115n	-5	-2	5	16	22	76	97	6	0
			-7	0			16				
	900	190+1400//105n	-6	-1	8	0	0				
	900	400+590//50n	-6	-1	7	0	0				
Brazil	900	900	-6	-1	3	16	0	12	65	6	0
Bulgaria	270+750//150n	270+750//150n	-6	-1	4	16	0	140	97	0	0
			-4	-3			27				
Cameroon	600	400+700//200n	-6	-1	1	0	0	76	97	6	0
			-5	-2			22				
			0	-7			34				
Chile	600	400+700//200n	-5	-2	1	0	22	76	97	6	0
			-6	-1			0				
			0	-7			34				
China	200+680//100n	200+680//100n	-6	-1	12	16	0	12	65	1	0
			0	-3,5			35				
Colombia	220+820//115n	220+820//115n	-5	-2	5	16	22	76	97	6	0
			-7	0			16				
Costa Rica	600	100+820//68n	-5,8	-1,3	5	0	19	76	97	6	0
	600	400+700//200n	-5	-2	1	0	22				
			-6	-1			0				
			0	-7			34				
Cote D'Ivoire	600	400+700//200n	-5	-2	1	0	22	76	97	6	0
			-6	-1			0				
			0	-7			34				
Croatia	270+750//150n	270+750//150n	-6	-1	4	16	0	140	97	0	0
			-4	-3			27				

Country	Input impedance	Balance Impedance	Attenuation A-D	Attenuation D-A	COEX	P12	P14	P5	P6	P 11	P13
Czech Republic	270+750//150n	270+750//150n	-6	-1	4	16	0	76	97	6	0
Denmark	270+750//150n	270+750//150n	-6	-1	4	16	0	140	97	0	0
Ecuador	220+820//115n	220+820//115n	-5	-2	5	16	22	76	97	6	0
			-7	0			16				
Egypt											
Egypt	220+820//115n	220+820//115n	-5	-2	5	16	22	76	97	6	0
			-7	0			16				
El Salvador	600	100+820//68n	-7	0	5	0	16	76	97	6	0
			-5	-2			22				
			0	-7			34				
			-5,8	-1,3			19				
	600	400+700//200n	-5	-2	1	0	22				
			-6	-1			0				
			0	-7			34				
	Estonia	270+750//150n	270+750//150n	-6	-1	4	16	0	140	97	0
-4				-3	27						
Europe	270+750//150n	270+750//150n	-6	-1	4	16	0	140	97	0	0
Finland	270+750//150n	270+750//150n	-6	-1	4	16	0	140	97	0	0
France	270+750//150n	270+750//150n	-6	-1	4	16	0	140	97	0	0
Ghana	600	400+700//200n	-6	-1	1	0	0	76	97	6	0
			-5	-2			22				
			0	-7			34				
Greece	270+750//150n	270+750//150n	-6	-1	4	16	0	140	97	0	0
Guatemala											
Guatemala	600	100+820//68n	-5,8	-1,3	5	0	19	76	97	6	0
			-7	0			16				
			-5	-2			22				
			0	-7			34				

Boards

Country	Input impedance	Balance Impedance	Attenuation A-D	Attenuation D-A	COEX	P12	P14	P5	P6	P 11	P13
Hongkong	600	600	-7	0	0	0	16	12	65	6	0
Honduras	220+820//115n	220+820//115n	-5	-2	5	16	22	76	97	6	0
			-7	0			16				
Hungary	270+750//150n	270+750//150n	-6	-1	4	16	0	140	97	6	0
Indonesia	600	600	-7	0	0	0	16	12	65	6	0
India	600	600	-7	-0,5	0	0	37	12	65	6	0
			-9	2			12				
Ireland	270+750//150n	270+750//150n	-6	-1	4	16	0	140	97	6	0
Iran	220+820//115n	220+820//115n	-5	-2	5	16	22	76	97	6	0
			-7	0			16				
Israel	220+820//115n	220+820//115n	-5	-2	5	16	22	76	97	6	0
			-7	0			16				
Italy	270+750//150n	270+750//150n	-6	-1	4	16	0	140	97	0	0
Japan	600	600	-4	-3	0	0	27	76	97	6	0
			-3	-4			30				
			-7	0			16				
			-5	-2			22				
Jordan	600	400+700//200n	-6	-1	1	0	0	76	97	6	0
			-5	-2			22				
			0	-7			34				
Kenya	600	400+700//200n	-5	-2	1	0	22	76	97	6	0
			-6	-1			0				
			0	-7			34				
Kuwait	220+820//115n	220+820//115n	-5	-2	5	16	22	76	97	6	0
			-7	0			16				
Latvia	270+750//150n	270+750//150n	-6	-1	4	16	0	140	97	0	0
			-4	-3			27				
Libyan Arab Jamahiriya	220+820//115n	220+820//115n	-5	-2	5	16	22	76	97	6	0
			-7	0			16				

Country	Input impedance	Balance Impedance	Attenuation A-D	Attenuation D-A	COEX	P12	P14	P5	P6	P 11	P13
Liberia	220+820//115n	220+820//115n	-5	-2	5	16	22	76	97	6	0
			-7	0			16				
Lithuania	270+750//150n	270+750//150n	-6	-1	4	16	0	140	97	0	0
			-4	-3			27				
Luxembourg	270+750//150n	270+750//150n	-6	-1	4	16	0	140	97	0	0
			-4	-3			27				
Malaysia	600	400+700//200n	-7	-0,5	1	0	37	5	65	1	0
Morocco	270+750//150n	270+750//150n	-6	-1	4	16	0	76	97	6	0
Macedonia	270+750//150n	270+750//150n	-6	-1	4	16	0	140	97	0	0
			-4	-3			27				
Mexico	600	220+820//115n	-5,8	-1,3	3	0	19	76	97	6	0
Myanmar	600	600	-5	-2	0	0	22	76	97	6	0
			-7	0			16				
			0	-7			34				
Netherlands	270+750//150n	270+750//150n	-6	-1	4	16	0	140	97	0	0
			-4	-3			27				
			0	-7			34				
Nigeria	220+820//115n	220+820//115n	-5	-2	5	16	22	76	97	6	0
			-7	0			16				
Nicaragua	600	100+820//68n	-7	0	5	0	16	76	97	6	0
			-5	-2			22				
			0	-7			34				
	600	400+700//200n	-5	-2	1	0	22	76	97	6	0
			-6	-1			0				
			0	-7			34				
Norway	270+750//150n	270+750//150n	-6	-1	4	16	0	140	97	0	0
New Zealand	370+620//310nF	370+620//310nF	-6	-0,5	6	16	17	76	97	6	0
Oman	220+820//115n	220+820//115n	-5	-2	5	16	22	76	97	6	0
			-7	0			16				

Boards

Country	Input impedance	Balance Impedance	Attenuation A-D	Attenuation D-A	COEX	P12	P14	P5	P6	P 11	P13
Pakistan	600	400+700//200n	-7	-0,5	1	0	37	5	65	6	0
Panama	600	100+820//68n	-7	0	5	0	16	76	97	6	0
			-5	-2			22				
			0	-7			34				
			-5,8	-1,3			19				
	600	400+700//200n	-5	-2	1	0	22				
			-6	-1			0				
0			-7	34							
Paraguay	220+820//115n	220+820//115n	-5	-2	5	16	22	76	97	6	0
			-7	0			16				
Philippines	900	900	-7	0	3	16	16	5	65	6	0
			-5	-2			22				
Poland	270+750//150n	270+750//150n	-6	-1	4	16	0	140	97	0	0
Portugal	270+750//150n	270+750//150n	-6	-1	4	16	0	140	97	0	0
Peru	220+820//115n	220+820//115n	-5	-2	5	16	22	76	97	6	0
			-7	0			16				
	900	190+1400//105n	-6	-1	8	0	0				
	900	400+590//50n	-6	-1	7	0	0				
Qatar	220+820//115n	220+820//115n	-7	0	5	16	16	76	97	6	0
			-5	-2			22				
Republic of Korea	600	600	-7	0	0	0	16	12	65	11	0
			-4	-3			27				
Republic of South Africa	220+820//115n	220+820//115n	-6	-1	5	16	0	12	65	8	0
Romania	270+750//150n	270+750//150n	-6	-1	4	16	0	140	97	0	0
			-4	-3			27				
Russian Federation	150+510//47nF (600+2,16uF)	150+510//47nF	-6	-1	2	32	0	76	97	6	0
			-3,5	-3,5			29				
Rwanda	600	400+700//200n	-5	-2	1	0	22	76	97	6	0

Country	Input impedance	Balance Impedance	Attenuation A-D	Attenuation D-A	COEX	P12	P14	P5	P6	P 11	P13
			-6	-1			0				
			0	-7			34				
Saudi Arabia	220+820//115n	220+820//115n	-7	0	5	16	16	76	97	6	0
			-5	-2			22				
Senegal	220+820//115n	220+820//115n	-7,9	2,9	5	16	2	76	97	6	0
			-4,9	-5,9			1				
Singapore	600	400+700//200n	-6	-1	1	0	0	140	97	1	0
Slovenia	270+750//150n	270+750//150n	-6	-1	4	16	0	140	97	0	0
			-4	-3			27				
Spain	270+750//150n	270+750//150n	-6	-1	4	16	0	140	97	0	0
Slovakia	270+750//150n	270+750//150n	-6	-1	4	16	0	140	97	0	0
			-4	-3			27				
			0	-7			34				
Sudan	220+820//115n	220+820//115n	-5	-2	5	16	22	76	97	6	0
			-7	0			16				
Switzerland	270+750//150n	270+750//150n	-6	-1	4	16	0	140	97	0	0
			-4	-3			27				
Syrian Arab Republic	220+820//115n	220+820//115n	-5	-2	5	16	22	76	97	6	0
			-7	0			16				
Thailand	600	600	-6	-1	0	0	0	5	65	6	0
Turkey	600	600	-6	-1	0	0	0	140	97	0	0
Tunisia	270+750//150n	270+750//150n	-6	-1	4	16	0	140	97	0	0
			-4	-3			27				
United Arab Emirates	220+820//115n	220+820//115n	-5	-2	5	16	22	76	97	6	0
			-7	0			16				
United Republic Tanzania	600	400+700//200n	-5	-2	1	0	22	76	97	6	0
			-6	-1			0				
			0	-7			34				
Uruguay	220+820//115n	220+820//115n	-5	-2	5	16	22	76	97	6	0

Boards

Country	Input impedance	Balance Impedance	Attenuation A-D	Attenuation D-A	COEX	P12	P14	P5	P6	P 11	P13
			-7	0			16				
United Kingdom	270+750//150n	270+750//150n	-6	-1	4	16	0	140	97	0	0
United States of America	600	600	-3	3	0	0	5	76	97	6	0
Venezuela	220+820//115n	220+820//115n	-5	-2	5	16	22	76	97	6	0
			-7	0			16				
			-5,8	-1,3			19				
Viet Nam	200+680//100n	100+820//68n	-4	-3	2	16	27	12	65	7	0
			-3	-4			30				
			0	-3,5			35				
			0	-7			34				
	200+680//100n	200+680//100n	0	-3,5	12	16	35				
	200+680//100n	600	-3	-4	1	16	30				
	600	100+820//68n	-4	-3	5	0	27				
	600	200+680//100n	0	-3,5	4	0	35				
	600	600	-7	0	0	0	16				
			-5	-2			22				
			-4	-3			27				
			-3	-4			30				
			0	-3,5			35				
0	-7	34									
Yemen	370+620//310n	300+1000//220n	-8	2	14	0	14	76	97	6	0
			-5	-1			23				
	370+620//310n	600	-8	2	13	0	14				
			-5	-1			23				
Zimbabwe	600	400+700//200n	-5	-2	1	0	22	76	97	6	0
			-6	-1			0				
			0	-7			34				

SL = Short Line

LL = Long Line

6.14 TMEW2

The trunk module for E&M world (TMEW2) board provides four tie-line connections (4-wire type I E&M signaling) between the OpenScape4000 and other OpenScape 4000 systems or private branch exchanges (PBXs).



CAUTION: For lightning protection see [Section 2.3, "Lightning Protection"](#).

E&M leads are used for signalling between PBXs at two different locations. Signalling between TIE trunks is performed by the E (for Ear or for rEceive) and M (for Mouth or transMit) leads.

The M lead transmits a ground, open or -48V signal. The circuitry on the board converts the logic signal (+5V OR 0V) from the microprocessor through the SICOFI latch outputs. Conversely the E-lead which connects to the remote PBX M lead, receives the -48V, open or ground levels and converts them to +5/0 voltage levels. The signalling protocol is system software programmed as Delay Dial, Wink Start (most common choice), Immediate Start, and so on. The on-board loadware microprocessor handles the E & M signalling protocol through the SICOFI.

For standard Type 1 signalling, when E/M is connected to signalling equipment, an offhook M lead is -48V, while onhook is ground. When two TMEW2s are connected back-to-back (M lead to E lead), TYPE 1A signalling should be selected where offhook M lead is ground and onhook is OPEN.

The order number for TMEW2 is S30810-Q2327-X182.

6.14.1 Functions and Features for Target Countries

The TMEW2 has the following analog trunk interface functions:

- TYPE 1, 2, 1A, DC5 E & M signalling and Low level supervision
- Programmable selection of type of Signalling methods
- Programmable transmit and receive gains
- Separate transmit and receive voice pairs - 4 wires
- Optional 2 wires voice path is available for future target countries application

The TMEW2 has the following system features:

- U-law or A-law companding of the voice signal
- Access to PCM highways with flexible time slot channel selection
- HDLC link to communicate with the PBXs switching unit

6.14.2 Description of Interfaces

There are three main functional boundaries to the TMEW2: board

- Analog E & M trunk interface
- Channel and voice-path interface

- Common control interface

6.14.3 LED Indications

The front panel of the TMEW2 board features two LEDs (red and green). [Table 32](#) lists the LED indications during the TMEW2 board startup procedure.

Table 41: TMEW/TMEMUS Boards, LED Indications

Red LED	Green LED	Indication
On	Off	Power supply available
Flashing	Off	Software is being loaded to the board.
On	Off	The board is defective or out-of-service.
Off	On	The board is operational and all channels are assigned.
Off	Flashing	The board is operational and one or more of the channels are assigned.

6.14.4 Configuring the Board

AMO BCSU must be modified so that the action CHA-BCSU (change) can be used to reconfigure boards of different types. When replacing a TMEW board with a TMEW2 board, configure the board as follows:

- 1) Turn off the lines on the board.
- 2) Turn off the board.
- 3) Reconfigure the board.
- 4) Assign the expanded line data to the lines by means of the index (CIRCIDX).
- 5) Turn on the lines and the board.

Table 42: TMEW2, Nominal Loss and Overload Point of Half Connections

	Transmit Path A->D (Li or PE)			Receive Path D->A (Lo or PA)			
Gain Index	Normal Loss (dB)	Input Relative Level at T1/R1 (dBr)	Input Overload Point to Produce D.F.S (dBr)	Normal Loss (dB)	Output Relative level at T/R (dBr)	Output Overload Point Produced by D.F.S. (dBr)	Countries
0 *)	-3.5	-3.5	-0.5	+3.5	-3.5	-0.5	A-law Italy Finland Austria France Greece Sweden
1	0	0	+3	+6	-6	-3	U.S.A. **) - U-law'
2	-1.5	-1.5	+1.5	+1.5	-1.5	+1.5	Australia***) -A-law
3	-2.5	-2.5	+0.5	+4.5	-4.5	-1.5	Germany - A-law
4	+0.5	+0.5	+3.5	+4.5	-4.5	-1.5	U.K. -'A-law'
*)	Default gain index used before TMEW2 board is configured to any specific countries						
**)	Gain index reserved for the USA, but TMEW2 is not sold to the U.S.A. as stated in TMEW2 A30 document						
***)	Gain index reserved for Australia, but TMEW2 will not be used in Australia						

Weighted Noise (I-ETS 300005)

Table 34 lists the weighted noise level of the TMEW2 board.

Table 43: Weighted noise level

Connection Type Noise Level (dBm0p)	
Analog-to-Digital	66

Connection Type Noise Level (dBm0p)	
Digital-to-Analog	75

Table 35 lists the transverse conversion loss (TCL) of the TMEW2 board.

Table 44: Transverse conversion loss

Frequency (Hz)	Min (dB)
300 - 3400	46

6.14.5 Connector Pin Assignments

Table 36 lists the upper connector pin assignments of the TMEW2 board.

Table 45: Upper connector pin assignment

Pin #	Signal Name	Pin #	Signal Name	Pin #	Signal Name
41	NC	21	+5V	01	T1-1
42	NC	22	GND	02	+12V
43	NC	23	R1-1	03	T1-2
44	NC	24	E(1)/E(2)-3	04	R1-2
45	NC	25	M(1)/SG-3	05	T1-3
46	NC	26	E(1)/E(2)-4	06	R1-3
47	NC	27	M(1)/SG-4	07	T1-4
48	NC	28	GND	08	R1-4
49	NC	29	S3AN(LL)/M(2)-1	09	T-1
50	NC	30	S3AB(LL)/SB(2)-1	10	R-1
51	NC	31	S3AN(LL)/M(2)-2	11	T-2
52	NC	32	S3AB(LL)/SB(2)-2	12	R-2
53	NC	33	GND	13	T-3
54	NC	34	S3AN(LL)/M(2)-3	14	R-3
55	NC	35	S3AB(LL)/SB(2)-3	15	T-4
56	NC	36	-5V	16	R-4
57	NC	37	S3AN(LL)/M(2)-4	17	E(1)/E(2)-1
58	NC	38	S3AB(LL)/SB(2)-4	18	M(1)/SG-1

Pin #	Signal Name	Pin #	Signal Name	Pin #	Signal Name
59	NC	39	GND	19	E(1)/E(2)-2
60	NC	40	+5V	20	M(1)/SG-2

Table 37 lists the middle connector pin assignments of the TMEW2 board.

Table 46: Middle connector pin assignment

Pin #	Signal Name
1	GND
2	+5VL

Table 38 lists the lower connector pin assignments of the TMEW2 board.

Table 47: Lower connector pin assignment

Pin #	Signal Name	Pin #	Signal Name	Pin #	Signal Name
41	NC	21	+5V	01	RING
42	NC	22	GND	02	+12V
43	NC	23	GND	03	-48V
44	NC	24	DIAL1	04	-60V
45	TOUT*	25	DIAL2	05	+60V
46	FBPE	26	WGSYN	06	U-SLIC
47	TRST*	27	RGSYN	07	RCLK
48	TCK*	28	GND	08	RAC
49	TMS*	29	PRS	09	BA0
50	TDI*	30	BA1	10	RGCL
51	TDO*	31	HO1	11	RGD
52	HO3	32	HO0	12	BA6
53	HO2	33	GND	13	HD0
54	NC	34	BA2	14	BA5
55	NC	35	BA3	15	CKA
56	NC	36	-5V	16	CLS
57	HI3	37	FMB	17	HI1
58	HI2	38	HI0	18	BA4

Pin #	Signal Name	Pin #	Signal Name	Pin #	Signal Name
59	NC	39	GND	19	HDI
60	NC	40	+5V	20	-12V
* used for boundary scan testing					

6.14.6 Removing the TMEW2 Board

IMPORTANT: This procedure will remove all the channels on this trunk board from service.

NOTICE: Static Sensitive Devices! Observe all precautions for electrostatic discharge.

To remove the TMEW2 board:

1) Deactivate all channels as follows:

- a) Type `DEA-DSSU`, and then press Enter.
- b) Type the following values, and then press Enter.

```
Field      Value
OFFTYPE   DC
TYPE      PEN
PEN1      <PEN1>
PEN2      <PEN2>
```

IMPORTANT: PEN1 is the PEN of the first channel and PEN2 is the PEN of the last channel on the board.

2) Deactivate the board as follows:

- a) Type `DEA-BSSU` and press Enter.
- b) Type the following values, and then press Enter.

```
Field      Value
OFFTYPE   DC
LTG       <1 - 32>
LTU       <1 - 8>
SLOT      <1 - 151>
REFOFF    <blank>
```

3) Using the board removal and replacement tool, unseat the board and remove it from the shelf.

6.14.7 Replacing the TMEW2 Board

To replace the TMEW2 board:

- 1) Ensure that the straps on the replacement TMEW2 board are set to the same setting as the defective board.

IMPORTANT: The TMEW2 board E&M signaling is configured by software and hardware.

- 2) Slide the board into the appropriate slot until you seat it firmly into the backplane connector.
- 3) Activate the board as follows:

- a) Type ACT-BSSU and press Enter.
- b) Type the following values, and then press Enter.

Field	Value
ONTYPE	AUL
LTG	<1 - 32>
LTU	<1 - 8>
SLOT	<1 - 151>

- 4) Activate the channels as follows:

- a) Type ACT-DSSU, and then press Enter.
- b) Type the following values, and then press Enter

Field	Value
ONTYPE	AUL
TYPE	PEN
PEN1	<PEN1>
PEN2	<PEN2>

IMPORTANT: PEN1 is the PEN of the first channel and PEN2 is the PEN of the last channel on the board.

6.14.8 Verifying the TMEW2 Board

To verify the operation of the TMEW2 board:

- 1) Display the status by typing DIS-SDSU, and then press Enter
- 2) Type the following values, and then press Enter.

Field	Value
STATUS	ALL
LINK	<blank>
TYPE	PEN
LEVEL	PER3
LTG	<1 - 32>
LTU	<1 - 8>
SLOT	<1 - 151>
CCT	<0 - 15>

- 3) Verify that all the green LEDs on the board are off.

7 OpenScape Access Modules

7.1 Important information

- Each OpenScape Access Module with trunk connectivity (OpenScape Access BRI, OpenScape Access PRI) supports a/μ law conversion. In contrast to an access point, the a / μ law conversion can be defined for every OpenScape Access module in OpenScape Access. This is only possible per access point in the case of an access point.
- For configuring a/μ law conversion for OpenScape Access see [Section Generation for OpenScape Access Modules \(Example\)](#).

For more information on a/μ law conversion please refer to the service manual "**OpenScape 4000, Volume 4: IP Solutions > IP Distributed Architecture**".

- A maximum number of 8 external OpenScape Access modules can be connected to one OpenScape 4000 Branch.
- Common configuration of OSA-SLC and OSA-SLMC boards at one node (SoftGate) is not allowed and it is blocked by CaTool. The reason is - the boards can't be synchronized together which would result in disturbing each other.

NOTICE: Each OpenScape Access system must be connected with an external, permanently protective earthing conductor (sternförmige Erdung zur Potentialausgleichsschiene).

NOTICE: The OpenScape 4000 PSU is sufficiently protected on the mains power side (AC) against lightning strikes of up to 2kV. For areas at particular risk, it is recommended that additional lightning protection be provided before the connection line. The lightning ground bar with the part number C39334-Z7052-C32 offers increased protection up to 4kV.

NOTICE: Lightning protection on the boards: Analog and digital subscriber lines are protected on the boards using protection up to 2KV longitudinal voltage and 1KV transverse voltage against high-energy overvoltage in pulses from 10/700us and 1.2/50us, which can be induced by a lightning strike. This protection is only effective, however, if the system is grounded correctly in accordance with the assembly guidelines. Grounding: Once OpenScape 4000 has been grounded, check the low-impedance grounding of the system via the ground connector of the power supply circuit as well as the low-impedance connection of the additional permanently connected protective grounding conductor to the building's equipotential busbars.

NOTICE: External lightning protection: With line lengths of over 500m and if the lines leave the building, analog and digital subscriber boards must be protected by external lightning protection. This type of lightning protection is referred to as

"additional primary protection". This is either installed on the main distribution frame (MDF) or at the entry point of the line into the building. A surge arrester (ÜsAG) with a rated voltage of 230V is switched to ground by every lead that is to be protected. Without this additional primary protection, lightening which exceeds the voltage values described above can lead to the destruction of the boards. This can result in failure of the overall system or to overheating (risk of fire) of components.



WARNING: Safety cannot be guaranteed if the mains plug is inaccessible. The mains plug must be easily and safely accessible in all installation variants. Unplug the mains plug immediately in the event of danger!

- The following image shows the different housing variants of the OpenScape Access system mounted in a 19"-rack:

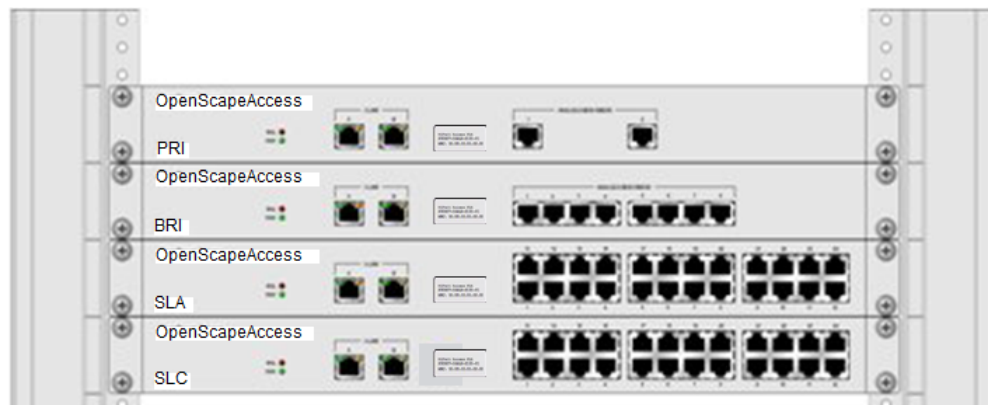

Figure 65: OpenScape Access system mounted in a 19"-rack (front view)



Figure 66: OpenScape Access system mounted in a 19"-rack (rear view)

7.2 Reference Clock

All OpenScape Access modules of a OpenScape 4000 SoftGate/OpenScape 4000 Branch are synchronized via a master/slave process in order to suppress transmission interrupts as a result of bit slip.

The reference synchronization is performed by a OpenScape Access module, which is equipped with a digital trunk connection and distributed to the other OpenScape Access modules on the same OpenScape 4000 SoftGate/ OpenScape 4000 Branch. If one or more OpenScape Access modules has a digital trunk connection, the clock master is selected according to the priority assigned in the AMO REFTA (see "[Reference Clock](#)").

Clock hierarchy

No satellites may be operated on a OpenScape Access module (BRI, PRI) that functions as a trunk, because the synchronization quality of the clock generator of the OpenScape Access module is not adequate for this. That means a OpenScape Access module shouldn't be configured as master.

It is recommended in isolated cases, however, to set up a master (connection of IVR, OpenScape Xpressions, OpenScape Alarm Response). If a OpenScape Access module is set up as a master in the AMO TDCSU, the following advisory is issued:

```
ATTENTION: IN HPA NO CLOCK GENERATOR IS PRESENT AND THE
TRUNK MODULES CANNOT
OPERATE AS CLOCK REFERENCE FOR ANY PARTNER SWITCH. IN SOME
EXCEPTIONAL CASES
ONLY MASTER CONFIGURATION IS ALLOWED E.G. CONNECTION TO
IVR/XPR/DAKS AND THEREFORE
THE CONFIGURATION MUST BE ALLOWED.
```

There are no restrictions with regard to slave operation (typical trunk connection).

7.3 X-Link Network

The X-Link network connects the different OpenScape Access modules with the OpenScape 4000 SoftGate and its integrated Mediaserver. Synchronous TDM (Time Division Multiplex) streams are exchanged in this case with the media server as well as signaling and control information with the OpenScape 4000 SoftGate.

Redundancy for OSA module X-Link ports A & B is supported with OpenScape Access, but will reduce the number of OSA modules which can be connected.

IMPORTANT: To avoid jitter and other causes of failure the X-Link should never be made accessible to the customer LAN although it is based on standard LAN components and protocols. In particular, co-usage of LAN components from the customer's management domains is not permitted, not even in the form of a virtual LAN segment (see "[Installation, Configuration, Generation and Licensing](#)").

IMPORTANT: Only screened standard LAN cables are allowed for the X-LINK. These are not part of the shipment. The X-Link cable length must not exceed 100 m and must not be extended by means of an additional switch and a LAN cable.

IMPORTANT: The LAN ports of the OpenScape Access module require autonegotiation and automatic polarity selection (Auto-MDIX). The OpenScape Access module will not start operating unless autonegotiation is working at 100MBit/s and in full-duplex mode.

7.4 OpenScape Access Module Variants

7.4.1 OpenScape Access PRI



Figure 67: OpenScape Access module PRI (front view)

- Peripheral board: DIUT3
- Status indicators (2 x LED)
- X-Link A/B (2 x— RJ-45 with LED)
- S2M interfaces (2 x RJ-45 without LED)
 - PIN 1/2: transmit
 - PIN 4/5: receive
- DB15M to RJ45 Pin outs are documented in section [DIUT2](#) on page 35.
- When migrating to Access HW from older DIU boards, please be aware a change in vendor modem maybe necessary compensate for previous Ohm differences (75 or 120) that were previously achieved though jumpers in the APPCU adaptor.

The part number for OpenScape Access PRI with DIUT3 (Q2351-X) is S30807-U6648-X171.

Predecessor modules:

S30807-U6648-X170 with DIUT2 (Q2335-X).

7.4.2 OpenScape Access SLA



Figure 68: OpenScape Access module SLA (front view)

- Peripheral board: SLMAV
- Status indicators (2 x—LED)
- X-Link A/B (2 x— RJ-45 with LED)
- Analog interfaces (24 x RJ-45 without LED)

OpenScape Access Modules

The part number for OpenScape Access SLA with SLMAV (Q2338-X) is S30807-U6648-X101.

Predecessor modules:

S30807-U6648-X100 with SLMAE (Q2331-X).

7.4.3 OpenScape Access SLO



Figure 69: OpenScape Access module SLO (front view)

- Peripheral board: SLMU
- Status indicators (2 x—LED)
- X-Link A/B (2 x— RJ-45 with LED)
- UP0 interfaces (24 x RJ-45 without LED)

The part number for OpenScape Access SLO with SLMU (Q2345-X100) is S30807-U6648-X111.

Predecessor modules:

S30807-U6648-X110 with SLMO24 (Q2333-X).

7.4.4 OpenScape Access BRI



Figure 70: OpenScape Access module BRI (front view)

- Peripheral board: STMD3
- Status indicators (2 x—LED)
- X-Link A/B (2 x— RJ-45 with LED)
- ISDN interfaces (8 x RJ-45 without LED) for CO trunk and/or S0 subscribers with external power feed

The part number for OpenScape Access BRI is S30807-U6648-X130.

7.4.5 OpenScape Access TA

For OpenScape Access TA 3 variants exist:

- 1) TA-IM: without GEE, without ground start. The part number is S30807-U6648-X150.
- 2) TA-CE: with GEE, without ground start. The part number is S30807-U6648-X140.
- 3) TA-LAM: only for Brazil, without GEE, without ground start. The part number is S30807-U6648-X160.



Figure 71: OpenScape Access module TA (front view)

- Peripheral board: TMANI
- Status indicators (2 x—LED)
- X-Link A/B (2 x— RJ-45 with LED)
- Analog interfaces (8 x RJ-45 without LED)

7.4.6 OpenScape Access SLC-M

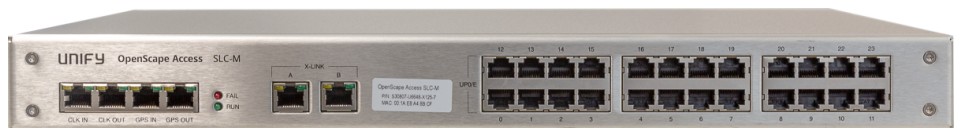

Figure 72: OpenScape Access module SLC-M (front view)

- Peripheral board: SLMC
- Status indicators (2 x— LED)
- X-Link A/B (2 x— RJ-45 with LED)
- UP0 interfaces (24 x RJ-45 without LED)
- There may be max. 6 OSA SLC-M modules connected per OpenScape 4000 SoftGate/Branch.
- 8P/8C interfaces (4 x RJ 45 with LED): CLK in, CLK out, GPS in, GPS out.

The part number for OpenScape Access SLC-M is S30807-U6648-X125.

7.4.7 Rear view of all OpenScape Access Modules



Figure 73: OpenScape Access module (rear view)

- Power inlet (IEC 320 socket with switch)
- PE connection (screw with clamp)

7.4.8 Dimensions and Weights

Table 48: Dimnsions and weights

Type	Width x Depth x Height (mm)	Weight
OpenScape 4000 Branch	435 x 355 x 63 (1,5 U)	7,0 kg

OpenScape Access Modules

Type	Width x Depth x Height (mm)	Weight
OpenScape Access SLA	440 x 350 x 45 (1 U)	4,4 kg
OpenScape Access SLO	440 x 350 x 45 (1 U)	3,8 kg
OpenScape Access BRI	440 x 350 x 45 (1 U)	3,8 kg
OpenScape Access PRI	440 x 350 x 45 (1 U)	3,8 kg
OpenScape Access SLC	440 x 350 x 45 (1 U)	3,8 kg
OpenScape Access SLC-M	440 x 350 x 45 (1 U)	3,8 kg
OpenScape Access TA	440 x 350 x 45 (1 U)	3,8 kg

7.4.9 Environmental and Operating Conditions

Table 49: Environmental and operating conditions

Air temperature	0°C to + 40°C
Relative humidity	5% - 85%

7.4.10 Power Consumption

Table 50: Power Consumption

Name	Size	Input Voltage Range	Power Supply	Typ. Power	Max. Power
OpenScape 4000 Branch	1.5 U	110 VAC to 240 VAC	ATX 250W - 48V 35W	2,5 W off/ 55 W - 75 W depending on load + 2 W per SLA-port (all typ.)	240 W
OpenScape Access SLA	1 U		- 48V 90W	10 W (typ.) idle + 2 W per port offhook	90W
OpenScape Access SLO	1 U		- 48V 90W	6 W (typ.) idle + 1 W per connected port	90W
OpenScape Access SLC	1 U		- 48V 90W	8W (typ.) idle + 2W per additional Up0 port used	90W
OpenScape Access SLC-M	1 U		- 48V 90W	8W (typ.) idle + 2W per additional Up0 port used	90W
OpenScape Access BRI	1 U		5V 10W	6,5 W (typ.) all conditions	10W
OpenScape Access PRI	1 U		5V 10W	4 W (typ.) all conditions	10W

Name	Size	Input Voltage Range	Power Supply	Typ. Power	Max. Power
OpenScape Access TA-IM	1 U		5V 10W	4 W (typ.) all conditions	10W
OpenScape Access TA-CE	1 U		-48V 25W	3.7W	25W
OpenScape Access TA-LAM	1 U		5V 10W	tbd	10W

7.5 Installation, Configuration, Generation and Licensing

7.5.1 Generation for OpenScape Access Modules (Example)

7.5.1.1 OpenScape Access Modules

The configuration of the OpenScape Access modules is done with AMO BCSU. For OpenScape Access additionally to the known configuration parameters for a peripheral board a MAC address must be entered. The appropriate MAC address can be found on the label which sticks on the front panel of each OpenScape Access module. If the MAC address of the OpenScape Access module is not yet known, the dummy MAC address "00-00-00-00-00-00" can be used for configuration purposes. This means that subscribers and records can be configured in advance. The correct MAC address must then be entered when starting up the OpenScape Access module (CHANGE-BCSU).

OpenScape Access supports a/μ law conversion per OpenScape Access BRI/PRI. The following values are available for the parameter **TDMLAW**: (During last changes in RMX, TDMLAW is unblocked for every OSA)

0	no conversion (default/system)
1	a law
2	μ law

SLA - Q2338-X

```
ADD-BCSU:MTYPE=PER,LTG=1,LTU=18,SLOT=5,PARTNO="Q2338-X",FCTID=0,LWVAR=0,HWYBDL=A,ALARMNO=0,MACADDR=00-1A-E8-00-68-31;
```

BRI - Q2332-X

```
ADD-BCSU:MTYPE=PER,LTG=1,LTU=18,SLOT=2,PARTNO="Q2332-X",FCTID=1,LWVAR=0,HWYBDL=A,ALARMNO=0,MACADDR=00-1A-E8-0D-AF-F6,TDMLAW=0;
```

SLO - Q2333-X

```
ADD-BCSU:MTYPE=PER,LTG=1,LTU=18,SLOT=3,PARTNO="Q2333-
X",FCTID=1,LWVAR=0,ACTFC=NO,STERM=300,LTERM=700,PTERM=300,HWYBDL=A,AL
E8-00-6A-40;
```

SLC - Q2334-X200

```
ADD-BCSU:MTYPE=PER,LTG=1,LTU=18,SLOT=8,PARTNO="Q2334-
X200",FCTID=0,LWVAR=5,CIRCNT=216,HWYBDL=A,ALARMNO=0,MACADDR=00-1A-
E8-32-60-74;
```

SLMC - Q2345-X

```
ADD-BCSU:MTYPE=PER,LTG=1,LTU=18,SLOT=8,PARTNO="Q2345-
X",FCTID=0,LWVAR=4,CIRCNT=216,ALARMNO=0,MACADDR=00-1A-
E8-9B-80-08;
```

PRI - Q2351-X

```
ADD-BCSU:MTYPE=DIU,LTG=1,LTU=19,SLOT=3,PARTNO="Q2351-
X",LWVAR=0,FCTID=1,HWYBDL=A,ALARMNO=0,MACADDR=00-1A-
E8-32-60-5E,TDMLAW=0;
```

TA-IM - Q2336-X101

```
ADD-BCSU:MTYPE=DIU,LTG=1,LTU=19,SLOT=4,PARTNO="Q2336-
X101",LWVAR=0,FCTID=1,HWYBDL=A,ALARMNO=0,MACADDR=00-1A-
E8-32-60-5E,TDMLAW=0;
```

7.5.1.2 Analog Ports in OpenScape EcoBranch

SLMAV4 Q2346 configuration i.e.:

```
ADD-BCSU:MTYPE=PER,LTG=1,LTU=20,SLOT=1,PARTNO="Q2346-
X",FCTID=0,LWVAR="0",ALARMNO=0,MACADDR=00-20-CE-FE-40-35;
```

7.5.1.3 Reference Clock

There are no changes to the AMO REFTA commands for setting up the reference clock table:

```
ADD-
REFTA:TYPE=CIRCUIT,PEN=1-19-3-1,PRI=74,BLOCK=N,READYASY=N;
ADD-
REFTA:TYPE=CIRCUIT,PEN=1-19-10-0,PRI=75,BLOCK=N,READYASY=N;
```

The DISPLAY-REFTA display is extended as follows however: Every selected reference clock record of a OpenScape Access module with a digital trunk connection is identified by an asterisk (*). The asterisk (*) is replaced by an X for the selected clock master with the highest priority.

```
DIS-REFTA:TYPE=CIRCUIT,KIND=ACT;
```

```
H500: AMO REFTA STARTED
```

```

+-----+
|           REFERENCE CLOCK CIRCUITS           |
+-----+-----+-----+-----+-----+-----+
| PEN      | MODULE | DEVICE | PRI|ERROR |BLOCK |SUPP. |READY|SRCGRP|

```

```

|          |          |          | |          |          |          |          |          |          |          |
|          |          |          | |          |          |          |          |          |          |          |
+-----+-----+-----+-----+-----+-----+-----+-----+-----+-----+
| 1-19- 3- 1 | DIUT2 | S2CONN | 74| 16000| N | * | N | 2|
| 1-19-10- 0 | DIUT2 | S2CONN | 75| 16000| N | X | N | 2|
+-----+-----+-----+-----+-----+-----+-----+-----+-----+-----+
AMO-REFTA-243      REFERENCE CLOCK TABLE
DISPLAY COMPLETED;

```

In the example, a reference clock has been activated on both DIUT2 modules by a connected AMT, which means that both records therefore get at least one *.

The activated record 1-19-10-0 has a higher priority than the activated record 1-19-3-1 and is therefore selected as the clock master (* -> X). The clock master supplies the synchronization for all OpenScape Access modules in the same shelf, which do not have their own trunk connection (e.g. OpenScape Access SLO, OpenScape Access SLA, ...).

This means that the OpenScape Access modules with their own clock generator fetch their own synchronization. The clock master supplies the OpenScape Access modules that do not have their own clock generator.

8 Power FRUs

NOTICE: The power supplies of the EcoServer are described in Chapter 3.

8.1 LUNA 2

The AC-to-DC shelf power supply unit (LUNA 2) converts AC power to DC on the OpenScape 4000 IP Distributed Architecture (IPDA) system. The nominal AC input voltage is 90-264 VAC from the utility outlet that provides power to the cabinet. The DC output voltages are: -5.0 V, +5.1 V, +12 V, -12 V and -48 V. The frequency is between 47 Hertz (Hz) and 63 Hz.

In case of DC systems and/or battery operation, the LUNA 2 uses -48V DC input.

8.1.1 LED Indications and Switches

The front panel features one green LED and two slide switches:

- Green LED: This indicates whether the individual voltages are within tolerance. If the voltage is outside tolerance, the LED goes out. Depending on the operating mode, the LED may illuminate or flash.
- Switch 1: On/off power supply switch

- Switch 2: Operating mode switch The power supply unit can be used for supplying power or charging the battery. Set the operating switch to the correct position (see front panel labelling). Operating modes:
 - Mode 1: as a power supply unit (LED is lit)
 - Mode 2a: as a battery charger (flashing LED) for maintenance-free dry-cell batteries (charging voltage: 54.7 VDC)
 - Mode 2b: as a battery charger (flashing LED) for wet-cell batteries requiring low charging voltage (53.5 VDC)

The LUNA 2 provides voltages specified in [Table 39](#):

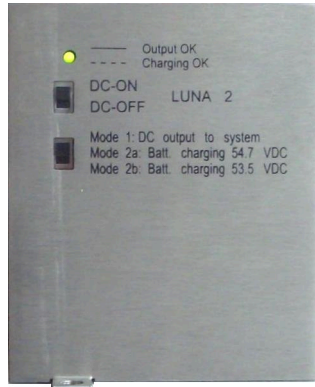

Figure 74: LUNA 2 - Front view

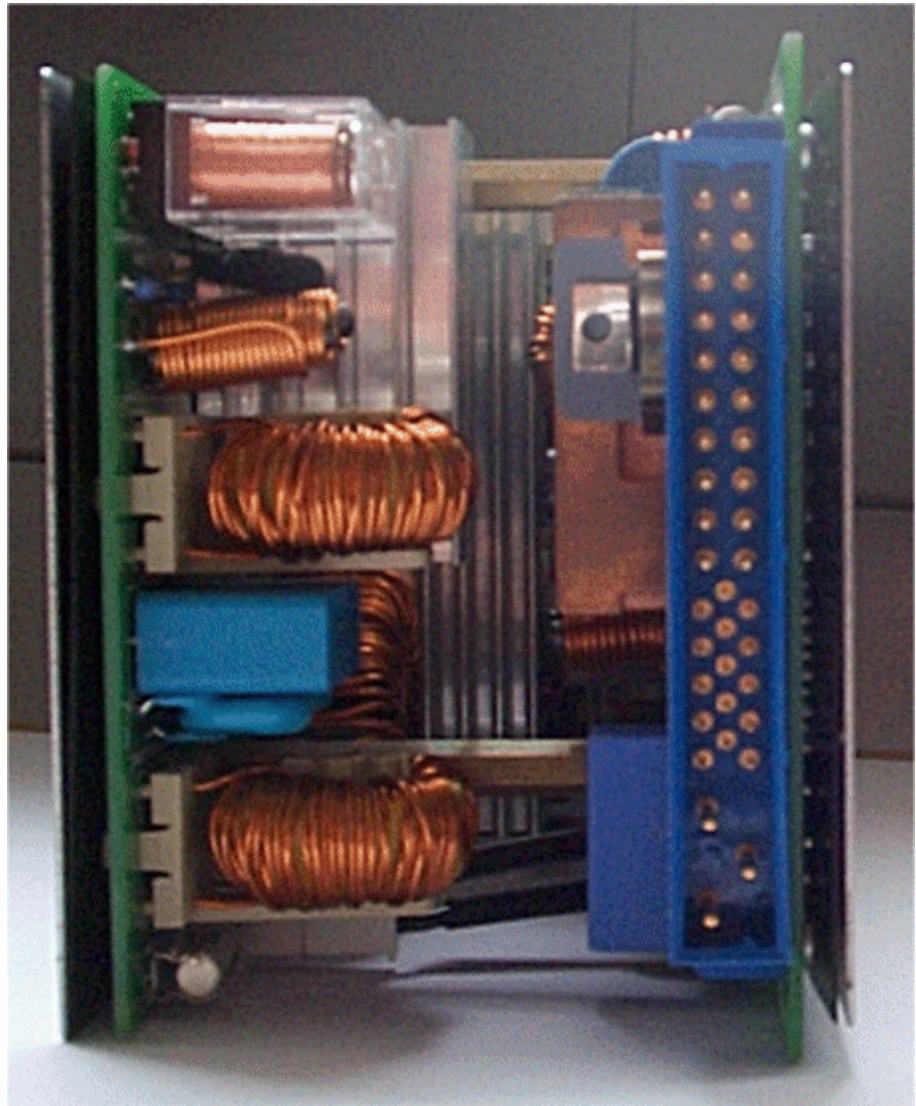

Figure 75: LUNA 2 - Back view

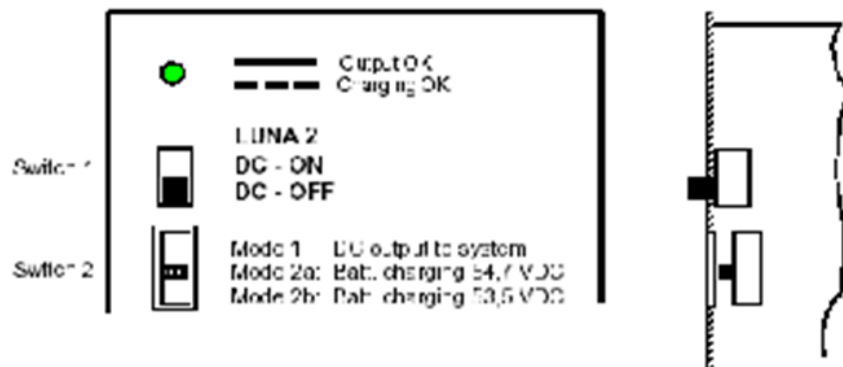

Figure 76: LUNA 2 (Front and Back View)

Table 51: LUNA 2 PIN Assignment

	PIN	PIN	PIN		
DC IN (minus pole)	2		1	DC IN (minus pole)	DC output voltage
U6 (-48 VDC)	4		3	GND	
GND	6		5	GND	
nc	8		7	nc	
U3 (-5 VDC)	10		9	GND	
U5 (-12 VDC)	12		11	GND	
U4 (+12 VDC)	14		13	GND	
GND	16		15	GND	
U1 (+5.1 VDC)	18		17	U1 (+5.1 VDC)	
U1 (+5.1 VDC)	20		19	U2 (+5.1 VL)	
		21			Logic signals
	23		22	U1 current +sense	
System Identification SI 1 (SDA)		24			
SI 2 (SLC)	26		25	U6 current +sense	
Si 3 (reserved)		27			
PFL (DC Power Fail)	29		28	NGA (AC Power Fail)	
		30		Identify PIN_A0	
Identify PIN_A3	32		31	Identify PIN_A1	
		33			

	PIN	PIN	PIN		
	35		34		
PE	36				Power supply unit
			37	Neutral (N)	
Phase (L)	38				

8.1.2 Removing the LUNA 2

To remove the LUNA 2, unfasten the two screws on the front panel of the power supply.

The LUNA2 power supply supports the hot plug feature, which means, it can be turned on or off, removed or inserted, without turning off the system power.

8.1.3 Replacing the LUNA 2

To replace the LUNA 2, tighten the two screws on the front panel of the power supply unit.

The LUNA2 power supply supports the hot plug feature, which means, it can be turned on or off, removed or inserted, without turning off the system power.

8.1.4 Verifying the LUNA 2

To verify the LUNA 2, observe the green LED on the front panel.

- If the LED is lit, the voltages are OK
- If the LED is flashing, the battery is charging properly.

8.1.5 Power Failure Bridging for LUNA2

If LUNA2 is working only with AC input, in case of AC input power interruptions, the LUNA2 continues in normal operation during 30ms after AC input is removed.

If LUNA2 power supply has an additional DC feeding by battery, a continual crossing to DC backup without any break of secondary output must be given.

8.2 LUNA 3

The AC-to-DC shelf power supply unit (LUNA 3) converts AC power to DC on the OpenScape 4000 IP Distributed Architecture (IPDA) system. The nominal AC input voltage is 90-264 VAC from the utility outlet that provides power to the

cabinet. The DC output voltages are: -5.0 V, +5.1 V, +12 V, -12 V and -48 V. The frequency is between 47 Hertz (Hz) and 63 Hz.

In case of DC systems and/or battery operation, the LUNA 3 uses -48V DC input.

NOTICE:

The LUNA3 is technically equivalent to the LUNA2 and provides the same functional capabilities and electrical characteristics.

The LUNA3 differs from the LUNA2 only in its front panel design, LED indications, and operating concept.

8.2.1 LED Indications and Switches

The front panel features a tricolor LED for indication of power supply status and one slide switch.

- Tri-color LED: It supports multiple color and flashing combinations to represent different operating and status conditions. It shows that each individual voltage is within tolerance when the green LED is steadily illuminated. If the voltage is outside tolerance, the LED goes out. Depending on the operating mode, the LED may illuminate or flash.
- Switch 1: On/off power supply switch
- Power supply operation. The LUNA3 powers the system and enables all outputs. This is the only supported operating mode.

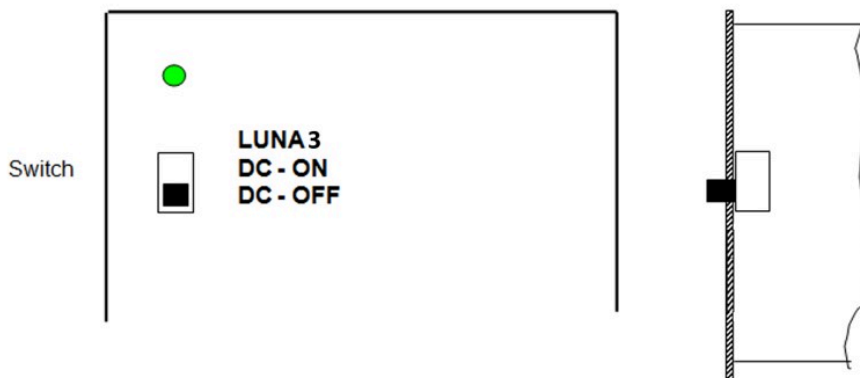

Figure 77: LUNA 3 - Front panel

Table 52: LUNA 3 LED status

	Green (continuous)	Orange (continuous)	Orange (intermittent)	Red (continuous)	Red (intermittent)
All DC outputs are within the operating range.	x				
Power down / sleep mode (via I2C)		x			

Power FRUs

UACD (Lineage Power) 19-Inch Installation

	Green (continuous)	Orange (continuous)	Orange (intermittent)	Red (continuous)	Red (intermittent)
Input overvoltage and undervoltage protection (automatic return)			x		
Overvoltage at outputs (latch off)				x	
Overload or short circuit at outputs (automatic return)					x

8.2.2 Removing the LUNA 3

To remove the LUNA 3, unfasten the two screws on the front panel of the power supply.

The LUNA 3 power supply supports the hot plug feature, which means, it can be turned on or off, removed or inserted, without turning off the system power.

8.2.3 Replacing the LUNA 3

To replace the LUNA 3, tighten the two screws on the front panel of the power supply unit.

The LUNA 3 power supply supports the hot plug feature, which means, it can be turned on or off, removed or inserted, without turning off the system power.

8.2.4 Verifying the LUNA 3

To verify the LUNA 3, observe the tri-color LED on the front panel.

A steady or flashing indication provides visual feedback on the operating state and voltage status according to the defined LED patterns described in the figures "LUNA3 specification for front LED (a)" and "LUNA3 specification for front LED (b)".

- If the LED indicates normal operation, the output voltages are within tolerance.

8.2.5 Power Failure Bridging for LUNA 3

If LUNA 3 is working only with AC input, in case of AC input power interruptions, the LUNA3 continues in normal operation during 30 ms after AC input is removed.

If LUNA 3 power supply has an additional DC feeding, a continual crossing to DC backup without any break of secondary output must be ensured. Battery-based backup charging is not supported in LUNA 3.

8.3 UACD (Lineage Power) 19-Inch Installation

8.3.1 Overview

The UACD is a total power system that supports -48V loads of up to 120 amperes, N+1, in a single shelf and up to 300 amperes, N+1, in a dual shelf. The highly rugged rectifier and battery charger features include, high efficiency, single phase, hot-pluggable and fan-cooled. The constant output power (3000W i.e. 55.5A at 54V) feature supplies the specified power over the full output voltage range (-48 to -58 Vdc). Other advanced features include, automatic load-share that forces the power units to apportion the plant load equally, reducing the stress on individual units. The rectifier is designed to operate in ambient temperatures up to +55°C. These power units are self-protected so that short circuits and system overloads are handled automatically; i.e., if a short circuit is removed or a system overload reduced, the power units will automatically resume normal operations.

The Pulsar Edge controller is the nerve center of the battery plant. It monitors and controls the plant rectifiers, distribution, and batteries. It also provides local and remote interface.

IMPORTANT: A Installation without 19 inch is not supported (details for installation, see OpenScape 4000 Installation Instruction).

The UACD power box (Lineage Power) is a new AC/DC power box for use in 19-inch cabinets which replaces the old UACD (PSR930/PSR930E).

It consists of the following 19-inch mounting units:

- Primary Shelf UACD-A (with the QS841E controller board)
- Secondary Shelf UACD-B

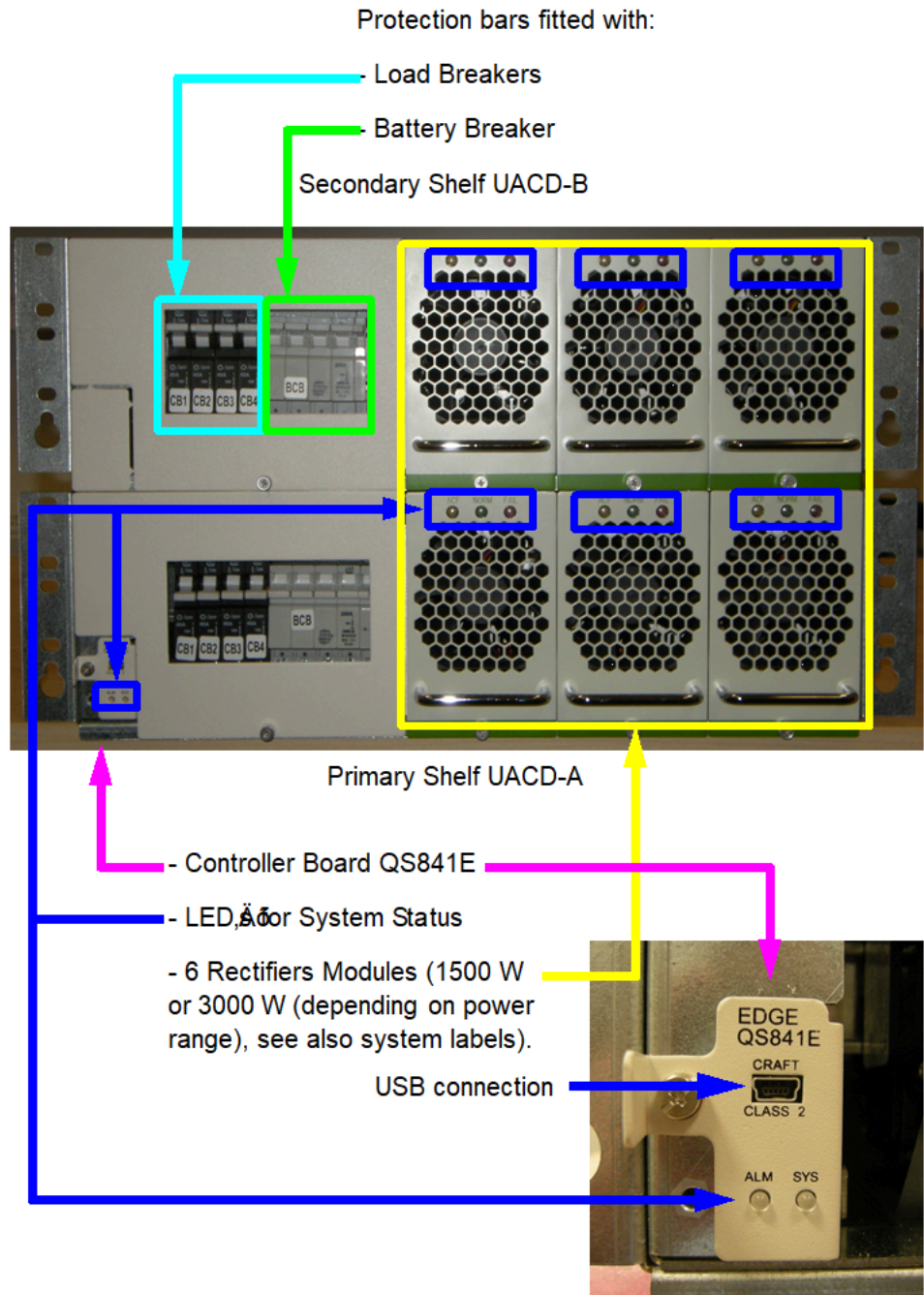

Figure 78: UACD-A&B - Front View (Details)

- The equipment comes with all circuit breakers already equipped.
- The UACD expansion cabinet (UACD Secondary Shelf) has the same structure as the base cabinet minus the base controller.

8.3.2 Technical parameters

Table 53: Technical parameters for UACD (Lineage Power)

Parameter	Specification
General	
Input Voltage Range	90 - 300 Vac
Operating Temperature Range	5Â°C to +55 Â°C
Storage Temperature Range	-40Â°C to 85 Â°C
Physical Specifications	8,75 inch x 16,26 inch x 15,18 inch (HxWxD)
Mounting Requirements	Rack mounted 19" frame
Input/Outputs	
Form C Alarm Output Contact Ratings	60 VDC at 0,5 A
Plant Voltage Measurement Accuracy - 0 to 50 Â°C (+/- 1% of full scale +10 count) - -40 to 85 Â°C (+/- 2% of full scale +10 count) - Resolution	- 48 V Systems: +/- 40 mV - 48 V Systems: +/- 70 mV 0,01 V
Plant Current Measurement Accuracy Resolution	- 0 to +50 Â°C: +/- 0,5% of full scale - -40 to +85 Â°C: +/- 1,25% of full scale - 1 A
Temperature Measurement Accuracy - One-Wire Serial probes - Resolution	-40 to +85 Â°C: +/- 3 Â°C 0,1 Â°C
Safety and Standards	
Electrostatic Discharge	IEC61000-4-2
Radiated Emissions	FCC Class A, CISPR 22 level A
Safety	UL recognized component

Power FRUs

UDCD (Lineage Power)

8.4 UDCD (Lineage Power)

The UDCD powerbox from Lineage Power will be used in the future as a replacement for the previous powerbox, which was fitted with Zytron power supplies.

IMPORTANT: The initial installation for the UDCD and their documentation will be covered by local company in US.

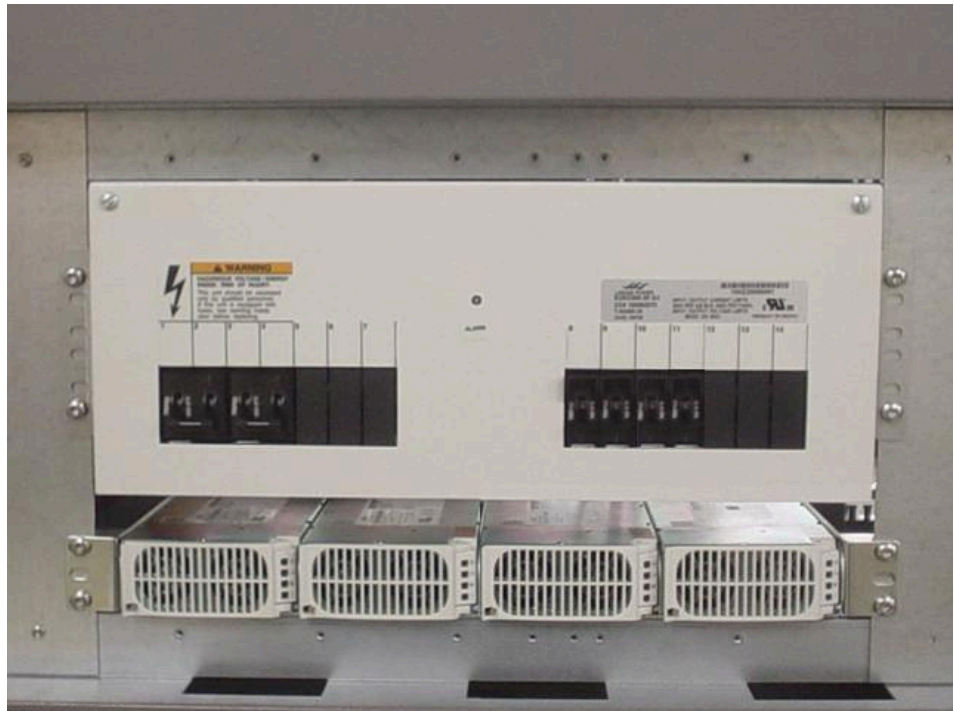

Figure 79: Lineage Powerbox (complete configuration)

9 Legacy Hardware

This chapter describes the components that are not available for new OpenScape V10 systems.

9.1 SHELF FRUs

This chapter describes the individual shelves and the procedures for removing, replacing and verifying them in a OpenScape 4000 system.

9.1.1 L80XF Shelf

The L80XF shelf is the expansion shelf for AC-powered, non-redundant OpenScape 4000 systems. The L80XF shelf is available in two variants:

- I.M.-this type uses 60-pin SIVAPAC MDF cables that directly connect to the back of peripheral module plugs
- U.S.-this type uses 50-pin Champ cables that connect to additional Champ plugs

The L80XF shelf provides slots for:

- One LTUCA board
- 16 Peripheral card
- One AC-to-DC shelf power supply (LPC80)
- One DC-to-DC shelf power supply (PSUP)
- One special slot to access a limited number of highways Connectors

Figure 49 shows the connectors on the L80XF backplane.

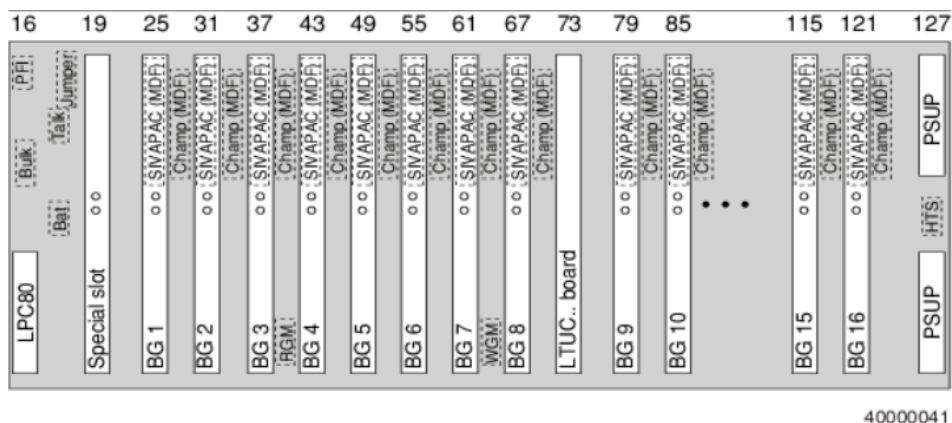

Figure 80: L80XF Backplane

Table 41 describes the connectors at the back of the OpenScape 4000 L80XF shelf.

Table 54: L80XF Shelf Connectors (Back View)

Location	Connector Description
PF1	A power fail signal (PFPS) connector between the PSDSC and the processor card. In a DC-powered system, the signals may serve as alarm input from an external power supply.
BAT	A two-pin mate-N-Lok connector for an optional battery. This interface is used when a backplane is replaced. Note: This is not used in the U.S.
Bulk	A two-pin mate-N-Lok connector for an external power supply connection. Note: This is not used in the U.S.
Talk	A two-pin mate-N-Lok connector for an external power supply connection. Note: This is not used in the U.S.
Jumper	A 10-pin mini connector is used to jump the ringing signal and corresponding synchronization signal from the power supply to the slots. Note: The jumper must be removed in systems with a PSAFE power supply and an external ringer module or an enhanced ringer board.
SIVAPAC (MDF)	Sixteen Champ or SIVAPAC MDF connectors
RGM	A 10-pin mini connector is used to jump the ringing signal and corresponding synchronization signal from the power supply to the slots.
WGM	A connector for a WG module. A 10-pin Mini connector is provided.
HTS	A 3-pin mate-N-Lok connector to supply optional HiPath Trading adapters with +5 V and GND. Since the MDF champ connector does not have a power pin, the adapter is only used in the North American (NA) market.

9.1.1.1 Removing the L80XF Backplane



DANGER:

Use extreme caution when working on the L80XF shelf. Live voltages are present at the back of the other shelves in the cabinet. Observe all applicable electrical safety precautions for working with high voltages.

Do not wear an ESD strap when working at the back of the L80XF.

NOTICE:**Static Sensitive Devices!**Observe all precautions for electrostatic discharge.

To remove the L80XF backplane:

- 1) Remove power on the shelf.
- 2) Remove the shelf power supplies (LPC80 and PSUP).
- 3) Note the slot number of each board in the shelf.
- 4) Using the board extractor, unseat and remove all the boards from the shelf.
- 5) Remove the ESD wrist strap.
- 6) At the back of the L80XF shelf, label any unlabeled cables to identify the matching connector locations.
- 7) Disconnect all cables.
- 8) At the back of the shelf, remove the screws that secure the backplane to the shelf.
- 9) Remove the backplane from the shelf.

9.1.1.2 Replacing the L80XF Backplane

To replace the L80XF backplane

- 1) Install and secure the backplane onto the shelf with screws.
- 2) Install the shelf power supplies into the shelf until it is seated into the connectors.
- 3) Tighten the screws on the clamps to secure the DC-to-DC shelf power supplies to the shelf.
- 4) Slide each board into the appropriate slot until you seat them all firmly into the backplane connectors.
- 5) Reconnect all the cables.
- 6) Turn on the L80X shelf.

9.1.1.3 Verifying the L80XF Shelf

To verify the L80XF shelf:

- 1) Verify that the green LED on the shelf power supplies in the L80XF shelf are lit.
- 2) Perform the verification procedures associated with removal and replacement of each board in the L80XF shelf.
- 3) Display the status of the L80XF shelf as follows:
 - a) Type `DIS-SDSU` and press Enter.
 - b) Type the following values, then press Enter.

Field	Value
STATUS	ALL
LINK	<blank>
TYPE	UNIT
PID	BP<G

9.1.2 LTUW Shelf

The LTUW shelf is the new version of the LTUE shelf. It functions as an interface between the system and the external environment.

The L80XF shelf is available in two variants:

- I.M. -this type uses 60-pin SIVAPAC MDF cables that directly connect to the back of peripheral module plugs
- U.S.-this type uses 50-pin Champ cables that connect to additional Champ plugs

The LTUW shelf is only used in a OpenScape 4000, AC and DC-powered, redundant system.

The LTUW shelf provides slots for:

- Two DC-to-DC shelf power supply units (PSUPs)
- 16 peripheral slots, up to 24 ports in narrowband
- A special slot for RG or peripheral signaling interface unit (SIU)
- One LTUCA board

9.1.2.1 Connectors

Figure 50 shows the connectors on the LTUW backplane.

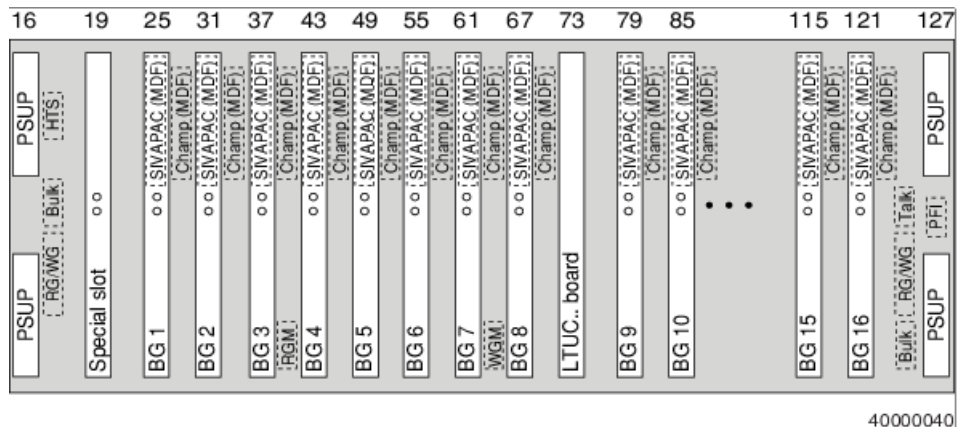

Figure 81: LTUW Backplane

LTUW Backplane

Table 42 describes the connectors on the LTUWF backplane.

Table 55: LTUW Shelf Connectors

Location	Connector Description
RG/WG	Two 2X5 pin Mini connectors used to share the ring generator and WG signals between two shelves. The signal RINGREF is necessary to achieve balanced ringing.
Bulk	Two input power connectors for DC-to-DC power supplies (PSUP) bulk

Location	Connector Description
Talk	A two-pin mate-N-Lok connector for talk power on analog telephones
HTS	A 3-pin mate-N-Lok connector to supply optional HiPath Trading adapters with +5 V and GND. Since the MDF champ connector does not have a power pin, the adapter is only used in the North American (NA) market.
RGM	A 10-pin Mini connector for a ringer module.
WGM	A 10-pin Mini connector for a WG module.
PF1	A power fail signal (PFPS) connector between the PSDSC and the processor card. In a DC-powered system, the signals may serve as alarm input from an external power supply.

9.1.2.2 Removing the LTUW Backplane



DANGER: Use extreme caution when working on the LTUW shelf. Live voltages are present at the back of the other shelves in the cabinet. Observe all applicable electrical safety precautions for working with high voltages. Do not wear an ESD strap when working at the back of the LTUW.

NOTICE: Static Sensitive Devices! Observe all precautions for electrostatic discharge.

To remove the LTUW backplane as follows:

- 1) Turn off the power supply to the shelf.
- 2) Note the slot number of each board in the shelf.
- 3) Using the board extractor, unseat and remove all the boards from the shelf.
- 4) Remove the DC-to-DC shelf power supply units.
- 5) Remove the ESD wrist strap.
- 6) At the back of the LTUW shelf, label any unlabeled cables to identify the matching connector locations.
- 7) Disconnect all cables.
- 8) At the back of the shelf, remove the screws that secure the backplane to the shelf.
- 9) Remove the backplane from the shelf.

9.1.2.3 Replacing the LTUW Backplane

To replace the LTUW backplane:

- 1) Install and secure the backplane onto the shelf with screws.
- 2) Install the DC-to-DC shelf power supplies into the shelf until it is seated into the connectors.

- 3) Tighten the screws on the clamps to secure the DC-to-DC shelf power supplies to the shelf.
- 4) Slide each board into the appropriate slot until you seat them all firmly into the backplane connectors.
- 5) Reconnect all the cables.
- 6) Turn on the LTUW shelf:

9.1.2.4 Verifying the LTUW Shelf

To verify the LTUW shelf:

- 1) Verify that the green LEDs on the DC-to-DC shelf power supply units in the LTUW shelf are lit.
- 2) Perform the verification procedures associated with removal and replacement of each board in the LTUW shelf.
- 3) Display the status of the LTUW shelf as follows:
 - a) Type `DIS-SDSU` and press Enter.
 - b) Type the following values, then press Enter.

Field	Value
STATUS	ALL
LINK	<blank>
TYPE	UNIT
PID	BP<G

9.1.3 IPDA Architecture

OpenScape 4000 facilitates the distribution of access points over an IP network. These access points are shelves (AP 3300 IP or AP 3700-9 IP), which accommodate standard OpenScape 4000 interface modules. The stations at the access points are treated in exactly the same way as if they were directly connected to a OpenScape 4000 system as before. All IP-distributed components are administered as a **single** system over one OpenScape 4000 system connection point.

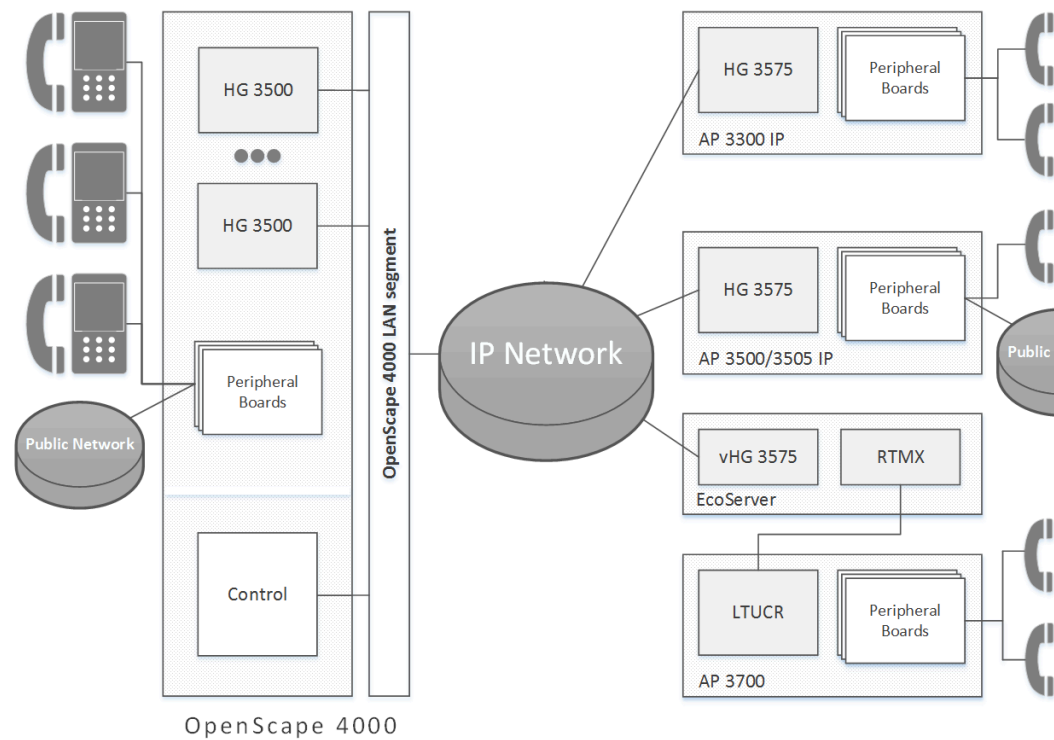

Figure 82: System architecture overview

9.1.3.1 Equipment

Depending on the system configuration, an access point can consist of a basic box and an expansion box.

The shelf slots in the basic box are assigned to the following hardware components:

- Slot 1- 5: Peripheral modules
- Slot 6: Central control board
 - LTUCR in case of Enterprise Gateway solution
- Slot 7 - 10: Peripheral modules
- Up to three power supply units LUNA 2/ LUNA 3

The shelf slots in the expansion box are assigned to the following hardware components:

- Slot 1 -6: Peripheral modules
- Slot 7: Central control board
 - LTUCR in case of Enterprise Gateway solution
- Slot 8 - 14: Peripheral modules
- Up to four power supply units LUNA 2/ LUNA 3

9.1.4 AP 3700-9 Shelf

Part number: S30805-G5412-X

The AP 3700-9 is a peripheral shelf with an NCUI control board that can be installed as a standalone system or in a 19" cabinet system. The AP 3700-9 can be populated with up to nine peripheral modules.

In addition, a separate CompactPCI cassette can be installed in the shelf as a Survivability server.

9.1.4.1 Shelf Population (Front)

Figure 52 shows a front view of AP 3700-9.

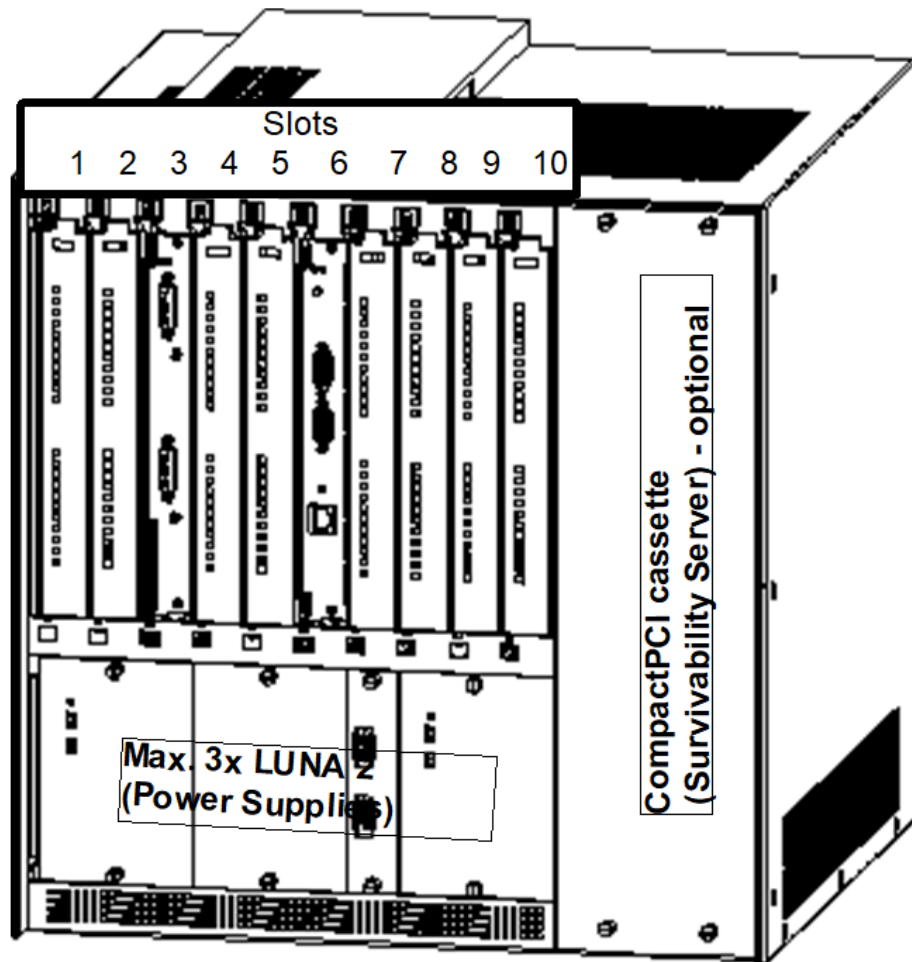

Figure 83: AP 3700-9 Front View

- Slot 1 - 5: Peripheral modules
- Slot 6: Central control board NCUI (AP3700-9)/CBSAP (H3800BB)
- Slot 7 - 10: Peripheral modules
- Up to three power supply units LUNA 2/ LUNA 3
- REALS (Relays and ALUM for SAPP), used in H3800BB (HiPath 3000) only
- CompactPCI cassette (Survivability Server), used in AP 3700-9 (OpenScape 4000)

9.1.4.2 Shelf Population (Back) with Patch Panels

Figure 53 shows the back view of the AP 3700-9 populated with patch panels

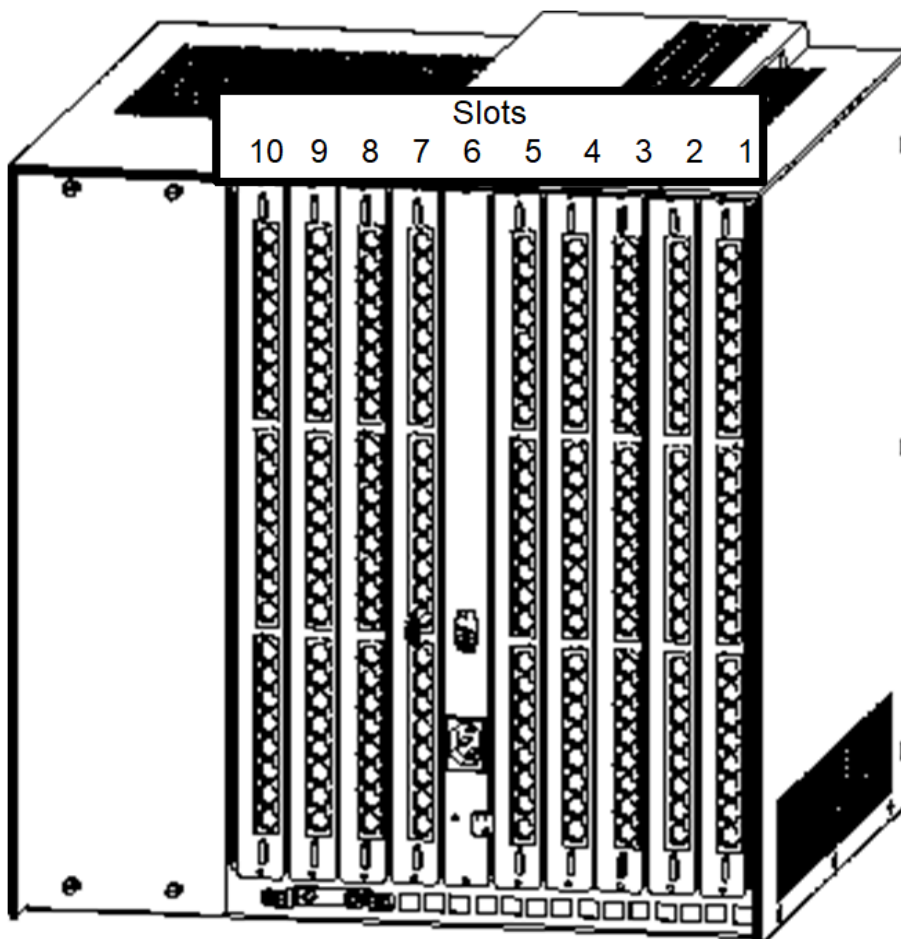

Figure 84: AP 3700-9 (Back View) Populated with Patch Panels

- Slot 10 -7: Patch panels (8, 20 and 24-port RJ-45 connector/CHAMP plug)
- Slot 6: Power supply connection board (DC at the top/AC at the bottom)
- Slot 5 -1: Patch panels (8, 20 and 24-port RJ-45 connector/CHAMP plug)
- Cable clip for earth connection

9.1.4.3 Shelf Population (Back) without Patch Panels

Figure 54 shows the back view of the AP 3700-9 without patch panels

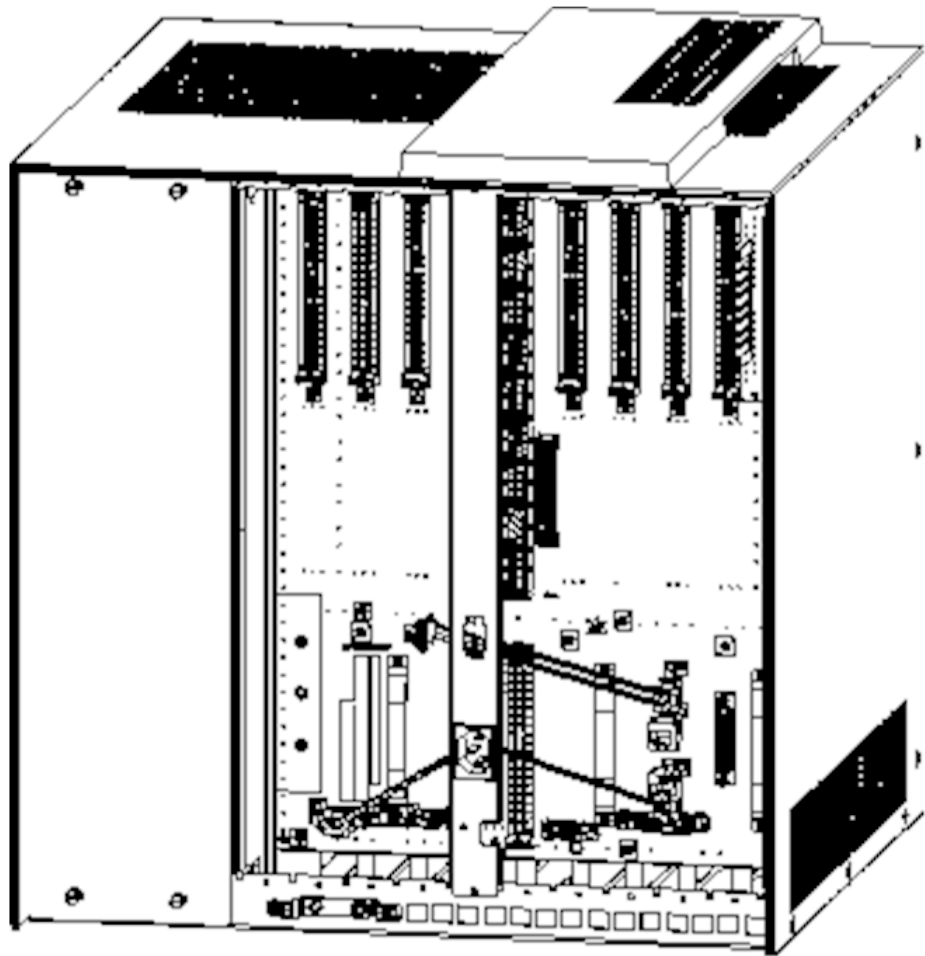

Figure 85: AP 3700-9 (Back View) without Patch Panels

- SIVAPAC cables on the backplane for connection to external patch panels or to a main distribution frame (MDF)
- Power supply connection board (DC at the top/AC at the bottom)
- Cable clip for earth connection

9.1.4.4 AP 3700-9 Backplane Connections

[Figure 55](#) shows the AP 3700-9 backplane connections

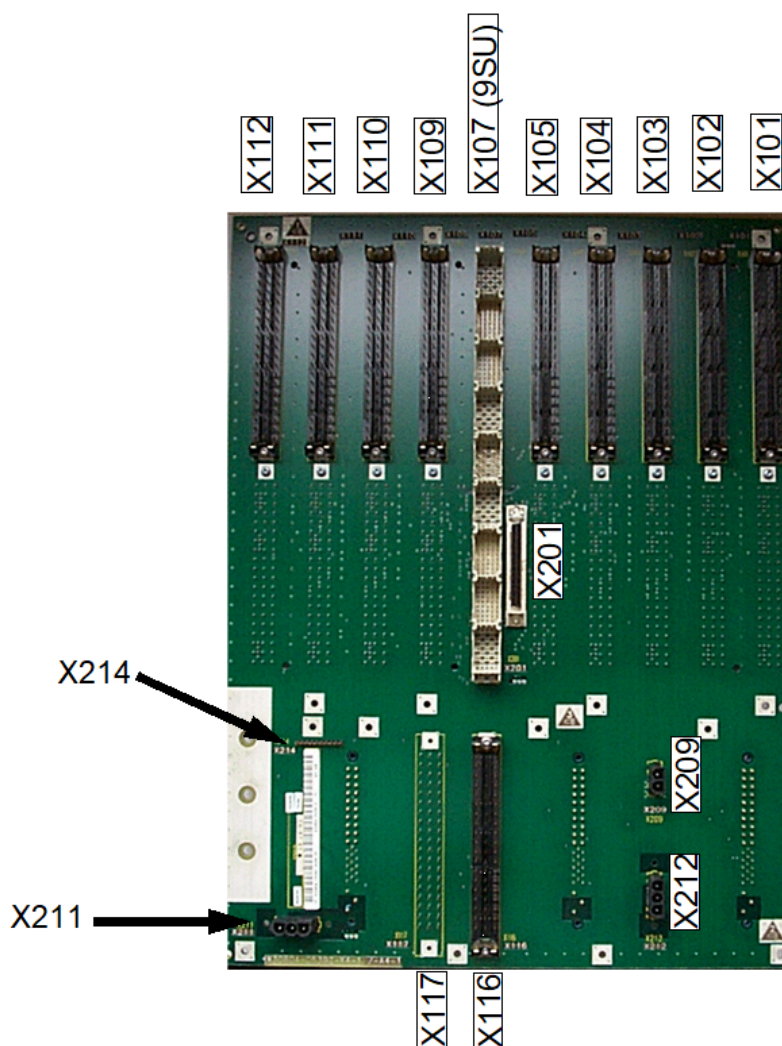

Figure 86: AP 3700-9 Backplane Connections

- Connector X101 - X105: SIVAPAC connector for peripheral connections
- Connector X107 (9SU): SIPAC connector for external signalling (e.g. reference clock)
- Connector X109 - X112: SIVAPAC connector for peripheral connections
- Connector 116/117: SIVAPAC connector (REALS, ALUM)
- Connector 201: DB68mini (for expansion box)
- Connector 209: DC connection
- Connector 211/212: AC connection

9.1.5 Survivability Server

Survivability Server takes over operation of the access points if central control fails. It can only be used in AP 3700 IP access points.

However, Survivability Server can control all types of IPDA access points (AP 3300 IP, AP 3500 IP, AP 3700 IP) in emergency situations, regardless of whether the access points are equipped with NCUI(1), NCUI2 or NCUI4.

Survivability Server consists of a cassette with a cPCI backplane, DSCXL processor with HD, power supply unit and redundant ventilator modules.

Depending on the power supply module used, it can operate with 110/230V AC or 48 V DC. In AP 3700 IP, there is no electrical connection between the access point and the server.

Survivability Server and the access point NCUI communicate with each other exclusively via the IP network (see also service manual "OpenScape 4000, IP Solutions - IPDA&APE").

IMPORTANT: The factory setting for the CSPCI shelf's power supply coding is always set to ACPCI. To use DC power supplies (DCPCI), you must change the coding according to [Figure 56](#).

1) Coding of power supplies:

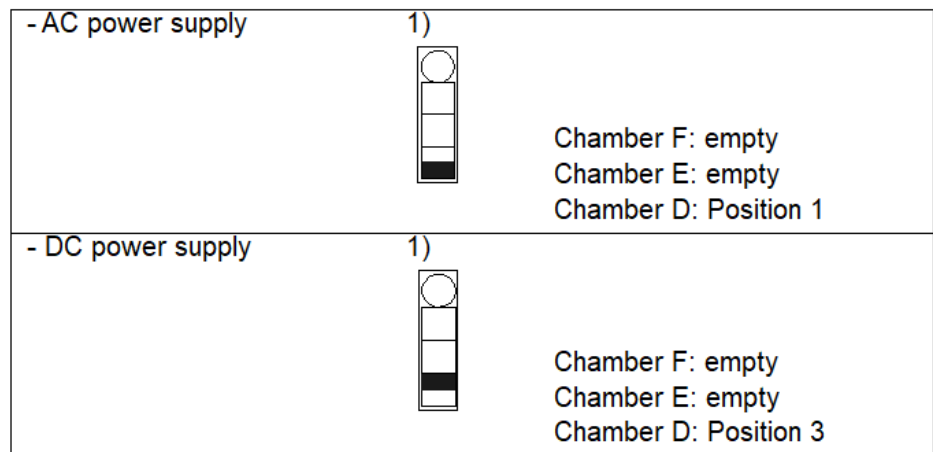

Figure 87: Coding for power supply configurations ACPCI/DCPCI

[Figure 52](#) shows the Front View of AP 3700 IP

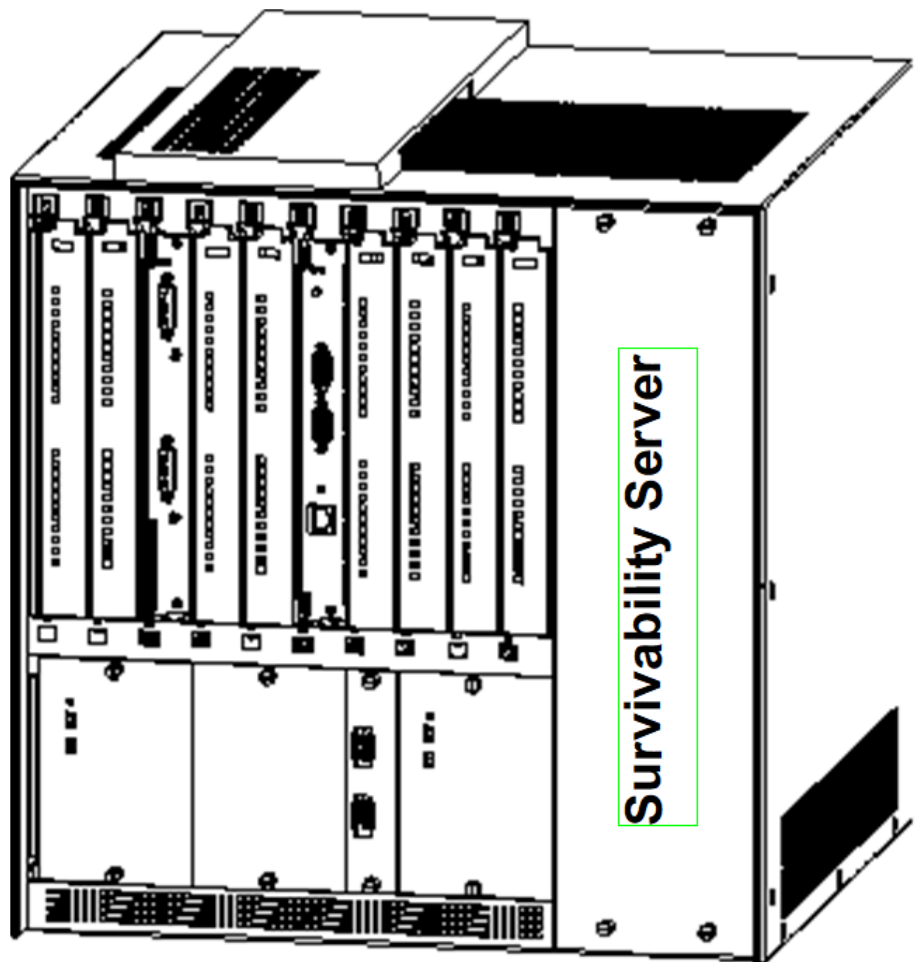

Figure 88: AP 3700 IP Front View

Figure 58 shows the Slot for Survivability Server

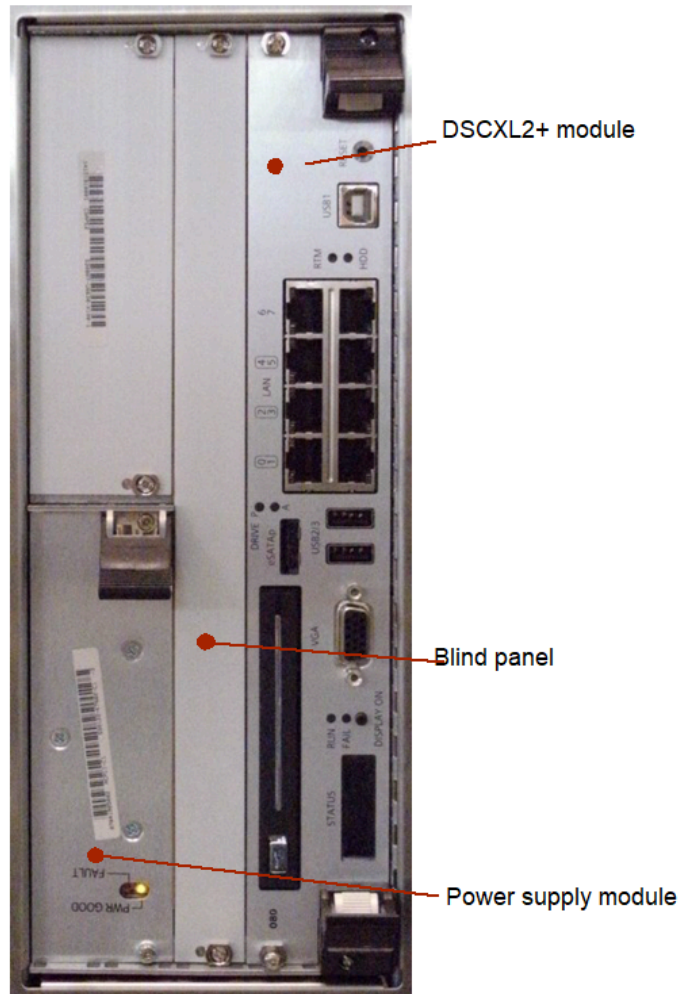

Figure 89: Survivability Server Slot

9.2 Boards

- 1) A list containing all released boards can be found on the OpenScape 4000 Product Homepage under the Intranet or via Partner Portal ("Documents -> Presales").

9.2.1 DIU2U

This section describes the functions and features of the Digital Interface Unit 2 Universal (DIU2U) board. It also provides procedures for removing, replacing, and verifying this board.

9.2.1.1 Functional Description

The DIU2U board (see [Figure 59](#)) supports two T1 spans for ISDN PRI and CorNet-VN functions (Message Oriented Signaling [MOS]) and (CorNet-VN). Any combination of MOS and CVN can be supported by the two T1 spans.

The DIU2U board can also be used for the analog emulation function (Bit Oriented Signaling [BOS]). Only one span, Line 1, is used to support the BOS circuits such as T1 trunks and tie lines. Line 2 is not functional when line 1 supports BOS..

9.2.1.2 Hardware

It has two interfaces (see [Figure 59](#)) that connect to adapter cables ([Figure 60](#)).

The adapter cables connect to a T1 customer service unit (CSU) or data service unit (DSU). With this cable, Line 1 pairs are the same as those of the TMDNH board, pair 13 transmit and pair 16 receive.



Figure 90: DIU2U Board, Front Panel

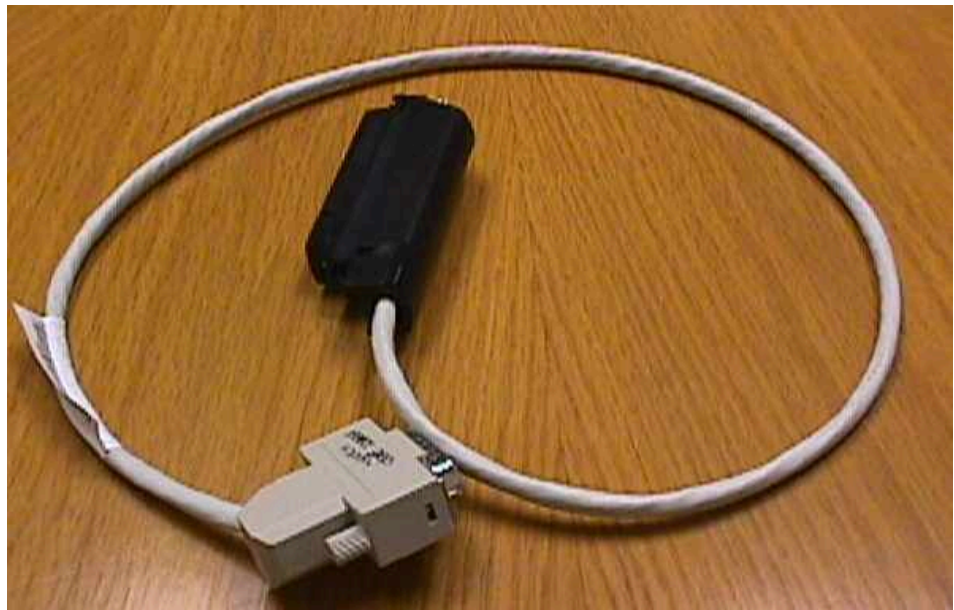
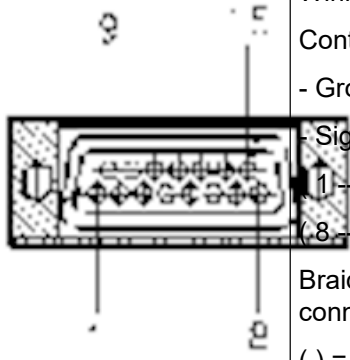
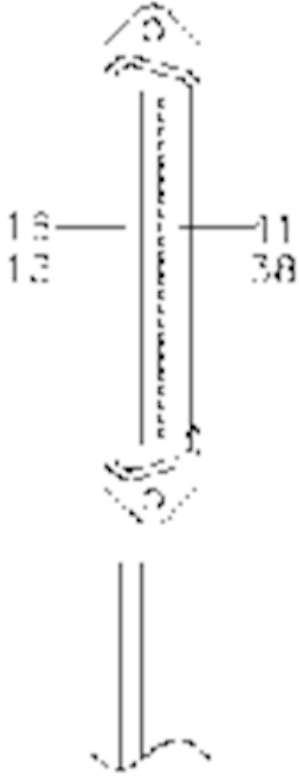

Figure 91: T1 CSU or DSU Cable

Detailed Cable Description T1 Cable

Part number: C39195-A7269-Bxxx

Table 56: T1 Cable pinout

Connector 1	Connection	Connector 2
 <p>SubD, 15 pos. / male Cable outlet: diagonal Fastening: Screw</p>	<p>Wiring mode: 1 - 1 Contacts: 4 - Ground: n/c - Signals: 1 --- 13, 9 --- 38) (8 --- 16, 15 --- 41) Braided shield connected () = Twisted pairs</p>	 <p>Champ, 50 pos. / male Cable outlet: 90 Degree Fastening: Screw</p>
<p>Material:) Round-cable, solid conductor, 2 twisted pair, 24 AWG ,UL Category 5; braided shield+ foil shield , Length: 0.7M</p>		

9.2.1.3 LED Indications

Table 44 lists the LED indications for the DIU2U board.

Table 57: DIU2U Board LED Indications

Red LED State	Green LED State	Indication
On	Off	The board has initial power applied.
Flashing	Off	The board is being loaded with loadware.
On	Off	The board is defective or out-of-service.

Red LED State	Green LED State	Indication
Off	On	The board is operational and all channels are inactive.
Off	Flashing	The board is operational and one or more channels are active.

The DIU2U board does not provide the red and yellow line status LED indications which are present on the TMDNH board. However, AMO DIS-PETRA (address FFFF:FFFC, count 0) can be used to display the line status LED indications. Refer to [Section 8.2.1.4, "Configuring the DIU2U Board", "AMO-PETRA"](#).

9.2.1.4 Configuring the DIU2U Board

The following AMOs are used to identify, display, and configure the DIU2U board:

- AMO BGDAT
- This AMO lists the available function identifications (FCTID), the number of circuits, line types and the location of the loadware.
 - FCTID 5 is for BOS circuits, that is. T1 ground start or T1 tie lines.
 - FCTID 6 is for MOS and CVN (CorNet VN), that is Primary Rate or CorNet NQ.

The BOS CIRCUITS quantity is 25. For a BOS configuration, each circuit or channel is configured with AMO TACSU.

The MOS CIRCUITS quantity is 2. Each Primary Rate Span is configured with AMO TDCSU.

```
DIS-BGDAT:Q;
H500: AMO BGDAT STARTED
UEGDAT BOARD TABLE
POS Q-NUMBER TYPE BD-NAME FCTID CIRCUITS LINE-TYPE LW-
FILE
=====
079 Q2216-X TMD DIU2U-B 5 25 TMDN_BOS LG82/PZFDUNBK
080 Q2216-X TMD DIU2U-M 6 2 TMDN_MOS_CVN LG82/PZFDUNMK
```

- AMO BCSU

ADD-BCSU

Adding a DIU2U board

IMPORTANT: Parameter LWPARG is not used when adding line type MOS.

BOS type circuits for North America Installation

```
ADD-BCSU: MTYPE=TMD, LTG=1, LTU=<1-99>, SLOT=<25-121>,
PARTNO="Q2216-
X", FCTID=5, LWVAR="K", LWPARG=<1-200>, FIDX=1, HWYBDL=A;
```

(Adding a DIU2U to shelf 2 slot 31)

```
ADD-BCSU: MTYPE=TMD, LTG=1, LTU=2, SLOT=31, PARTNO="Q2216-
X", FCTID=5, LWVAR="K", LWPARG=1, FIDX=1, HWYBDL=A;
```

MOS type circuits for North America Installation.

```
ADD-
BCSU: MTYPE=TMD, LTG=1, LTU=<1-99>, SLOT=<25-121>, PARTNO="Q2216-
X ", FCTID=6, LWVAR="K", HWYBDL=A;
```

(Adding a DIU2U to shelf 2 slot 37)

```
ADD-BCSU: MTYPE=TMD, LTG=1, LTU=2, SLOT=37, PARTNO="Q2216-
X", FCTID=6, LWVAR="6", HWYBDL=A;
```

CHA-BCSU

This AMO allows changing a TMDNH board to a DIU2U board for a BOS line type.

```
CHA-BCSU: TYPE=PARTNO, LTG=1, LTU=8, SLOT=55, PARTNO1="Q2192-
x", PARTNO2= "Q2216-X", FCTID1=1, FCTID2=5;
```

IMPORTANT: Changing a TMDNH board to a DIU2U board for a MOS line type is not possible.

DIS-BCSU

This AMO shows the assigned loadware table index (LWPARG). The display for a MOS type only shows the first line or span of the DIU2U board. To read the first or second line of the DIU2U, use AMO TDCSU.

```
DIS-BCSU: TYPE=MODE, LTG=1, LTU=2, SLOT=31;
ADDRESS | ASSIGNED MDL | TYPE | MODE
-----+-----+-----
+-----+
1. 2. 31 | Q2216-X | BOS | LWPARG: 1 FIDX: 1
AMO-BCSU -111 BOARD CONFIGURATION, SWITCHING UNIT
```

```
DIS-BCSU: TYPE=MODE, LTG=1, LTU=2, SLOT=37
ADDRESS | ASSIGNED MDL | TYPE | MODE
-----+-----+-----
+-----+
1. 2. 37 | Q2216-X | MOS-CVN | LWPARG: 3
```

- AMO LWPARG

CHA-LWPARG

When adding a DIU2U board for a BOS circuit, the LWPARG parameter is required.

The following example shows a BOS circuit for extended superframe format with binary eight zero substitution.

```
CHANGE-LWPARG:
  TYPE=TMD, TMDTYPE=TMDBOS, BLNO=1, OPMODE=FRAMEESF&BISUB8ON&BDETON;
```

The following example shows a MOS circuit for a WORLDCOM/MCI primary rate span

```
CHANGE-LWPARG: TYPE=TMD, TMDTYPE=TMDMOS, BLNO=3,
  OPMODE=FRAMEESF&BISUB8ON&BDETON, CABLETYP=1, CRIDC=0222;
```

DIS-LWPARG

```
DIS-LWPARG: TYPE=TMD, TMDTYPE=TMDMOS, BLNO=3;
```

```
+-----+
+
| BLOCK TYPE TMDN64 OPMODE: MOS BLNO : 3 |
+-----+
+
| OPMODE: FRAMEESF: [X] BISUB8ON: [X] BDETON : [X] |
| TABSON : [ ] NETUSER : [ ] TIMLOOP: [ ] |
| OESDISTH : 30 OESREQTH: 4 |
| SESDISTH : 10 SESREQTH: 10 CABLETYPE: 1 |
| ACKTIM : 10 DLVTIM : 300 WINDOW : 7 |
| OCTMAX : 260 RETMAX : 3 CRIDC : 0222 |
| NSFIV : 1 NSFTTSC : 9 TTSC : 4 |
+-----+
+
```

- AMO TACSU

For adding circuits for conventional T1 circuits (GRDSTR, LPSTR, T1TIE, etc.), each channel needs to be configured. This is the same as all previous released TMDH or TMDHN boards.

- AMO TDCSU

ADD-TDCSU

The first line on the DIU2U of a MOS trunk type gets the PEN parameter CCT value of "0" and the second line gets a value of "1"

```
ADD-TDCSU: OPT=NEW, PEN=<ltg-ltu-slot-cct>
```

CHA-TDCSU

The following example shows the required parameters to change the LWPARG block number for a CorNet-VN circuit on the second circuit of the DIU2U board.

```
CHA-TDCSU: PEN=1-2-37-1, DEV=S1CVN, LWPARG=2, BCGR=1;
DIS-TDCSU
```

The following example shows both circuits of a DIU2U. The first circuit is CorNet-N and the second circuit is a CorNet-NQ.

```
DIS-TDCSU: 1-2-79;
H500: AMO TDCSU STARTED
DIGITAL TRUNKS (FORMAT=S)
DEVICE PEN BCGR B-CHANNEL TGRP CCT
-----
S1CONN 1-02-079-0 1 1 && 23 66 CORNUS-V66
```

S1CONN 1-02-079-1 1 1 && 23 201 DIU2U CORNET

• AMO-REFTA

AMO TACSU and TDCSU automatically add the DIU2U to the REFTA table. When T1OPS circuits are added with AMO SCSU, the DIU2U board are not added to the REFTA table. This must be done manually with AMO REFTA.

```
ADD-
REFTA:TYPE=CIRCUIT,PEN=1-2-61-0,PRI=0,BLOCK=N,READYASY=N;
DIS-REFTA
```

The following example shows the DIU2U BOS used for T1OPS

```
DIS-REFTA:TYPE=CIRCUIT,PEN=1-2-61-0;
+-----+
+
| R E F E R E N C E C L O C K C I R C U I T S |
+-----+-----+-----+-----+-----+-----+
+-----+-----+-----+
| PEN | MODULE | DEVICE | PRI|ERROR | BLOCK | SUPP. | READY|
SRCGRP|
| | | | | | | |BUT | |
| | | | | | | |ASYN.| |
+-----+-----+-----+-----+-----+-----+
+-----+-----+-----+
| 1- 2- 61- 0 | DIU2-B | | 0| 00000| N | | N | 1|
+-----+-----+-----+-----+-----+-----+
+-----+-----+-----+

```

The following example shows a DIU2U MOS used for two NI2 spans

```
DIS-REFTA:TYPE=CIRCUIT,PEN=1-2-85;
+-----+
+
| R E F E R E N C E C L O C K C I R C U I T S |
+-----+-----+-----+-----+-----+-----+
+-----+-----+-----+
| PEN | MODULE | DEVICE | PRI|ERROR | BLOCK | SUPP. | READY|
SRCGRP|
| | | | | | | |BUT | |
| | | | | | | |ASYN.| |
+-----+-----+-----+-----+-----+-----+
+-----+-----+-----+
| 1- 2- 85- 0 | DIU2-M | S1COD | 0| 0| N | | N | 1|
| 1- 2- 85- 1 | DIU2-M | S1COD | 0| 0| N | | N | 1|
+-----+-----+-----+-----+-----+-----+
+-----+-----+-----+

```

- AMO-PETRA

The two LEDs on the top of the board faceplate show the status of the board itself. Refer to [Section 8.2.1.3, "LED Indications"](#).

DIS-PETRA

AMO PETRA is used to read the status of each line to determine if they are in red alarm, yellow alarm or active at layer three.

[Table 45](#) lists the generic indications for the red and yellow line status LEDs.

Table 58: Line Status LED Indications

Line LED (Red)	Line LED (Yellow)	Indication
Off	Off	Indicate the span is in Green state, layer 1 is active and possibly higher layers (layer 2 and layer 3) are also active.
Off	On	Indicates that the far end is in Loss of Frame alarm state and is unable to synchronize on its incoming signal. The far end is transmitting Remote Alarm Indication (RAI)
On	Off	Indicates that the near end is in the Loss of Frame alarm state (red or blue) and is unable to synchronize on the incoming signal.
On	Off	Indicate that the span is not configured or is disabled by the switching unit.

The following example shows the status of a DIU2U set up as BOS. In the right column, the DIU2U board state is GREEN. For the first circuit or Line 1 of the board, the "OFF" status means the circuit is active in Layer 3. For Line 2, "RED YELLOW" means that there are no circuits data based. Since this is a BOS type board, Line 2 is not available for use.

```
DIS-
PETRA:TYPE=DUMP,LTG=1,LTU=2,SLOT=31,CPU=86,SEG=FFFF,ADR=FFFC;
H500: AMO PETRA STARTED
F11: BOARD HAS NO DUMP FUNCTION
ALTHOUGH SEND THE COMMAND TO THE PERIPHERAL MODULE? (Y/N)
*y
DUMP FOR LTG 1 LTU 2 SLOT 31
FFFF:FFF0 20 20 20 20
FFFF: 0 43 41 52 44 20 4C 45 44 20 53 54 41 54 45 20 20
CARD LED STATE
FFFF: 10 20 20 47 52 45 45 4E 20 4F 4E 20 20 20 20 20 20
GREEN ON
FFFF: 20 4C 49 4E 45 20 4C 45 44 20 53 54 41 54 45 20 20
LINE LED STATE
FFFF: 30 20 20 31 20 4F 46 46 20 20 20 20 20 20 20 20 20
1 OFF
```

```
FFFF: 40 20 20 32 20 52 45 44 20 59 45 4C 4C 4F 57 20 20
      2 RED YELLOW
```

The following example shows the DIU2U board set up as MOS and both circuits are in use, Line 1 is at layer 3 and Line 2 is in red alarm.

```
DIS-
PETRA:TYPE=DUMP,LTG=1,LTU=2,SLOT=37,CPU=86,SEG=FFFF,ADR=FFFC;
H500: AMO PETRA STARTED
F11: BOARD HAS NO DUMP FUNCTION
ALTHOUGH SEND THE COMMAND TO THE PERIPHERAL MODULE? (Y/
N)
*y
DUMP FOR LTG 1 LTU 2 SLOT 37
FFFF:FFF0 20 20 20 20
FFFF: 0 43 41 52 44 20 4C 45 44 20 53 54 41 54 45 20 20
      CARD LED STATE
FFFF: 10 20 20 47 52 45 45 4E 20 4F 4E 20 20 20 20 20 20
      GREEN ON
FFFF: 20 4C 49 4E 45 20 4C 45 44 20 53 54 41 54 45 20 20
      LINE LED STATE
FFFF: 30 20 20 31 20 4F 46 46 20 20 20 20 20 20 20 20 20
      1 OFF
FFFF: 40 20 20 32 20 52 45 44 20 20 20 20 20 20 20 20 20
      2 RED
AMO-PETRA-111 PERIPHERY TRACING AND DUMPING
DISPLAY COMPLETED;
```

9.2.1.5 Removing the DIU2U Board

IMPORTANT: This procedure removes all the channels on this trunk board from service.

NOTICE: Static Sensitive Devices! Observe all precautions in for electrostatic discharge.

Remove the DIU2U board as follows:

IMPORTANT: For ISDN applications, first deactivate the B channels, and then deactivate the D channel.

1) Deactivate all channels as follows:

- a) Type DEA-DSSU and press Enter.
- b) Type the following values, then press Enter.

Field	Value
OFFTYPE	DC
TYPE	PEN
PEN1	<PEN1>

PEN2 <PEN2>

IMPORTANT: PEN1 is the PEN of the first channel and PEN2 is the PEN of the last channel on the board.

2) Deactivate the board as follows:

- a) Type `DEA-BSSU` and press Enter.
- b) Type the following values, then press Enter.

Field	Value
OFFTYPE	DC
LTG	<1 - 32>
LTU	<1 - 8>
SLOT	<1 - 151>
REFOFF	<blank>

The board is deactivated when the yellow LED is lit and the other LEDs are off.

3) Before removing the board, ensure that the red board status LED is lit, remove the board.

If the red board status LED does not light within 30 seconds, repeat steps [2a](#) and [2b](#). If the red board status LED still does not light within 30 seconds, remove the board.

9.2.1.6 Replacing the DIU2U Board

Replace the DIU2U board as follows:

- 1) Slide the board into the appropriate slot until it seats firmly into the backplane connector.
- 2) Activate the board as follows:

- a) Type `ACT-BSSU` and press Enter.
- b) Type the following values, then press Enter.

Field	Value
ONTYPE	AUL
LTG	<1 - 32>
LTU	<1 - 8>
SLOT	<1 - 151>

IMPORTANT: For ISDN applications, first activate the D channel, and then activate the B channels.

Activate the channels as follows:

- a) Type `ACT-DSSU` and press Enter.
- b) Type the following values, then press Enter.

Field	Value
ONTYPE	AUL
TYPE	PEN
PEN1	<PEN1>
PEN2	<PEN2>

IMPORTANT: PEN1 is the PEN of the first channel and PEN2 is the PEN of the last channel on the board.

9.2.1.7 Verifying the DIU2U Board

To verify the operation of the DIU2U board, confirm that the green LED turns on.

9.2.2 DIU-N2 / DIU-N4

IMPORTANT: With HiPath 4000 V4 the DIUN4 board (Q2195) is not supported any longer. Only the DIUN2 board will be supported.

In this section, the digital interface unit ISDN (DIU-N2 and DIU-N4) boards are going to be called DIU-Nx. These boards are designed to connect to public and private E1 and T1 (DIUN4 only) networks and subscribers. Also, the boards fulfill the Nx64Kbit feature. The DIU-Nx has two/four line-interfaces (ports). If the LTUW shelf use the LTUCX board, then the DIU-Nx can choose between the old or the new PCM highways. If the LTUW shelf use the LTUCE board, then the DIU-Nx is connected to the old PCM highways.

Figure 61 shows a functional diagram of the DIUN2 or DIUN4 board.

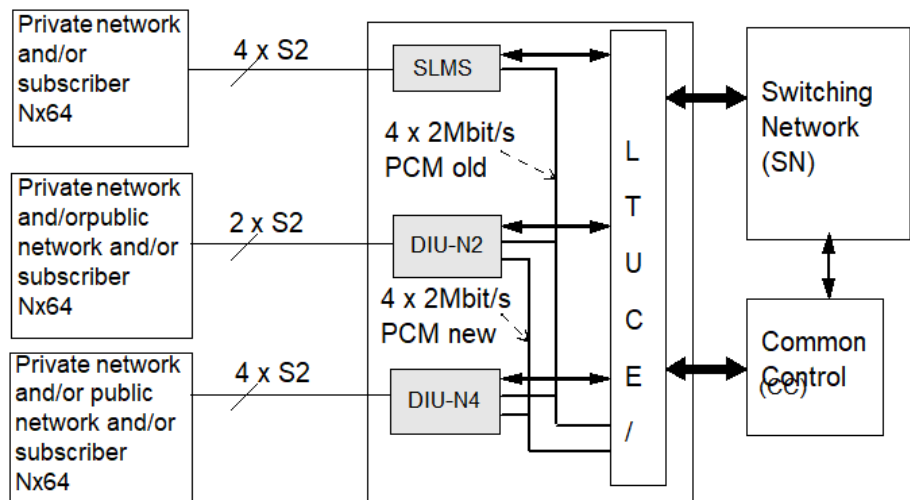

Figure 92: DIUN2 or DIUN4 Functional Diagram

Following features are available:

Number of ports:

- DIU-N2 2ports
- DIU-N4 4ports (not for DIU-C)

Type of connection:

- Fiber optical interface
- 75 Ohm copper interface

- 100 Ohm copper interface (DIU-N4 only)
- 120 Ohm copper interface
- Receive clock recovery for network mode on all ports

At the DIU-N2 (DIU-C) an optical line access is available at FRONT or BACK. The copper line access is possible at FRONT only.

At the DIU-N4 the optical and copper line access is possible at FRONT only.

To link the optical fibers to the front panel, three new adapter modules (AMOM) are used.

9.2.2.1 LED indications

The front panel contains 2 LEDs.

The DIU-Nx has a red and a green LED to support LED service strategy. The control output of the red LED is additionally used for signaling results of the on-board self test. The output (TOUT) is, in parallel, connected to a pin of the board plug. The signal is active low.

9.2.2.2 Board Variants

- DIU-N2 S30810-Q2196-X
- DIU-N4 S30810-Q2195-X

The following types of adapter modules are available:

- AMOM S30807-K5480-X100 850nm, multi mode
- AMOM S30807-K5480-X200 1300nm, multi mode
- AMOM S30807-K5480-X300 1300nm, single mode

9.2.2.3 Board Functions

DIU-N2

The DIU-N2 provides two types of optical line interfaces. It is possible to access either all two ports through the old backplane interface or through the new optical interface at the front panel of the board (15-pin Sub-D). Only one of these two interfaces is activated by the LW at a time. After a reset, the optical interface at the backplane connector becomes active. It is possible to use either Multimode- or Monomode optical fibers.

- Line access

If the optical interface on the backplane is chosen then the ports #0 and #1 are accessible by means of the old adapters APCFM and APCFL only (S30807-Q5446 and S30807-Q5422).

The DIU-N2 does not use the APCFM/L in mixed mode.

IMPORTANT: Do not connect copper cable with port #1 of the adapter.

- If the optical interface at the front panel is used, the ports are accessed through an optical/electrical converter AMOM connected to the 15-pin Sub-D. mono mode or multi mode optical fibres can be used.

DIU-N4

The DIU-N4 has one optical interface for every port, which can be accessed through the 15-pin Sub-D connector at the front panel of the board.

9.2.2.4 Copper interface

Two pairs of lines represents the physical interface of each port of the DIU-Nx board; one pair the receive and one pair the transmit direction.

- Line access
 - To connect copper lines to the ports of the DIU-Nx, the 2/4 15-pin Sub-D connectors at the front side of the board must be used. With the DIU-N4 100Ω Impedances can additionally be handled. The selection of the appropriate line termination impedance (75Ω (LWPS=2), 120Ω (LWPS=0), 100Ω (LWPS=1) with DIU-N4) are performed by the loadware. If coaxial lines are connected, 75Ω line impedance has to be selected; for shielded-twisted-pair lines (2x2x0.6/PE, S30267-Z167), 120Ω line impedance must be used. For shielded twisted pair cables of the AT&T type 1251 or United Wire&Cable P/N 21257, the 100Ω line impedance must be selected. (DIU-N4 only). Copper lines are directly connected to the board's 15-pin Sub-Ds (without any adaptor).
 - AMO TDCSU and parameter LWPS are used to select the impedance. Line termination is set with the AMO LWPARG for the DIUC function.

It is not possible to connect copper lines to the DIU-N2 ports through the SIPAC connector of the backplane. With the DIU-N2 the adapter APCFM/L can only be used for connecting optical lines. The 9-pin Sub-M connector of this adapter is unused.

IMPORTANT: Fiber optics connected with the new AMOM adapters cannot be connected directly with the old APCFL adapter of the distant end because they operate with different standards

9.2.2.5 Connecting Variants to DIU-N2 Ports

Table 46 lists the connecting variants to the DIU-N2 ports.

Table 59: Connecting Variants to the DIU-N2 Ports

Variation number	PORT0 FRONT	PORT0 BACK	PORT1 FRONT	PORT1 BACK
1.	-	-	-	LWL
2.	-	-	LWL	-
3.	-	LWL	-	-

Variation number	PORT0 FRONT	PORT0 BACK	PORT1 FRONT	PORT1 BACK
4.	LWL	-	-	-
5.	-	-	Cu	-
6.	Cu	-	-	-
7.	Cu	-	Cu	-
8.	Cu	-	-	LWL
9.	Cu	-	LWL	
10.	-	LWL	Cu	-
11.	LWL	-	Cu	-
12.	LWL	-	LWL	-
13.	-	LWL	-	LWL

9.2.2.6 SIPAC Connector Pin Assignments

Table 47 lists the pin assignments of the SIPAC connector on the DIU-N2 board.

Table 60: SiPAC Connector Pins

Signal Name	Connector Pin	Signal Description	Direction
LWLI0_BACK	X3-04	Port 0: fiber link data input (back)	Input
LWLO0_BACK	X3-02	Port 0: fiber link data output (back)	Output
LWLCI0	X1-26	Port 0: fiber link clock in	Input
LWLCO0	X2-02	Port 0: fiber link clock out	Output
LWLLOOP	X4-04	fiber link loop	Output
LWLI1_BACK	X3-10	Port 1: fiber link data input (back)	Input
LWLO1_BACK	X4-02	Port 1: fiber link data output (back)	Output
LWLCI1	X4-26	Port 1: fiber link clock in	Input
LWLCO1	X4-06	Port 1: fiber link clock out	Output

9.2.2.7 Sub-D Connectors X21 and X22 Pin Assignments

Table 48 lists the pin assignments for the sub-D X21 and X22 connectors.

Table 61: Sub-D X21 and X22 Connectors Pin Assignments

Signal name	Connector pin	Signal description	Direction
RTIP0	X21-8	Port 0: TIP 120Ω / 75Ω	Input
RRING0	X21-15	Port 0: RING 120Ω/ 75Ω	Input
TTIP0	X21-1	Port 0: TIP 120Ω / 75Ω	Output
TRING0	X21-9	Port 0: RING 120Ω/ 75Ω	Output
LWLI0_FRONT	X21-11	Port 0: fiber link data input (front)	Input
LWLO0_FRONT	X21-4	Port 0: fiber link data output (front)	Output
+5V	X21-10; X21-14	+5V power supply	Output
GND	X21-5; X21-12	ground return for the +5V power supply	Input/ Output
SCAN_IN0	X21-7; X21-6	adapter check	Input
RTIP1	X22-8	Port 1: TIP 120Ω / 75Ω	Input
RRING1	X22-15	Port 1: RING 120Ω/ 75Ω	Input
TTIP1	X22-1	Port 1: TIP 120Ω / 75Ω	Output
TRING1	X22-9	Port 1: RING 120Ω/ 75Ω	Output
LWLI1_FRONT	X22-11	Port 0: fiber link data input (front)	Input
LWLO1_FRONT	X22-4	Port 0: fiber link data output (front)	Output
+5V	X22-10; X22-14	+5V power supply	Output
GND	X22-5; X22-12	ground return for the +5V power supply	Input/ Output
SCAN_IN1	X22-7; X22-6	adapter check	Input

9.2.2.8 Sub-D line interface connectors X23 and X24 Pin Assignments

Table 49 lists the pin assignments for the Sub-D line interface X23 and X24 connectors.

Table 62: Sub-D line interface X23 and X24 Connectors Pin Assignments

Signal name	Connector pin	Signal description	Direction
RTIP2	X23-8	Port 0: TIP 120Ω / 75Ω	Input
RRING2	X23-15	Port 0: RING 120Ω/ 75Ω	Input
TTIP2	X23-1	Port 0: TIP 120Ω / 75Ω	Output
TRING0	X23-9	Port 0: RING 120Ω/ 75Ω	Output
LWLI0_FRONT	X23-11	Port 0: fiber link data input (front)	Input
LWLO0_FRONT	X23-4	Port 0: fiber link data output (front)	Output
+5V	X23-10; X23-14	+5V power supply	Output
GND	X23-5; X23-12	ground return for the +5V power supply	Input/ Output
SCAN_IN0	X23-7; X23-6	adapter check	Input
RTIP1	X24-8	Port 1: TIP 120Ω / 75Ω	Input
RRING1	X24-15	Port 1: RING 120Ω/ 75Ω	Input
TTIP1	X24-1	Port 1: TIP 120Ω / 75Ω	Output
TRING1	X24-9	Port 1: RING 120Ω/ 75Ω	Output
LWLI1_FRONT	X24-11	Port 0: fiber link data input (front)	Input
LWLO1_FRONT	X24-4	Port 0: fiber link data output (front)	Output
+5V	X24-10; X24-14	+5V power supply	Output
GND	X24-5; X24-12	ground return for the +5V power supply	Input/ Output
SCAN_IN1	X24-7; X24-6	adapter check	Input

9.2.2.9 Configuring the DIU-N2 Board Using AMOs

To configure the DIUN2 board, use the following AMOs:

- AMO TDCSU-configures the trunk assignment

- AMO LWPARG-configures the following loadware parameter specifications:
 - With/without CRC4 in the TSL0
 - Layer 2 master/slave setting
 - Line interface Copper/Fiber (HDB3/NRZ)
 - Reference clock activation
 - LAPD in TSL
 - IDLE CHANNEL CODE
 - Deactivation and message times
- AMO REFTA-configures the reference clock table specification (PRI 0 - 90)
- AMO BSSU-Displays the board statistics
- AMO BCSU-adds the new boards under the branch PER and not DIU.
- AMO PETRA-displays the memory contents of the board
 - Starts and stops trace jobs
 - Displays trace results.

9.2.3 LTUCA

The LTUCA (Line Trunk Unit Control Advanced) board (see [Figure 62](#)) is the interface between central and peripheral parts of the system. The LTUCA selects the signals from the active control unit and distributes them to the appropriate boards in the LTU shelf (LTU shelf is a general expression for all types of peripheral shelf. It can be one of the compact or extended compact shelves). The LTUCA also receives signals from the peripheral boards and transmits them to the common control.

Existing LTU cables are replaced by the new high-speed cables (HSC) (RJ45 CAT5). The signals are routed in a multiplexed data flow. This multiplex functionality is supported on the common control side of the RTM board and on the peripheral side of the LTUCA board.

Two (HSC) interfaces are provided on the LTUCA for CCA and CCB. Two additional lines are connected for broadband applications. Four RJ45 connector sockets are installed for this on the front of the LTUCA board. In this case, a maximum of only eight peripheral LTU shelves can be connected for each OpenScape 4000 system.

The LTUCA board can be integrated in the following system architecture:

- OpenScape 4000 (AP3700 19" architecture)

IMPORTANT: The LTUCA does not replace the LTUCX or LTUCE in existing systems. These boards are still used because the LTUCA is not compatible with existing processor boards.

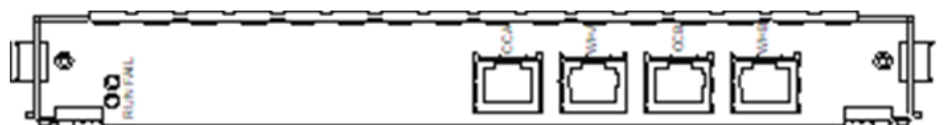

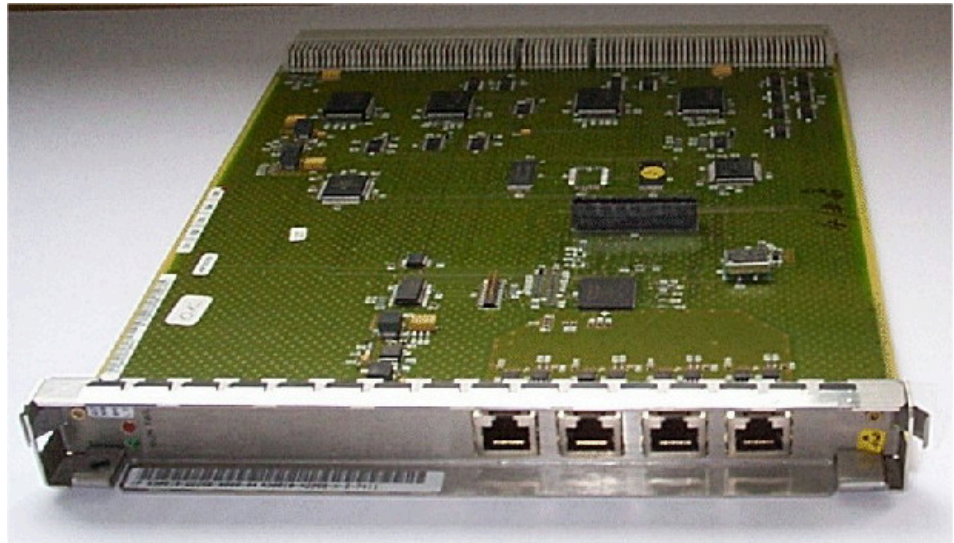

Figure 93: LTUCA Board

9.2.3.1 LEDs

The front side of the board features a green LED (RUN) and a red LED (FAIL) that indicate board status.

9.2.3.2 Hardware Part Number

S30810-Q2266-X-*

9.2.3.3 Use in Extended Shelves

The LTUCA board can be used in the following extended shelves:

LTUW: S30804-B5367-X/B5385-X and B5388-X

L80XF: S30804-B5379-X and B5389-X

L80XW: S30804-B5366-X

AP3700: S30807-U6620-X

9.2.3.4 Cable Types

The following CAT 5 RJ45 cable types are available for connecting the LTU shelf:

C39195-Z7211-A20	, 2 m	twisted cable, 10BT (RJ45)
C39195-Z7211-A50	, 5 m	twisted cable, 10BT (RJ45)
C39195-Z7211-A100	, 10 m	twisted cable, 10BT (RJ45)

9.2.3.5 LTUCA Hardware Concept (Application Scenarios)

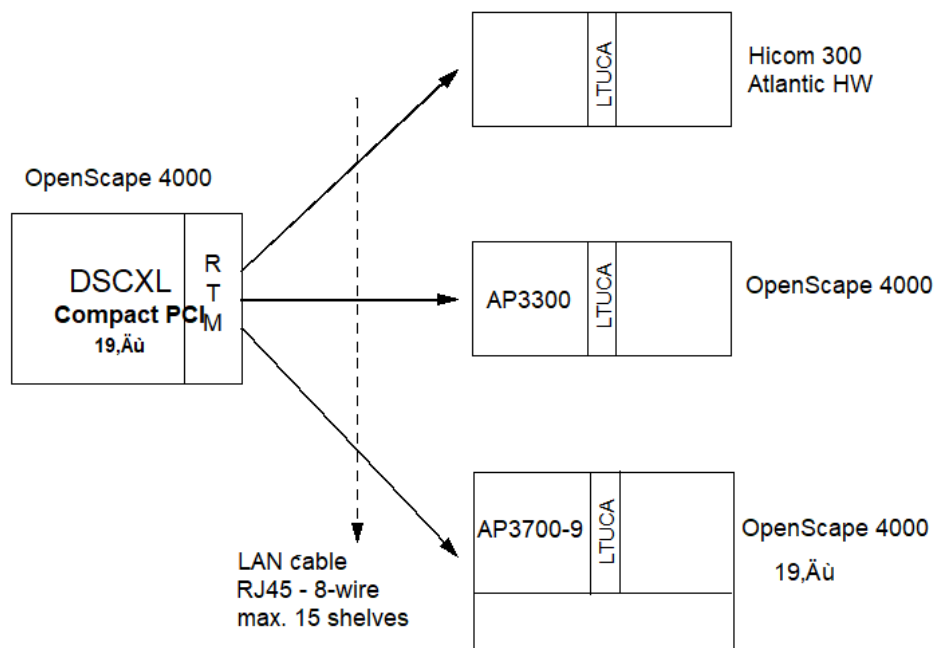

Figure 94: LTUCA Diagram for OpenScape 4000 (Example)

9.2.3.6 Power Supply

The LTUCA board receives a direct current of 5 V over the backplane. The individual voltages required (1.8 V/3.3 V) are generated by the DC/DC converter on the board.

9.2.4 NCUI2+

NOTICE: Since OpenScape 4000 V8 R1 it is possible to replace NCUI2+ by Enterprise Gateway solution. For further information about Enterprise Gateway, please refer to OpenScape 4000 V8, Enterprise Gateway, Service Documentation.

The NCUI2+ (NBCS Control Unit IP 2 HG 3575) board functions as the common control unit for the IPDA and as the gateway unit for a local system connected to a distributed PBX system. The local system could be an LTU shelf or multiple 19" cabinets. Like the LTUCA board in a peripheral shelf, the NCUI2+ controls all peripheral boards in the local system and provides access to the 10/100Base-T Fast Ethernet network. The NCUI2+ is responsible for central functions, such as DCL-LP, SIU, CONF, MTS, and CG. The board features an interface for up to sixteen peripheral boards in the LTU shelf and an interface to support a 19" system. The board communicates with the common control unit in the OpenScape 4000 over the Ethernet network. Within the local system, the NCUI2+ switches up to 256 time slots on eight highways at 2.048 Mbps.

A subset of up to 30 time slots can be switched to external traffic over the IP network.

IMPORTANT: The NCUI2+ must not be plugged in and unplugged during live operation.

Figure 64 shows the NCUI2+ board

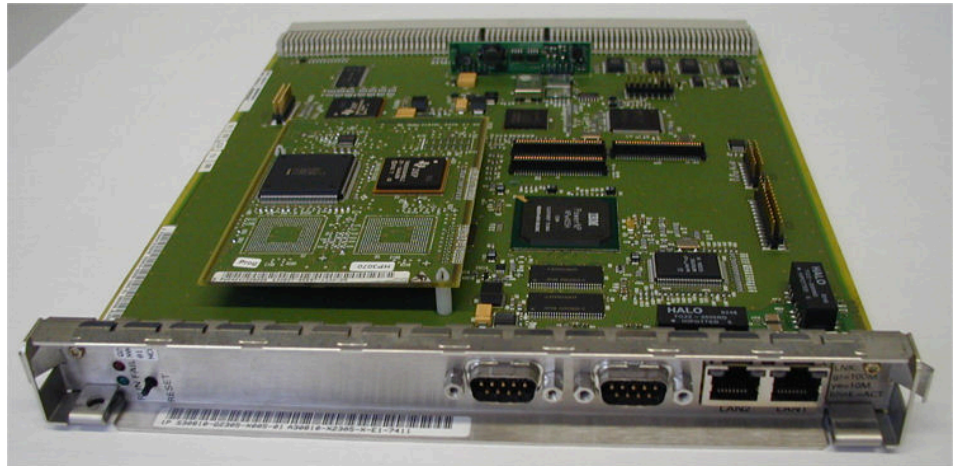

Figure 95: NCUI2+ board

9.2.4.1 System Diagram

Figure 65 shows the NCUI2+ board system diagram.

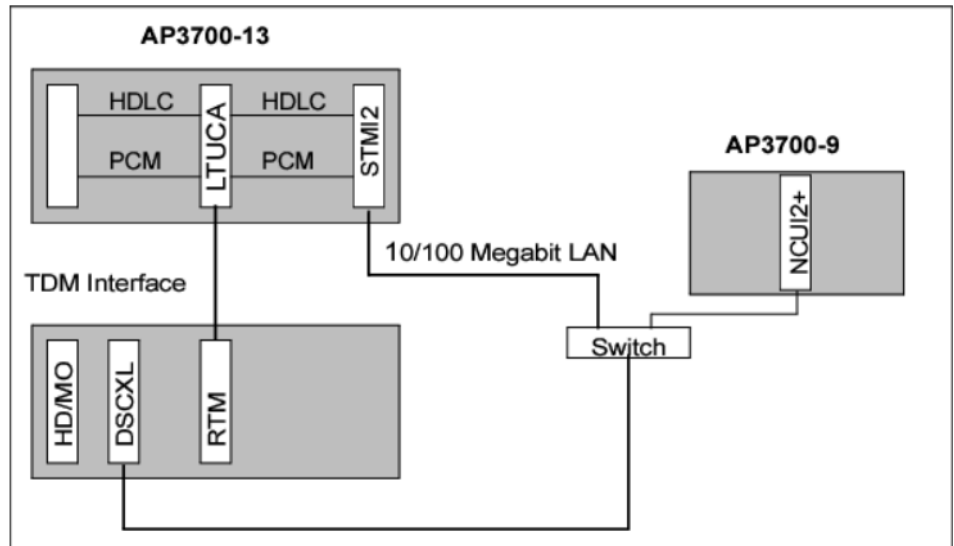

Figure 96: NCUI2+ Board System Diagram

9.2.4.2 Board Variants and Modules

NCUI2+ with an underequipped PDMX (PMC DSP Module Extended): S30810-Q2305-X35-(60-channel version)

NCUI2+ with a fully equipped PDMX (PMC DSP Module Extended): S30810-Q2305-X40-(120-channel version)

IMPORTANT: The NCUI2+ has two Gateway Accelerator slots. One is for the PDMX DSP module and the other is for an optional plug-in module (currently are not used).

PMC = PCI Mezzanine Card

9.2.4.3 LED Displays and Interfaces

Table 50 lists the LED displays and interfaces are configured on the front of the NCUI2+ board for service purposes:

Table 63: LED displays and interfaces

Quantity	LEDs and Interfaces	Functions/Indications
2	V.24 9-pin SUB-D connector	Service terminal/modem
1 each	<ul style="list-style-type: none"> Green (RUN) Red (FAIL) LED 	Board status display
1	Reset key	Reset the board
2	LEDS	For each LAN interface (integrated in the RJ45 connector) <ul style="list-style-type: none"> LED1: green/yellow green = 100 Mbps online (link) yellow = 10 Mbps online (link) flashing = active LED2: green on = full-duplex (FDX) off = half-duplex

Figure 66 shows the NCUI2+ board front panel.

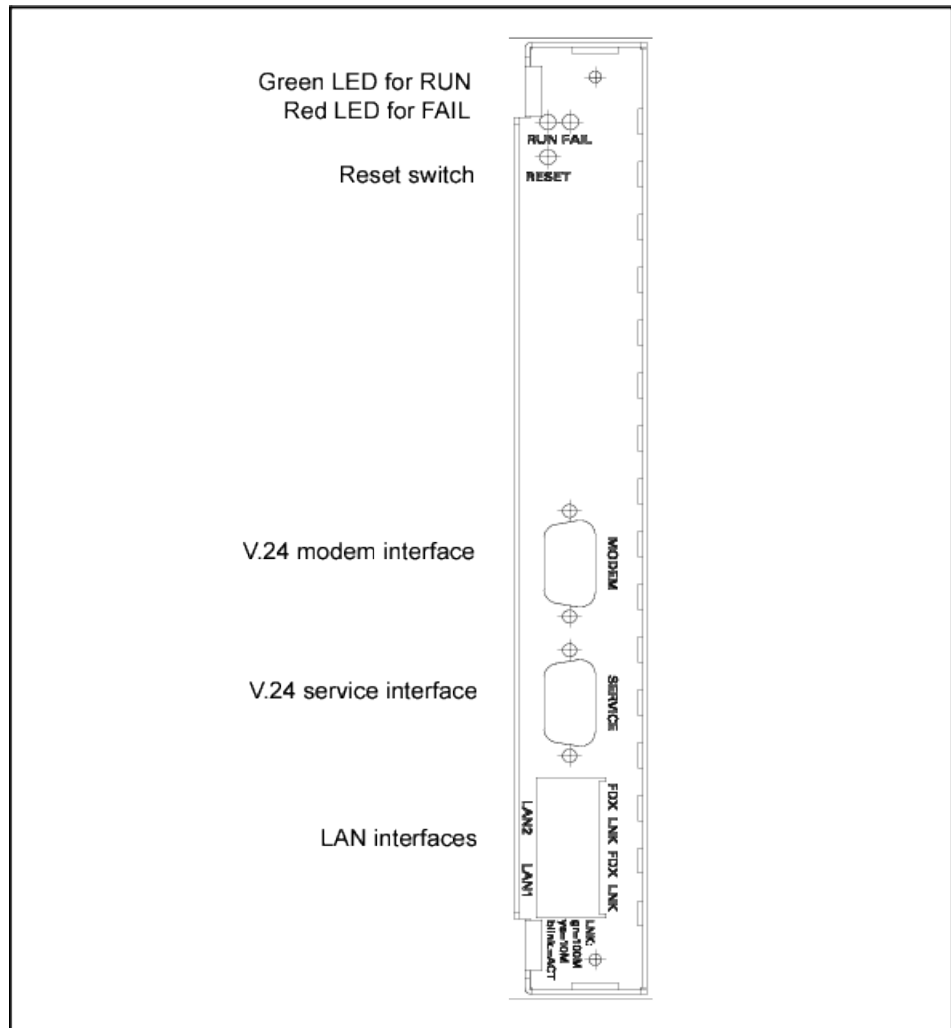

Figure 97: NCUI2+ Board Front Panel

9.2.4.4 Power Supply

The NCUI2+ board receives a power supply voltage of +5 V over the backplane. The individual voltages required (+3.3 V, +2.5 V, +1.8 V, +1.5 V, and 1.2 V) are generated by the DC-to-DC converter on the board.

9.2.4.5 Upgrade NCUI2 board

To upgrade the NCUI2 board with 64MB SDRAM/16MB Flash Memory (old) to the NCUI2+ board with 128MB SDRAM/32MB Flash Memory (new) following steps should be followed:

- 1) Connect the serial cable to the service interface panel and store board data from the old NCUI2 via CLI.

Open the Configuration IPDA menu from ComWin.

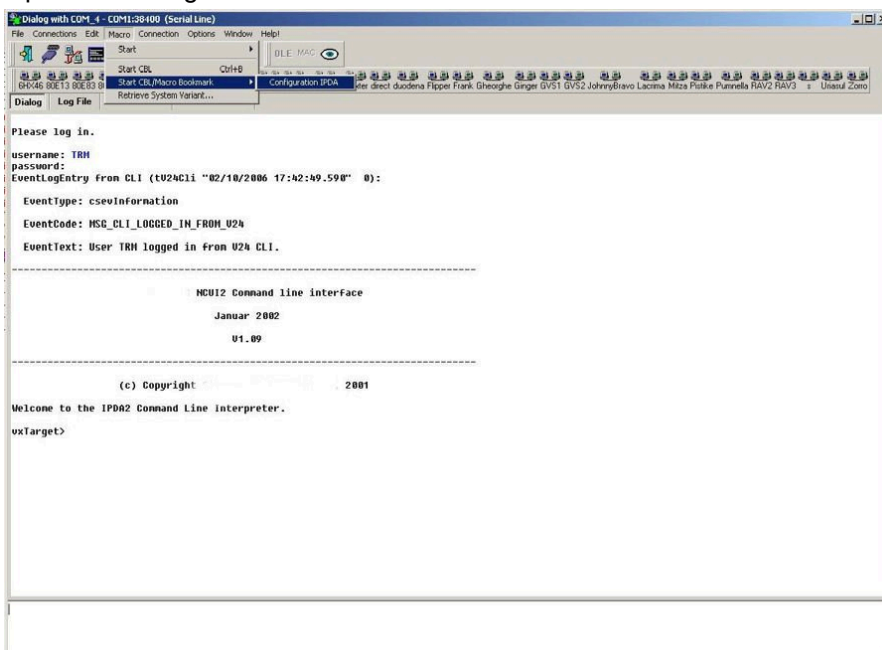

- a) Press the button Get All Parameters in order to get the data configuration from the old NCUI2 board.
- b) Press the button SAVE configuration to file and enter a name for the file where will be stored the old NCUI2 data.

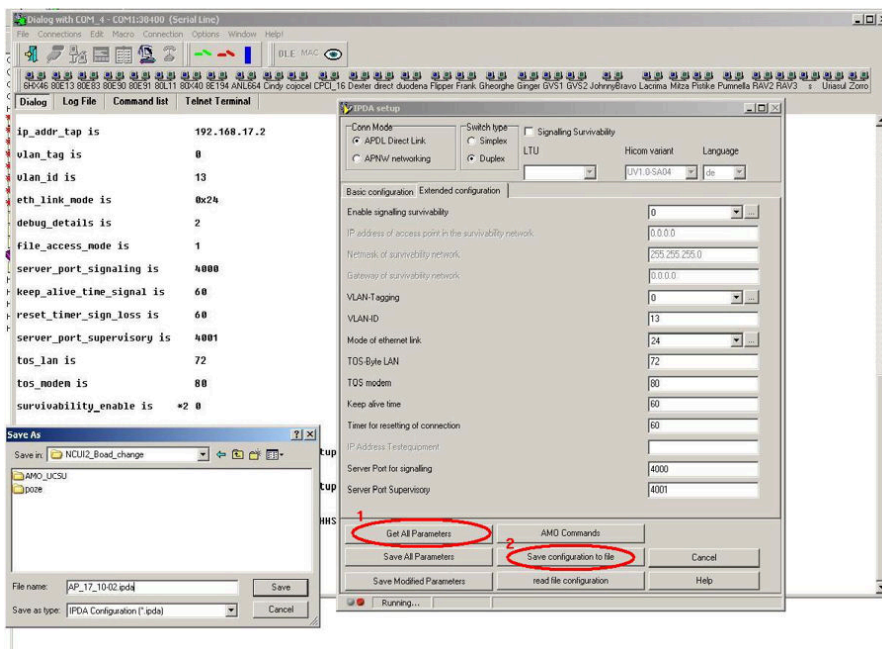

- 2) Copy via File Transfer the new version of AMO UCSU (APS: B0-EM0.10.048) in folder :PDS:APSN/S/UCSU@ (C, D and E files) and execute the RELOVL;

command

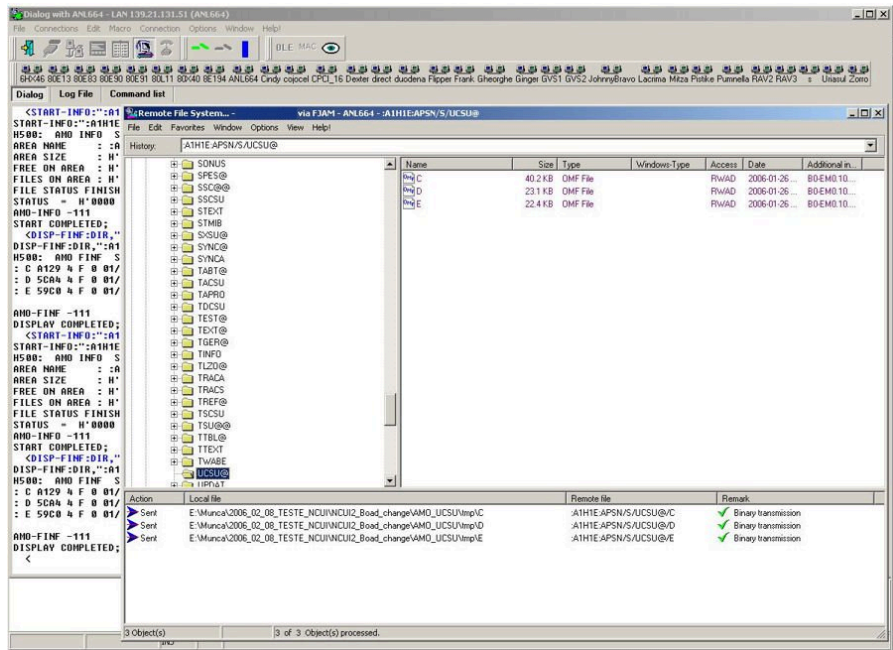

Copy the new version for the BGDAT00 file in the folder :PDS:APSU/ BGDAT00.

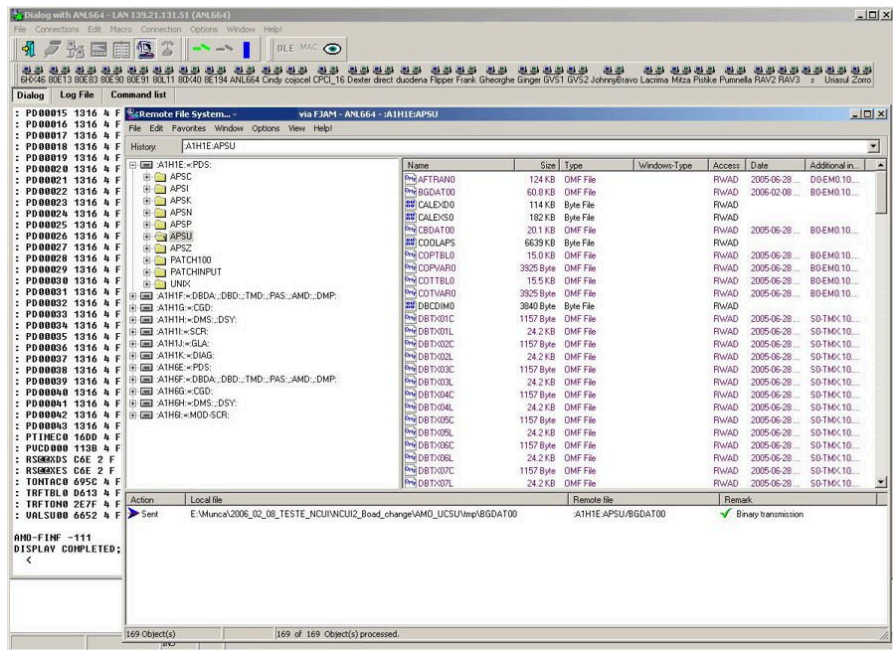

- 3) Deactivate the AP (for example AP 17)
DEACTIVATE-USSU:LTG=1,LTU=17;

Change the partnumber of the AP
CHANGE-UCSU:UNIT=AP,LTG=1,LTU=17, LTPARTNO="Q2305-X40";

- 4) Power off the AP.
- 5) Replace old NCU12 board with the new NCU12+ board.

- Copy the new LW for the new NCUI2+ board in the folder :PDS:APSP/LTG/LGA0/PZKNCI20.

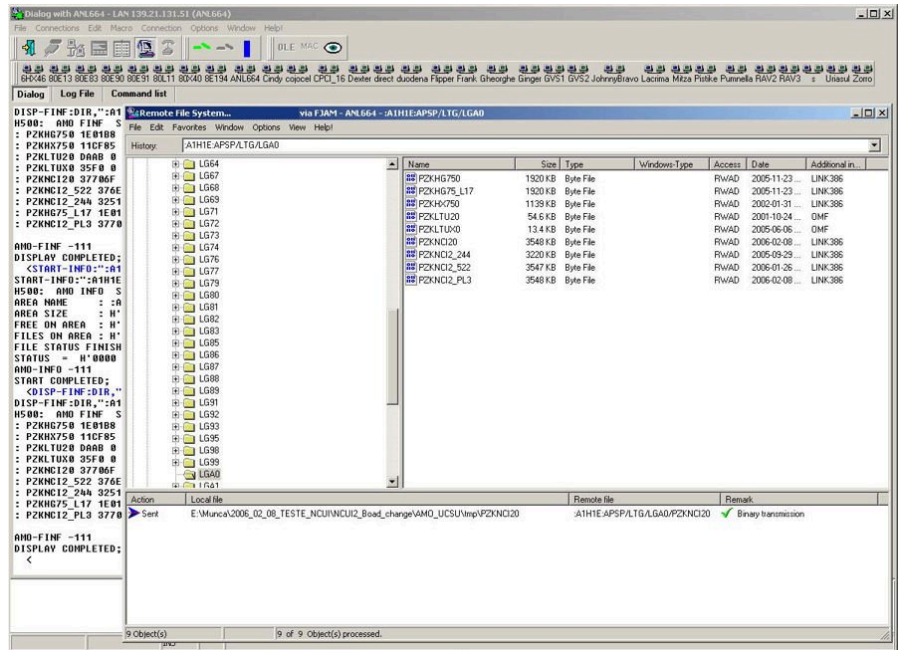

- Power on the AP.

- 8) Restore the board data saved at step 1 via CLI.
 - a) Press the button Read file configuration and select the file (saved at step 1) in order to get the NCU12 configuration data saved previous at step 1.
 - b) Press the button Save all Parameters to save the configuration data to the new NCU12+ board.

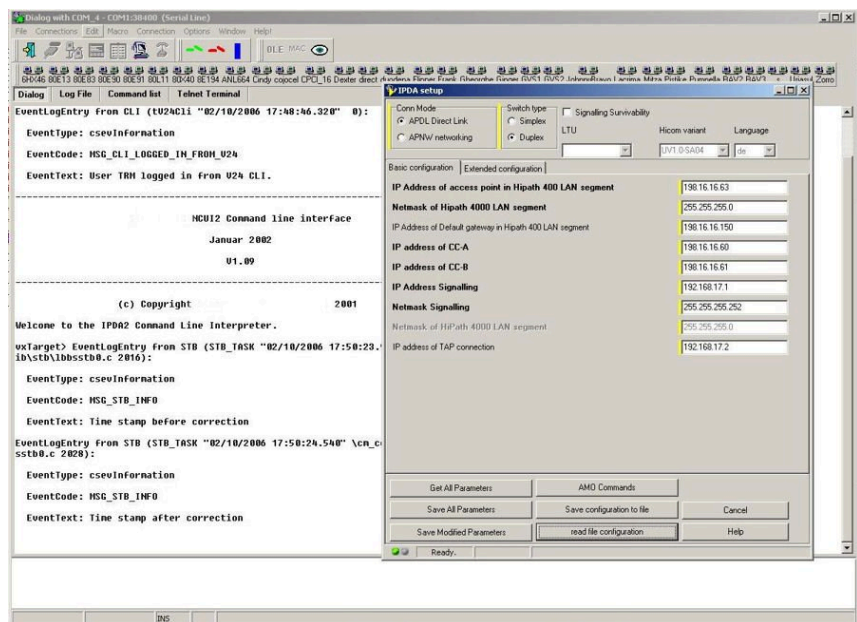
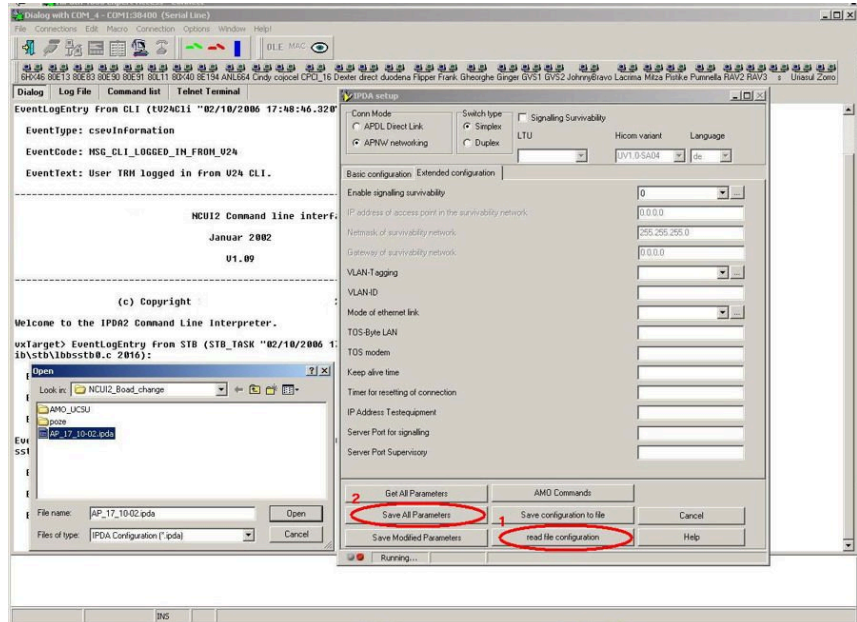

- 9) Activate the AP.
ACTIVATE-USSU:UNIT=LTG, LTG=1, LTU=17;
- 10) Verify the LW version of the board in CLI with command:
show version

CLI output:
vxTarget> show version

```

Actual loadware:
Loadware ID : 02/08/06 16:07:09 no_label pzknci20
Summary of all loadware versions:
Loadware ID : 02/08/06 16:07:09 no_label pzknci20, /
tffs/SW_IMAGE.001
Loadware file /tffs/SW_IMAGE.002 doesn't exist.
OK

```

- 11) If the board doesn't start, please reset the new NCUI board.

9.2.5 NCUI4

NOTICE: Since OpenScape 4000 V8 R1 it is possible to replace NCUI2+ by Enterprise Gateway solution. For further information about Enterprise Gateway, please refer to OpenScape 4000 V8, Enterprise Gateway, Service Documentation.

The NCUI4 (NBCS Control Unit IP 4 HG 3575) board functions as the common control unit for the IPDA and as the gateway unit for a local system connected to a distributed PBX system. The local system could be an LTU shelf or multiple 19-inch cabinets. Like the LTUCA board in a peripheral shelf, the NCUI4 controls all peripheral boards in the local system and provides access to the 100 Base-T Fast Ethernet network. The NCUI4 is responsible for central functions, such as DCL-LP, SIU, CONF, MTS and CG. The board features an interface for up to sixteen peripheral boards in the LTU shelf and an interface to support a 19-inch system. The board communicates with the common control unit in the OpenScape 4000 over the Ethernet network. Within the local system, the NCUI4 switches up to 256 time slots on eight highways at 2,048 Mbps.

IMPORTANT: The NCUI4 must not be plugged in or unplugged during live operation.

Figure 67 shows the NCUI4 board



Figure 98: NCUI4 Board

9.2.5.1 System Diagram

Figure 68 shows the NCUI4 board system diagram.

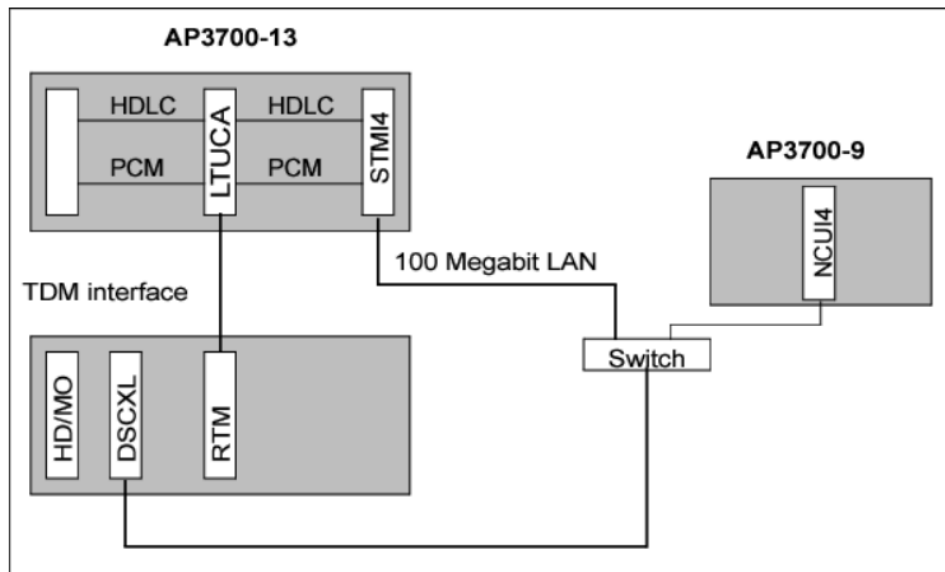

Figure 99: NCU4 Board System Diagram

9.2.5.2 Board Variants and Modules

IMPORTANT: NCU4 is replaced with combination of OpenScope Enterprise Gateway and LTUCR.

NCU4 (256 MB SDRAM/32 MB flash memory) without a PDMX (PMC DSP Module Extended): S30810-Q2324-X00 (60-channel version)

NCU4 (256 MB SDRAM/32 MB Flash Memory) with an equipped PDMX (PMC DSP Module Extended): S30810-Q2324-X11 (120-channel version)

The NCU4 features a Gateway Accelerator slot for the PDMX DSP module.

9.2.5.3 LED Displays and Interfaces

The LED displays and interfaces are configured on the front of the board for service purposes:

Table 64: LED Displays and Interfaces

Quantity	LEDs and Interfaces	Functions/Indications
2	V.24 9-pin SUB-D connector	Service terminal/modem
One each	<ul style="list-style-type: none"> Green (RUN) Red (FAIL) LED 	Board status display
1	Reset key	Reset the board

Quantity	LEDs and Interfaces	Functions/Indications
2	LEDS	For each LAN interface (integrated in the RJ45 connector) <ul style="list-style-type: none"> • LED1: green On = 100 Mbps • LED2: green Green = online (link) Wink = active

Figure 69 shows the NCUI4 board front panel.

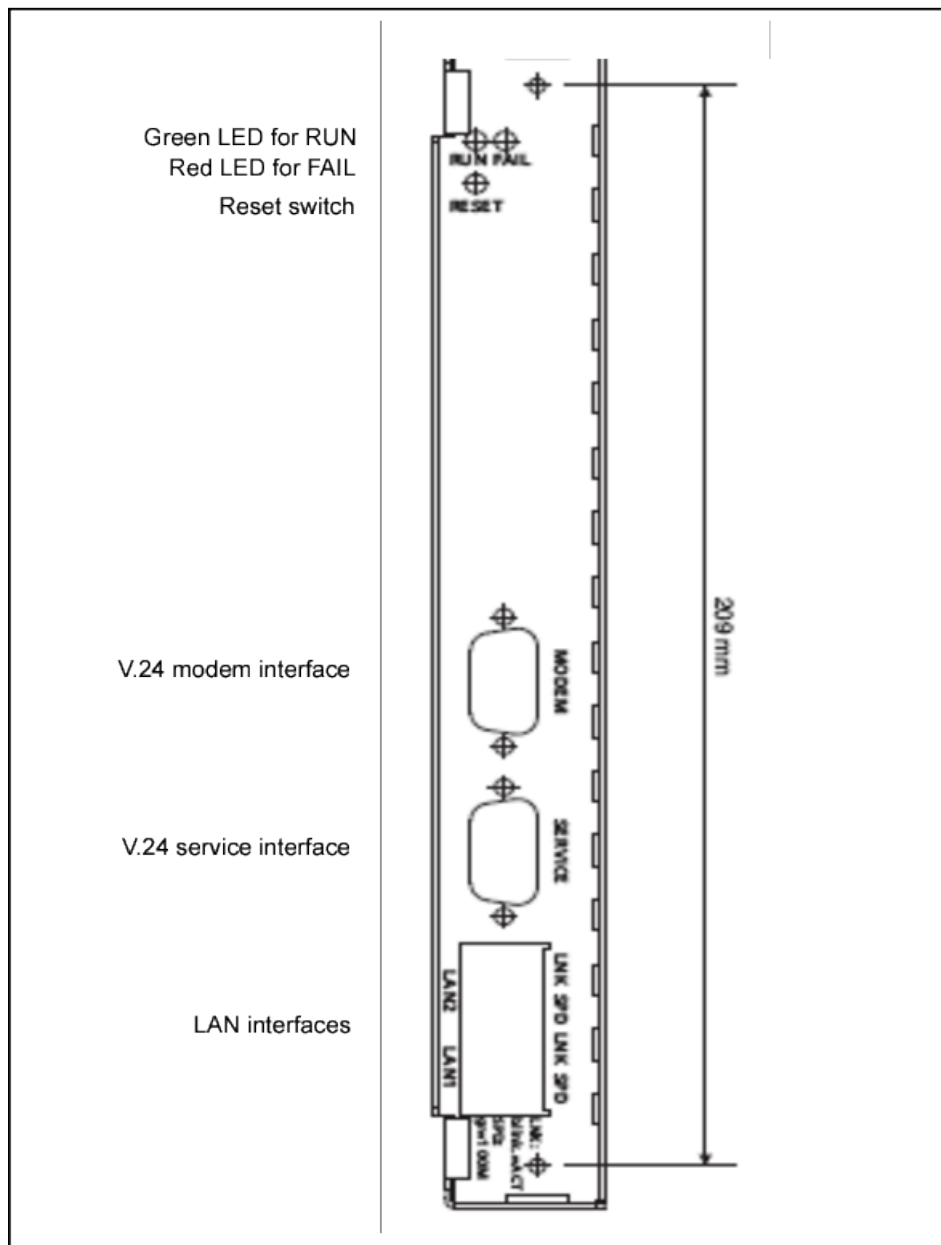

Figure 100: NCUI4 Board Front Panel

9.2.5.4 Power Supply

The NCUI4 board receives a power supply voltage of +5 V over the backplane. The individual voltages required (+3.3 V, +2.5 V, +1.8 V, +1.5 V, and 1.2 V) are generated by the DC-to-DC converter on the board.

9.2.6 PBXXX - Peripheral Board XXX

IMPORTANT: The PBXXX board (Q6401-X) replaces the CDG board (Q2218-X).

The PBXXX (Peripheral Board XXX) module can be used in OpenScape 4000 to support different applications like PNE - Private Network Emulator or CDG - CorNet DPNSS Gateway.

The PBXXX Board provides two digital 2Mbit PCM interfaces and five serial ports V24.

Each digital 2Mbit interface carries 32 channels, which channels can be assigned to speech or to signaling channels. One channel (0) is fixed used for framing. The clock speed of both links is 2.048 MHz.

Four serial interfaces are used for connection to modems, while the last serial interface M is used for maintenance.

9.2.6.1 Hardware Partnumber

Hardware Partnumber: S30810-Q6401-X

9.2.6.2 Interfaces

The PBXXX Board has the following physical interfaces:

On the front:

- 7 Segment display to indicate the status of the card.
- Four V24 interfaces routed to the front of the card via DB15 female mini connectors. On the synchronous V24 ports the following signals are provided: 102,103, 104, 105, 106, 107, (108/1, 108/2), 109, 113, 114, 115 (CCITT spec). The four V24 ports are programmed as DTE. The connection is done via a DB15 female mini connector. The maximum allowable cable load is 2500PF. This is nearly 15 meters for shielded cable.
- One V24 interface (M port at the bottom) is available for maintenance and loading of the initial program. This asynchronous V24 maintenance port can be connected to a local PC or to an external modem to do maintenance and or reloading of the ECG software. The following signals are provided on this interface: 102, 103, 104, 105, 106, 107, (108/1, 108/2), 109, 125 (CCITT spec). The connection is done via a DB15 female mini connector. The maximum allowable cable load is 2500PF. This is nearly 15 meters for shielded cable.

On the back:

Two connectors for connecting to the OpenScape 4000 backplane board, providing power supply and the two 2Mbit PCM interfaces (E1/S2).

On the card:

DIP-switch with 8 selections.

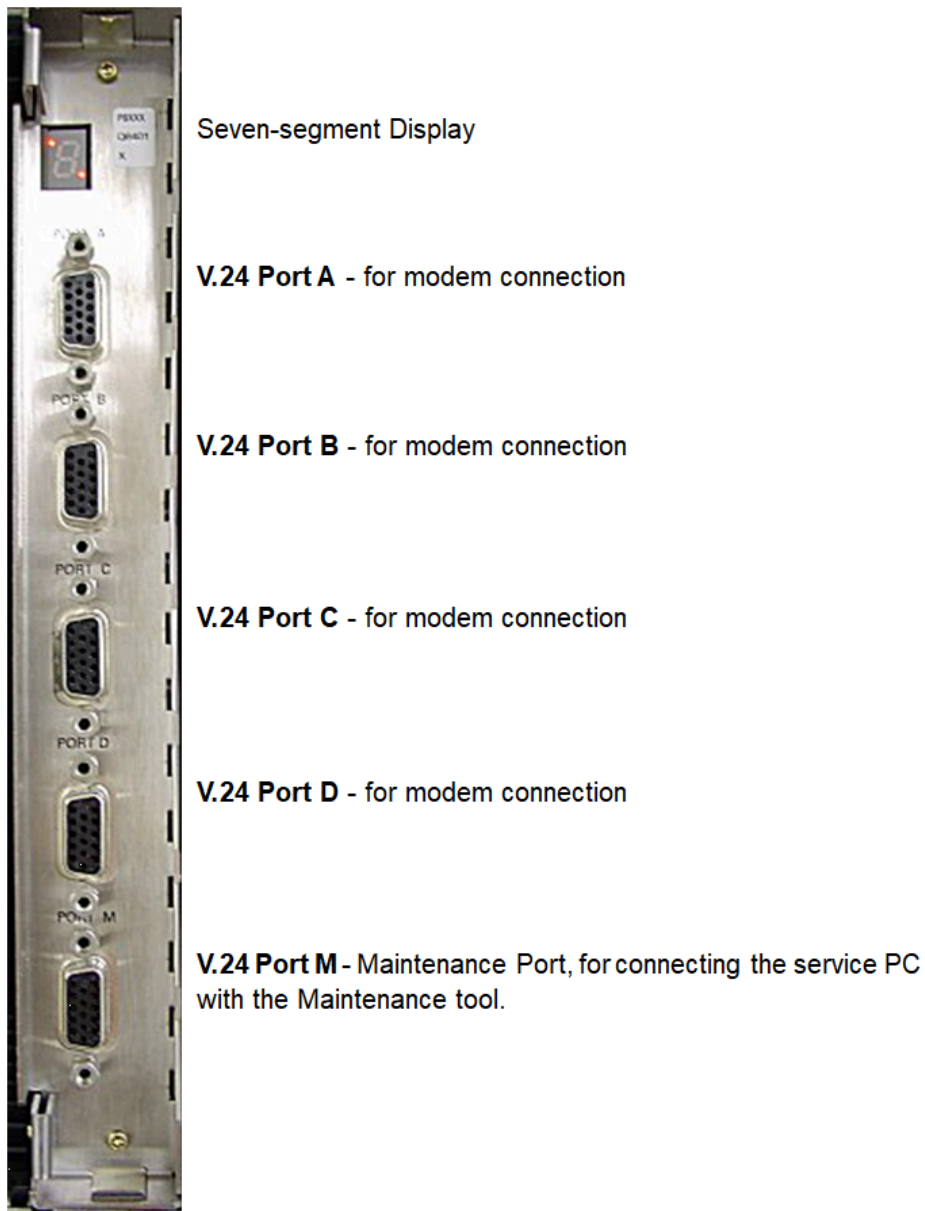

Figure 101: PBXXX - Front Panel

9.2.6.3 Dip-switch

The PBXXX board has a switch for configuration purposes. The figure below shows this component.

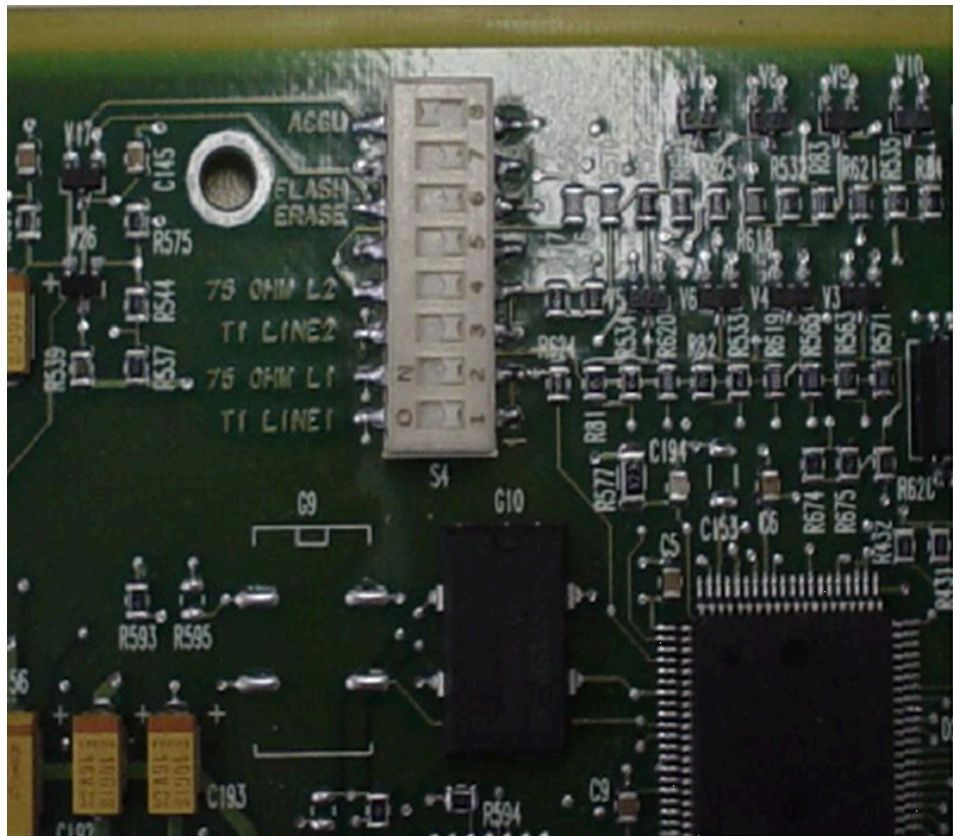

Figure 102: Dip-Switch on PBXXX

The first four switches shall be configured in pairs:

Table 65: Dip switch line 1 configuration

Impedance (ohms)	Switch 1	Switch 2
120	Off	Off
75 default	Off	On
Not used	On	Off
Not used	On	On

Table 66: Dip switch line 2 configuration

Impedance (ohms)	Switch 3	Switch 4
120	Off	Off
75 default	Off	On
Not used	On	Off
Not used	On	On

The next four switches shall be configured alone:

Table 67: Dip switch configuration

Switch	Function
5	Not used
6	Clears flash memory if 'ON' when board is powered up
6	Not connected
7	Always ON. Battery to Real Time Clock

9.2.6.4 Recommendations

- V24 interface grounding: Equipment connected directly to the V24 signaling port (synchronous or maintenance) must be connected to the same earthing point as the PBXXX - OpenScape 4000. If this is not possible a converter for the V24 signaling leads should be used to achieve a galvanic separation between ECG V24 ports and the connected equipment.
- Power Consumption: The PBXXX has a power consumption of 13W.

9.2.6.5 PNE/PBXXX Application

The Private Network Emulator (PNE) is an application that can be loaded on the PBXXX board in order to provide the networking of different OpenScape 4000 systems and systems of other manufacturers via public analog or digital/ISDN networks, supporting full end-end CorNet-N/Cor-Net-NQ functionality (or DPNSS1 for heterogeneous networks). When using the PNE there is no need for expensive leased circuits for tie-line connections between switching systems since the protocol is supported transparently.

With the PNE the private user network can provide the extended features of the company-wide network regardless of the features offered by the network operator. The features offered by network operators are minimal, so that even with the development of virtual private network services (VPN) that are offered by operators only a very few of the supplementary services of a state-of-the-art ISDN private network will be available. For global networking with OpenScape 4000 systems the PNE supports the CorNet functionality independently of the "switched network" of the network operator and regardless whether the lines provided by the operator are analog, digital or ISDN lines.

Interfaces

The PNE over PBXXX has the following physical characteristics:

On the front:

- One 7 segment LED indicating the status of the card
- Four signaling ports for X.25 connections
- One maintenance port (M/A port at the bottom): Asynchronous connection

On the back:

Connector for connecting the OpenScape 4000 backplane board or for connecting the S2 interface module

Physical Connections

In the Installation Instructions OpenScape 4000 you can find some examples how connect the PBXXX board to the ISDN Mail.

9.2.6.6 CDG/PBXXX Application

The CDG application - CorNet DPNSS Gateway - is used to link the OpenScape 4000 system to private systems and networks through Digital Private Network Signaling System No. 1 (DPNSS1) or public exchanges through Digital Access Signaling System No 2 (DASS2).

In connection with the DIUS2 board and an APPCU adapter plug, it is possible to link to the OpenScape 4000 system as follows:

- iSLX, iSDX, EMS 601 systems through DPNSS1 protocol.
- Public exchanges through DASS2 protocol.
- Other OpenScape 4000 systems with DPNSS1 protocol if certified.

Interfaces

The CDG over PBXXX has the following physical characteristics:

- Two E1 links (2Mbits PCM)
- One maintenance port (M port at the bottom) for asynchronous connection to the maintenance computer.

Physical Connections

In the Installation Instructions OpenScape 4000 you can find some examples how connect the PBXXX board to the ISDN Mail.

9.2.7 Ring Generator

The ring generator (RGMOD) can supply different ring currents depending on the country setting and a 150 Volt direct current (Vdc) message-waiting voltage to analog telephones attached to line interfaces in LTUW, L80X and AP3700 shelves.

For lightning protection see [Section 2.3, "Lightning Protection"](#).

IMPORTANT: The RGMOD module is connected to the back of the shelf backplane (X214 10-pin plug). To comply with different country specifications and different voltage and frequency values at the ringer output, these settings are made by means of jumpers on the component side of the board. Ring generator boards reside in LTU shelves but are functionally part of the service unit. The ring generator board can provide ring voltage to other LTU shelves through power wires connecting the LTU

shelf backplanes. Under no circumstances, however, can an LTU shelf receive ring voltage from two ring generator boards.

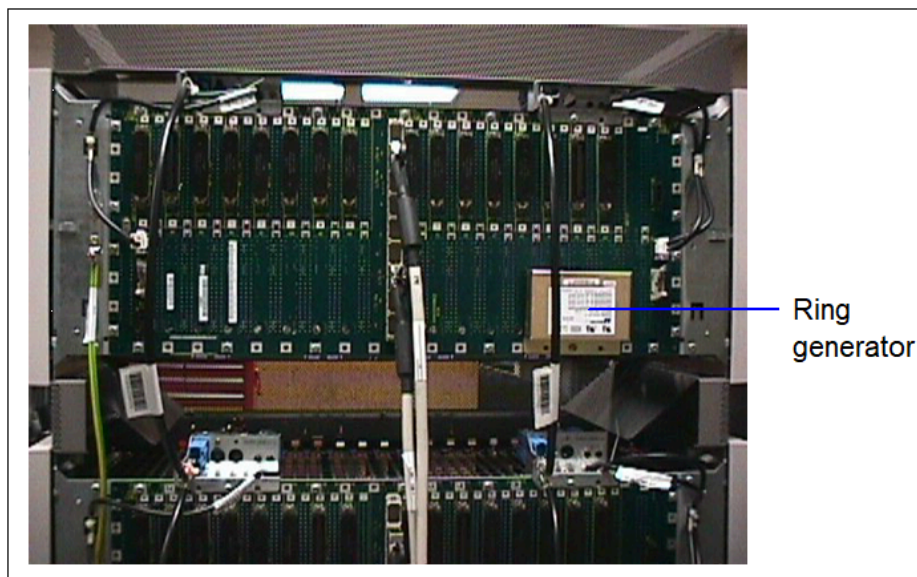

Figure 103: Ring Generator

9.2.7.1 LED Indications

The ring generator does not have any LED indications.

9.2.7.2 Ringer Module Types

- S30807-Q6141-X
- S30122-K5929-X

9.2.7.3 Ringer Settings

Table 68: Ringer Settings

Output	Frequency	Reguliert.	Begrenzter Strom	Rest-welligkeit	Norm
75Vrms	25Hz	5%	67mA	200mV	europ.Standard
65Vrms	25Hz	5%	77mA	200mV	Schweiz
75Vrms	50Hz	5%	67mA	200mV	Frankreich
85Vrms	20Hz	5%	59mA	200mV	USA

Table 69: Ringer Settings

9.2.7.4 Jumper settings for Ring Voltages

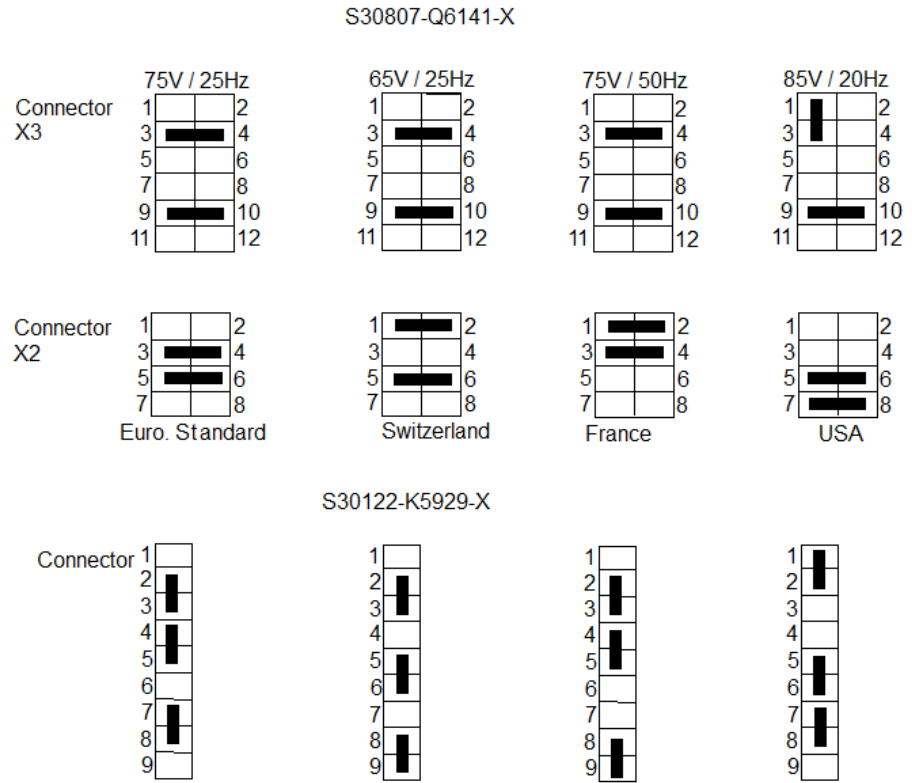

Figure 104: Jumper settings for Ring Voltages

9.2.7.5 Jumper Setting for AC Generator (only for S30810-Q6141-X)

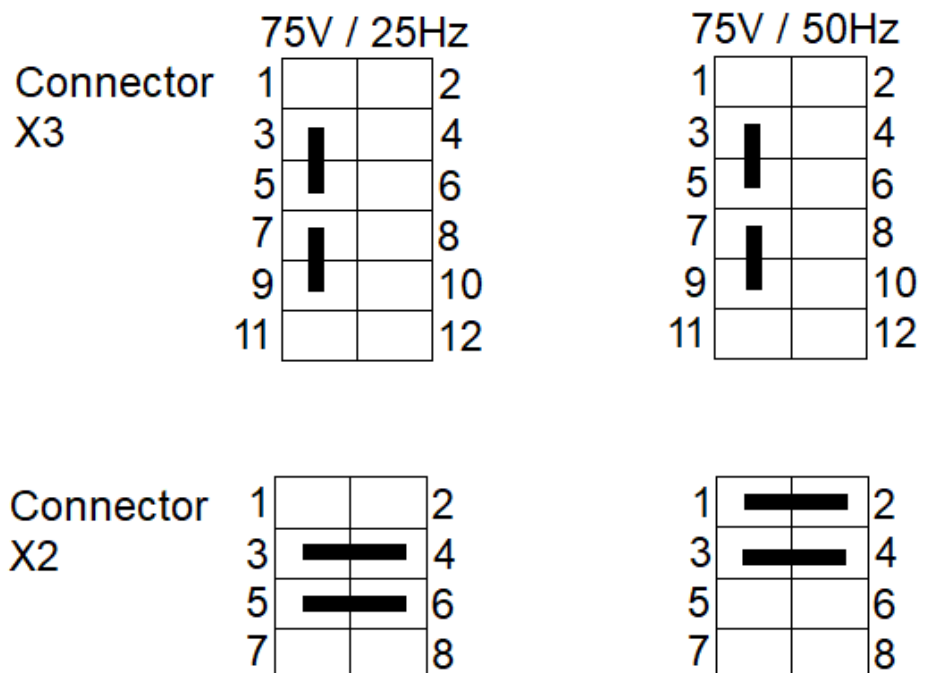

Figure 105: Jumper Setting for AC Generator (only for S30810-Q6141-X)

9.2.7.6 Removing the Ring Generator



CAUTION: The RG module must be switched off before it is inserted or removed. The ring generator board has voltage levels ranging from +75 Volts (V) to -170 V during normal operation. Observe high-voltage electrical safety practices when working with or near this board.

IMPORTANT: If the ring generator is removed, analog telephones served by the ring generator does not ring for incoming calls.

NOTICE: Static Sensitive Devices! Observe all precautions for electrostatic discharge.

To remove the ring generator:

- 1) Ensure the shelf is powered off.
- 2) Remove the screw that attaches the ring generator to the backplane.
- 3) Unplug the ring generator from the 10-pin connector on the backplane.

9.2.7.7 Replacing the Ring Generator

To replace the ring generator:

- 1) Ensure the shelf is powered off.
- 2) Plug the ring generator to the 10-pin connector on the backplane.
- 3) Replace the screw to attach the ring generator to the backplane.

9.2.7.8 Verifying the Ring Generator

There is no easy way to verify the ring generator. If ringing is not present on a shelf, the system receives an LTUCX alarm for loss of ring-sync.

The USERG (Q2468-X) is an option on systems which have large amounts of message waiting and analog telephones. The USERG is installed in slot 19 of an LTU shelf.

9.2.8 SIU/SIUX2

The hardware description for SIU and SIUX2 is the same as SIUX3. Please check [Section 6.3, "SIUX3"](#) for further information.

9.2.9 SLC24 Subscriber Line CMI24

The "Subscriber Line Module CMI24" (SLC24) is an extension board for OpenScape 4000.

The SLC24 board used to connect up CMI base stations and to administer cordless subscribers. Existing SLC16 boards can be replaced with the SLC24 (in Hicom 150 H this is the SLC16n):

Table 70: Assignment of Old and New Boards

Old board		New board		UP0/E port	ADPCM channels *)
Name	Part Number	Name	Part number		
SLC16	S30810-Q2922-*	SLC16n	S30810-Q2193-X100	16	32
SLC16	S30810-Q2151-*	SLC24	S30810-Q2193-X200	24	48

ADPCM = Adaptive Difference Pulse Code Modulation

A maximum of 24 UP0/E ports are available for connecting up base stations or telephones.

The X200 version (Hicom 300) has a 10-pin plug contact strip with a serial port with TLL levels for connecting the existing GPS board SLCSM (Subscriber Line CMI Synchronisation Module; S30807-Q6194-*). A second plug contact strip with a I2C bus, reset track and additional voltages is also provided for an

SLCSS (Subscriber Line CMI Synchronisation Small; S30807-Q6714-*) that is yet to be developed. This can replace the SLCSM.

In contrast to the SLC16, SLC24 now provides an option for switching from 4 PCM highways (A trunk group) to a wideband connection (F trunk group) integrated on the backplane in V3.0 and higher with an additional 4 PCM highways. The system software assigns the highways. Only one trunk group at a time can be used for a single board. The use of wideband (2 x 4 PCM highways) means that a shelf can be used more efficiently when the traffic load on the SLC boards is high.

9.2.9.1 LED Indications

A "ready" (green) and a "fail" (red) LED have been integrated on the SLC24 for status control.

9.2.9.2 X200 Board Layout

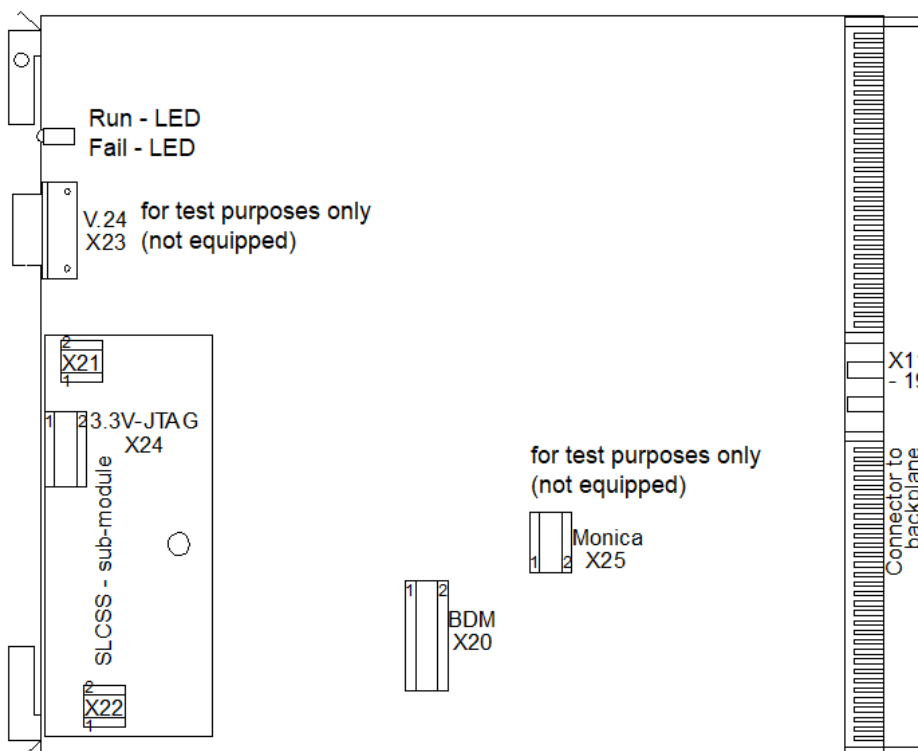

Figure 106: X200 Board Layout

9.2.9.3 Interfaces

- SLCSM Interface X21
A serial interface with TTL levels is implemented on the SLC24. The SLC24 also has a 10-pin plug contact strip (X21) for connecting the SLCSM S30807-Q6194 board directly. A second 10-pin plug contact strip (X22)

has also been fitted, which makes it possible to connect up a new SLCSS directly (not yet developed) as a sub-module.

Table 71: SLCSM Interface X21 Pin Assignments

X21	Signal	I/O	Description	X21	Signal	I/O	Description
Pin 1	N.C.		not connected	Pin 2	RXDA	I	receive data Ch A
Pin 3	TXDA	O	receive data Ch A	Pin 4	N.C.		not connected
Pin 5	0V		Ground	Pin 6	N.C.		not connected
Pin 7	RTSA	O	request to send Ch A	Pin 8	CTSA	I	request to send Ch A
Pin 9	+5V		+5V clock supply	Pin 10	N.C.		not connected

- SLCSS interface X22 (sub-module)

Table 72: SLCSS interface X22 (sub-module) Pin Assignments

X22	Signal	I/O	Description	X22	Signal	I/O	Description
Pin 1	SCL	I/O	I2C bus clock	Pin 2	SDA	I/O	I2C bus data
Pin 3	HRES	O	Reset	Pin 4	P0	I/O	I/O port PP15 at ColdFire
Pin 5	+3.3V		+3.3V clock supply	Pin 6	+3.3V		+3.3V clock supply
Pin 7	CDLSSYN	I/O	2.4 s multiframe cycle	Pin 8	+5V		+5V clock supply
Pin 9	0V		Ground	Pin 10	0V		Ground

- Interface to the backplane

The connection is implemented using a five-row SIPAC socket contact strip. The power supply for the SLC24 is provided by means of this contact strip. All interface and signal lines (e.g. PCM bus, clock lines) are run to the SLC24 by means of the interface. In the X100 variant the interface and signal lines are run symmetrically; in the X200 variant they are run asymmetrically.

- UP0/E interface

A total of 24 (16) UP0/E ports are available as digital subscriber line interfaces. The telephones are connected up by means of the backplane.

- PCM interface

Four PCM highway pairs with wideband switch run to the SLC24 by means of the backplane (in the X100 variant this is two highways without wideband). The highways are divided into receive and transmit directions.

- HDLC interfaces (High Level Data Link Control)

The SLC24 is controlled over an HDLC highway. The 'Extended Line Card Interface Controller' (ELIC, PEB20550) is used to operate the interface.

9.2.9.4 Power Supply

The board receives its power supply by means of the backplane.

The SLC24 requires the following voltages:

- +5V (+/-3%), typical power consumption: 850mA
- +3.3V (+/-3%), locally generated from the +5V power supply, typical power consumption: 500mA
- +2.5V (+/-0.2V), locally generated from the +5V power supply, typical power consumption: 100mA
- -48V (+/-5%), typical power consumption depends on the base stations connected up

The +5V and ground connections are arranged on the SLC24 with leading heavy current contacts and normal contacts on the SIPAC contact strip.

9.2.9.5 Block Diagram

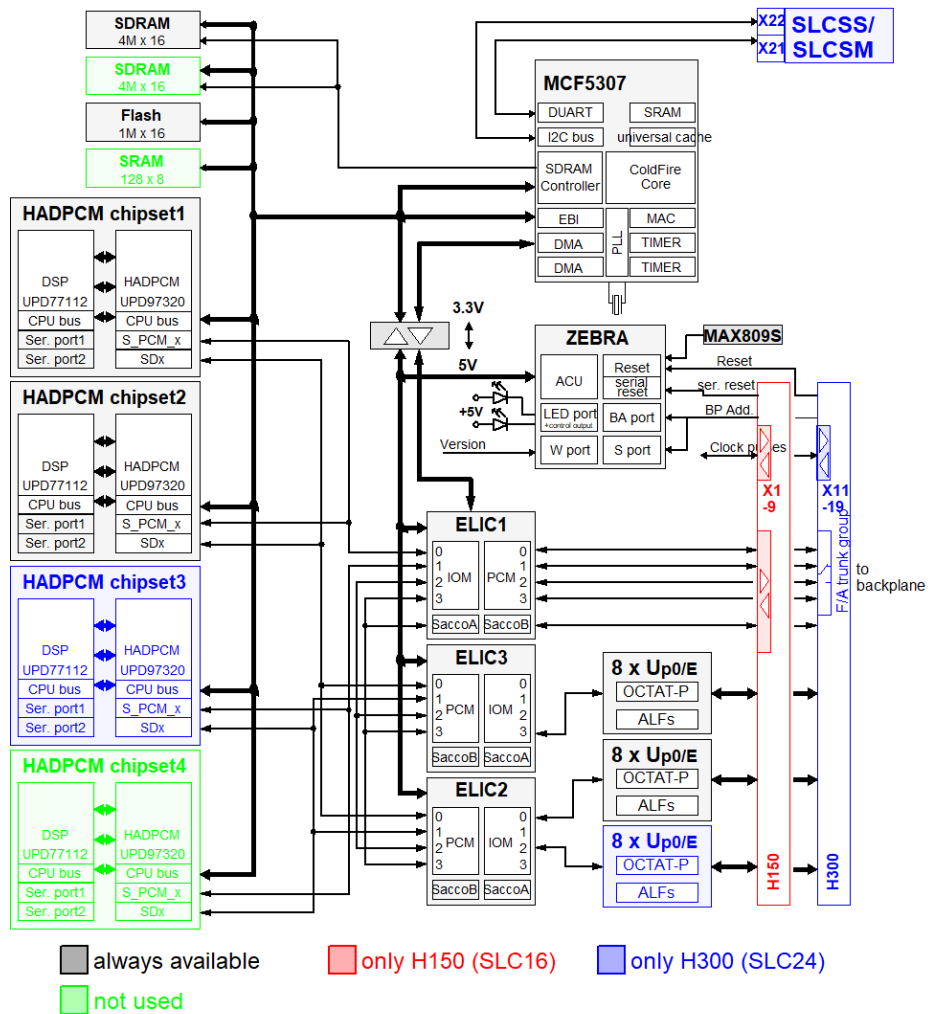

Figure 107: Block Diagram for SLC24

9.2.10 SLMA2

The SLMA2 board provides 24 analog subscriber lines and supports all functions of (on-line) analog telephone sets. The SLMA2 board provides upgraded functionality from the SLMA board. The SLMA2 board is compatible with the SLMA. In addition, with the help of a SIPAC/SIVAPAC adapter, the SLMA2 board can also be used in an LTU shelf without any modifications to existing hardware. However, the system software must be upgraded to V3.5. Any of the 24 lines can be connected to any of the 128 time slots available in the LTUE shelf.



CAUTION: For lightning protection see [Section 2.3, "Lightning Protection"](#).

The board functions are:

- Ringing the line
- Supervising and signaling the line
- Codec function
- Hybrid function 2W to 4W and 4W to 2W
- Test (loopback) capability

9.2.10.1 Module Variant

- SLMA2 Q2246-X

9.2.10.2 LED Indications

The SLMA board front panel contains two LEDs. [Table 60](#) lists the LED indications for the SLMA2 board.

Table 73: SLMA2 Board LED Indications

Red LED	Green LED	Indications
On	Off	The board has initial power applied.
Flashing	Off	The board is being loaded with hardware.
On	Off	The board is defective or out of service.
Off	On	The board is operational and all channels are inactive.
Off	Flashing	The board is operational and one or more channels are active.

9.2.10.3 Interface to the Administration

Shelf address identifier (interface to LTUE/LTUS): The SLMA2 has an interface to LTUE or LTUS; if the card is used in an LTU-shelf, only the first 16 pairs of lines are accessible. The address information is coded within 7 bits. The SLMA2 reads only the first 6 bits (BA0....BA5), in parallel.

[Figure 77](#) shows the system architecture of the SLMA2 board.

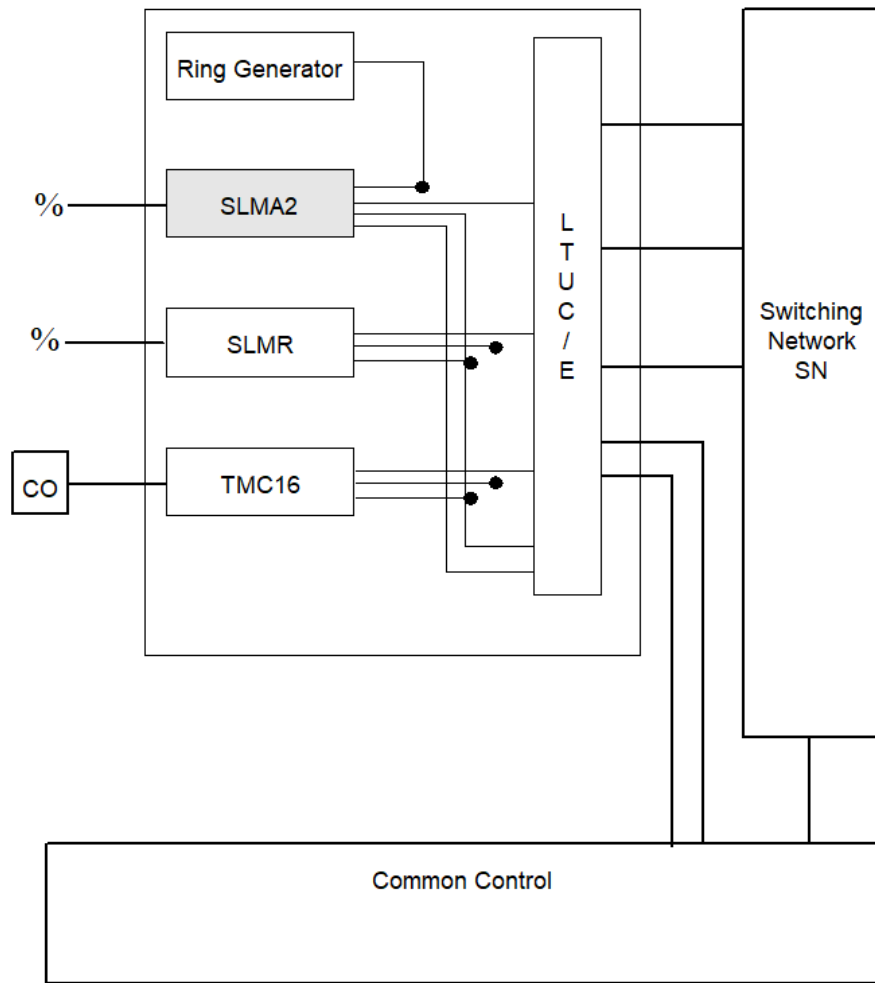

Figure 108: SLMA2 Board, System Architecture

9.2.10.4 Power Supply Interface

The SLMA2 requires the following DC supply voltage from the system:

- +5 V (+/- 5%)
- -48 V (-42 V to -58 V)
- System ground

9.2.10.5 Battery Supply

- Open loop voltage between TIP and RING: less than max. battery voltage
- Current limiting

9.2.10.6 Interfaces

Interface to the Subscriber Line

The interface to the main distribution frame (MDF) consists of 24 pairs of lines. Each pair consists of TIP and RING line.

Interface to the Ring generator

Ringing signal:

The SLMA2 supplies a ringing signal (RING) to alert each subscriber line; this high-voltage signal is generated by an external ring generator. The ringing voltage can be either Ground or Battery referenced. The RING relay (K1) is set by means of the loadware. The ring generator also supplies the SLMA2 with a synchronization signal (RGSYN). The SLMA2 loadware controls the ring cadences per line. The SLMA2 supports two types of ringing. To make sure that the ringing signal produced by the RG is compatible with country-specific requirements, the ringing signal at the common system interface is supervised by a ringing control circuit on board.

Interface to the Switching Network

PCM Highways (interface to LTUCE):

The SLMA2 has access to 128 time slots on four PCM highway in the LTUCE shelf. Each highway has two unidirectional port HI0..HI3 / HO0..HO3. If the board is used in an LTU shelf, only 64 time slots are available and two PCM highways (HI 0/1, Ho 0/1) are connected to the system interface.

Interface to the Central Processor

HDLC-Highway (interface to central processor):

The data exchange between the central processor and the peripheral processor works on the HDLC-Highway. The transfer is a point to multipoint in normal response mode with a rate of 2,048 Mbps. The Highway has two unidirectional ports HDI / HDO.

Interface to the Clock Generator (System clock)

- Master clock For synchronization, the ELIC and the Q-SICOFIs requires a master clock signal CKA which is generated by an external Clock-Generator. Two types of frequency are available. Depending on the signal CLS: CKA = 2,048 MHz (CLS=low) or CKA = 4,098 MHz (CLS=high) The duty cycle is 50%. The SLMA2 works on CKA = 2,048 MHz.
- Synchronization pulse The signal FMB synchronizes the PCM transfer with a clock rate of 250 µsec (e.g. 4 kHz).

Wink off mode

The line is in high impedance state.

Dialing recognition methods

The 2 W - interface supports two types of dialing methods: rotary dialing and DTMF dialing. The timings are configurable and depends on the requirements for different country specifications. In case of DTMF dialing, the SLMA2 line is in voice transmission mode and is connected to the DTMF receiver of an external SIU.

Ring supply

The 2 W - interface provides the line with two types of ringing. The SLMA2 only feed in and controls the ringing signal, which comes from an external ring generator; for different ringing signals, different ring generators are necessary. The timing for ringing is configurable and part of LW data. The RING Signal Supply path reference potential is chosen by the RING-Relay (K1).

The two types of ringing are specified as:

- Battery referenced ringing: typ 85Vrms, 20 Hz
- Ground referenced ringing: typ 85Vrms, 25 Hz or typ 65 Vrms, 25 Hz

The line is fed with 1310 Ω source impedance

The ring voltage is applied to and turned off from each subscriber line near the zero-voltage crossing point by the LW to minimize the impulse noise.

Message waiting indication function (MWI)

Two types of message-waiting methods are supported.

- North American standard:

Message-waiting signal with a DC-voltage of to -150 Vdc between TIP and RING, is switched in to illuminate the neon lamp in the telephone sets.

The ring and message-waiting cadences are controlled by the external ring generators and the LW control.

- COMTEL3 method:

The ringing signal is controlled in such a way, that the 2 W - interface fulfills the specification of message-waiting.

Indication / Signalling

- Supervision/Signalling

Each pair of lines is individually controlled in order to detect switch hook (SHD), ground key (GKD) and fault conditions. The signals are LOW active.

If a line goes off-hook during ringing or message-waiting, the ringing/message-waiting voltage will automatically be disconnected from the line (PD is active).

Threshold of the different types of signalling:

- SHD: 5-10 mA (SHD-output), to indicate the loop-current
- GKD: 10-20 mA (GKD-output), to indicate the current to the ground

Quad-SICOFI

A Quad Signal Processing Codec Filter (QSICOFI) converts voice signal A/D and D/A, controls the gain, matches the impedance, and does the hybrid balancing. A board-specific LW has to be loaded. By means of a 2.048 MHz HDLC highway, the system controller and the SLMA2 can exchange messages. The digitized voice data is sent and received on up to four 2.048 Mbps PCM highways. The time slot switching is done on-board.

The Quad-SICOFI integrates four channels. The data transfer is made by the IOM2 interface.

The function of the the Quad-SICOFI:

- Demultiplexing the signalling information from IOM2-C/I-channel to the SICOFI output pins.

- Multiplexing the indication information from the SICOFI input pins to the IOM2-C/I-channel.
- A/D and D/A conversion.
- Input impedance matching (resistive or complex), additional gain setting and hybrid balancing (on resistive or complex termination impedances) are fully programmable.

9.2.10.7 Connector Pin Assignment

Table 61 lists connector pin assignment of the SLMA2 board.

Table 74: SLMA2 Board Connector Pin Assignment

Signal name	Connector Pin	Signal description	Direction
+5 V	X1-21, X1-40, X2-21, X2-40, X3	power supply +5 Vdc	Input
-48 V	X2-03	power supply -48 Vdc	Input
GND	X1-22, X1-28, X1-33, X1-39, X2-22, X2-23, X2-28, X2-33, X2-39, X3	ground return for the +5 V and -48 V power supply	Input / Output
HO0...HO3	X2-32, X2-31, X2-53, X2-52	PCM Highways	Input
HI0...HI3	X2-32, X2-31, X2-53, X2-52	PCM Highways	Output
HDI	X2-19	HDLC Highways	Output
HDO	X2-13	HDLC Highways	Input
RGSYN	X2-27	Ring synchronization signal	Input
PRS	X2-29	System reset	Input
BA0...BA5	X2-09, X2-30, X2-34, X2-35, X2-18, X2-14	Shelf address identifier	Input
FBPE	X2-46	Flash boot programming enable signal	Input
FMB	X2-37	Clock synchronizing signal	Input
RING	X2-01	Ringin/message-waiting signal	Input
CKA	X2-15	System clock	Input
CLS	X2-16	Clock select	Input

Signal name	Connector Pin	Signal description	Direction
TOUT	X2-45	Shelf-test result output	Output
TRST	X2-47	Boundary scan: Test reset (not used)	Input
TCK	X2-48	Boundary scan: Test clock	Input
TMS	X2-49	Boundary scan: Test mode select	Input
TDI	X2-50	Boundary scan: Test data input	Input
TDO	X2-51	Boundary scan: Test data output	Output

Table 62 lists the tip and ring termination of the SLMA2 board.

Table 75: SLMA2 Board TIP/RING Termination Wires

Signal name	Connector Pin	Signal description
00A	X1-01	channel 0
00B	X1-02	
01A	X1-03	channel 1
01B	X1-04	
02A	X1-05	channel 2
02B	X1-06	
03A	X1-07	channel 3
03B	X1-08	
04A	X1-09	channel 4
04B	X1-10	
05A	X1-11	channel 5
05B	X1-12	
06A	X1-13	channel 6
06B	X1-14	
07A	X1-15	channel 7
07B	X1-16	
08A	X1-17	channel 8

Signal name	Connector Pin	Signal description
08B	X1-18	
09A	X1-19	channel 9
09B	X1-20	
10A	X1-24	channel 10
10B	X1-25	
11A	X1-26	channel 11
11B	X1-27	
12A	X1-29	channel 12
12B	X1-30	
13A	X1-31	channel 13
13B	X1-32	
14A	X1-34	channel 14
14B	X1-35	
15A	X1-37	channel 15
15B	X1-38	
16A	X1-43	channel 16
16B	X1-44	
17A	X1-45	channel 17
17B	X1-46	
18A	X1-47	channel 18
18B	X1-48	
19A	X1-49	channel 19
19B	X1-50	
20A	X1-51	channel 20
20B	X1-52	
21A	X1-53	channel 21
21B	X1-54	
22A	X1-55	channel 22
22B	X1-56	

Signal name	Connector Pin	Signal description
23A	X1-57	channel 23
23B	X1-58	

9.2.10.8 Removing SLM Boards

IMPORTANT: This procedure removes up to 24 analog voice, OPS, and message-waiting channels from service.

NOTICE: Static Sensitive Devices!

Observe all precautions for electrostatic discharge.

To remove SLMA2 board:

1) Deactivate all channels on the board as follows:

- a) Type `DEA-DSSU` and press Enter.
- b) Type the following values, then press Enter.

Field	Value
OFFTYPE	DC
TYPE	PEN
PEN1	<PEN1>
PEN2	<PEN2>

IMPORTANT: PEN1 is the pen of the first channel and PEN2 is the pen of the last channel on the board.

2) Display the status of the board until all channels are free as follows:

- a) Type `DIS-SDSU` and press Enter.
- b) Type the following values, then press Enter.

Field	Value
STATUS	ALL
LINK	<blank>
TYPE	PEN
LEVEL	PER3
LTG	<1 - 32>
LTU	<1 - 8>
SLOT	<1 - 151>
CCT	<0 - 15>

3) When all channels are free, deactivate the board as follows:

- a) Type `DEA-BSSU` and press Enter.
- b) Type the following values, then press Enter.

Field	Value
OFFTYPE	DC
LTG	<1>
LTU	<1 - 8>
SLOT	<1 - 121>
REFOFF	<blank>

- 4) Using the board removal and replacement tool, unseat the board and remove it from the shelf.

9.2.10.9 Replacing SLMA2 Board

To replace SLMA2 board:

- 1) Slide the board into the appropriate slot until you seat it firmly into the backplane connector.
- 2) Activate the SLMA2 board as follows:
 - a) Type ACT-BSSU and press Enter.
 - b) Type the following values, then press Enter.

Field	Value
ONTYPE	AUL
LTG	<1 - 32>
LTU	<1 - 8>
SLOT	<1 - 151>

- 3) Activate the channels on the board as follows:

- a) Type ACT-DSSU and press Enter.
- b) Type the following values, then press enter.

Field	Value
ONTYPE	AUL
TYPE	PEN
PEN1	<PEN1>
PEN2	<PEN2>

IMPORTANT: PEN1 is the pen of the first channel and PEN2 is the pen of the last channel on the board.

9.2.10.10 Verifying the SLMA2 Board

To verify the operation of SLMA2 boards by displaying the status of the board:

- 1) Type DIS-SDSU and press Enter.
- 2) Type the following values, then press Enter.

Field	Value
STATUS	ALL
LINK	<blank>
TYPE	PEN
LEVEL	PER3
LTG	<1 - 32>
LTU	<1 - 8>
SLOT	<1 - 151>
CCT	<0 - 15>

The SLM board is automatically tested on activation.

9.2.11 SLMA3

This section describes the functions and features of the subscriber line module analog (SLMA3) board. It also provides procedures for removing, replacing, and verifying this board.

For lightning protection see [Section 2.3, "Lightning Protection"](#).

9.2.11.1 Functional Description

An SLMA3 board interfaces between the system and analog devices. These boards convert signals from analog-to-digital and from digital-to-analog. They support the following analog devices:

- Announcement recorders
- Dial pulse or DTMF analog single-line telephones
- Fax machines
- Modems
- Music-on-hold equipment
- Paging equipment

The SLMA3 board provides 24 analog channels. This board can receive instructions from the operating system through the LTUCX board. It supports a line loop resistance of 1000 Ohms, which includes the resistance of the terminal equipment. It allows stations to be 2.6 cable kilometers (1.6 cable-miles of #26 American Wire Gauge [AWG] cable) from the system.

The SLMA3 board generates its own ringing voltage and does not require an external ring generator. It supports V.90 (56K) modems with data transmission rates up to 50 kilobits per second (Kbps)

The SLMA3 board has SIPAC shelf connectors.



Figure 109: SLMA3 Board Front Panel

9.2.11.2 LED Indications

Table 63 provides the LED indications for each SLM board. The SLM board front panel contains two LEDs (see Figure 78).

Table 76: SLMA3 Board LED Indications

Red LED	Green LED	Indications
On	Off	The board has initial power applied.
Flashing	Off	The board is being loaded with loadware.
On	Off	The board is defective or out of service.
Off	On	The board is operational and all channels are in the on-hook state.

Red LED	Green LED	Indications
Off	Flashing	The board is operational and one or more channels are in the off-hook state.

9.2.11.3 Country Spread for SLMA3 and SLMA24 Utilization

Table 77: Country spread for Board Utilization Based on the DC Functional Range

Country	Max. loop resistance (Ohm)	Loop current (mA)	Directive	SLMA3	SLMA24
Germany (EU)	600 incl. terminal	18	EC 201 185 §6.1	X	X
	-	20/60	(BAPT 221 ZV MÜ 2a)	X	X
Switzerland	1000 incl. terminal	22	PTT 692.05 No. VD1 A.0.5	X	X
	1000 - 1600 incl. terminal	22 - 15	PTT 692.05 No. VD1 A.0.5		X
Austria (EU)	600 incl. terminal	18	EC 201 185 §6.1	X	X
Belgium (EU)	600 incl. terminal	18	EC 201 185 §6.1	X	X
Netherlands (EU)	600 incl. terminal	18	EC 201 185 §6.1	X	X
	700 incl. terminal	16	T11-50 (edition of 27.11.89)	X	X
Spain (EU)	600 incl. terminal	18	EC 201 185 §6.1	X	X
	900 incl. terminal	20	KD 3 Chapter 3/ §1.1.2	X	X
Great Britain (EU)	600 incl. terminal	18	EC 201 185 §6.1	X	X

Country	Max. loop resistance (Ohm)	Loop current (mA)	Directive	SLMA3	SLMA24
	Loop current characteristic in Figure 19 must be fulfilled.	25 permitted (recommended)	BS6450: Part 4 1993	X	X
Luxembourg (EU)	600 incl. terminal	18	EC 201 185 §6.1	X	X
		20/60	(BAPT 221 ZV MÜ 2a)	X	X
USA OPS interface	800 incl. terminal	16	EIA/ TIA464B-1995 §4.5.2.2 (SLMA3 26mA version for USA)	X	X
USA ONS interface	Loop current characteristic must lie in Region A (+B) in Figure 7	20	EIA/ TIA464B-1995 §4.5.2.1 (SLMA3 26mA version for USA)	X	X
Portugal (EU)	600 incl. terminal	18	EC 201 185 §6.1	X	X
	1800 w/o terminal	15	Derived from pr NP-3247 (1986) §5.5.4.7		X
China	> or = 1000 incl. terminal	18	GB/T 14381-93 §5.7.1.2	X	X
Brazil	600 incl. terminal	18	EC 201 185 §6.1	X	X
Italy (EU)	600 incl. terminal	18	EC 201 185 §6.1	X	X
Poland	optional 1200 (incl. terminal resistance of max. 600)	17.5	PABX-05.1994 §3.3.1	X	X

Country	Max. loop resistance (Ohm)	Loop current (mA)	Directive	SLMA3	SLMA24
Argentina	600 incl. terminal	18	EC 201 185 §6.1	X	X
Singapore	600 incl. terminal	18	EC 201 185 §6.1	X	X
	N.A.	20	IDA TS PSTN1 §6.2.2.1 indirect	X	X
South Africa	100 w/o terminal	20	DPT- SWS-001 2.8.5.1i	X	X
Chile	600 incl. terminal	18	EC 201 185 §6.1	X	X
Denmark (EU)	600 incl. terminal	18	EC 201 185 §6.1	X	X
India	1600 incl. terminal	30	NO. SA 300 MY 90 (May 1990)		X
Greece (EU)	600 incl. terminal	18	EC 201 185 §6.1	X	X
	N.A.	20	TZD/TZV 02-89 §8.4.1.3	X	X
Finland (EU)	600 incl. terminal	18	EC 201 185 §6.1	X	X
	1200/500 incl. terminal (500 > inside a building)	N.A.	TPL 23 (6/87) §6.1 e, f	X	X
France (EU)	600 incl. terminal	18	EC 201 185 §6.1	X	X
	250 incl. terminal	Constant current not permitted	ST/PAA/ TPA/ STP/1063 §2.1.2		X

Country	Max. loop resistance (Ohm)	Loop current (mA)	Directive	SLMA3	SLMA24
Hungary	Specified by manufacturer plus 400 terminal resistance	20	Hungarian Telekom AG spec. used for testing controlled PABX parameters (March 1996)	X	X
Ireland (EU)	600 incl. terminal	18	EC 201 185 §6.1	X	X
	N.A.	22	Derived from TTE 10 (11/97)	X	X
Malaysia	1200 incl. terminal	15	Feature requirements for Malaysia (PN VG I 11/PN Singapore 12.11.1991)		X
Thailand	1800 incl. terminal	20	Feature requirements for Thailand (PN VG I 11/PN Thailand 09.11.1991)		X
Sweden (EU)	600 incl. terminal	18	EC 201 185 §6.1	X	X
	1600 incl. terminal	20	SS 63 63 26 §4 (12/91) for informative only		X
Mexico	1600 incl. terminal with max. 370	N.A.	Derived from NOM-EM-151-SCT1-1998 §5.1.12.1		X

Country	Max. loop resistance (Ohm)	Loop current (mA)	Directive	SLMA3	SLMA24
Czech Republic	1600 w/o terminal	15	Requirements table for HICOM 150 E Modular (24.5.1996)		X
Philippines	1900 incl. terminal	19	EWSD project folder PHI version 4.2/4.6W (6/90)		X
Australia	Inside a building: 600 incl. terminal (recommended value: 1200) Outside a building: 1800	20	AUSTEL TS003-1994 §5.3.1.2 + 5.3.2.3	X (indoors only)	X (if outdoors necessary)
CIS	1800 incl. terminal	15	PABX HICOM 300 Technical Terms and Conditions for Public Switch Telephone Network (TT&C) version 2.0 1992 Chapter 2.4§1.2		X

IMPORTANT: In accordance with the R&TTE directive, all national directives have been withdrawn, that is, are no longer legally prescribed. They can still be used for orientation purposes. The new international directive for the subscriber line interface is EC 201 185 V1.1.1 (1999-02).

EU Directive EC 201 185 and the national directive (if available) are specified for EU countries. The applicable national directive is specified for non-EU countries. The EU Directive was entered if the national directive was unavailable.

The selection criteria for SLMA3 are: max. loop resistance 1000 ohms incl. terminal (300 ohms) and minimum loop current 22mA

(USA: 26mA) at maximum resistance. Higher loop resistance and loop current values are selection criteria for SLMA24.

9.2.11.4 SLMA24 (SLMA2) Properties/Restrictions Compared to SLMA3

Table 78: SLMA24 (SLMA2) Properties/Restrictions Compared to SLMA3

	SLMA3	SLMA24
Part number	S30810-Q2191-C	S30810- Q2246-X
Implemented in system versions	E V3.0, E V3.1, H V1.0 and OpenScape 4000 systems	E V1.0, E V2.0, E V3.0, E V3.1, H V1.0 and OpenScape 4000 systems
SLMA24 and SLMA can be implemented in mixed mode		
DC functional range	Subscriber line resistance 2 x 500 ohms incl. terminal with 300 ohms. Max. loop current 26mA.	Subscriber line resistance 2 x 750 ohms incl. terminal with 300 ohms. Max. loop current < 41mA Iloop at max. loop resistance: 20mA.

	SLMA3	SLMA24
Ring current	<p>Ring current generator is integrated on the board.</p> <p>Setting by AMO ZAND.</p> <p>25Hz/45Vrms :</p> <p>(DEU, AUT, CHE, BEL, LUX, ESP, PRT, GBR, NLD, BRA, ITA, POL, ARG, CHL, SGP, ZAF, CHN, GRC, FIN, CZE, DNK, HUN, IRL, SWE, MEX, THA, MYS).</p> <p>50Hz/45Vrms :FRA</p> <p>20Hz/45Vrms :USA</p> <p>Performance:</p> <p>35 REN (Ringer Equivalence Number) for the entire board.</p> <p>Max. 3 REN (DEU/IM), 2 REN (USA) per port.</p> <p>Typical values for REN:</p> <p>Telephone with electromechanical ringer: 1 REN.</p> <p>Telephone with electronic ringer: 0.1 - 0.4 REN.</p> <p>Symmetrical ring current (a/b)</p>	<p>An additional ring current generator is necessary.</p> <p>RGE: Performance 10 VA, 65 V or 75 V with 25 Hz/50 Hz.</p> <p>RG module: Performance 5 VA or 10 VA, 65 V or 75 V with 25 Hz, 75 V/50 Hz or 85 V/20 Hz.</p> <p>25 Hz: (DEU, AUT, CHE, BEL, LUX, ESP, PRT, GBR, NLD, BRA, ITA, POL, ARG, CHL, SGP, ZAF, CHN, GRC, FIN, CZE, DNK, HUN, IRL, SWE, MEX, THA, MYS).</p> <p>50 Hz: FRA</p> <p>20 Hz: USA</p> <p>Reference value for RGE/ RG module dimensioning:</p> <p>At 10 VA, approx. 320 analog stations can be operated with a traffic value of 0.15 erl. (without group/parallel ringing). However, only max. 1 RGE/RG module is permitted per shelf.</p> <p>Ring current asymmetrical, grounded.</p>
Message Waiting Indication (MWI)	<p>Comtel-3</p> <p>MWI with glow lamps not supported.</p>	

9.2.11.5 Removing the SLMA3 Board

IMPORTANT: This procedure removes up to 24 analog voice channels from service.

NOTICE: Static Sensitive Devices! Observe all precautions for electrostatic discharge.

Remove SLMA3 board as follows:

1) Deactivate all channels on the board as follows:

a) Type `DEA-DSSU` and press Enter.

b) Type the following values, then press Enter.

Field	Value
OFFTYPE	DC
TYPE	PEN
PEN1	<PEN1>
PEN2	<PEN2>

IMPORTANT: PEN1 is the pen of the first channel and PEN2 is the pen of the last channel on the board.

2) Display the status of the board until all channels are free as follows:

a) Type `DIS-SDSU` and press Enter.

b) Type the following values, then press Enter.

Field	Value
STATUS	ALL
LINK	<blank>
TYPE	PEN
LEVEL	PER3
LTG	<1 - 32>
LTU	<1 - 8>
SLOT	<1 - 151>
CCT	<0 - 15>

3) When all channels are available, deactivate the board as follows:

a) Type `DEA-BSSU` and press Enter.

b) Type the following values, then press Enter.

Field	Value
OFFTYPE	DC
LTG	<1>
LTU	<1 - 8>
SLOT	<1 - 121>
REFOFF	<blank>

4) Using the board extractor, unseat the board and remove it from the shelf.

9.2.11.6 Replacing SLMA3 Board

Replace the SLMA3 board as follows:

1) Slide the board into the appropriate slot until you seat it firmly into the backplane connector.

2) Activate the SLMA3 board as follows:

a) Type `ACT-BSSU` and press Enter.

b) Type the following values, then press Enter.

Field	Value
ONTYPE	AUL
LTG	<1 - 32>
LTU	<1 - 8>
SLOT	<1 - 151>

3) Activate the channels on the board as follows:

- a) Type ACT-DSSU and press Enter.
- b) Type the following values, then press Enter.

Field	Value
ONTYPE	AUL
TYPE	PEN
PEN1	<PEN1>
PEN2	<PEN2>

IMPORTANT: PEN1 is the pen of the first channel and PEN2 is the pen of the last channel on the board.

9.2.11.7 Verifying the SLMA3 Board

Verify the operation of the SLMA3 board by displaying the status of the board as follows:

- 1) Type DIS-SDSU and press Enter.
- 2) Type the following values, then press Enter.

Field	Value
STATUS	ALL
LINK	<blank>
TYPE	PEN
LEVEL	PER3
LTG	<1 - 32>
LTU	<1 - 8>
SLOT	<1 - 151>
CCT	<0 - 15>

The SLMA3 board is automatically tested on activation.

9.2.11.8 MDF Assignments

Table 66 shows the SLMA3 board punch-down sequence at the MDF. Cable punch-down is standard. Each channel uses one tip and ring pair. Label the block from channel 00 through 15 or 23, as appropriate.

Table 79: Standard Punch-Down Sequence

Pair No.	Wire Color	Channel No.	Pair No.	Wire Color	Channel No.
1	WHT-BLU BLU-WHT	00	14	BLK-BRN BRN-BLK	13
2	WHT-ORG ORG-WHT	01	15	BLK-SLT SLT-BLK	14
3	WHT-GRN GRN-WHT	02	16	YEL-BLU BLU-YEL	15
4	WHT-BRN BRN-WHT	03	17	YEL-ORG ORG-YEL	16

Pair No.	Wire Color	Channel No.	Pair No.	Wire Color	Channel No.
5	WHT-SLT SLT-WHT	04	18	YEL-GRN GRN-YEL	17
6	RED-BLU BLU-RED	05	19	YEL-BRN BRN-YEL	18
7	RED-ORG ORG-RED	06	20	YEL-SLT SLT-YEL	19
8	RED-GRN GRN-RED	07	21	VIO-BLU BLU-VIO	20
9	RED-BRN BRN-RED	08	22	VIO-ORG ORG-VIO	21
10	RED-SLT SLT-RED	09	23	VIO-GRN GRN-VIO	22
11	BLK-BLU BLU-BLK	10	24	VIO-BRN BRN-VIO	23
12	BLK-ORG ORG-BLK	11	25	VIO-SLT SLT-VIO	Not used.
13	BLK-GRN GRN-BLK	12			

9.2.12 SLMAC

This section describes the functions and features of the subscriber line module analog Clip (SLMAC) board. It also provides procedures for removing, replacing, and verifying this board.



CAUTION: For lightning protection see [Section 2.3, "Lightning Protection"](#).

9.2.12.1 Functional Description

An SLMAC board interfaces between the system and analog devices. These boards convert signals from analog-to-digital and from digital-to-analog. They support the following analog devices:

- Announcement recorders
- Dial pulse or DTMF analog single-line telephones
- Fax machines
- Modems
- Music-on-hold equipment
- Paging equipment

The SLMAC board provides 24 analog channels. This board can receive instructions from the operating system through the LTUCR board. It supports a line loop resistance of 1500Ω, which includes the resistance of the terminal equipment with 600Ω. The board supports a distance of 3.21 Km, considering a line with an impedance of 280Ω/Km (other line impedances see on the table below).

		Max. length #AWG24 / 84,19Ω / km		Max. length #AWG26 / 133,85Ω / km		Max. length "giga"/ 280Ω / km	
	Phone/Device:						
Board	loop resistance (telephone included)	300 Ω	600 Ω	300 Ω	600 Ω	300 Ω	600 Ω
SLMAC	1500 Ω	14,25 km	10,69 km	8,96 km	6,72 km	4,29 km	3,21 km

Table 80: Line impedances

The SLMAC board generates its own ringing voltage and does not require an external ring generator. It supports V.90 (56K) modems with data transmission rates up to 50 kilobits per second (Kbps)

The SLMAC board has SIPAC shelf connectors. Other characteristics:

Table 81: Other SLMAC characteristics

	SLMAC
1500 Ω loop resistance (telephone included)	√
32 mA current loop	√
Adjustable current	√
3 ROW REN / 2 US REN ring load @ 0Ohm length	√
1 REN ring load @ 1500 Ohm length	√
10 REN ring load per board	√
DMTF detection* (on chip)	√
Caller ID FSK ETSI Types 1 & 2	√
Caller ID DTMF: ETSI Types 1 & 2, DNK, BRA, Bellcore MDMF & SDMF	√
MWI FSK ETSI, Bellcore MDMF & SDMF	√
MWI Comtel3	√
Modem tone detection	√
Modem V.90 data transmission	√
Calculable impedance for each country	√

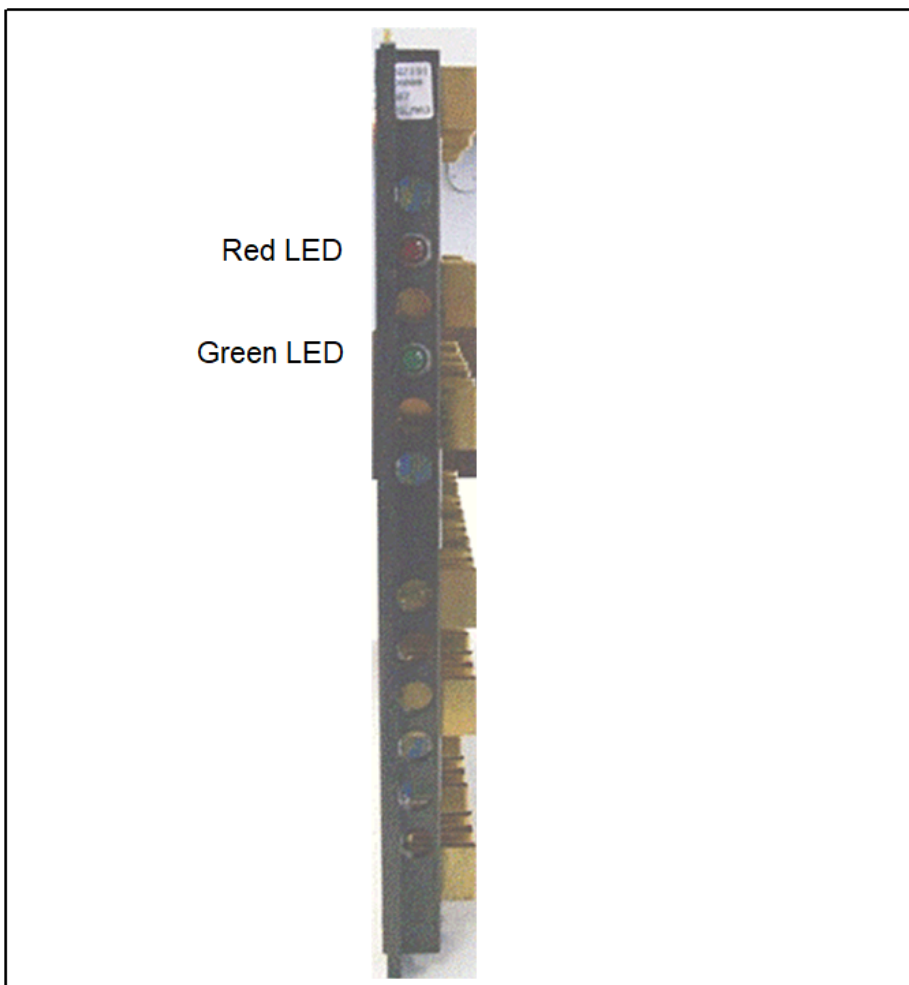

Figure 110: SLMAC Board Front Panel

Properties/Restrictions SLMAC

Table 82: Properties and Restrictions for the SLMAC Board

Properties/Restrictions	SLMAC
Part number	S30810-Q2191-C
Implemented in system versions	E V3.0, E V3.1, H V1.0 and OpenScape 4000 systems
DC functional range	Subscriber line resistance 2 x 750 ohms incl. terminal with 300 ohms. Max. loop current 32mA.

Properties/Restrictions	SLMAC
Ring current	<p>Ring current generator is integrated on the board.</p> <p>Setting by AMO ZAND.</p> <p>The ring current depends on the load and has a maximum value of 45Vrms.</p> <p>Performance:</p> <p>35 REN (Ringer Equivalence Number) for the entire board.</p> <p>Max. 3 REN (GER/MAL)</p> <p>Typical values for REN:</p> <p>Telephone with electromechanical ringer: 1 REN.</p> <p>Telephone with electronic ringer: 0.1 - 0.4 REN.</p> <p>Symmetrical ring current (a/b)</p> <p>Devices which require groundstart ringers are not supported.</p> <p>OPS interfaces in U.S. are not supported.</p>
Caller ID	Released for all countries excepting for Japan
Message Waiting Indication (MWI)	Comtel-3 MWI with glow lamps not supported.

9.2.12.2 LED Indications

Table 70 provides the LED indications for each SLMA boards. The SLMAC board front panel contains two LEDs (red and green).

Table 83: SLMAC Board LED Indications

Red LED	Green LED	Indications
On	Off	The board has initial power applied.
Flashing	Off	The board is being loaded with loadware.
On	Off	The board is defective or out of service.
Off	On	The board is operational and all channels are in the on-hook state.
Off	Flashing	The board is operational and one or more channels are in the off-hook state.

9.2.12.3 Removing the SLMAC Board

IMPORTANT: This procedure removes up to 24 analog voice channels from service.

NOTICE: Static Sensitive Devices! Observe all precautions for electrostatic discharge.

Remove SLMAC board as follows:

1) Deactivate all channels on the board as follows:

a) Type `DEA-DSSU` and press Enter.

b) Type the following values, then press Enter.

Field	Value
OFFTYPE	DC
TYPE	PEN
PEN1	<PEN1>
PEN2	<PEN2>

IMPORTANT: PEN1 is the pen of the first channel and PEN2 is the pen of the last channel on the board.

2) Display the status of the board until all channels are free as follows:

a) Type `DIS-SDSU` and press Enter.

b) Type the following values, then press Enter.

Field	Value
STATUS	ALL
LINK	<blank>
TYPE	PEN
LEVEL	PER3
LTG	<1 - 32>
LTU	<1 - 8>
SLOT	<1 - 151>
CCT	<0 - 15>

3) When all channels are available, deactivate the board as follows:

a) Type `DEA-BSSU` and press Enter.

b) Type the following values, then press Enter.

Field	Value
OFFTYPE	DC
LTG	<1>
LTU	<1 - 8>
SLOT	<1 - 121>
REFOFF	<blank>

4) Using the board extractor, unseat the board and remove it from the shelf.

9.2.12.4 Replacing SLMAC Board

Replace the SLMAC board as follows:

1) Slide the board into the appropriate slot until you seat it firmly into the backplane connector.

2) Activate the SLMAC board as follows:

- a) Type ACT-BSSU and press Enter.
- b) Type the following values, then press Enter.

```
Field      Value
ONTYPE    AUL
LTG       <1 - 32>
LTU       <1 - 8>
SLOT      <1 - 151>
```

3) Activate the channels on the board as follows:

- a) Type ACT-DSSU and press Enter.
- b) Type the following values, then press Enter.

```
Field      Value
ONTYPE    AUL
TYPE      PEN
PEN1      <PEN1>
PEN2      <PEN2>
```

IMPORTANT: PEN1 is the pen of the first channel and PEN2 is the pen of the last channel on the board.

9.2.12.5 Verifying the SLMAC Board

Verify the operation of the SLMAC board by displaying the status of the board as follows:

- 1) Type DIS-SDSU and press Enter.
- 2) Type the following values, then press Enter.

```
Field      Value
STATUS     ALL
LINK       <blank>
TYPE       PEN
LEVEL      PER3
LTG       <1 - 32>
LTU       <1 - 8>
SLOT      <1 - 151>
CCT       <0 - 15>
```

The SLMAC board is automatically tested on activation.

9.2.12.6 MDF Assignments

Table 84: Standard Punch-Down Sequence

Pair No.	Wire Color	Channel No.	Pair No.	Wire Color	Channel No.
1	WHT-BLU BLU-WHT	00	14	BLK-BRN BRN-BLK	13
2	WHT-ORG ORG-WHT	01	15	BLK-SLT SLT-BLK	14

Pair No.	Wire Color	Channel No.	Pair No.	Wire Color	Channel No.
3	WHT-GRN GRN-WHT	02	16	YEL-BLU BLU-YEL	15
4	WHT-BRN BRN-WHT	03	17	YEL-ORG ORG-YEL	16
5	WHT-SLT SLT-WHT	04	18	YEL-GRN GRN-YEL	17
6	RED-BLU BLU-RED	05	19	YEL-BRN BRN-YEL	18
7	RED-ORG ORG-RED	06	20	YEL-SLT SLT-YEL	19
8	RED-GRN GRN-RED	07	21	VIO-BLU BLU-VIO	20
9	RED-BRN BRN-RED	08	22	VIO-ORG ORG-VIO	21
10	RED-SLT SLT-RED	09	23	VIO-GRN GRN-VIO	22
11	BLK-BLU BLU-BLK	10	24	VIO-BRN BRN-VIO	23
12	BLK-ORG ORG-BLK	11	25	VIO-SLT SLT-VIO	Not used.
13	BLK-GRN GRN-BLK	12			

[Table 71](#) shows the SLMAC board punch-down sequence at the MDF. Cable punch-down is standard. Each channel uses one tip and ring pair. Label the block from channel 00 through 15 or 23, as appropriate.

9.2.13 SLMAE

The SLMAE (**S**ubscriber **L**ine **M**odule **A**nalog **E**nhanced) board is an analog T/R interface. It replaces the SLMAC (S30810-Q2191-C), SLMA (S30810-Q2041-X/S30810-Q 2157-X) and SLMA2 (S30810-Q2246-X) boards:



CAUTION: For lightning protection see [Section 2.3, "Lightning Protection"](#).

9.2.13.1 Functional description

- SLMAE (S30810-Q2225-X) = 24 analog T/R interfaces

The features are the same with one exception:

- The connection of external extensions via OPS (Off-Premises Station) signaling is no longer supported on SLMA2 (for U.S. only) but on SLMAR.

The SLMAE board supports calling name identification presentation (CLIP). This board generates its own ring voltages (71 Veff) and does not require an external ring voltage generator. Other characteristics:

Table 85: Other SLMAE characteristics

	SLMAE
1800 Ω loop resistance (telephone included)	√
32 mA current loop	√
Adjustable current	√
75 Vrms balanced ring	√
3 ROW REN / 2 US REN ring load @ 0Ohm length	√
1 REN ring load @ 1500 Ohm length	√
10 REN ring load per board	√
DMTF detection* (on chip)	√
Caller ID FSK ETSI Types 1 & 2	√
Caller ID DTMF: ETSI Types 1 & 2, DNK, BRA, Bellcore MDMF & SDMF	√
MWI FSK ETSI, Bellcore MDMF & SDMF	√
MWI Comtel3	√
MWI Neon	√
Modem tone detection	√
Modem V.90 data transmission	√
Calculable impedance for each country	√

It supports a line loop resistance of 1800 Ohms - line distance of 4.29km for a standard 600hms telephone, and considering a line with an impedance of 280Ω/Km. Other line impedances, see below:

Table 86: Other line impedances

	Max. length #AWG24 / 84,19Ω / km	Max. length #AWG26 / 133,85Ω / km	Max. length "giga" / 280Ω / km
Phone/Device:			

		Max. length #AWG24 / 84,19Ω / km		Max. length #AWG26 / 133,85Ω / km		Max. len "giga"/ 2
Board	loop resistance (telephone included)	300 Ω	600 Ω	300 Ω	600 Ω	300 Ω
SLMAE	1800 Ω	17,82 km	14,25 km	11,21 km	8,96 km	5,36 km

Touch Guard



WARNING: The board is fitted with a touch guard because the onboard heat sinks are energized. Do not remove this touch guard.

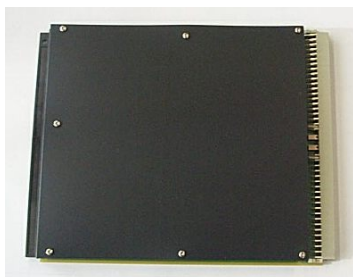

Figure 111: SLMAE with Touch Guard

9.2.13.2 LED Indications

Table 73 provides the LED indications for each SLMA boards. The SLMAE board front panel contains two LEDs (red and green).

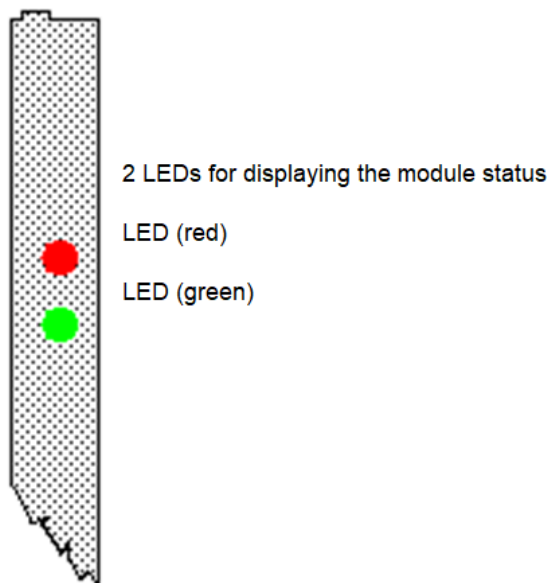

Figure 112: SLMAE - Front Panel

IMPORTANT: To ensure sufficient shielding, provide the board with a shielding panel.

LED Statuses and their meaning

Red LED	Green LED	Status	Action
Off	Off	Board not receiving power or not plugged in correctly. Board is out of order.	Check plug contact on board.
On	Off	Board is receiving power and board test is in progress. Board is defective if status remains unchanged (board test unsuccessful).	Replace board.
		Loadware loading not successfully completed. Board is faulty.	Replace board.
		Error detected on board. Board is deactivated (not applicable to errors detected by test loops) or board was deactivated using OpenScape 4000 Manager.	Check whether the board was deactivated using OpenScape 4000 Manager. If not, replace board.
Flashing	Off	Loadware is being loaded.	
Off	On	Board test completed successfully. Board is OK (idle state).	
Off	Flashing	At least one subscriber line circuit is activated.	

9.2.13.3 Removing SLMAE Board

IMPORTANT: This procedure removes up to 24 analog voice channels from service.

NOTICE: Static Sensitive Devices! Observe all precautions for electrostatic discharge.

Remove SLMAE board as follows:

1) Deactivate all channels on the board as follows:

a) Type `DEA-DSSU` and press Enter.

b) Type the following values, then press Enter.

Field	Value
OFFTYPE	DC
TYPE	PEN
PEN1	<PEN1>
PEN2	<PEN2>

IMPORTANT: PEN1 is the pen of the first channel and PEN2 is the pen of the last channel on the board.

2) Display the status of the board until all channels are free as follows:

a) Type `DIS-SDSU` and press Enter.

b) Type the following values, then press Enter.

Field	Value
STATUS	ALL
LINK	<blank>
TYPE	PEN
LEVEL	PER3
LTG	<1 - 32>
LTU	<1 - 8>
SLOT	<1 - 151>
CCT	<0 - 15>

3) When all channels are available, deactivate the board as follows:

a) Type `DEA-BSSU` and press Enter.

b) Type the following values, then press Enter.

Field	Value
OFFTYPE	DC
LTG	<1>
LTU	<1 - 8>
SLOT	<1 - 121>
REFOFF	<blank>

4) Using the board extractor, unseat the board and remove it from the shelf.

9.2.13.4 Replacing SLMAE Board

Replace the SLMAE board as follows:

1) Slide the board into the appropriate slot until you seat it firmly into the backplane connector.

2) Activate the SLMAE board as follows:

a) Type `ACT-BSSU` and press Enter.

b) Type the following values, then press Enter.

Field	Value
ONTYPE	AUL
LTG	<1 - 32>
LTU	<1 - 8>
SLOT	<1 - 151>

3) Activate the channels on the board as follows:

- a) Type ACT-DSSU and press Enter.
- b) Type the following values, then press Enter.

Field	Value
ONTYPE	AUL
TYPE	PEN
PEN1	<PEN1>
PEN2	<PEN2>

IMPORTANT: PEN1 is the pen of the first channel and PEN2 is the pen of the last channel on the board.

9.2.13.5 Verifying the SLMAE Board

Verify the operation of the SLMAE board by displaying the status of the board as follows:

- 1) Type DIS-SDSU and press Enter.
- 2) Type the following values, then press Enter.

Field	Value
STATUS	ALL
LINK	<blank>
TYPE	PEN
LEVEL	PER3
LTG	<1 - 32>
LTU	<1 - 8>
SLOT	<1 - 151>
CCT	<0 - 15>

The SLMAE board is automatically tested on activation.

9.2.13.6 MDF Assignments

- For connecting to the SIVAPAC connector on the backplane: [Table 74](#)
- For connecting to the connector panels using RJ45 jacks: [Table 75](#)
- For U.S. only: For connecting to the connector panels with a CHAMP jack: [Table 76](#)

Table 87: SLMAE - SIVAPAC Connector Assignment on the Backplane

Pair	a-Wire (Tip)	b-Wire (Ring)	SIVAPAC Connector	SLMAE8, SLMAE		MDFU-E	Notes
1	wht/blu		1	1a	Port 1	1a	
		blu/wht	23	1b		1b	
2	wht/ora		3	2a	Port 2	2a	

Pair	a-Wire (Tip)	b-Wire (Ring)	SIVAPAC Connector	SLMAE8, SLMAE		MDFU-E	Notes
		ora/wht	4	2b		2b	
3	wht/grn		5	3a	Port 3	3a	
		grn/wht	6	3b		3b	
4	wht/brn		7	4a	Port 4	4a	
		brn/wht	8	4b		4b	
5	wht/gry		9	5a	Port 5	5a	
		gry/wht	10	5b		5b	
6	red/blu		11	6a	Port 6	6a	
		blu/red	12	6b		6b	
7	red/ora		13	7a	Port 7	7a	
		ora/red	14	7b		7b	
8	red/grn		15	8a	Port 8	8a	
		grn/red	16	8b		8b	
9	red/brn		17	9a	Port 9	9a	Not used for SLMAE8 (HiPath 3000)
		brn/red	18	9b		9b	
10	red/gry		19	10a	Port 10	10a	
		gry/red	20	10b		10b	
11	blk/blu		24	11a	Port 11	11a	

Pair	a-Wire (Tip)	b-Wire (Ring)	SIVAPAC Connector	SLMAE8, SLMAE		MDFU-E	Notes
		blu/blk	25	11b		11b	
12	blk/ora		26	12a	Port 12	12a	Not used for SLMAE8 (HiPath 3000)
		ora/blk	27	12b		12b	
13	blk/grn		29	13a	Port 13	13a	
		grn/blk	30	13b		13b	
14	blk/brn		31	14a	Port 14	14a	
		brn/blk	32	14b		14b	
15	blk/gry		34	15a	Port 15	15a	
		gry/blk	35	15b		15b	
16	yel/blu		37	16a	Port 16	16a	
		blu/yel	38	16b		16b	
17	yel/ora		43	17a	Port 17	17a	
		ora/yel	44	17b		17b	
18	yel/grn		45	18a	Port 18	18a	
		grn/yel	46	18b		18b	
19	yel/brn		47	19a	Port 19	19a	
		brn/yel	48	19b		19b	
20	yel/gry		49	20a	Port 20	20a	

Pair	a-Wire (Tip)	b-Wire (Ring)	SIVAPAC Connector	SLMAE8, SLMAE		MDFU-E	Notes
		gry/yel	50	20b		20b	
21	vio/blu		51	21a	Port 21	21a	
		blu/vio	52	21b		21b	
22	vio/ora		53	22a	Port 22	22a	
		ora/vio	54	22b		22b	
23	vio/grn		55	23a	Port 23	23a	
		grn/vio	56	23b		23b	
24	vio/brn		57	24a	Port 24	24a	
		brn/vio	58	24b		24b	

Table 88: SLMAE - Connector Panel Assignment with RJ45 Jacks

RJ45 jack		SLMAE8, SLMAE	Notes
No.	Pin		
1	4	1a	
	5	1b	
2	4	2a	
	5	2b	
3	4	3a	
	5	3b	
4	4	4a	
	5	4b	
5	4	5a	
	5	5b	
6	4	6a	

RJ45 jack		SLMAE8, SLMAE	Notes	
No.	Pin			
	5	6b		
7	4	7a		
	5	7b		
8	4	8a		
	5	8b		
9	4	9a	Not used for SLMAE8 (HiPath 3000)	
	5	9b		
10	4	10a		
	5	10b		
11	4	11a		
	5	11b		
12	4	12a		
	5	12b		
13	4	13a		
	5	13b		
14	4	14a		
	5	14b		
15	4	15a		
	5	15b		
16	4	16a		
	5	16b		
17	4	17a		Not used for SLMAE8 (HiPath 3000)
	5	17b		
18	4	18a		
	5	18b		
19	4	19a		
	5	19b		
20	4	20a		

RJ45 jack		SLMAE8, SLMAE	Notes
No.	Pin		
	5	20b	
21	4	21a	
	5	21b	
22	4	22a	
	5	22b	
23	4	23a	
	5	23b	
24	4	24a	
	5	24b	

Table 89: SLMAE - Connector Panel Assignment with a CHAMP Jack (for U.S. only)

CHAMP jack	SLMAE8, SLMAE			Notes
1	1a	1 Ring	Port 1	
26	1b	1 Tip		
2	2a	2 Ring	Port 2	
27	2b	2 Tip		
3	3a	3 Ring	Port 3	
28	3b	3 Tip		
4	4a	4 Ring	Port 4	
29	4b	4 Tip		
5	5a	5 Ring	Port 5	
30	5b	5 Tip		
6	6a	6 Ring	Port 6	
31	6b	6 Tip		
7	7a	7 Ring	Port 7	
32	7b	7 Tip		
8	8a	8 Ring	Port 8	
33	8b	8 Tip		

CHAMP jack	SLMAE8, SLMAE			Notes
9	9a	9 Ring	Port 9	Not used for SLMAE8 (HiPath 3000)
34	9b	9 Tip		
10	10a	10 Ring	Port 10	
35	10b	10 Tip		
11	11a	11 Ring	Port 11	
36	11b	11 Tip		
12	12a	12 Ring	Port 12	
37	12b	12 Tip		
13	13a	13 Ring	Port 13	
38	13b	13 Tip		
14	14a	14 Ring	Port 14	
39	14b	14 Tip		
15	15a	15 Ring	Port 15	
40	15b	15 Tip		
16	16a	16 Ring	Port 16	
41	16b	16 Tip		
17	17a	17 Ring	Port 17	Not used for SLMAE8 (HiPath 3000)
42	17b	17 Tip		
18	18a	18 Ring	Port 18	
43	18b	18 Tip		
19	19a	19 Ring	Port 19	
44	19b	19 Tip		
20	20a	20 Ring	Port 20	
45	20b	20 Tip		
21	21a	21 Ring	Port 21	
46	21b	21 Tip		
22	22a	22 Ring	Port 22	
47	22b	22 Tip		
23	23a	23 Ring	Port 23	

CHAMP jack	SLMAE8, SLMAE			Notes
48	23b	23 Tip		
24	24a	24 Ring	Port 24	
49	24b	24 Tip		

9.2.14 SLMAR

The subscriber line module analog, rural (SLMAR) board (S30810-Q2480-X) provides 8 analog subscriber lines supporting the basic analog line features as well as the three major features (extended loop, pulse metering and line testing) required for the rural marketplace.



CAUTION: For lightning protection see [Section 2.3, "Lightning Protection"](#).

9.2.14.1 Feature Overview

The SLMAR board provides the following functions:

- Ringing (balanced) the line
- Supervising and signalling the line
- Codec function
- Hybrid function (2W to 4W and 4W to 2W)
- Self-tests, report errors under the following conditions:
 - DC-to-DC converter failure.
 - Loop too long if configured for pulse metering with tones (refer to [Payphones](#) and [Short/Long Loops](#)).
 - Loop fault which may cause excessive loop current or unusual signalling events
- Extended loop capability (supports a line loop resistance of 3000Ohms - line distance of 8.5km for a standard 600Ohms telephone.)
- Pulse metering using tones, battery reversal or a combination of both
- Support of Line Test feature
- COMTEL3 supervision
- The SLMAR interfaces to four PCM highways on the backplane, giving access to 128 time slots. Each highway has two uni-directional ports (HI0 - HI3 / HO0 - HO3)
- Communicates with the central processor over the 2.048 Mbps HDLC highway through uni-directional ports HDO and HDI

9.2.14.2 LED Indications

The SLMAR board has a green LED and a red LED. The green LED indicates card status and channel activity; the red LED indicates card status and results of self-test.

Table 77 lists the LED indications of the SLMAR board.

Table 90: SLMAR LED Indications

Red LED	Green LED	Indication
Off	Off	Dead card
On	Off	Initial power on
Flashing	Off	Loading
On	Off	Defective board
Off	On	The board is working but does not have any no activity
Off	Flashing	The board is working and has an active channel.

9.2.14.3 Subscriber Interface

Battery Feed, refer to [Payphones](#) and [Short/Long Loops](#).

The subscriber interface of the SLMAR board is equipped with the following:

- Constant off hook current (talk state): 21mA nominal (18mA minimum).
- Current limiting in any state: 100mA nominal.
- Maximum on hook current: 5mA (refer to [Payphones](#) and [Short/Long Loops](#)).
- On hook voltage: V (wire a) = -61VDC nominal; V (wire b)= -2VDC nominal.
- Off hook voltage (no boosted battery; loop =1200 Ohm): Va= -44VDC nominal; Vb= -19VDC nominal.
- Offhook voltage (boosted battery; loop = 3000 Ohm): Va= -32 VDC nominal; Vb= +32VDC nominal.
- Reverse battery polarity configurable for signalling applications.

Ringling Signal:

The SLMAR board does not use ringling signal or ring synchronization (RGSYNG) from the backplane. The ring signal applied to the subscriber line is generated in the interface circuitry. Ring signal amplitude and frequency is configured by country specific coefficients in loadware. Cadencing is under control of loadware.

The SLMAR supplies balanced ring signal with nominal 22VDC offset.

Hookswitch Detection:

- Off hook threshold: 10mA nominal.
- On hook threshold: 6.5mA nominal.
- Ring trip: 6.5mA nominal.
- Ring signal is automatically removed within two cycles after off hook occurs.

Dialling Recognition:

- Rotary dialing is supported. Timing requirements are configurable based upon country requirements.

- DTMF dialling recognition is accomplished by voice path connection to an external DTMF receiver in a SIU.

Wink Off:

- The line is placed in a high impedance mode.
- No on hook current is supplied during wink off.

Ground Key Detect/Ground Fault Detect:

Ground key detect is not supported on loops requiring boosted battery. These are loops with dc resistance, including the telephone set, exceeding approximately 2150 Ohms (refer to [Payphones](#) and [Short/Long Loops](#)). The difference between ground key detection and ground fault detection is in timing, this is controlled in loadware.

IMPORTANT: Ground key/fault conditions are not guaranteed on all operating conditions and tolerances of hardware. Under absolute worst case hardware and environment conditions the ground current required to assert GKD may exceed the loop current.

- Maximum current to ground to assert GKD = 24mA.
- Minimum current to ground to unassert GKD = 9mA.

Message Waiting:

- Message waiting is supported on the COMTEL3 telephone by means of the ring signal interface.
- Due to the on hook current requirements there is a limit of two telephones per port on non-boosted battery loops, and one telephone per port on boosted battery loops.
- COMTEL3 Messaging Format:

Table 91: COMTEL3 Messaging Format

Function	RING signal Cadence
Synchronization or Clear	~-----
Ringing	~~~~~
Forwarding	~-~----
Testing	~--~---
Message Waiting	~----~--
Operating Mode	~-----~-
Forwarding and Message Waiting	~-~--~--
Legend: ~ = one cycle of RING signal - = one cycle of space	

Pulse Metering (refer to "[Payphones and Short/Long Loops](#)"):

- The SLMAR board supports pulse metering with either 12KHz tones, 16KHz tones, battery reversal or a combination of tones and battery reversal. Charge pulses using these methods are created on the card by the interface circuitry; no external circuitry or sources are required.
- Tone amplitude, pulse cadencing and mix of tones and battery reversal is country specific and configurable by AMO by means of loadware (refer also to AMO SCSU).
- Soft battery reversal is not supported.

9.2.14.4 Hardware Integrity

The SLMAR board incorporates the same self-test features as the SLMA2 board. In addition to the self-tests performed by the SLMA2 the SLMAR boards, it reports errors as follows:

- DC-to-DC converter failure.
- Loop is too long if configured for pulse metering with tones (refer to [Payphones](#) and [Short/Long Loops](#)). The error message reported is: DC LOOP PROBLEMS (CHECK DEVICE/LINE).

Payphones and Short/Long Loops

Payphones

Some models of terminal devices (payphones and other smart phones) draw loop current while on hook to support resident electronics. They may have rechargeable batteries or capacitors which require charging before the device becomes operational.

These devices should be pre-charged before connection to the SLMAR card to bring the device into service without a long charging interval because the SLMAR card cannot supply high charge current. Some devices, such as the ELASA TPM P/S payphone, may require several hours to recharge using the SLMAR on-hook loop current. During this time the port is not functional.

If a port has been disabled or taken out of service for an extended period of time then the terminal device may require recharging before becoming operational. In extreme cases the terminal device may have lost configuration data and may require re-configuration.

Short/Long Loops

There are three functions which are dependent upon loop length: pulse metering, dc loop current, and voice frequency gain. The crossover loop length between short and long for each function is different, and confusing.

Loop length is defined in terms of dc resistance. This is not a totally accurate way to define the effects of loop length upon the performance of the feature but it is the most easy to measure in the field. The maximum loop resistance supported by the SLMAR board is 3000 Ohms. Because the telephone is not purely resistant, the loop resistance should be calculated using measured values of voltage across the a, b leads at the PBX, and the loop current ($R_{loop} = V_{a-b}/I_{loop}$)

Port Initialization

The loadware resident on the card must determine, through testing, if the loop is too long to support pulse metering with tones (if configured), and if the boosted battery is required to maintain minimum loop current. This test is performed on the first off hook after the port is activated. If any configuration changes are made to a port or if any wiring changes are made which may affect the loop resistance, the port must be deactivated and then activated in order to rerun the test. If this is not done, the port may not be correctly configured.

Pulse Metering

Pulse Metering using 12KHz or 16KHz tones is only supported up to a loop resistance of 1640 Ohms. Above that attenuation of the tones is too great to guarantee proper performance, and battery polarity reversal must be used for signalling. If a port is configured for pulse metering with tones and the loop resistance is too high a configuration error message is sent by loadware to the switch. Selection of pulse metering using tones, battery reversal or both is made using AMO-SCSU.

DC Loop current

The loop current is a constant current feed. If the loop resistance is too high to maintain the programmed constant current using the default -63VDC battery (minimum of 18mA) then boosted battery of +63VDC is switched on. The available DC supply is then +63VDC and

-63VDC. The loop resistance with boosted battery that is required is nominally 2150 Ohms.

When referring to the DC loop feed, short loops of less than 2150 Ohms require regular battery and long loops of over 2150 Ohms require boosted battery of +63VDC and - 63VDC.

Transmission gain

On loops with significant losses the transmission gains or losses are adjusted to ensure correct signalling and voice levels at the PBX and the terminal equipment. This is typically required on loops of greater than 1500-1800 Ohms. The SLMAR ports are configured for short loop transmission gains by default. If the craftsman determines that the loop is too loss-making then the long loop transmission gains may be configured by AMO.

9.2.14.5 Backplane Pin Assignments

[Table 79](#) lists the upper connector backplane pin assignments of the SLMAR board.

Table 92: Pin Assignments Upper Connector

Pin #	Signal Name	Pin #	Signal Name	Pin #	Signal Name
X1-42	NC	X1-22	+5V	X1-2	00A
X1-44	NC	X1-24	GND	X1-4	NC
X1-46	NC	X1-26	00B	X1-6	01A
X1-48	NC	X1-28	NC	X1-8	01B
X1-50	NC	X1-30	NC	X1-10	02A

Pin #	Signal Name	Pin #	Signal Name	Pin #	Signal Name
X2-42	NC	X2-22	NC	X2-2	02B
X2-44	NC	X2-24	NC	X2-4	03A
X2-46	NC	X2-26	GND	X2-6	03B
X2-48	NC	X2-28	NC	X2-8	04A
X2-50	NC	X2-30	NC	X2-10	04B
X3-42	NC	X3-22	NC	X3-2	05A
X3-44	NC	X3-24	NC	X3-4	05B
X3-46	NC	X3-26	GND	X3-6	06A
X3-48	NC	X3-28	NC	X3-8	06B
X3-50	NC	X3-30	NC	X3-10	07A
X4-42	NC	X4-22	-5V	X4-2	07B
X4-44	NC	X4-24	NC	X4-4	NC
X4-46	NC	X4-26	NC	X4-6	NC
X4-48	NC	X4-28	GND	X4-8	NC
X4-50	NC	X4-30	+5V	X4-10	NC

Table 80 lists the pin names for the pre-leading pins.

Table 93: Pre-leading Pins

Pin #	Signal Name
23	GND
27	+5V

Table 81 lists the lower connector backplane pin assignments for the SLMAR board.

Table 94: Pin Assignments Lower Connector

Pin #	Signal Name	Pin #	Signal Name	Pin #	Signal Name
X5-50	NC	X5-30	+5V	X5-10	NC
X6-42	NC	X6-22	GND	X6-2	NC
X6-44	NC	X6-24	GND	X6-4	-48V
X6-46	NC	X6-26	NC	X6-6	NC
X6-48	TOUT*	X6-28	NC	X6-8	NC

Pin #	Signal Name	Pin #	Signal Name	Pin #	Signal Name
X6-50	FBPE	X6-30	NC	X6-10	NC
X7-42	TRST*	X7-22	NC	X7-2	NC
X7-44	TCK*	X7-24	GND	X7-4	NC
X7-46	TMS*	X7-26	PRS	X7-6	BA0
X7-48	TDI*	X7-28	BA1	X7-8	NC
X7-50	TDO*	X7-30	HO1	X7-10	NC
X8-42	HO3	X8-22	HO0	X8-2	NC
X8-44	HO2	X8-24	GND	X8-4	HD0
X8-46	NC	X8-26	BA2	X8-6	BA5
X8-48	NC	X8-28	BA3	X8-8	CKA
X8-50	NC	X8-30	-5V	X8-10	CLS
X9-42	HI3	X9-22	FMB	X9-2	HI1
X9-44	HI2	X9-24	HI0	X9-4	BA4
X9-46	NC	X9-26	GND	X9-6	HDI
X9-48	NC	X9-28	+5V	X9-8	NC

9.2.15 SLMO24

The SLMO24 board has 24 UP0/E interfaces. Up to 3 devices can be connected to the same station line (maximum of three message sources).

The terminals can be supplied with remote power feed by means of the UP0/E-interfaces. The feed voltage can be activated and deactivated separately for every port. Current overload causes an overload protection chip to switch the power off automatically (short-circuit-proof).

For lightning protection see [Section 2.3, "Lightning Protection"](#).

The SLMO24 board supports line termination (LT) for two-wire digital interfaces in accordance with the UP0/E method. Each UP0/E interface is an ISDN basic access (BA) with two B-channels (64 Kbps each) for voice and data transmission and one D-channel (16 Kbps). Terminals with UP0/E interfaces can be connected directly and terminals with S0 interface can be connected by means of a TA-S0 (terminal adapter S0). A maximum of two UP0/E terminals plus supplementary equipment can be connected to each port.

The two B-channels can be switched through to any time slot of the system-side PCM highways. Of all possible D-channel data types (s, p, t), only the s-data (signaling) is processed. It is not planned to support p-data (packet switching) or t-data (telemetry).

The SLMO24 board provides the 24 UP0/E-interface required to support the Optiset E telephones. By using an adapter in the Masterphone (Repeater), you can connect:

- An additional Optiset E telephone (slave phone or terminator) and a LAP-D terminal

OR

- Two LAP-D terminals.

The terminals can be supplied with remote power feed by means of the UP0/E-interfaces.

Figure 82 shows terminals which are connected to the SLMO24 board directly by means of the UP0/E interface or indirectly through an integrated NT.

The system-to-terminal distance depends on the type of cable used. The 1000 m provided in this diagram is considered to be the maximum loop length specified by the Integrated Communications Cabling System (ICCS) without taking power feeding into account.

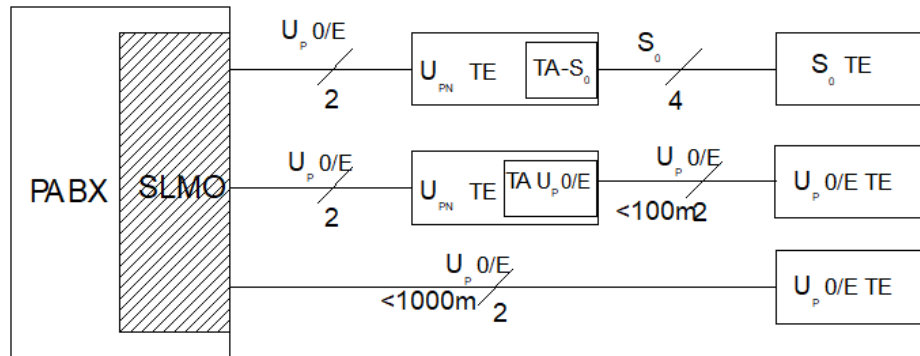

Figure 113: Example of an SLMO Terminal Configuration

9.2.15.1 Board Variants

SLMO24 (24 ports) S30810-Q2168 (predecessor: -Q2158)

SLMOP (24 ports; every line has its own HDLC controller) S30810-Q2169-X100

AMO PETRA

The administration and maintenance operation PETRA enables trace jobs to be installed or stopped for each ACCESS (circuit) on the peripheral SLMO boards. The trace job results can be displayed with the AMO PETRA. In addition this AMO has a memory dump function for the board memories.

9.2.15.2 LED Indications

Table 82 provides the LED indications for the SLMO24 board.

The SLMO24 board front panel has two LEDs.

Table 95: SLMO24 Board LED Indications

Red LED	Green LED	Indications
On	Off	The board has initial power applied.
Flashing	Off	The board is being loaded with loadware.
On	Off	The board is defective or out-of-service.
Off	On	The board is operational and all channels are inactive.
Off	Flashing	The board is operational and one or more channels are active.

9.2.15.3 Removing the SLMO24 Board

IMPORTANT: This procedure removes up to 24 ISDN channels (Optiset E telephones) from service.

NOTICE: Static Sensitive Devices! Observe all precautions for electrostatic discharge.

To remove the SLMO24 board:

1) Deactivate all channels on the board as follows:

a) Type DEA-DSSU and press Enter.

b) Type the following values, then press Enter.

Field	Value
OFFTYPE	DC
TYPE	PEN
PEN1	<PEN1>
PEN2	<PEN2>

IMPORTANT: PEN1 is the pen of the first channel and PEN2 is the pen of the last channel on the board.

2) Display the status of the board until all channels are free as follows:

a) Type DIS-SDSU and press Enter.

b) Type the following values, then press Enter.

Field	Value
STATUS	ALL
LINK	<blank>
TYPE	PEN
LEVEL	PER3
LTG	<1 - 32>
LTU	<1 - 8>
SLOT	<1 - 151>
CCT	<0 - 15>

3) When all channels are free, deactivate the board as follows:

- a) Type `DEA-BSSU` and press Enter.
- b) Type the following values, then press Enter.

Field	Value
<code>OFFTYPE</code>	<code>DC</code>
<code>LTG</code>	<code><1></code>
<code>LTU</code>	<code><1 - 8></code>
<code>SLOT</code>	<code><1 - 121></code>
<code>REFOFF</code>	<code><blank></code>

4) Using the board removal and replacement tool, unseat the board and remove it from the shelf.

9.2.15.4 Replacing the SLMO24 Board

To replace the SLMO24 board:

1) Install the board as follows:

- a) On an LTUE shelf only, install the Adapter 2 on the replacement board
- b) Use one hand to move and hold open the bottom retainer.
- c) Slide the board into the appropriate slot until you seat it firmly into the backplane connector. Do not use the board removal and replacement tool.

2) Activate the SLM board as follows:

- a) Type `ACT-BSSU` and press Enter.
- b) Type the following values, then press Enter.

Field	Value
<code>ONTYPE</code>	<code>AUL</code>
<code>LTG</code>	<code><1 - 32></code>
<code>LTU</code>	<code><1 - 8></code>
<code>SLOT</code>	<code><1 - 151></code>

3) Activate the channels on the board as follows:

- a) Type `ACT-DSSU` and press Enter.
- b) Type the following values, then press Enter.

Field	Value
<code>ONTYPE</code>	<code>AUL</code>
<code>TYPE</code>	<code>PEN</code>
<code>PEN1</code>	<code><PEN1></code>
<code>PEN2</code>	<code><PEN2></code>

IMPORTANT: PEN1 is the pen of the first channel and PEN2 is the pen of the last channel on the board.

9.2.15.5 Verifying the SLM024 Board

To verify the operation of the SLMO24 board, display the status of the board as follows:

- 1) Type `DIS-SDSU` and press Enter.
- 2) Type the following values, then press Enter.

Field	Value
-------	-------

```

STATUS          ALL
LINK            <blank>
TYPE            PEN
LEVEL           PER3
LTG             <1 - 32>
LTU             <1 - 8>
SLOT            <1 - 151>
CCT             <0 - 15>

```

The SLM board is automatically tested on activation.

9.2.15.6 SLMO24 Board MDF Assignments, U.S.

Table 83 shows the standard SLM board punch-down sequence at the MDF.

Cable punch-down is standard. Each channel uses one tip and ring pair. Label the block from channel 00 through 15 or 23, as appropriate.

Table 96: Standard Punch-Down Sequence

Pair No.	Wire Color	Channel No.	Pair No.	Wire Color	Channel No.
1	WHT-BLU BLU-WHT	00	14	BLK-BRN BRN-BLK	13
2	WHT-ORG ORG-WHT	01	15	BLK-SLT SLT-BLK	14
3	WHT-GRN GRN-WHT	02	16	YEL-BLU BLU-YEL	15
4	WHT-BRN BRN-WHT	03	17	YEL-ORG ORG-YEL	16
5	WHT-SLT SLT-WHT	04	18	YEL-GRN GRN-YEL	17
6	RED-BLU BLU-RED	05	19	YEL-BRN BRN-YEL	18
7	RED-ORG ORG-RED	06	20	YEL-SLT SLT-YEL	19
8	RED-GRN GRN-RED	07	21	VIO-BLU BLU-VIO	20
9	RED-BRN BRN-RED	08	22	VIO-ORG ORG-VIO	21
10	RED-SLT SLT-RED	09	23	VIO-GRN GRN-VIO	22
11	BLK-BLU BLU-BLK	10	24	VIO-BRN BRN-VIO	23
12	BLK-ORG ORG-BLK	11	25	VIO-SLT SLT-VIO	Not used.

Pair No.	Wire Color	Channel No.	Pair No.	Wire Color	Channel No.
13	BLK-GRN GRN-BLK	12			

9.2.16 SLMOP

SLMOP: Subscriber Line Module Optimized Performance UP0/E = Digital Subscriber Line Circuit, UP0/E Interface, Improved Performance

The SLMOP board (SLMO-HP boards) is used to solve performance problems in connection with the SLMO24 boards (Q2158 or Q2168) and features such as call pickup group and key functionality.



CAUTION: For lightning protection see [Section 2.3, "Lightning Protection"](#).

The SLMO24 board has been implemented since version V3.4 for connecting Optiset E telephones to the Hicom 300 system. At the moment performance problems occur when call pickup groups with more than 10 subscribers are configured on one board. It is expected that similar restrictions will occur in the future with other signal-intensive features such as key functionality, for example.

The new board will make it possible to improve performance using modified software and by increasing the processor clock pulse. An appropriate hardware concept with faster µP and dedicated HDLC controllers for each port means that the new board will make data throughput 24 times faster.

The only difference between the SLMOP board and the SLMO24 board is the hardware. They are compatible with the SLMO24 and can also replace the SLMO24 board.

Advantages

- More than 10 subscribers per board on one call pickup group
- High usage rate of integrated key functionality
- High performance

9.2.16.1 Basic configuration

- One HDLC controller per port -> terminal units can be connected up with exclusive access to the D channel
- High-performance processor
- Memory, 512 Kbyte flash memory, 236 Kbyte RAM memory for data

9.2.16.2 Range of features

- 24 UP0/E interfaces with -48V power supply
- Function: PABX <---> subscriber telephone
- Power consumption : 4-15 watts (depending on telephone type)
- Module width: 30 mm

- LEDs: 2
- SIPAC backplane connector
- Interface to the MDF
- DELPHI (24 HDLC Controller) and VIP chips (for implementation of the UP0/E interfaces)

9.2.16.3 General operation

- The SLMOP has 24 UP0/E ports and is compatible with the SLMO (-Q2168-X)
- 2-wire interface with a range of at least 1 km:
- Each connection comprises 2 B channels and 1 D channel
- The maximum number of wire pairs that can be connected up is 24

9.2.16.4 Board variants

S30810-Q2169-X100

9.2.16.5 Subscriber Line Module, UP0/E Interface

A maximum of 3 devices can operate on the one subscriber line circuit (maximum of three signal sources).

A remote power supply to the telephones is made possible by means of the UP0/E connections. The supply voltage can be switched on and off for each port. The power is switched off automatically (chip) in the event of an overload (permanent short circuit protection).

The SLMO board has interfaces for 2-wire digital subscriber lines to the UP0/E standard. Each UP0/E interface has a basic ISDN connection with 2 B channels (64 Kbps each) for the transmission of user data as well as a D channel (16 Kbps) for signal data. Telephones with UP0/E interfaces (direct) and telephones with S0 interfaces (with a TA-S0) can be connected to the D channel. A maximum of 2 UP0/E telephones can be connected with their respective auxiliary units for each port.

The B channels can be switched through to any channel (timeslot) of the PCM highways on the system side. Of all D channel signals available (s, p, t), only signaling data is processed. Packet transmission data (p = packet switching) or telemetry (t signals) are not supported.

24 UP0/E interfaces for Symphony telephones. An adapter in the master phone (repeater) can be used to connect up

- Either one additional Symphony telephone (slave phone or terminator) and one LAP-D telephone

OR

- Two LAP-D telephones.

It is possible to supply power from a remote source by means of the UP0/E interfaces.

Figure 83 illustrates the direct connection of telephones to the SLMO by means of the UP0/E interfaces, as well as by means of an integrated network terminal (NT).

The length of the telephone connection lines depends on the type of cable used. The 1000 m specified in the figure below is the maximum loop length in accordance with ICCS (Integrated Communications Cabling System). However, the remote power supply is not taken into account here.

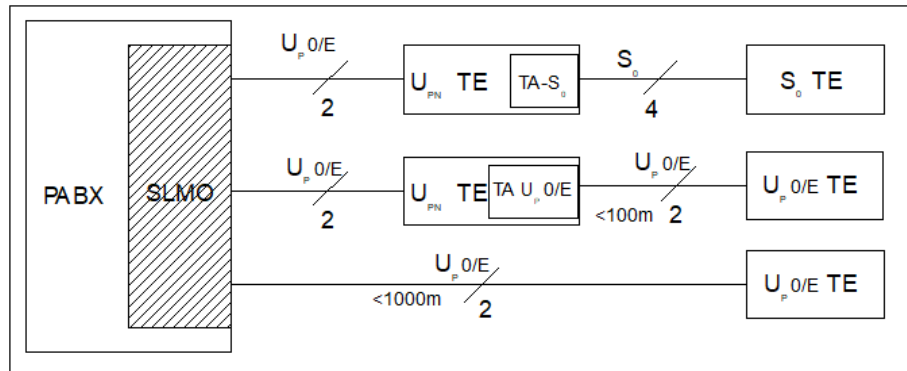

Figure 114: Example of possible SLMO telephone connections

AMO PETRA

Trace processes can be configured or stopped and trace results can be displayed (TRACE) on the peripheral board SLMO and SLMQ for each ACCESS (circuit) with the AMO PETRA. The AMO PETRA also makes it possible to display the contents of the memory on the board (DUMP).

9.2.17 SLMQ

IMPORTANT: The current line card for ANSI-U is the SLMQ Q2153 (2 LEDs, 1 red and 1 green). It replaces the old SLMQ Q2133 (only 1 green LED).

The SLMQ board provides 16 two-wire digital line interfaces according to ANSI-U specifications.



CAUTION: For lightning protection see [Section 2.3, "Lightning Protection"](#).

The SLMQ board also provides ISDN basic access for stations with extremely long lines (5.5 - 9 km). One ANSI-U interface can accommodate either one direct terminal connection, using the appropriate interface plug, or up to 8 S0 terminals. The S0 bus must be connected by means of a PNTQ terminator. An ANSI-U terminal with an integrated PNTQ can accommodate an additional 7 S0 terminal connections.

If the local feed voltage fails, one ANSI-U terminal or one PNTQ plus one S0 terminal per connection can operate on the (remote) emergency feed voltage. Each ANSI-U interface offers ISDN Basic Access with a transmission capacity

of 64 Kbps on each of the two B-channels (voice and data) and 16 Kbps on the D-channel (signaling). The two B-channels can be switched through to any available timeslots of the PCM30 highways in the system. The D-channel only transmits signaling data, exchanged between the ANSI-U interface and the common control (CC).

Figure 84 shows the SLMQ-PNTQ connectivity.

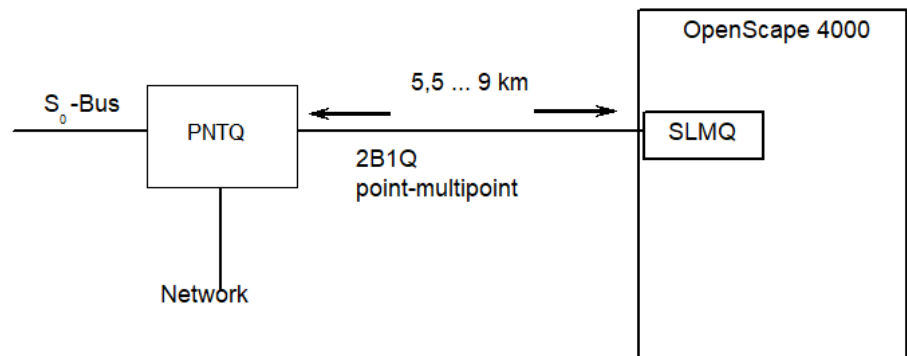

Figure 115: SLMQ, Connecting S0 Terminals By Means of PNTQ Adapter

9.2.17.1 UK0-2B1Q Interfaces

The following terminal types can be connected by means of adapters:

- S0 terminals (by means of PNT-Q)

OR

- One Optiset E telephone for every port (using UCON converter). This is restricted by the UCON adapter.

The UK0-2B1Q interfaces allow remote power feed. The feed voltage can be activated and deactivated per port, and is automatically deactivated if overload current is detected by the control chip (short-circuit proof).

9.2.17.2 SLMQ Board LED Indications

Table 84 provides the LED indications for the SLMQ board.

The SLMQ board front panel contains one LED.

Table 97: SLMQ Board LED Indications

Green LED	Indications
On	The board is loaded; loadware is running.
Off	The board is not operational or not configured.
Flashing	Loadware run is completed (120/120 ms, up to 10 mins.)

9.2.17.3 Removing the SLMQ Board

IMPORTANT: This procedure removes up to 16 ISDN channels from service.

NOTICE: Static Sensitive Devices! Observe all precautions for electrostatic discharge.

To remove the SLMQ board:

1) Deactivate all channels on the board as follows:

- a) Type `DEA-DSSU` and press Enter.
- b) Type the following values, then press Enter.

Field	Value
<code>OFFTYPE</code>	<code>DC</code>
<code>TYPE</code>	<code>PEN</code>
<code>PEN1</code>	<code><PEN1></code>
<code>PEN2</code>	<code><PEN2></code>

IMPORTANT: `PEN1` is the pen of the first channel and `PEN2` is the pen of the last channel on the board.

2) Display the status of the board until all channels are free as follows:

- a) Type `DIS-SDSU` and press Enter.
- b) Type the following values, then press Enter.

Field	Value
<code>STATUS</code>	<code>ALL</code>
<code>LINK</code>	<code><blank></code>
<code>TYPE</code>	<code>PEN</code>
<code>LEVEL</code>	<code>PER3</code>
<code>LTG</code>	<code><1 - 32></code>
<code>LTU</code>	<code><1 - 8></code>
<code>SLOT</code>	<code><1 - 151></code>
<code>CCT</code>	<code><0 - 15></code>

3) When all channels are free, deactivate the board as follows:

- a) Type `DEA-BSSU` and press Enter.
- b) Type the following values, then press Enter.

Field	Value
<code>OFFTYPE</code>	<code>DC</code>
<code>LTG</code>	<code><1></code>
<code>LTU</code>	<code><1 - 8></code>
<code>SLOT</code>	<code><1 - 121></code>
<code>REFOFF</code>	<code><blank></code>

4) Using the board removal and replacement tool, unseat the board and remove it from the shelf.

9.2.17.4 Replacing the SLMQ Board

To replace the SLMQ board:

1) Slide the board into the appropriate slot until you seat it firmly into the backplane connector.

2) Activate the SLM board as follows:

a) Type ACT-BSSU and press Enter.

b) Type the following values, then press Enter.

Field	Value
ONTYPE	AUL
LTG	<1 - 32>
LTU	<1 - 8>
SLOT	<1 - 151>

3) Activate the channels on the board as follows:

a) Type ACT-DSSU and press Enter.

b) Type the following values, then press Enter.

Field	Value
ONTYPE	AUL
TYPE	PEN
PEN1	<PEN1>
PEN2	<PEN2>

IMPORTANT: PEN1 is the pen of the first channel and PEN2 is the pen of the last channel on the board.

9.2.17.5 Verifying the SLMQ Board

To verify the operation of the SLMQ board, display the status of the board as follows:

1) Type DIS-SDSU and press Enter.

2) Type the following values, then press Enter.

Field	Value
STATUS	ALL
LINK	<blank>
TYPE	PEN
LEVEL	PER3
LTG	<1 - 32>
LTU	<1 - 8>
SLOT	<1 - 151>
CCT	<0 - 15>

The SLM board is automatically tested on activation.

9.2.17.6 SLMQ MDF Assignments, U.S.

Table 85 shows the standard SLM board punch-down sequence at the MDF.

Cable punch-down is standard. Each channel uses one tip and ring pair. Label the block from channel 00 through 15 or 23, as appropriate

Table 98: Standard Punch-Down Sequence

Pair No.	Wire Color	Channel No.	Pair No.	Wire Color	Channel No.
1	WHT-BLU BLU-WHT	00	14	BLK-BRN BRN-BLK	13
2	WHT-ORG ORG-WHT	01	15	BLK-SLT SLT-BLK	14
3	WHT-GRN GRN-WHT	02	16	YEL-BLU BLU-YEL	15
4	WHT-BRN BRN-WHT	03	17	YEL-ORG ORG-YEL	16
5	WHT-SLT SLT-WHT	04	18	YEL-GRN GRN-YEL	17
6	RED-BLU BLU-RED	05	19	YEL-BRN BRN-YEL	18
7	RED-ORG ORG-RED	06	20	YEL-SLT SLT-YEL	19
8	RED-GRN GRN-RED	07	21	VIO-BLU BLU-VIO	20
9	RED-BRN BRN-RED	08	22	VIO-ORG ORG-VIO	21
10	RED-SLT SLT-RED	09	23	VIO-GRN GRN-VIO	22
11	BLK-BLU BLU-BLK	10	24	VIO-BRN BRN-VIO	23
12	BLK-ORG ORG-BLK	11	25	VIO-SLT SLT-VIO	Not used.
13	BLK-GRN GRN-BLK	12			

9.2.18 SLMQ3

This section describes the function of the subscriber line module U2B1Q (SLMQ3) board. It also provides procedures for removing, replacing, and verifying this board.



CAUTION: For lightning protection see [Section 2.3, "Lightning Protection"](#).

9.2.18.1 Functional Description

The SLMQ3 board is a 16-channel board that supports the National ISDN 2 (NI-2) protocol. It provides the U2B1Q interface required to support the connection of the following types of devices:

- Optiset NI-1200U telephone
- Distance adapter, which permits the connection of the Optiset E
- A network termination 1 (NT-1) device

The SLMQ3 board can also support the connection of the Optiset NI-1200S by way of:

- A TA/ST module installed in the NI-1200U
- An NT-1 device

The SLMQ3 board uses the standard punch-down sequence

Figure 85 and Figure 86 show examples of SLMQ3 connectivity.

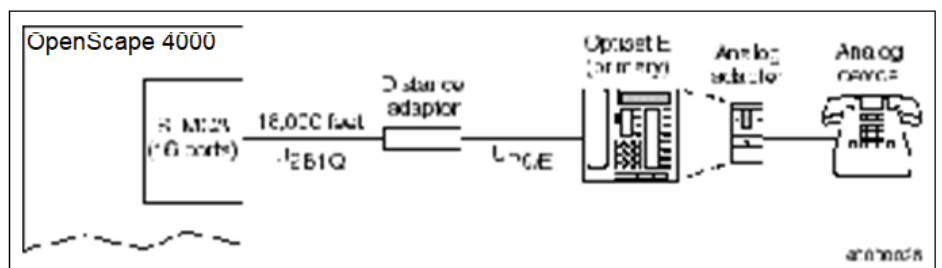

Figure 116: SLMQ3 Connectivity Example 1

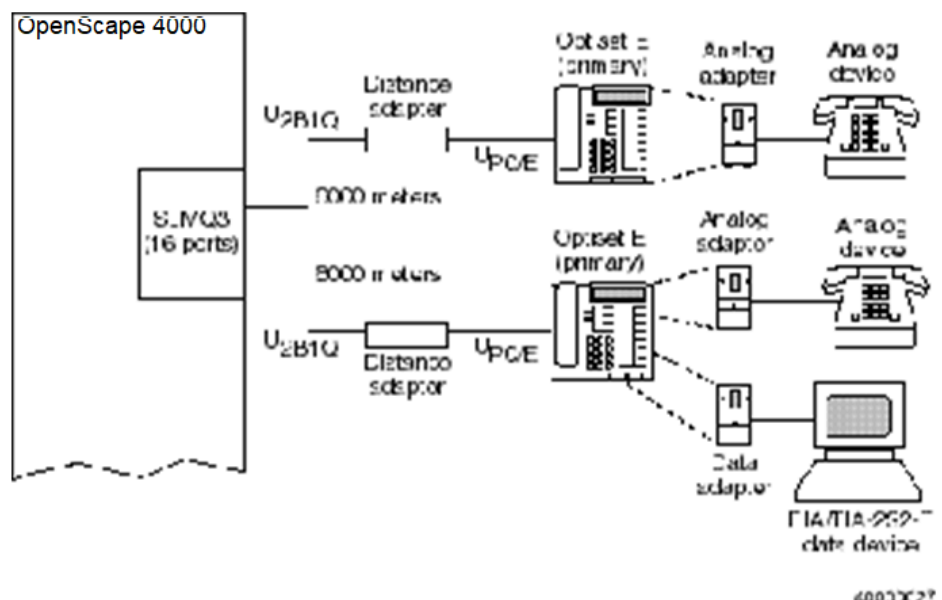

Figure 117: SLMQ3 Connectivity Example 2

9.2.18.2 LED Indications

The SLMQ3 board front panel contains two LEDs. [Table 86](#) lists the LED indications for the SLMQ3 board.

Table 99: SLM Board LED Indications

Red LED	Green LED	Indications
On	Off	The board has initial power applied.
Flashing	Off	The board is being loaded with loadware.
On	Off	The board is defective or out-of-service.
Off	On	The board is operational and all channels are inactive.
Off	Flashing	The board is operational and one or more channels are active.

9.2.18.3 Removing the SLMQ3 Board

IMPORTANT: This procedure removes up to 16 ISDN channels from service.

NOTICE: Static Sensitive Devices! Observe all precautions for electrostatic discharge.

Remove the SLMQ3 board as follows:

1) Deactivate all channels on the board as follows:

- a) Type `DEA-DSSU` and press Enter.
- b) Type the following values, then press Enter.

Field	Value
OFFTYPE	DC
TYPE	PEN
PEN1	<PEN1>
PEN2	<PEN2>

IMPORTANT: PEN1 is the pen of the first channel and PEN2 is the pen of the last channel on the board.

2) Display the status of the board until all channels are free as follows:

- a) Type `DIS-SDSU` and press Enter.
- b) Type the following values, then press Enter.

Field	Value
STATUS	ALL
LINK	<blank>
TYPE	PEN

LEVEL	PER3
LTG	<1 - 32>
LTU	<1 - 8>
SLOT	<1 - 151>
CCT	<0 - 15>

3) When all channels are free, deactivate the board as follows:

a) Type `DEA-BSSU` and press Enter.

4) Type the following values, then press Enter.

Field	Value
OFFTYPE	DC
LTG	<1>
LTU	<1 - 8>
SLOT	<1 - 121>
REFOFF	<blank>

9.2.18.4 Replacing SLMQ3 Board

Replace the SLMQ3 board as follows:

1) Slide the board into the appropriate slot until you seat it firmly into the backplane connector.

2) Activate the SLMQ3 board as follows:

a) Type `ACT-BSSU` and press Enter.

b) Type the following values, then press Enter.

Field	Value
ONTYPE	AUL
LTG	<1 - 32>
LTU	<1 - 8>
SLOT	<1 - 151>

3) Activate the channels on the board as follows:

a) Type `ACT-DSSU` and press Enter.

b) Type the following values, then press Enter.

Field	Value
ONTYPE	AUL
TYPE	PEN
PEN1	<PEN1>
PEN2	<PEN2>

IMPORTANT: PEN1 is the pen of the first channel and PEN2 is the pen of the last channel on the board.

9.2.18.5 Verifying the SLMQ3 Board

Verify the operation of SLM boards by displaying the status of the board as follows:

1) Type `DIS-SDSU` and press Enter.

2) Type the following values, then press Enter

Field	Value
STATUS	ALL

```

LINK           <blank>
TYPE          PEN
LEVEL        PER3
LTG          <1 - 32>
LTU          <1 - 8>
SLOT        <1 - 151>
CCT         <0 - 15>
    
```

The SLM board is automatically tested on activation.

9.2.18.6 MDF Assignments

The SLMQ3 board punch-down sequence is standard. Each channel uses one tip and ring pair. Label the block from channel 00 through 15 or 23, as appropriate.

Table 87 lists the standard SLM board punch-down sequence at the MDF.

IMPORTANT: The SLMQ3 board supports the connection of NI-2 telephones at distances up to 18,000 ft. Digital stations in a campus environment that require the use of exposed wiring (aerial cable or buried cable) must include overcurrent protective wiring systems.

Table 100: Standard Punch-Down Sequence

Pair No.	Wire Color	Channel No.	Pair No.	Wire Color	Channel No.
1	WHT-BLU BLU-WHT	00	14	BLK-BRN BRN-BLK	13
2	WHT-ORG ORG-WHT	01	15	BLK-SLT SLT-BLK	14
3	WHT-GRN GRN-WHT	02	16	YEL-BLU BLU-YEL	15
4	WHT-BRN BRN-WHT	03	17	YEL-ORG ORG-YEL	16
5	WHT-SLT SLT-WHT	04	18	YEL-GRN GRN-YEL	17
6	RED-BLU BLU-RED	05	19	YEL-BRN BRN-YEL	18
7	RED-ORG ORG-RED	06	20	YEL-SLT SLT-YEL	19
8	RED-GRN GRN-RED	07	21	VIO-BLU BLU-VIO	20
9	RED-BRN BRN-RED	08	22	VIO-ORG ORG-VIO	21

Pair No.	Wire Color	Channel No.	Pair No.	Wire Color	Channel No.
10	RED-SLT SLT-RED	09	23	VIO-GRN GRN-VIO	22
11	BLK-BLU BLU-BLK	10	24	VIO-BRN BRN-VIO	23
12	BLK-ORG ORG-BLK	11	25	VIO-SLT SLT-VIO	Not used.
13	BLK-GRN GRN-BLK	12			

9.2.19 STHC

The subscriber trunk hybrid card (STHC) board has the combined functionality of the STMD and SLMO boards.



CAUTION: For lightning protection see [Section 2.3, "Lightning Protection"](#).

9.2.19.1 Feature Characteristics

The STHC board optimizes peripheral cards for small configuration and combines the functionality of several cards into one card to free up slots. You can operate the STMD and SLMO cards with the new STHC. The STHC requires 4 S0 and 16 UP0E interfaces. The assignment of ports to the STMD and SLMO24 functions are defined and can be configured.

[Figure 87](#) shows a connectivity diagram of the terminals to the STHC board.

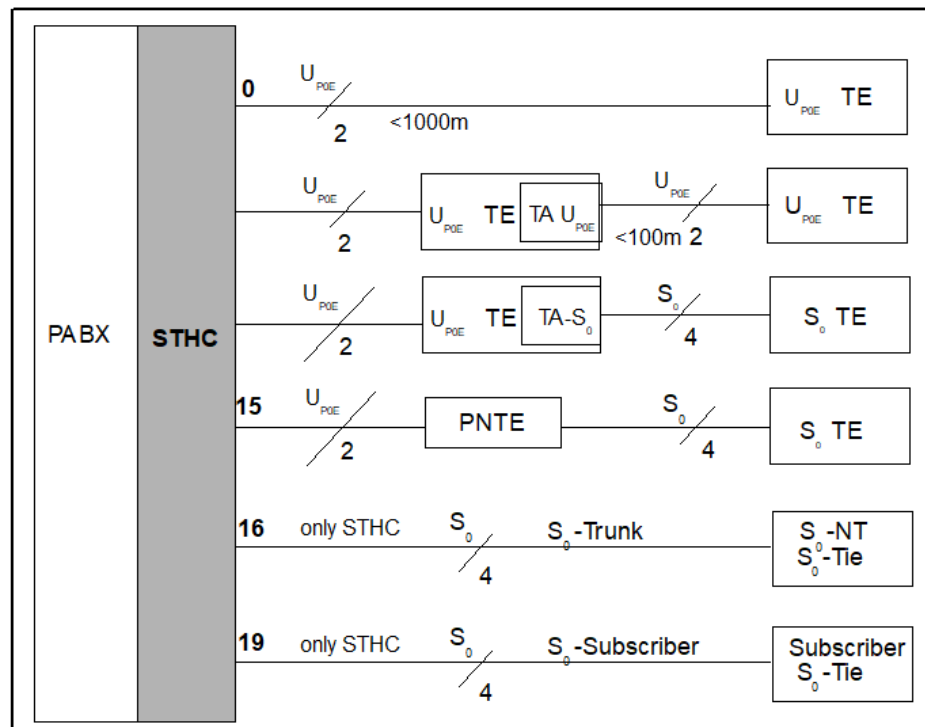

Figure 118: Connection of Terminals to the STHC Board

The STHC board provides digital UP0E and S0 interfaces.

9.2.19.2 UP0E Interface

The STHC board is equipped with the following:

- Digital 2-wire interface
- Terminal with UP0E or S0 can be connected by means of TA-S0
- -48V remote feeding by means of UP0E
- Maximum cable length approximately 1000 m
- High performance capability
- Only function ID 1 is supported (no routing and remote functionality)

9.2.19.3 S0 Interface

The STHC board is equipped with the following:

- Digital 4-wire interface

- Trunk/subscriber mode
 - Details in the trunk mode:
 - Maximum cable length in trunk mode for approximately 1000 m
 - Reference clock derived in the trunk mode (TMD) at any selected S0 interface
 - No -40-V feeding
 - Only point-to-point traffic is supported.
 - Details in the subscriber mode:
 - Maximum cable length in the subscriber mode
 - Extended bus: approximately 500 m
 - Short bus: approximately 150 m
 - Both traffic types, point to point and point to multipoint are supported.

9.2.19.4 Board Variants

S30810-Q2177-X (will be replaced by Q2169-X)

S30810-Q2169-X

9.2.20 STMA

The subscriber trunk module asynchronous transfer mode (STMA) board provides connectivity between an OpenScape 4000 or a Hicom 300E/H V6.5 or later U.S. system and an ATM network. Depending on which STMA board feature is implemented, a system equipped with an STMA board uses either the CorNet-N or CorNet-NQ private networking protocol to interface with the ATM network. The system does not limit the number of STMA boards it can support except for the limits imposed by the performance capacity of the system.



CAUTION: For lightning protection see [Section 2.3, "Lightning Protection"](#).

An STMA board:

- Requires a OpenScape 4000 or Hicom 300 E/H V6.5 or later system software
- Uses SIPAC connectors. Use an Adapter 2 (SIPAC-to-SIVAPAC adapter) to adapt an STMA board for a SIVAPAC shelf.
- Provides 92 configurable channels. The STMA board has the capacity of four TMDN boards (96 channels), but only 92 channels are configurable.
- Plugs into any peripheral slot. An STMA board is not supported on an RCM or RCMX shelf.
- Provides fiber optic ATM connectivity. An STMA provides a fiber optic interface for connectivity to an ATM network.

An STMA board comes in two orderable variants. The variants differ only in the type of fiber optic interface they use. Both boards have OC-3C fiber optic

devices that serially transmit at 155 Mbps, but the transmission ranges for the two devices differ. The variants are as follows:

- STMA board with single-mode fiber optic interface (STMA-S)
- This variant provides a maximum range of 15.5 miles (25 km) for fiber optic transmissions.
- STMA board with multimode fiber optic interface (STMA-M)
- This variant provides a maximum range of 1.24 miles (2 km) for fiber optic transmissions.

9.2.20.1 Features

An STMA board has the following configurable features:

- Backboning

Using CorNet-N protocol, the backboning feature enables an ATM network backbone to be used as a link between V6.5 or later systems. A V6.5 or later system can use this feature for transparent call connections with other systems across an ATM network. Each STMA board provides four backboning ports. [Figure 88](#) shows an example of the backboning feature.

- Interworking

Using CorNet-NQ protocol, the interworking feature enables service-specific dial-up connections between V6.5 or later system subscribers and ATM subscribers. In addition, it can provide individual transit connections between V6.5 or later system subscribers over an ATM network. Calls are limited to basic call functions; consequently, call features are not supported. Each STMA board provides four interworking ports. [Figure 89](#) shows an example of the interworking feature.

Each STMA board can support only one feature at a time, depending on how the board is configured. Both the backboning and the interworking

features can reside in the same system, but individual STMA boards cannot be shared between the two features.

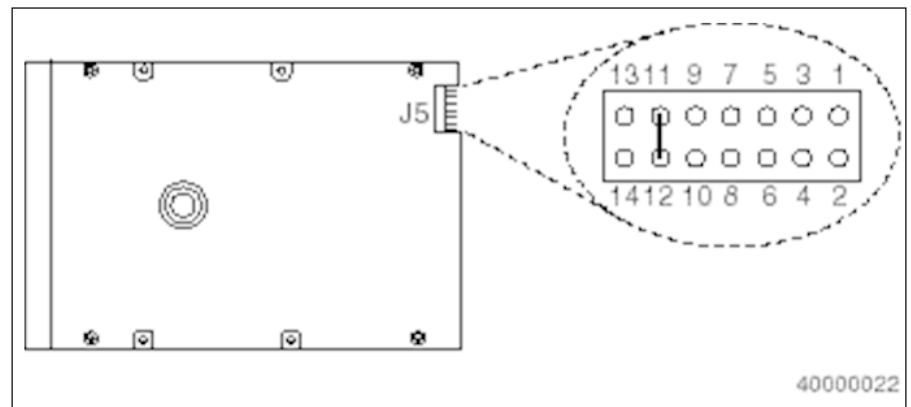

Figure 119: Example of the Backboning Feature

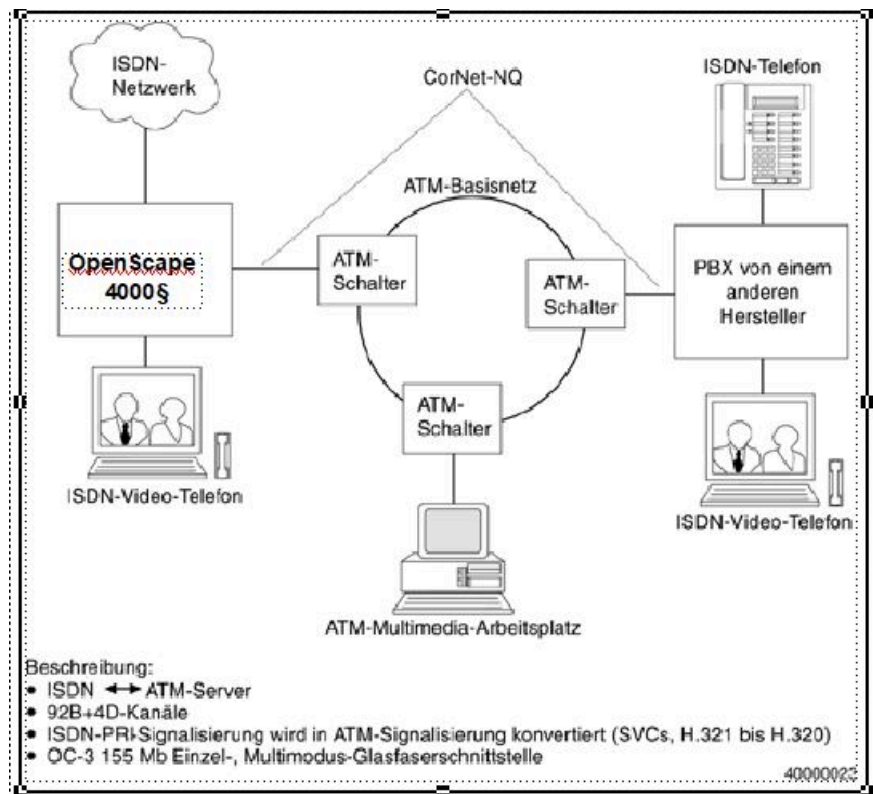

Figure 120: Example of the Interworking Feature

9.2.20.2 LED Indications and Connector

The front panel of the STMA board (see [Figure 90](#)) has LED indicators and a fiber optic connector.

- Red and green LED indicators provide error and status information (for details, refer to [Table 88](#)).
- The fiber optic connector provides connectivity to the ATM network

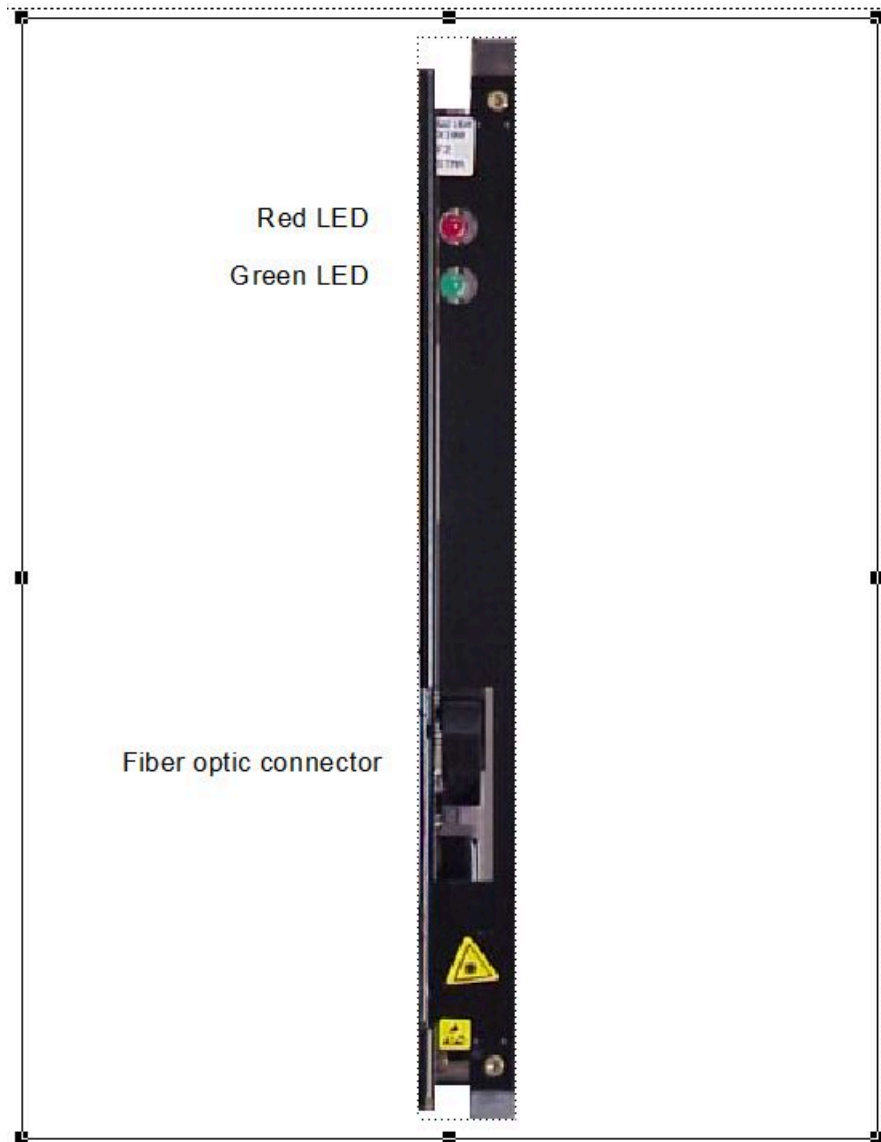

Figure 121: STMA Board Front Panel

[Table 88](#) lists the LED indications for an STMA board.

Table 101: STMA Board LED Indications

Red LED	Green LED	Indication
On	Off	The board has initial power applied.
Flashing	Off	The board is being loaded with loadware.
On	Off	The board is defective or out-of-service
Off	On	The board is operational and all channels are inactive.
Off	Flashing	The board is operational and one or more channels are active.

9.2.20.3 Removing the STMA Board



DANGER: Do not look directly at the fiber optic receptacle on the STMA board with single-mode fiber optic interface when the board is powered on. This device uses laser technology that can cause eye damage when looked at directly.



CAUTION: Fiber optic cable can easily be damaged. Do not bend the cable sharply or tie it down too tightly.

IMPORTANT: Because this procedure removes the STMA board from service it prevents clients dependent on this board from using the ATM networking feature.

NOTICE: Attention: Static Sensitive Devices! Observe all precautions for electrostatic discharge.

IMPORTANT: You must use the board removal and replacement tool for boards installed in metal card guides.

To remove the STMA board from a OpenScape 4000:

1) Deactivate all channels on the board as follows:

- a) Type `DEA-DSSU`, then press Enter.
- b) Type the following values, then press Enter.

Field	Value
OFFTYPE	DC
TYPE	PEN
PEN1	<PEN1>
PEN2	<PEN2>

IMPORTANT: PEN1 is the PEN of the required D channel, and PEN2 is not used. If all four spans are used, then all four D channels must be deactivated. The D channels are numbered as 24, 49, 74, and 99. Using the PEN2 parameter to indicate a range of PENS is not allowed.

2) Display the status of the board until all channels are free as follows:

- a) Type `DIS-SDSU`, then press Enter.
- b) Type the following values, then press Enter.

Field	Value
LINK	<blank>
LTG	<1 - 32>
LTU	<1 - 8>
SLOT	<1 - 151>
CCT	<0 - 15>

3) When all channels are free, deactivate the board as follows:

- a) Type `DEA-BSSU`, then press Enter.
- b) Type the following values, then press Enter.

Field	Value
<code>OFFTYPE</code>	<code>D1</code>
<code>LTG</code>	<code><1></code>
<code>LTU</code>	<code><1 - 15></code>
<code>SLOT</code>	<code><1 - 121></code>
<code>REFOFF</code>	<code><blank></code>
<code>SPAN</code>	<code><1 - 4></code>

IMPORTANT: All four spans, if configured, must be deactivated.

- 4) Disconnect the ATM network cable from the fiber optic interface receptacle on the front of the board.
- 5) Using the board extractor, unseat the board and remove it from the shelf.

9.2.20.4 Replacing the STMA Board



CAUTION: Fiber optic cable can easily be damaged. Do not bend the cable sharply or tie it down too tightly.



DANGER: Do not look directly at the fiber optic receptacle on the STMA board with single-mode fiber optic interface when the board is powered on. This device uses laser technology that can cause eye damage when looked at directly.

To replace the STMA board in a OpenScape 4000:

- 1) Slide the board into the appropriate slot until it seats firmly into the backplane connector.
- 2) Plug the ATM network cable into the fiber optic interface receptacle on the front of the board.
- 3) Activate the board as follows:
 - a) Type `ACT-BSSU` and press Enter.
 - b) Type the following values, then press Enter.

Field	Value
<code>ONTYPE</code>	<code>AUL</code>
<code>LTG</code>	<code><1></code>
<code>LTU</code>	<code><1 - 15></code>
<code>SLOT</code>	<code><1 - 121></code>
<code>SPAN</code>	<code><1 - 4></code>

IMPORTANT: All four spans, if configured, must be deactivated.

4) Activate the channels on the board as follows:

a) Type `ACT-DSSU` and press Enter.

b) Type the following values, then press Enter.

Field	Value
ONTYPE	AUL
TYPE	PEN
PEN1	<PEN1>
PEN2	<PEN2>

IMPORTANT: PEN1 is the PEN of the required D channel, and PEN2 is not used. If all four spans are used, then all four D channels must be activated. The D channels are numbered as 24, 49, 74, and 99. Using the PEN2 parameter to indicate a range of PENS is not allowed.

9.2.20.5 Verifying the STMA Board

To verify the operation of the STMA board, display the status of the board as follows:

1) Type `DIS-SDSU` and press Enter.

2) Type the following values, then press Enter.

Field	Value
LINK	<blank>
LTG	<1 - 32>
LTU	<1 - 15>
SLOT	<1 - 151>
CCT	<blank>

The board is automatically tested on activation.

9.2.21 STMD

IMPORTANT: The STMD Q2174 has been replaced by STMD2 Q2163-X.

The subscriber trunk module digital S0 (STMD) board comprises the trunk module digital (TMD) and station line module digital (SMD) function on one single board. It contains eight trunks with S0 interfaces.



CAUTION: For lightning protection see [Section 2.3, "Lightning Protection"](#).

- TMD Mode

In TMD mode, the board allows the OpenScape 4000 to connect to standardized, four-wire S0 interfaces which may either be fed by an ISDN exchange or an ISDN PABX.

In TMD mode, the STMD provides a reference clock (derived from the S0 path clock) which can be used to synchronize the system clock generator.

- SMD Mode

In SMD mode, the board implements the basic ISDN S0 access for terminal equipment (TE). The behavior corresponds to that of the network terminator (NT). Only point-to-point operation is supported. Feeding of connected terminals is not provided.

Each S0 port is a basic access with a transmission capacity of two B-channels (64 Kbps each) for voice/data and one D-channel (16 Kbps).

The two B-channels can be optionally switched to time slots of the system PCM highways. s data (signaling) and p data (packet switching) of the available D-channel data types (s, p, t) is handled. They are exchanged between S0 interface and common control or packet handler. Maximum line length (to NT): 1000 m (3281 ft.).

9.2.21.1 LED Indications

The front panel of the board contains 8 LEDs (see [Table 89](#)).

Table 102: STMD Board LED Indications

Startup	
All LEDs on	After loading board: loadware startup
All LEDs blink (120/120 ms, max. 10 min)	End of loadware startup
All LEDs off	Loading the line data
Operating State	
LED on	Layer 2 (L2) active
LED off	Layer 2 (L2) deactivated
LED blinks slowly (1, 2/1, 2 s)	Trunk providing reference clock
Error Events	
LED blinks rapidly (300/900 ms)	Layer 1 (L1) error
LED double blinking (300/300/300/900 ms)	Layer 2 (L2) error
All LEDs blink rapidly (300/900 ms)	Board error

9.2.21.2 Board Variants

STMD Q2174-X

9.2.21.3 Board Functions

Integrity counters maintain statistics for layer 2 protocols on the S0/S2 interface. The statistics can be analyzed using AMO BSSU.

9.2.21.4 Configuring the STMD Board Using AMOs

The AMOs used for configuring the STMD board are as follows:

- AMO SBSU
- AMO BSSU
- AMO DIMSU
- AMO REFTA
- AMO PRODE

Figure 91 and Figure 92 shows STMD board connectivity diagrams.

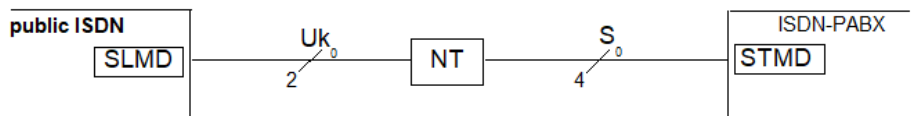

Figure 122: Connection PABX - Exchange (STMD)

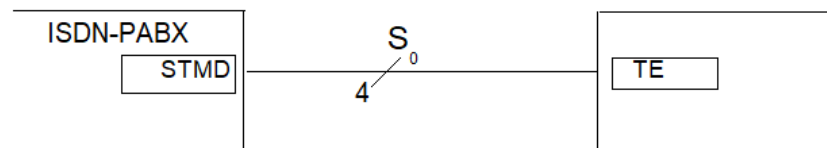

Figure 123: Connection PABX - Terminal (STMD)

9.2.21.5 PIN Assignments

Table 90 lists the pin assignments for the upper connector of the STMD board. The third row of the upper and the lower connector is not used.

Table 103: Upper STMD connector

Pin no.	Designation	Description
01 X	A0	a-wire 0 (STMD0) -r-
02	+12 V	positive electronic voltage
03 X	A1	a-wire 1 (STMD0) -t-
04 X	B1	b-wire 1 (STMD0) -t-
05 X	A2	a-wire 2 (STMD1) -r-
06 X	B2	b-wire 2 (STMD1) -r-

Pin no.	Designation	Description
07 X	A3	a-wire 3 (STMD1) -t-
08 X	B3	b-wire 3 (STMD1) -t-
09 X	A4	a-wire 4 (STMD2) -r-
10 X	B4	b-wire 4 (STMD2) -r-
11 X	A5	a-wire 5 (STMD2) -t-
12 X	B5	b-wire 5 (STMD2) -t-
13 X	A6	a-wire 6 (STMD3) -r-
14 X	B6	b-wire 6 (STMD3) -r-
15 X	A7	a-wire 7 (STMD3) -t-
16 X	B7	b-wire 7 (STMD3) -t-
17 X	A8	a-wire 8 (STMD4) -r-
18 X	B8	b-wire 8 (STMD4) -r-
19 X	A9	a-wire 9 (STMD4) -t-
20 X	B9	b-wire 9 (STMD4) -t-
X Pins seized by the STMD board -t- transmit -r- receive		

Table 91 lists the pin assignments for the lower connector of the STMD board.

Table 104: Lower STMD connectors

Pin Number	Designation	Description
201	RING	25 Hz AC voltage
202	+12 V	Positive electronic voltage
203	-48 V	Feed voltage
204	-60 V	Feed voltage
205	+60 V	Positive feed or signaling voltage
206		
207 X	RCLK	Reference clock line
208 X	RAC	Reference clock activation line
209 X	BA0	Board address bit no. 0
210	UW1-S	Presence 25 Hz

Pin Number	Designation	Description
211	UW1-T	Presence 50 Hz
212 X	BA6	Board address bit no. 6
213 X	HD0	HDCL channel output from system
214 X	BA5	Board address bit no. 5
215 X	CKA	System clock, (2,048 od. 4,096 MHz)
216 X	CLS	Clock select (CKA selektion)
217 X	SPHIB	Voice channel B-input to system
218 X	BA4	Board address bit no. 4
219 X	HDI	HDCL channel input to system
220	-12 V	Negative electronic voltage
221 X	+5 V	Positive elektronik voltage
222 X	GNDE	Electronic ground
223	GNDB	System ground
224	UA1-T	50 Hz AC voltage
225	UA2-T	(Without ground reference)
226	SYNR. 50 Hz	Synchronization signal 50 Hz
227	SYNR. 25 Hz	Synchronization signal 25 Hz
228 X	GNDE	Electronic ground
229 X	PRS	Reset/peripheral reset
230 X	BA1	Board address bit 1
231 X	SPHO B	Speech channel B-output from system
232 X	SPHO A	Speech channel A-output from system
233 X	GNDE	Electronic ground
234 X	BA2	Board address bit 2
235 X	BA3	Board address bit 3
236	-5 V	Negative electronic voltage
237 X	FMB	Frame synchronization pulse
238 X	SPHIA	Speech channel A-input to system

Pin Number	Designation	Description
239 X	GNDE	Electronic ground
240 X	+5 V	Positive electronic voltage
X Pins seized by the STMD module		

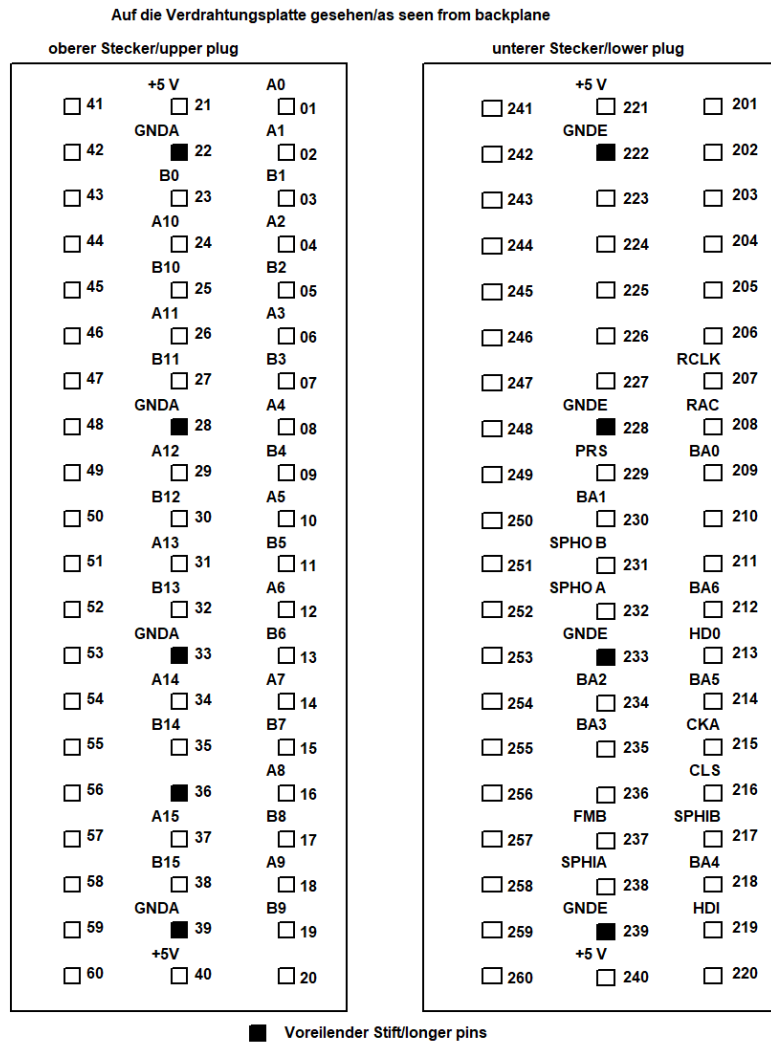

Figure 124: STMD Connector Assignment

9.2.22 STMD2

The hardware description for STMD2 is the same as STMD3. Please check [Section 6.7, "STMD3"](#) for further information.

9.2.23 STMI4

The STMI4 (Subscriber Trunk Module IP 4) board is used as Common Gateway HG 3500.



CAUTION: For lightning protection see [Section 2.3, "Lightning Protection"](#).

The STMI4 board offers the following central and peripheral functions:

- Two network accesses to 100 Base-T Fast Ethernet
 - Voice encoding functions (based on DSP)
 - Backplane interface for a default peripheral board
 - V.24 interface for test access (service interface)
-

IMPORTANT: The STMI4 is allowed to be hot plugged.

[Figure 94](#) shows the STMI4 board.



Figure 125: STMI4 board

9.2.23.1 System Diagram

[Figure 95](#) shows a system diagram of the STMI4 board.

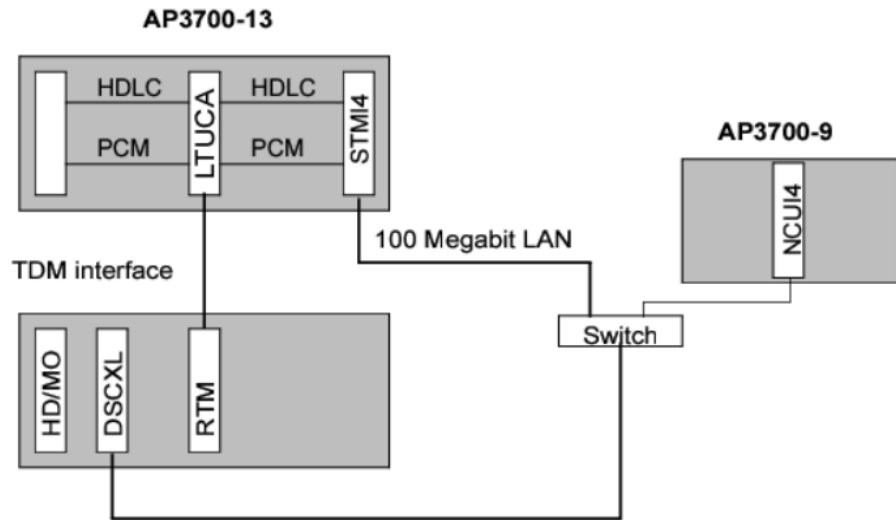

Figure 126: STMI4 Board, System Diagram

9.2.23.2 Board Variants and Modules

(S30810-Q2324-X500/X511)

Table 105: STMI4 - Board variants and modules

STMI4 without a PDMX (PMC DSP Module Extended):	S30810-Q2324-X500 (60-channel version)
STMI4 with a PDMX (PMC DSP Module Extended):	S30810-Q2324-X511 (120-channel version)

PMC = PCI Mezzanine Card

The STMI4 features one Gateway Accelerator slot.

9.2.23.3 LED Displays and Interfaces

Table 93 lists the LED displays and interfaces that are configured on the front of the board for service purposes:

Table 106: LED Displays and Interfaces

Quantity	LEDs and interfaces	Indications and Purpose
1	V.24 9-pin SUB-D connector	For testing
1	Green LED	Run or Active status
1	Red LED	Fail status

Quantity	LEDs and interfaces	Indications and Purpose
2	LEDs: LED1: green On = 100 Mbps	For each LAN interface (integrated in the RJ45 connector)
	LED2: green green = online (link) wink = active	On = full-duplex (FDX); Off = half-duplex

Figure 96 shows the STMI4 board front panel.

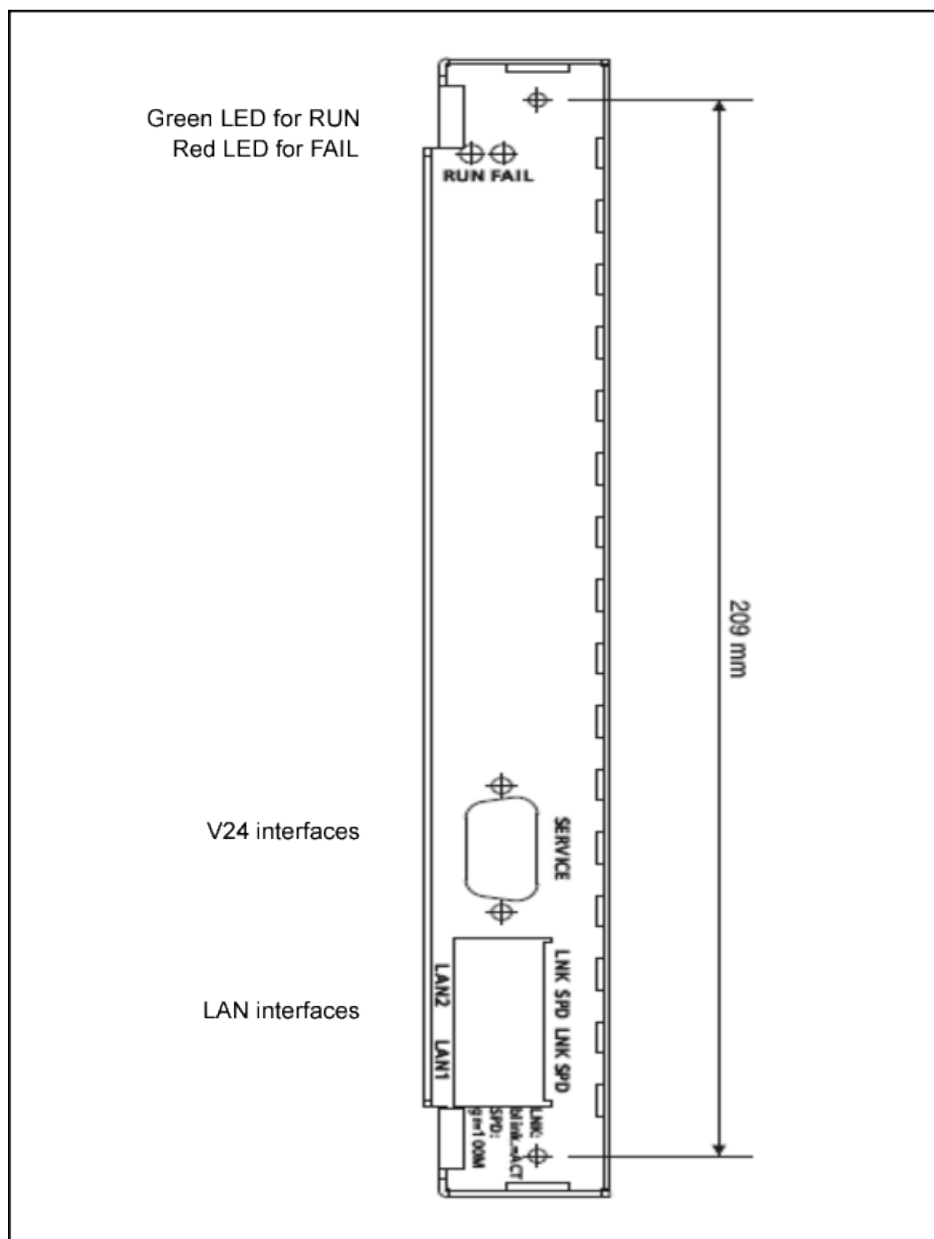

Figure 127: STMI4 Board, Front Panel

9.2.23.4 Power Supply

The STMI4 board receives a power supply voltage of +5 V over the backplane. The individual voltages required (+3.3 V, +2.5 V, +1.8 V and 1.2 V) are generated by the DC-to-DC converter on the board. The board is automatically reset if one of the voltages falls below the critical value.

9.2.24 TM2LP

The universal analog trunk module (TM2LP) board offers a twin-wire interface to analog public trunks and operates using the loop procedure.



CAUTION: For lightning protection see [Section 2.3, "Lightning Protection"](#).

- Outgoing traffic: direct
- Incoming traffic: by means of attendant console (MSI), direct inward dialling (DID)
- Bothway traffic
- Dial Signalling method: DP, DTMF and MFC-R2 (method configurable per circuit)

The TM2LP board has access to four highways, two of which are supported by loadware. The board includes the necessary circuitry to support loop closure or monitoring for call detection (loop or reversal polarity) and call charge detection for up to 8 ports.

The analog speech paths are converted to the internal OpenScape 4000 digital display (and vice-versa) using an A/D Converter and analog elements implemented in accordance with country-specific transmission technology providing a large range of interface matching for each standard of countries.

A μ P MC68340 with 512 KB Flash EPROM and 256 KB SRAM, together with two C509-L as preprocessors are used for interpreting system commands and processing line signals changing the old 8051 platform as CPU to the 16-bit data bus and 24-bit address bus microprocessor platform.

Selection of the call charge frequency to be detected depends on the board variant.

- 50 Hz call detail recording: variants X130, X140, X160 -X190.
- 12 kHz call detail recording: variants X160 and X180.
- 16 kHz call detail recording: variants X130 - X150 and X190.
- Special variants for DID/DOD signaling: X100 - X120.

The following essential properties characterize the new TM2LP board:

- Same functionality as the discontinued board in each case (refer to [Table 94](#))
- Eight ports per board
- Protection on the board
- SIPAC backplane connector
- Two LEDs

The board gradually replaces the following boards and variants:

Table 107: Boards Replaced by the TM2LP Board

TMCOW	Q2288	All variants	MSI
TMLRP	Q2131	One variant	MSI
TMLRP	Q2134	Two variants	MSI
TMLSL	Q2073	One variant	DID Belgium
TMGSR	Q2075	One variant	MSI
TMLRS	Q2188	One variant	MSI
TMAS8	Q2167	One variant	DID/DOD Austria
TMLSR	Q2173	One variant	DID Italy

Table 95 lists the boards that have already been replaced by various TMCOW variants:

Table 108: Boards Replaced by TMCOW Variants

TMLRW	Q2088	One variant
TMEDG	Q2172	One variant
TMELS	Q2272	One variant

9.2.24.1 Board Variants

Q2159-X100; ... X110-X190

The individual hardware variants meet country-specific standards for AC connection.

Variants X180 (with 12 kHz call detail recording) and X190 (with 16 kHz call detail recording) comply with European TBR21 guidelines.

9.2.24.2 Loadware Variants

No Variants: PZGTM2L0

In analog interfaces normally each country or customer uses a private protocol to connect to Central Office. Thus the Loadware provides a possibility to adapt the signaling protocol specific for each country.

With the new HW platform using a Motorola microprocessor and a new LW Platform this analog interface offers a greater flexibility to comply the previous boards functionality converging in one.

9.2.24.3 Configuration Example for Switzerland

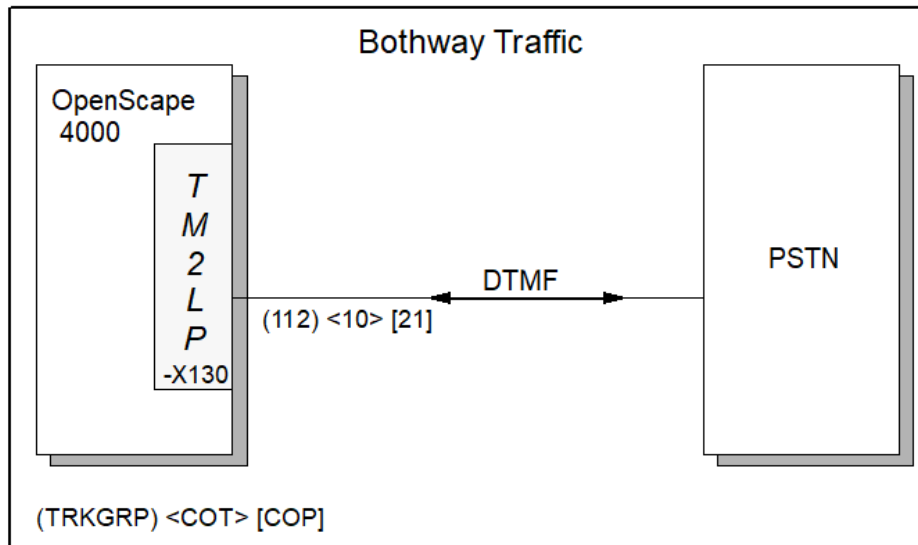

Figure 128: Configuration Example for Switzerland

The following steps show an example of configuring the TM2LP Card. It is not valid for all conditions.

AMO-BCSU:

- Configuring Mounting Locations for TM2LP (Q2159-X130) module in the SWU:
`ADD-BCSU: PER, <LTG>, <LTU>, <SLOT>, "Q2159-X130", 0;`
- SIU2 configuration for DTMF outgoing Traffic:
`ADD-BCSU:SIUP, <LTG>, <LTU>, <SLOT>, "Q2031-X 1"`

AMO-BUEND:

`ADD-BUEND: 112, "HKZ-DTMF ", 10, N;`

AMO-WABE:

`ADD-WABE: 131, , , TIE;`

AMO-COSSU:

<code>ADD-COSSU: ,10, TA &</code>	(Auth. for unrestricted long-distance service)
<code>TNOTCR</code>	(Tie trunk without toll code restriction)
<code>&</code>	
<code>CDRC;</code>	(Central call charge registration)

AMO-ZAND

`CHA-ZAND: LOADWARE, TM2L, 0;`

AMO-COT:

- For DTMF-Dial:

<code>ADD-COT: 10, IEVT &</code>	(Registration of implausible events)
--------------------------------------	--------------------------------------

NTON; (No Tone)

AMO-COP:

- For DTMF-Dial

ADD-COP: 21,	DTMF &	(Dual tone multiple frequency)
	DTM1 &	(Make/Break Ratio for DTMF 1)
	LSUP &	(Line supervision)
	RLSA &	(Backward Release after Release)
	NO1A &	(Outgoing digits not withheld)
	TIM1 &	(Supervision timer 1)
	NSDL;	(Line with no start dial signal)

AMO-PTIME

COPY-PTIME: 87, 16 ;

CHA-PTIME:

REST, 16, PARA, 16, 16, 0, 2, 0, P6, 0, 0, 0, 5, 32, 36, 17, P14;

P6=0	Without dial tone supervision
P6=1	With dial tone supervision
P14	See table in chapter 2.1

CHA-PTIME: REST, 16, LONG, 200, 10000, 100, 400, 400, 120, 5000;

CHA-PTIME: REST, 16, SHORT, 40, 90, 0, 0, 0, 0, 10, 0, 0, 2, 2, 0, 0, 36;

The meaning and the value for each parameter depends on the protocol used,

AMO TACSU

- Configuration for Trunk groups for DTMF

ADD-TACSU:	
<LAGE>	<ltg>-<ltu>-<slot>-2,
<NO>	,
<COTNO>	10,
<COPNO>	21,
<DPLN>	0,
<ITR>	0,
<COS>	10,
<LCOS>	1,
<LCOSD>	1,
<INIGHT>	,

<TGRP>	112,
<COFIDX>	0,
<CCT>	"DTMF",
<DESTNO>	0,
<ORDNO>	0,
<ALARMNO>	0,
<CARRIER>	,
<ZONE>	,
<INS>	YES,
<DEVTYP>	TC,
<DEV>	ANMOSIG,
<MFCVAR>	0,
<DGTRP>	*,
<SUPRESS>	0,
<DGCNT>	0,
<TESTNO>	1,
<CIRCIDX>	17,
<CDRINT>	1,
<CCTINFO>	0,
<DIALTYPE>	MOSIG-DTMF,
<DIALVAR>	0-0,
<COEX>	0,

AMO-LODR:

ADD-LODR:ODR=10,,,ECHO,2;
 ADD-LODR:ODR=10,,,END;

AMO-RICHT:

ADD-RICHT:MODE=LRTENEW, LRTE=03, LSVC=VCE, TGRP=112, DNNO=*,

* ## node number in AMO-ZAND

AMO-LDAT:

ADD-LDAT:LROUTE=03, LSVC=VCE, LVAL=1, TGRP=112, ODR=10, LAUTH=1;

AMO-LDPLN:

ADD-LDPLN:LDP=131-X, LROUTE=03, LAUTH=1;

For Pseudo-DID additional:**AMO-TACSU:**

```
CHA-TACSU:<ltg>-<ltu>-<slot>-
<satz>,DEVTYPE=TC,DIALTYPE=DTMF-DTMF,DIALVAR=4-0;
```

AMO-COP:

```
CHA-COP:20,COPADD,DTN;
```

AMO-COT:

```
CHA-
COT:10,COTADD,IBSY&IVAC&INAU&ITB&IFR&INDG&IIDL&DTNE [&DTNI];
```

AMO-FEASU:

```
CHA-FEASU:A,ICPTDID;
```

9.2.25 TM3WI/TM3WO

The trunk module 3 wires incoming/outgoing (TM3WI/TM3WO) are analog trunks. The TM3WI/TM3WO are 2 separate 4-channel interface cards providing connectivity between PBX and Central Office.



CAUTION: For lightning protection see [Section 2.3, "Lightning Protection"](#).

TM3WI interface card provides incoming whereas TM3WO provides outgoing signalling functions. Both cards provide circuits for the PCM encoding or decoding of the voice signals.

The TM3WI/TM3WO is designed to meet all applicable signalling, transmission, and product safety requirements for countries stated in TM3WI/TM3WO.

9.2.25.1 Board Variants

TM3WI: S30810-Q2477-X000

TM3WO: S30810-Q2476-X000

9.2.25.2 LED Indications

The front panel of the board contains one red and one green LED.

[Figure 98](#) shows a single channel circuit diagram of the TM3WI board.

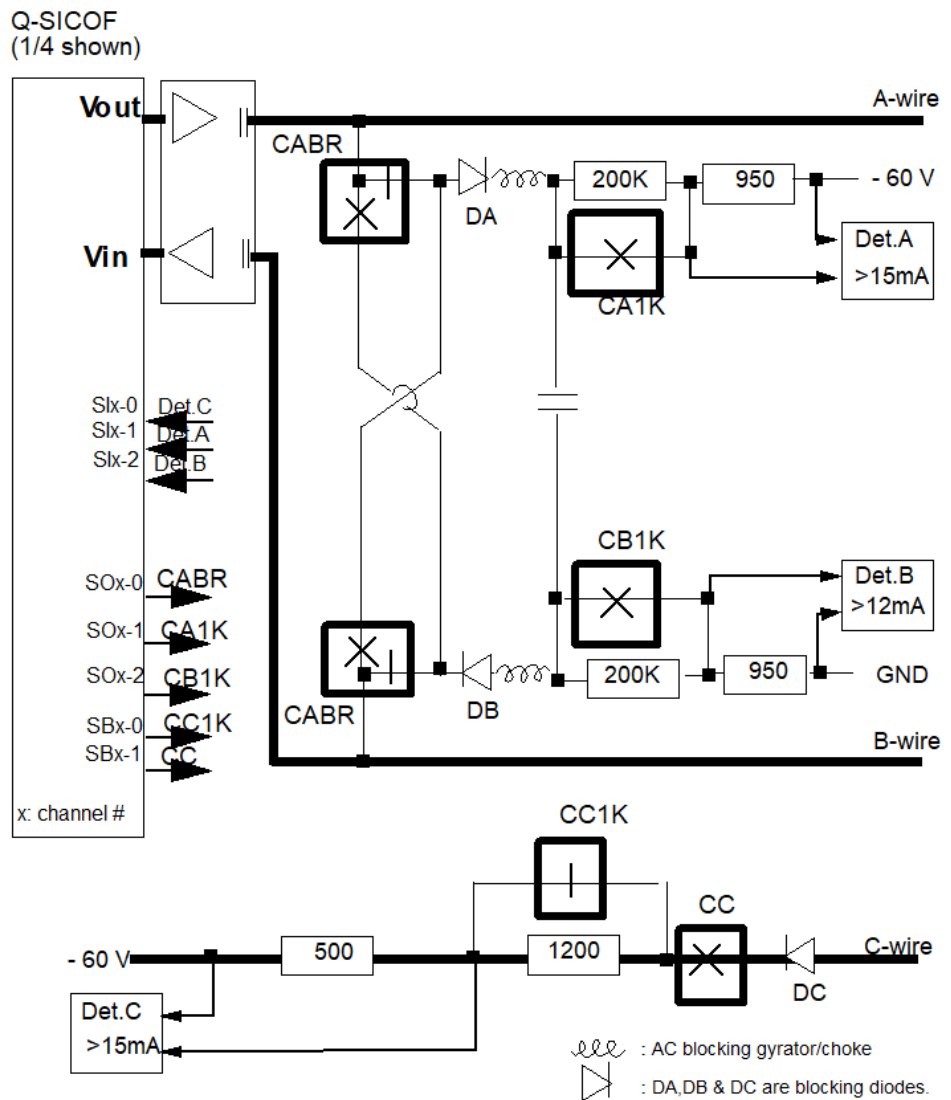

Figure 129: TM3WI Board Trunk interface Circuit Diagram (Single Channel Example)

CABR: Connect A & B wires with Reverse polarities.

CA1K: Connect A wire with 1K and Detector Det.B. **CB1K:** Connect B wire with 1K and Detector Det.A.

CC1K: Connect C wire with 1K. **CC:** Connect C wire.

The [Table 96](#) lists the edge-to-edge presentation between the CO and the line card on the three wires for any particular dc signaling protocol.

Table 109: Edge to Edge Electrical Presentation for Incoming Local Call

Release Control	Signal	Direct PBX-Co	A-Wire (PBX)	B-Wire (PBX)	C-Wire (PBX)	A-Wire (Co)	B-Wire (Co)	C-Wire (Co)	Voice Path
--	Idle	---	-1K	+1K	- (500-550)	isol (50-550)	isol	+(3K7-12K)	
--	Seizure	<---	-1K	+1K	- (500-550)	- (2K5-43K)	+1K	+(0-300)	=
--	Seizure Ack.	--->	-1K	+1K	-1700	- (2K5-43K)	+1K	+(0-300)	Dial Tone
--	Dialing	<---	-1K	+1K	-1700	+(0-500)/isol	(40-500)/isol	+(0-300)	=
--	Wait for answer	---	-1K	+1K	-1700	- (2K5-43K)	+1K	+(0-300)	Ring Back
--	Answer	--->	+1K	-200K	-1700	- (12K-43K)	+1K	+(0-300)	Speech
Bilateral	Clear Forward	<---	+1K	-200K	-1700	-1K	+(20-1K)	+(0-300)	=
Bilateral	Clear Backward (Busy B)	--->	+200K	-1K	-1700	-1K	+(20-1K)	+(0-300)	=
Bilateral	Release Forward	<---	+200K	-1K	-1700	isol	isol	+(3K7-12K)	
Bilateral	Release Guard	--->	-1K	+1K	- (500-550)	isol	isol	+(3K7-12K)	
Unilateral (A-On hook)	Release Forward	<---	X (p)	X(p)	-1700	isol	isol	+(3K7-12K)	
Unilateral	Release Guard	--->	-1K	+1K	- (500-550)	isol	isol	+(3K7-12K)	
Unilateral (B-On hook)	Clear Backward or busy (B) Congestion	--->	+200K	-1K	-1700	- (12K-43K)	+1K	+(0-300)	Busy
Unilateral (when A-On hook)	Release Forward	<---	+200K	-1K	-1700	isol	isol	+(3K7-12K)	

Legacy Hardware

Release Control	Signal	Direct PBX-Co	A-Wire (PBX)	B-Wire (PBX)	C-Wire (PBX)	A-Wire (Co)	B-Wire (Co)	C-Wire (Co)	Voice Path
Unilateral	Release Guard	--->	-1K	+1K	- (500-550)	isol	isol	+(3K7-12K)	12K
--	Blocking	--->	X(-1K)	X(+1K)	isol	isol	isol	+(3K7-12K)	12K

Explanation:

+xyK: Ground is presented along with xyK Ohms

xyK: -60V is presented along with xyK Ohms

X(xyK): Default is xyK

X(p): Kept at its previous state

isol: DC signalling path is open

==: Voice path is connected.

(C0): Connected to the Central Office or PBXI

For the relays the 0 indicates that the relay is not activated and the 1 indicates activation of the relay. For the current detectors the a 0 indicates NO DETECTION and a 1 indicates DETECTION. X(0) indicates "not relevant" but sets to 0 X(p) indicates "not relevant" but kept in its previous state p.

IMPORTANT: Detection.A for A wire; Detection B for B wire; Detection C for C wire unless otherwise stated.

Table 97 lists the signal sense and control presentation for an incoming local call.

Table 110: Signal Sense and Control for Incoming Local Call

Release control	Signal		DETECTOR STATUS			RELAY CONTROLS					Tone
			DET.A	DET.B	DET.C	CAB	CA1	CB1	CC1	CC	
--	Idle	---	0	0	0	0	1	1	0	1	
--	Seizure	in	0	0	1	0	1	1	0	1	
--	Seizure Ack.	out	0	0	1	0	1	1	1	1	Dial Tone
--	Dialing	in	P(1/0)	P(1/0)	1	0	1	1	1	1	
--	Wait for answer	---	0	0	1	0	1	1	1	1	Ring Back

Release control	Signal		DETECTOR STATUS			RELAY CONTROLS					Tone
			DET.A	DET.B	DET.C	CAB	CA1	CB1	CC1	CC2	
--	Answer	out	0 (DET.A for B wire)	0 (DET.B for A wire)	1	1	0	1	1	1	Speech
Bilateral	Clear Forward	in	0 (DET.A for B wire)	1 (DET.B for A wire)	1	1	0	1	1	1	Busy (from CO)
Bilateral	Clear Backward (Busy B)	out	1 (DET.A for B wire)	0 (DET.B for A wire)	1	1	1	0	1	1	Busy (present)
Bilateral	Release Forward	in	0 (DET.A for B wire)	0 (DET.B for A wire)	0	1	0	1	1	1	
Bilateral	Release Guard	out	0	0	0	0	1	1	0	1	
Unilateral (A-On hook)	Release Forward	in	0	0	0	0	X(p)	X(p)	1	1	
Unilateral	Release Guard	out	0	0	0	0	1	1	0	1	
Unilateral (B-On hook)	Clear Backward or busy (B) Congestion	out	1 (DET.A for B wire)	0 (DET.B for A wire)	1	1	1	0	1	1	Busy (present)
Unilateral (when A-On hook)	Release forward	in	0 (DET.A for B wire)	0 (DET.B for A wire)	0	1	1	0	1	1	
Unilateral	Release Guard	out	0	0	0	0	1	1	0	1	
--	Blocking (also the start up state before circuit is configured)	out	0	0	0	0	X(1)	X(1)	X(0)	0	

Legacy Hardware

Table 98 lists the edge-to-edge presentation for an incoming toll call.

Table 111: Edge to Edge Electrical Presentation for Incoming Toll Call

Release control	Signal	Direction PBX-Co	A-Wire (PBX)	B-Wire (PBX)	C-Wire (PBX)	A-Wire (Co)	B-Wire (Co)	C-Wire (Co)	Voice path
--	Idle	---	-1K	+1K	- (500-550)	isol	isol	+(3K7-12K)	
--	Seizure	<---	-1K	+1K	- (500-550)	- (15K-200K)	+(12K8-40K300)	+(0-300)=	
--	Seizure Ack.	--->	-1K	+1K	-1700	- (15K-200K)	+(12K8-40K300)	+(0-300)	Dial Tone
--	Dialing	<---	-1K	+1K	-1700	+(0-500)/isol	-(40-500)/iso,	+(0-300)=	
--	Extension Free (B Free)	--->	+1K	-1K	-1700	- (15K-200K)	+(12K8-40K300)	+(0-300)	Ring Back
--	Extension Busy (B Busy)	--->	+200K	-1K	-1700	-(12K8-200K)	+(12K8-40K300)	+(0-300)	Busy
--	Ring Trunk Signal (control ring cadence) Ring Request & Ring Removal	<---	+1K	-1K	-1700	- (12K8-45K)	+(0-60)	+(0-300)	Ring Back
						- (40-500)	+(12K8-40K300)	+(0-300)	
--	Answer	--->	+200K	-200K	-1700	- (15K-200K)	+(12K8-40K300)	+(0-300)	Speech
Unilateral (A-On hook)	Release Forward	<---	X(p))	X(p))	-1700	isol	isol	+(3K7-12K)	
Unilateral	Release Guard	--->	-1K	+1K	- (500-550)	isol	isol	+(3K7-12K)	
Unilateral (B-On hook)	Clear Backward or busy (B)	--->	+200K	-1K	-1700	-1K	+(20-1K)	+(0-300)=	

Release control	Signal	Directi PBX-- Co	A- Wire (PBX)	B- Wire (PBX)	C- Wire (PBX)	A-Wire (Co)	B- Wire (Co)	C- Wire (Co)	Voice path
Unilateral (when A-On hook	Release Forward	<---	+200K	-1K	-1700	isol	isol	+(3K7- 12K)	
Unilateral	Release Guard	--->	-1K	+1K	- (500- 550)	isol	isol	+(3K7- 12K)	
--	Blocking	--->	X(-1K)	X(+1K)	isol	isol	isol	+(3K7- 12K)	
--	Reset	<---	+200K	-1K	-1700	- (12K8-200K)	+(0-500)	(0-300)=	

Explanation:

+xyK: Ground is presented along with xyK Ohms

xyK: -60V is presented along with xyK Ohms

X(xyK): Default is set to xyK

X(p): Kept in its previous state

isol: Dc signaling path is open

==: Voice path is connected.

Reset has no impact on the PBX ring trunk signal,. It is ignored in the OpenScape 4000 due to automatic ringing.

Table 99 lists all criteria presented in the particular protocol. .X(0) indicates not relevant but set to 0X(p) indicates not relevant but kept to its previous state.

IMPORTANT: Detection.A for A wire; Detection B for B wire; Detection C for C wire unless otherwise stated.

Table 112: Signal Sense and Control for Incoming Toll Call

Release control	Signal		DETECTOR STATUS			RELAY CONTROLS					Tone
			DET.A	DET.B	DET.	CAB	CA1	CB1	CC1	CC	
--	Idle	---	0	0	0	0	1	1	0	1	
--	Seizure	in	0	0	1	0	1	1	0	1	
--	Seizure Ack.	out	0	0	1	0	1	1	1	1	Dial Tone
--	Dialing	in	P(1/0)	P(1/0)	1	0	1	1	1	1	

Legacy Hardware

Release control	Signal		DETECTOR STATUS			RELAY CONTROLS					Tone
			DET.A	DET.B	DET.	CAB	CA1	CB1	CC1	CC	
--	Extension Free (B Free)	out	0 (DET.A for B wire)	0 (DET.B for A wire)	1	1	1	1	1	1	Ring Back
--	Extension Busy (B Busy)	out	0 (DET.A for B wire)	0 (DET.B for A wire)	1	1	1	0	1	1	Busy
--	Ring Trunk Signal	in	1 (DET.A for B wire)	0 (DET.B for A wire)	1	1	1	1	1	1	Ring Back
			0 (DET.A for B wire)	1 (DET.B for A wire)							
--	Answer	out	0 (DET.A for B wire)	0 (DET.B for A wire)	1	1	0	0	1	1	Speech
Unilateral (A-On hook)	Release Forward	in	0	0	0	X(p)	X(p)	X(p)	1	1	
Unilateral	Release Guard	out	0	0	0	0	1	1	0	1	
Unilateral (B-On hook)	Clear Backward or busy (B)	out	1 (DET.A for B wire)	0 (DET.B for A wire)	1	1	1	0	1	1	Busy
Unilateral (A-On hook)	Release Forward	in	0 (DET.A for B wire)	0 (DET.B for A wire)	0	1	1	0	1	1	
Unilateral	Release Guard	out	0	0	0	0	1	1	0	1	
--	Blocking	out	X(0)	X(0)	X(0)	X(0)	1	1	X(0)	0	
--	Reset	in	1 (DET.A for B wire)	0 (DET.B for A wire)	1	1	1	0	1	1	

Figure 99 shows a circuit diagram of the TM3WO board.

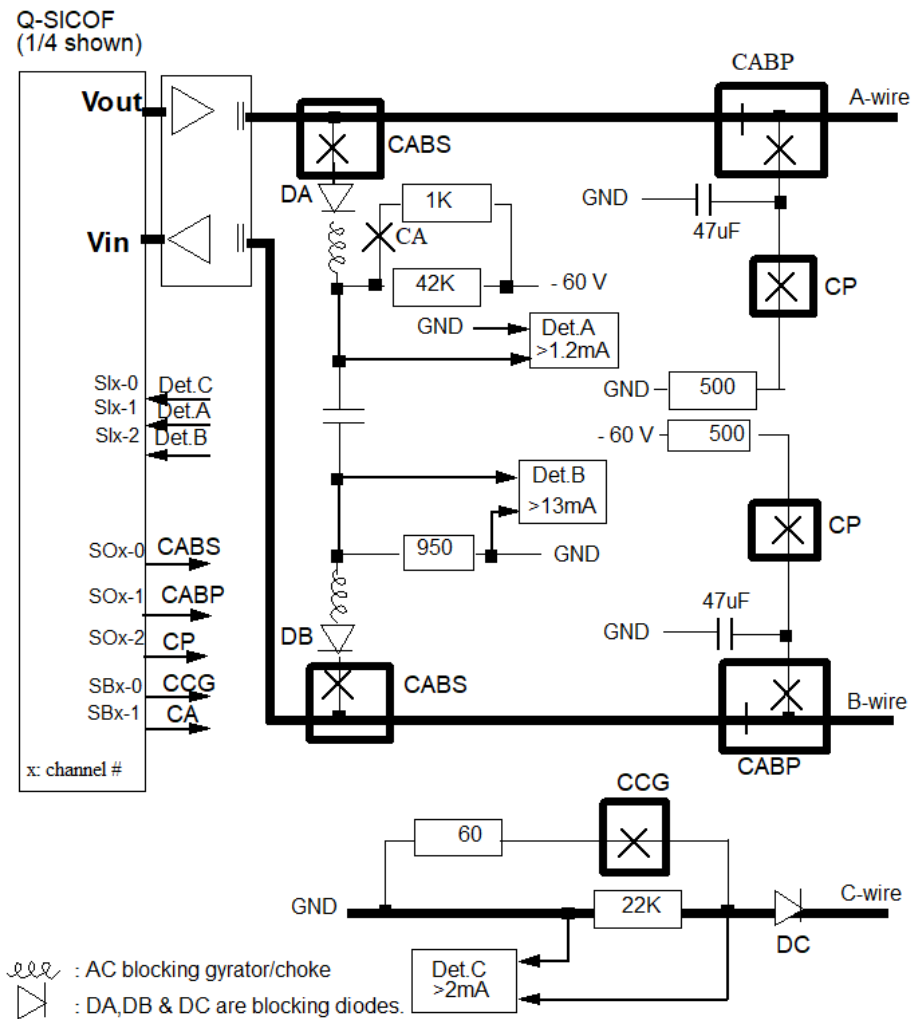

Figure 130: TM3WO Board Trunk interface Circuit Diagram (Single Channel Example)

CABS: Connect A & B wires for DC Signalling.

CABP: Connect A & B wires ready for dial Pulsing. CA: Connect A wire to 1K ohm.

CP: Dial pulsing A & B wires. CCG: Connect C wire to Ground.

Table 100 lists the edge-to-edge electrical presentation for an outgoing call.

Table 113: Edge to Edge Electrical Presentation for Outgoing Local Call

Release control	Signal	Direct PBX-- Co	A - Wire (PBX)	B - Wire (PBX)	C - Wire (PBX)	A- Wire (Co)	B- Wire (Co)	C- Wire (Co)	Voice path
--	Idle	---	isol	isol	+22K	isol	isol	- (550-300)	==

Legacy Hardware

Release control	Signal	Direct PBX-- Co	A - Wire (PBX)	B - Wire (PBX)	C - Wire (PBX)	A- Wire (Co)	B- Wire (Co)	C- Wire (Co)	Voice path
--	Seizure	--->	-42K	+1K	+60	isol	isol	- (550-1700)	== (300)
--	Seizure Ack. (or Ans removal)	<---	-42K	+1K	+60	-1K	+1K	- (1150-1700)	Dial tone
--	Dialing	--->	+(0-500)/ isol	(0-500)/ isol	+60	-1K	+1K	- (1150-1700)	##
--	Extension Busy (B Busy)	<---	-42K	+1K	+60	+200K	-1K	- (1150-1700)	Busy tone
--	Extension Free (B Free)	<---	-42K	+1K	+60	-1K	+1K	- (1150-1700)	Ring tone
--	Answer/ (ANI Reques +500Hz)	<---	-42K	+1K	+60	+1K	-200K	- (1150-1700)	Speech
Bilateral (A-On hook)	Clear Forward	--->	-1K	+1K	+60	+1K	-200K	- (1150-1700)	==
Bilateral	Clear Backward (When B Onhook)	<---	-1K	+1K	+60	+200K	-1K	- (1150-1700)	==
Bilateral	Release Forward	--->	isol	isol	+22K	+200K	-1K	- (1150-1700)	==
Bilateral	Release Guard	<---	isol	isol	+22K	isol	isol	- (550-1700)	== (300)
Unilateral (A-On hook)	Release Forward	--->	isol	isol	+22K	X	X	- (1150-1700)	==
Unilateral	Release Guard	<---	isol	isol	+22K	isol	isol	- (550-1700)	== (300)
Unilateral (B-On hook)	Clear Backward	<---	-42K	+1K	+60	+200K	-1K	- (1150-1700)	Busy tone

Release control	Signal	Direct PBX-- Co	A - Wire (PBX)	B - Wire (PBX)	C - Wire (PBX)	A- Wire (Co)	B- Wire (Co)	C- Wire (Co)	Voice path
Unilateral (A-On hook)	Release Forward	--->	isol	isol	+22K	+1K	-200K	- (1150-	== (1700)
Unilateral	Release Guard	<---	isol	isol	+22K	isol	isol	- (550-	== (300)
--	Blocking	<--	isol	isol	+22K	X	X	isol	==
--	False Signal	<---	-42k	+1K	+60	+1K	-1K	- (1150-	== (1700)

Explanation:

+xyK: Ground is presented along with xyK Ohms

xyK: -60V is presented along with xyK Ohms

X: Ignore

isol: Dc signalling path is open

==: Voice path is connected

##: Voice path is disconnected

(Co): Connection to Central Office or PBX also

To control relays, 0 indicates that the relay is not activated and 1 indicates activation of the relay. For the current detectors, 0 indicates NO DETECTION and 1 indicates DETECTION.

Table 114: Signal Sense and Control for Outgoing Local Call

Release control	Signal		DETECTOR STATUS			RELAY CONTROLS					Tone
			DET.	DET.	DET.	CAB	CAB	CP	CC	CA	
--	Idle	---	X(0)	X(0)	1	0	0	0	0	0	
--	Seizure	out	0	0	1	1	0	0	1	0	
--	Seizure Ack.	in	0	0	1	1	0	0	1	0	Dial Tone (optional)
--	Dialing	out	X(0)	X(0)	1	0	1	P(1/0)	0	0	
--	Extension Busy (B Busy)	in	0	1	1	1	0	0	1	0	Busy (speech path connected)

Legacy Hardware

Release control	Signal		DETECTOR STATUS			RELAY CONTROLS					Tone
			DET.	DET.	DET.	CAB	CAB	CP	CCC	CA	
--	Extension Free (B Free)	in	0	0	1	1	0	0	1	0	Ring Back (speech path connected)
--	Answer	in	1	0	1	1	0	0	1	0	Speech
Bilateral	Clear Forward	out	X	0	1	1	0	0	1	1	
Bilateral (B On hook)	Clear Backward	in	0	1	1	1	0	0	1	1	
Bilateral	Release Forward	out	X(0)	X(0)	1	0	0	0	0	0	
Bilateral	Release Guard	in	X(0)	X(0)	1	0	0	0	0	0	
Unilateral (A-On hook)	Release Forward	out	X(0)	X(0)	1	0	0	0	0	0	
Unilateral	Release Guard	in	X(0)	X(0)	1	0	0	0	0	0	
Unilateral (B-On hook)	Clear Backward or busy (B)	in	0	1	1	1	0	0	1	0	Busy (from CO)
Unilateral (A-On hook)	Release Forward	out	X(0)	X(0)	1	0	0	0	0	0	Busy
Unilateral	Release Guard	in	X(0)	X(0)	1	0	0	0	0	0	
--	Blocking	in	X(0)	X(0)	0	0	0	0	0	0	
--	False Signal	in	1	1	1	1	1	0	1	0	

9.2.25.3 Functions and Features for GUS

The TM3WI/TM3WO board has the following analog trunk interface functions:

- Three wires used for dc signalling and supervision.
- Programmable selection of signalling methods.
- Programmable transmit and receive gains

- Combined voice pair with dc signalling.- 2 wires.
- Optional 2-wire voice path is available for future target countries application.

The TM3WI/TM3WO has the following system features:

- Companding of the voice signal (Voice compression used in the PCM encoding/decoding to adapt non-linear characteristics in the Analog-Digital Conversion)
- Access to PCM highways with flexible time slot channel selection
- HDLC link to communicate with the PBXs switching unit.

9.2.25.4 Interfaces

There are three main functional boundaries to the TM3WI/TM3WO:

- Three wires DC signalling trunk interface
- Channel and voice-path interface
- Common control interface

9.2.25.5 Connector Pin Assignments

[Table 102](#) lists the pin assignments for the upper connector of the TM3WI/TM3WO board.

Table 115: TM3WI/TM3WO Board Upper Connector X1-X4

Pin #	Signal Name	Pin #	Signal Name	Pin #	Signal Name
41	NC	21	+5V	01	A-1
42	NC	22	GND	02	+12V
43	NC	23	B-1	03	A-2
44	NC	24	C-3	04	B-2
45	NC	25		05	A-3
46	NC	26	C-4	06	B-3
47	NC	27		07	A-4
48	NC	28	GND	08	B-4
49	NC	29	C-5	09	A-5
50	NC	30		10	B-5
51	NC	31	C-6	11	A-6
52	NC	32		12	B-6
53	NC	33	GND	13	A-7
54	NC	34	C-7	14	B-7

Pin #	Signal Name	Pin #	Signal Name	Pin #	Signal Name
55	NC	35		15	A-8
56	NC	36	-5V	16	B-8
57	NC	37	C-8	17	C-1
58	NC	38		18	
59	NC	39	GND	19	C-2
60	NC	40	+5V	20	

Table 103 lists the pin assignments for the lower connector of the TM3WI/TM3WO board.

Table 116: TM3WI/TM3WO Board Lower Connector X1-X4

Pin #	Signal Name	Pin #	Signal Name	Pin #	Signal Name
41	NC	21	+5V	01	RING
42	NC	22	GND	02	+12V
43	NC	23	GND	03	-48V
44	NC	24	DIAL1	04	-60V
45	TOUT*	25	DIAL2	05	+60V
46	FBPE	26	WGSYN	06	U-SLIC
47	TRST*	27	RGSYN	07	RCLK
48	TCK*	28	GND	08	RAC
49	TMS*	29	PRS	09	BA0
50	TDI*	30	BA1	10	RGCL
51	TDO*	31	HO1	11	RGD
52	HO3	32	HO0	12	BA6
53	HO2	33	GND	13	HD0
54	NC	34	BA2	14	BA5
55	NC	35	BA3	15	CKA
56	NC	36	-5V	16	CLS
57	HI3	37	FMB	17	HI1
58	HI2	38	HI0	18	BA4
59	NC	39	GND	19	HDI

Pin #	Signal Name	Pin #	Signal Name	Pin #	Signal Name
60	NC	40	+5V	20	-12V

Table 104 lists the pin assignments for the middle connector of the TE3WI/TM3WO board.

Table 117: TM3WI/TM3WO Board Middle Connector X3

Pin #	Signal Name
1	GND
2	+5VL

Table 105 lists some connectivity information about the TE3WI/TM3WO board.

Table 118: TM3WI/TM3WO Board MDF Connectivity Information

Part Number	HW ID Number	Country	Line Resistance	Operation Type	Number of total Channels	Number of Wires For Every Channel
TM3WI: Q2477-X000	EEFXH	Russia	2 x 1500 ohms	3 wires incoming (local & toll)	4	3
TM3WO: Q2476-X000	EEEXH	Russia	2 x 1500 ohms	3 wire outgoing (local)	4	3

Table 106 lists the wire designation for TM3WI/TM3WO board

Table 119: TM3WI/TM3WO Board OpenScape 4000 MDF A & B Wire Designation

Part Number	-----MDF -CABLE A/B Numbering-----															
	Set Number For Every Board															
	A & B & C wire designation								Not Used							
	1	3	5	7	9	11	13	15	2	4	6	8	10	12	14	16
TM3WI: Q2477-X000	1	1	2	2	3	3	4	4	5	5	6	6	7	7	8	8
	A_BC_	A_BC_	A_BC_	A_BC_	A_BC_	A_BC_	A_BC_	A_BC_	A_BC_	A_BC_	A_BC_	A_BC_	A_BC_	A_BC_	A_BC_	A_BC_
TM3WO: Q2476-X000	1	2	3	4	5	6	7	8	1	2	3	4	5	6	7	8
	A_BC_	A_BC_	A_BC_	A_BC_	A_BC_	A_BC_	A_BC_	A_BC_	A_BC_	A_BC_	A_BC_	A_BC_	A_BC_	A_BC_	A_BC_	A_BC_

9.2.25.6 Line Signaling Flow Diagrams

Figure 100 through Figure 109 shows line signaling diagrams. These diagrams show a dependency on the resistance (OTLOC).

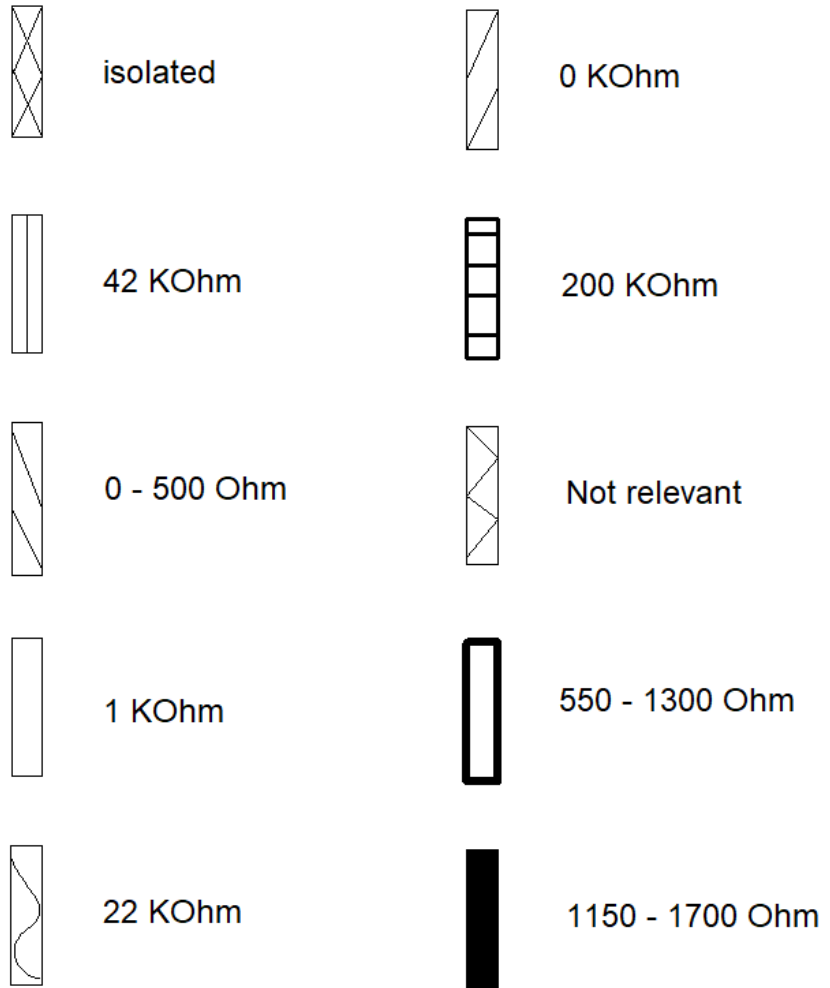

Figure 131: Symbols for the Resistance on A-, B- or C-Wire

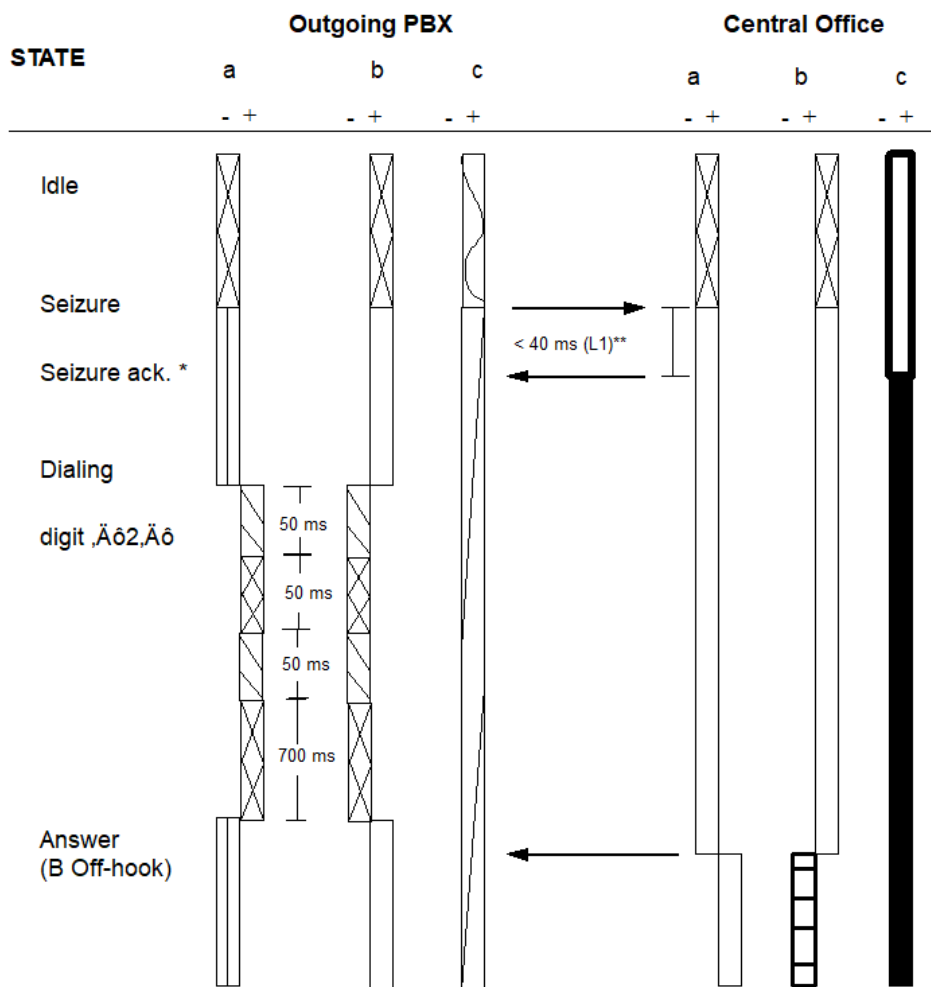

Figure 132: Seizure, Pulse Dial, B-Subscriber Free, Answer

* Due to the insignificant current changing, the seizure ack. line signal cannot be detected.

** L1: Long timer 1 (see PTIME)

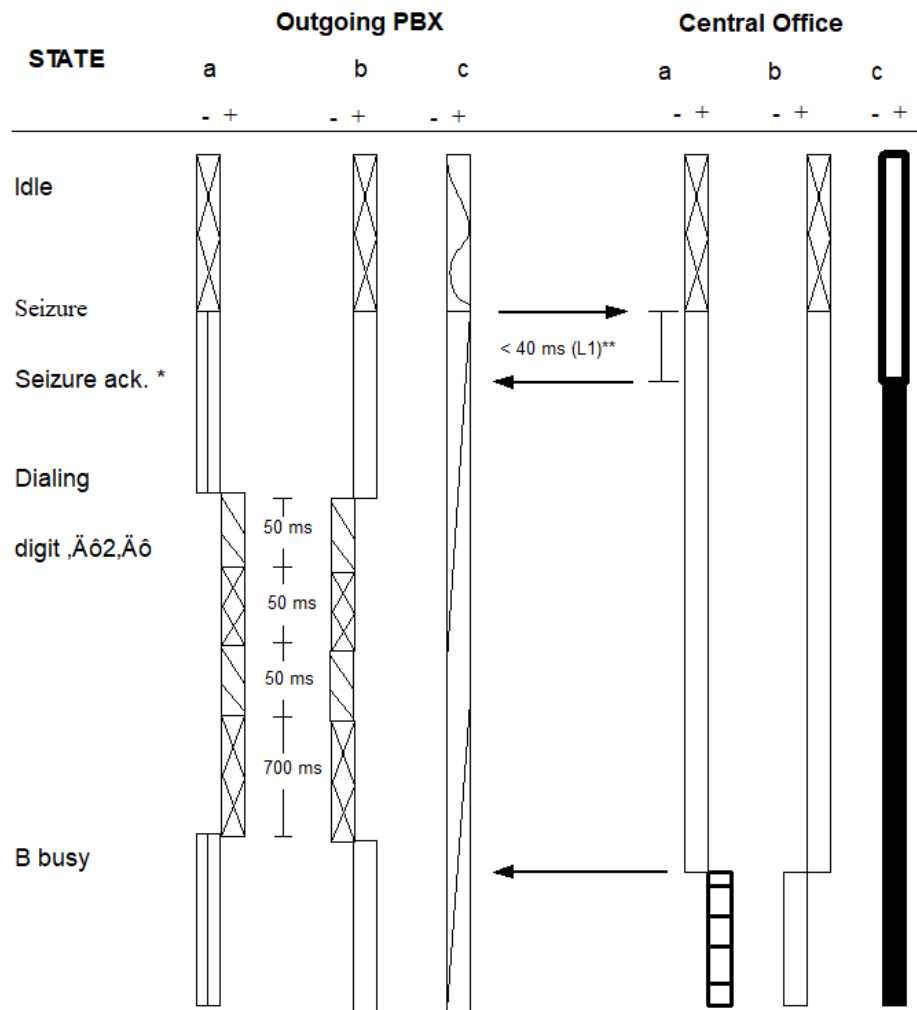
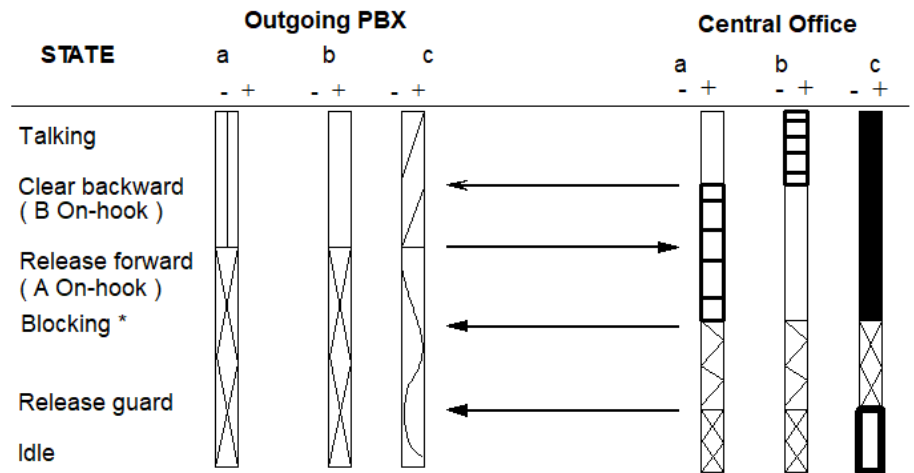

Figure 133: Seizure, Pulse Dial, B-Subscriber Busy

* Due to the insignificant current changing, the seizure ack.line signal can not be detected.

** L1: Long timer 1 (see PTIME)

9.2.25.7 First Party Release Control (MGTS)



* Optional, because some central offices do not send this signal

Figure 134: B goes On-Hook After Answer

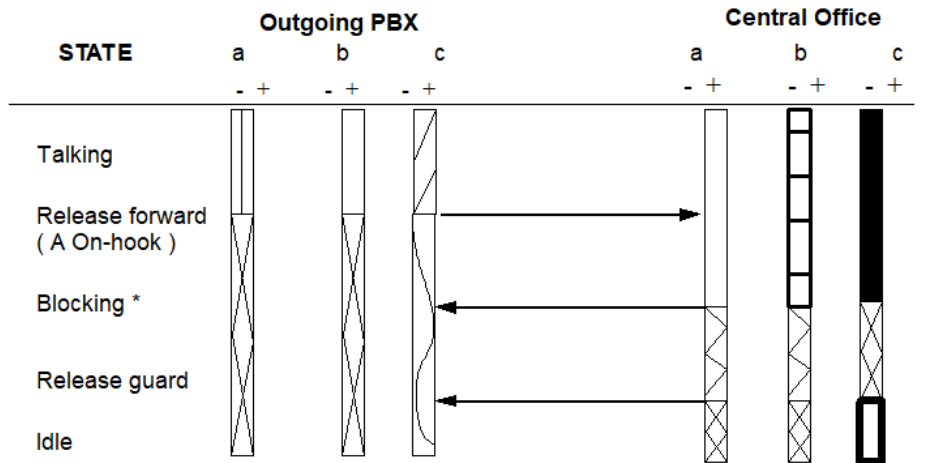

* Optional, because some central offices do not send this signal

Figure 135: A Goes On-Hook Before Dialing or Answering or After Answer

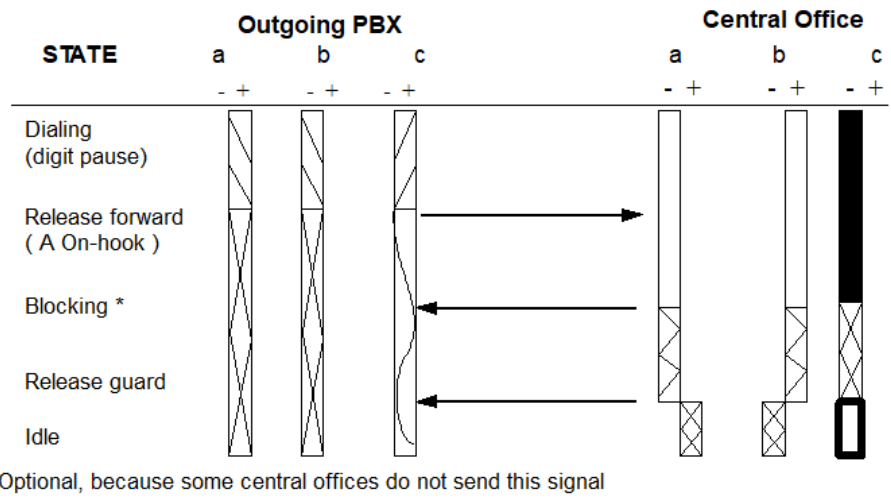

Figure 136: A Goes On-Hook During Digit Outputing

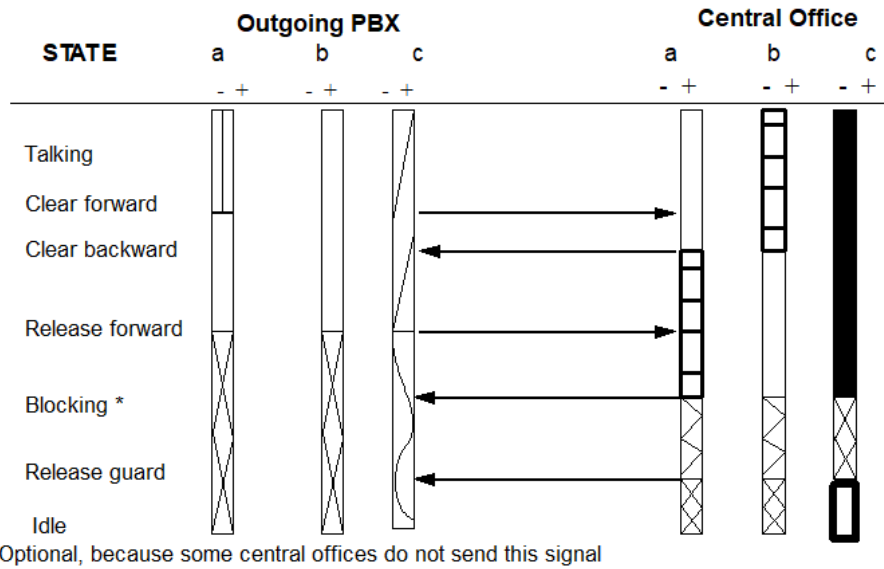
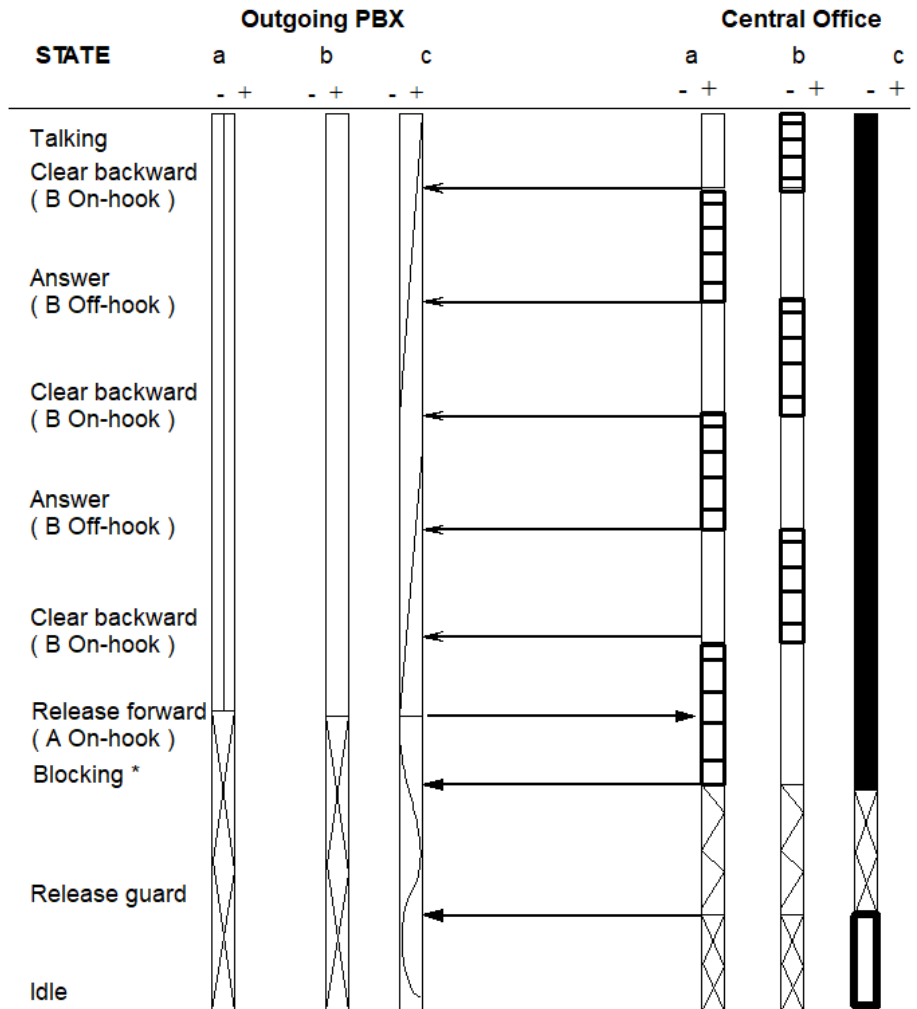

Figure 137: A Goes On-hook After Answer (P14 = 1)

9.2.25.8 Calling Party Release Control (Unilateral LONIIS)



* Optional, because some central offices do not send this signal

Figure 138: B goes On- or Off-hook After Answer

9.2.25.9 Calling party release control (Unilateral MGTS)

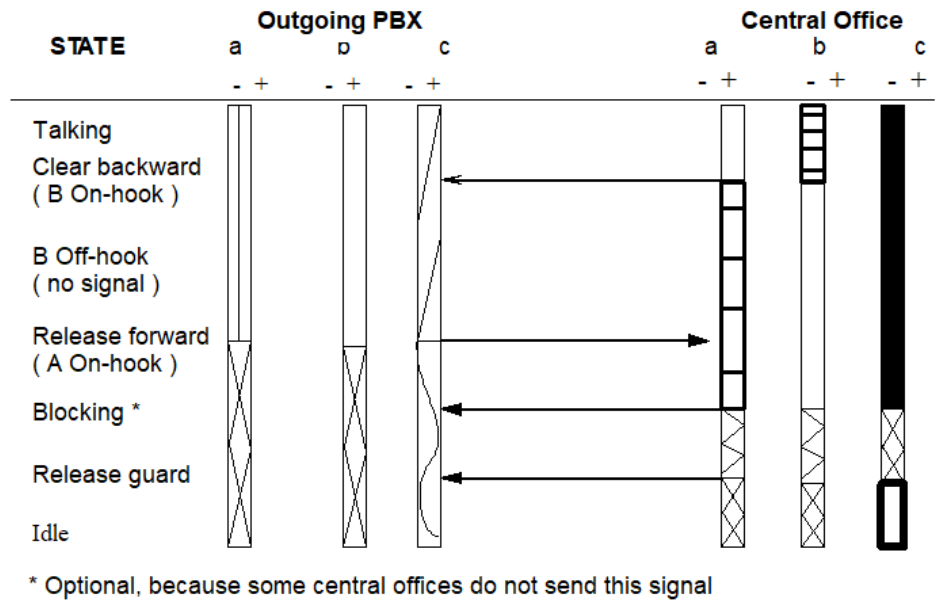

Figure 139: B goes on/off-hook after answer (MGTS)

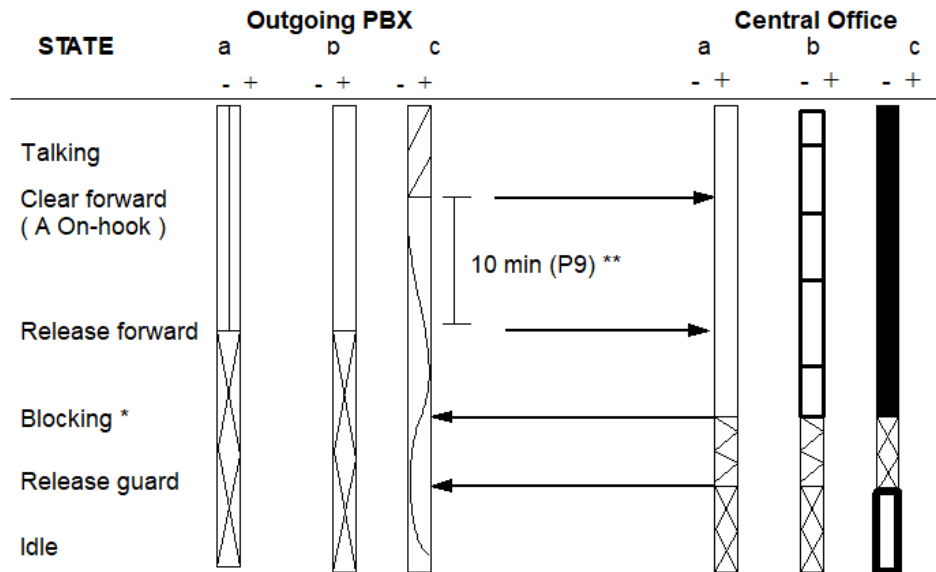

Figure 140: A goes On-Hook after Answer, B Remains Off-Hook

* Optional, because some central offices do not send this signal

** P9: Parameter 9 (see PTIME)

9.2.25.10 Signaling times for INLOC and OTLOC

Fixed and Administrative Timers:

- Incoming Local:

min.length of a qualified seizure	S1 = 20 ms
min. seizure ack. transmission time	300 ms
digit receiving :	
- min/max make time	20 ms/150 ms
- min/max break time	20 ms/150 ms
- interdigit time	>150 ms
min.length of a qualified clear forward (bilateral)	S2 = 70 ms
min.length of a qualified reseizure (bilateral)	20 ms
min.length of a qualified release forward:	20 ms
transmission time of blocking before release guard	150 ms

- Putting out of service and into service:

min. blocking signal transmission time	1200 ms
min.length of a qualified idle	150 ms

- Outgoing local:

seizure ack. simulation time	L1 = 40 ms
digit outpulsing:	
- make/break time	50/50 ms
- interdigit time	700 ms
min. length of a qualified ANI-Request	20 ms
min. length of a qualified ANI-Request to be interpreted as an answer	L5 = 2800 ms
min. length of a qualified answer without ANI-Request	L5 = 70 ms
min. length of a qualified answer removal	20 ms
min.length of a qualified answer removal to be interpreted as ANI-removal (P11 = 1 or 2)	L7 = 1300 ms
answer supervision time	P7 = 10 min
min. length of a qualified clear back	120 ms
min. length of a qualified reanswer signal	20 ms
min. length of a qualified B-busy signal	120 ms
min. length of a qualified release guard	S3 = 20 ms

delay time for forward release transmission	P9 = 10 min
time between clear forward and sending MCID-message to DH	P8 = 2 min
release guard supervision time (after release forward transmission)	L2 = 30s
outgoing guard time	P2 = 1 s

- Seizure for line test:

release forward transmission time	5 min
seizure transmission time	1 s

- Blocking outgoing:

min. length of a qualified blocking from the line	L4 = 1 s
min. length of a qualified idle after blocking	150 ms

- Putting into service:

idle transmission time	150 ms
min. length of a qualified idle for putting into service	150 ms

PTIME Parameter Overview

DEV = A3GUSLOC

Parameter:

P1:	dialing type (incoming)
	0 pulse dialing (default)
	1 DTMF
	2 MF dialing
P2:	blocking time - 1 sec unit (outgoing)
	1-250 default: 1 (= 1 sec.)
P3:	direction of seizure
	1 outgoing (default)
	2 incoming
P4:	false signal handling
	0 no action (outgoing and incoming) (default)
	1 system alarm with line testing (outgoing)
	2 system alarm without line testing (outgoing and incoming)

P5:	outgoing guard time - 1 sec. unit (outgoing)
	1 - 250 default: 1 (= 1sec)
P6:	dial tone detection (outgoing)
	0 no detection (default)
	1 dial tone has to be detected
P7:	answer supervision (outgoing)
	0 no supervision
	1-250 with supervision (30 sec. unit)
	default: 20 (= 10 min)
P8:	Malicious Call Identification after clear forward transmission (outgoing)
	0 no MCID (default)
	1-250 with MCID (30 sec. unit)
	recommended value: 4 (= 2 min)
P9:	delay time release forward transmission (outgoing)
	0 no delay
	1-250 with delay (30 sec. unit)
	default: 20 (= 10 min)
P10:	Clear forward receiving handling (incoming)
	0 send clear back line signal and release message to the system software (default)
	1 send "A On-hook" message to the system software
P11:	ANI-request (outgoing)
	0 ANI-request handling type 1 (no ANI-request process in the system software)
	1 ANI-request handling type 2 (inform the system software after detection the ANI-request signal in talk state by the trunk loadware)
	2 ANI-request handling type 3 (default) (inform the system software after detection the answer removal signal)

	by the trunk loadware)
	3 No ANI-request
P12:	manual busy override (incoming)
	0 no busy override (default)
	1 busy override
P13:	release guard missing handling (outgoing)
	0 no action
	1 system alarm with line testing
	2 system alarm without line testing(default)
P14:	release-variant (outgoing)
	0 LONIIS (default)
	output signal: release forward
	1 MGTS
	output signal: clear forward

Shorttimer:

S1:	min. length of a qualified seizure (incoming)
	10-255 ms
	default: 20 ms
S2:	reserve
S3:	min. length of a qualified release guard (outgoing)
	10-255 ms
	default: 20 ms

Longtimer:

L1:	seizure acknowledge simulation time (outgoing)
	4-30000 ms
	default: 40 ms
L2:	release guard supervision time (outgoing)
	1000-30000 ms
	default: 30000 ms
L3:	min. length of a qualified alarm

	1000-30000 ms
	default: 10000 ms
L4:	reserve
L5:	min. length of ANI-request as a qualified answer (outgoing)
	1000-30000 ms
	default: 2800 ms
L6:	speech channel through connection delay time (outgoing + P11 = 0 and incoming)
	1000-30000 ms
	default: 1000 ms
L7:	min. length of a qualified ANI-removal (only for outgoing and P11= 1or 2)
	1000-30000 ms
	default: 1300 ms

Signaling times

Fixed and administrative timers:

- Incoming traffic:

min. length of a qualified seizure	S1 = 20 ms
min. seizure ack.transmission time	300 ms
min. B-free transmission time	300 ms
min. B-busy transmission time	300 ms
transmission time of B-busy with override	1500 ms
min. answer transmission time	300 ms
min. length of a qualified release forward	20 ms
digit receiving:	
- min/max make timer	20 ms/150 ms
- min/max break timer	20 ms/150 ms
- interdigit time	> 150 ms
min. length of a qualified rering	150 ms
transmission time for blocking after release forward	150 ms
min. length of a qualified release forward after blocking	150 ms

min. length of a signal to be interpreted as false signal	L3 = 5 s
min. length of a qualified release forward after faults	150 ms

- Putting out of service and into service:

min. blocking transmission time	1200 ms
min.length of a qualified idle	150 ms

PTIME-parameter overview

DEV = A3GUSTOL

Parameter:

P1:	dialing type (incoming)
	0 pulse dialing (default)
	1 DTMF
	2 MF dialing
P2:	reserve
P3:	direction of seizure
	1 outgoing
	2 incoming(default)
P4:	false signal handling
	0 no action (outgoing and incoming) (default)
	1 system alarm with line testing (outgoing)
	2 system alarm without line testing (outgoing and incoming)
P5 to P10:	reserve
P11:	reserve
P12:	manual busy override (incoming)
	0 no busy override
	1 busy override (default)
P13:	reserve
P14:	reserve

Shorttimer:

S1:	min. length of a qualified seizure (incoming)
	10-255 ms

	default: 20 ms
S2:	reserve
S3:	reserve

Longtimer:

L1:	reserve
L2:	reserve
L3:	min. length of a qualified alarm 1000-30000 ms default: 10000 ms
L4:	reserve
L5:	reserve
L6:	speech channel through connection delay time (incoming) 1000-30000 ms default: 100 ms
L7:	reserve

9.2.26 TMBD

The trunk module Bundespost Deutschland (TMBD) trunk module has four circuits for every board. It can be used for signalling with main station interfaces (MOSIG) as well as DID with pulse signalling system. In any case, one-way and bothway operations with or without 16 kHz call charge registration is possible.



CAUTION: For lightning protection see [Section 2.3, "Lightning Protection"](#).

The operating mode is set using circuit data. The individual circuits on the board can be operated in different modes.

The front panel of the board has four LEDs and four disable keys (see [Figure 110](#)).

The TMBD board has three DIP-FIX switches for every circuit which allow setting of call data registration and line attenuation levels.

The board has a separate blocking key for each circuit.

IMPORTANT: When testing with the dial testing device, the board should be set to short-line, since feedback may occur with other settings.

Table 107 lists the DIP switches for call detail recording (CDR).

Table 120: TMBD DIP-FIX Switches for CDR

SET	DIP-FIX	Function	Variant	OFF1) long line	ON short line
0	SPU 1	Transmit level	A200	+ 22 dB	- 5 dB
1	SPU 2	16 kHz	X200	bis	bis
2	SPU 3		X300	- 5 dB	- 21 dB
3	SPU 4				
1) Delivered state					

Table 108 lists the DIP switches for line adaptation.

Table 121: TMBD, DIP-FIX Switches for Line Adaptation

SET	DIP-FIX	Function	Variant	OFF 1) long line	ON short line
0	SUR 1	Transmit	A200	- 0,5 dBr	- 4 dBr
1	2) SUR 2	digital - analog	X200	- 2 dBr	- 2 dBr
2	SUR 3		X300	- 0 dBr	
3	SUR 4				
0	SUT 1	Receive	A200	-6,5 dBr	- 3.0 dBr
1	2) SUT 2	analog - digital	X200	- 5,0 dBr	- 5.0 dBr
2	SUT 3		X300	- 7,0 dBr	
3	SUT 4				
1)	Delivered status				
2)	The DIP-FIX switches SUR and SUT are provided as a pair for each circuit. These have been replaced by fixed resistances for the A200 variant.				

Figure 110 shows a side view of the TMBD board.

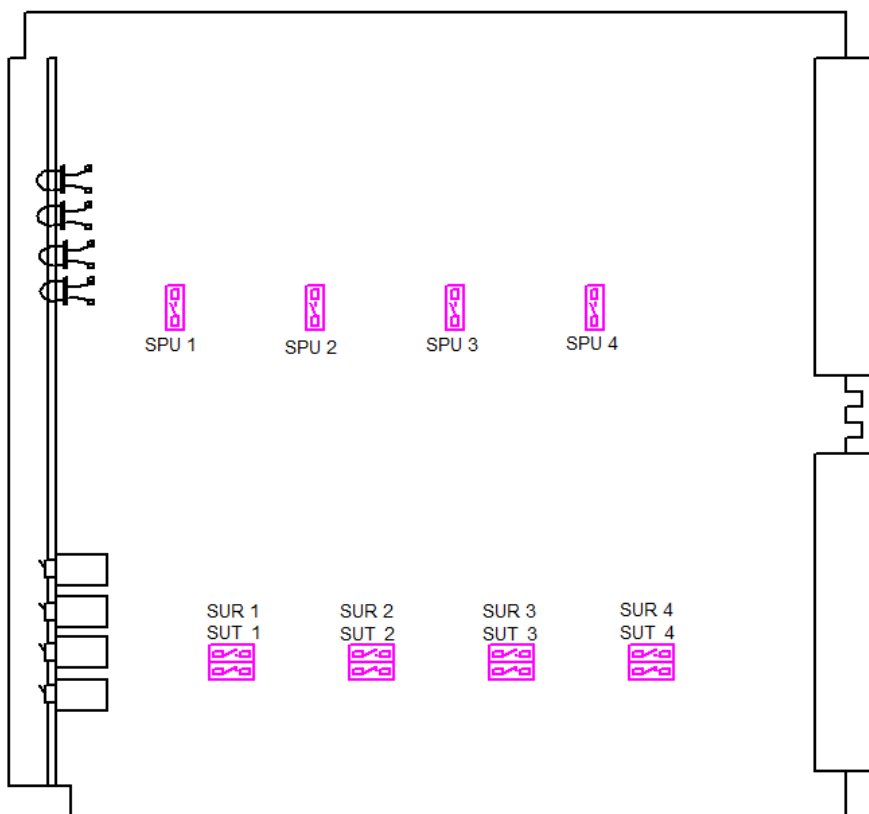

Figure 141: TMBD Board

9.2.27 TMC16

A16-channel central office trunk module (TMC16) board interfaces between central office trunks and the system by means of the LTUW and L80XF shelf backplane. It has 16 channels for connection to ground-start or loop-start trunks from the central office (CO). The TMC16 supports outbound calls and all incoming calls that are typically routed to the attendant console.



CAUTION: For lightning protection see [Section 2.3, "Lightning Protection"](#).

There are two versions of the TMC16 board. One version has SIVAPAC connectors and the other has a SIPAC connector. The SIVAPAC version (Model S30810-Q2475-X) requires SIVAPAC-to-SIPAC adapter or U.S. system migrations. The SIPAC version (Model S30810-Q2485-X) does not require any connector adapter and is available for new sales and system migrations in the U.S.

[Figure 111](#) shows a block diagram of a TMC16 board and the SWU.

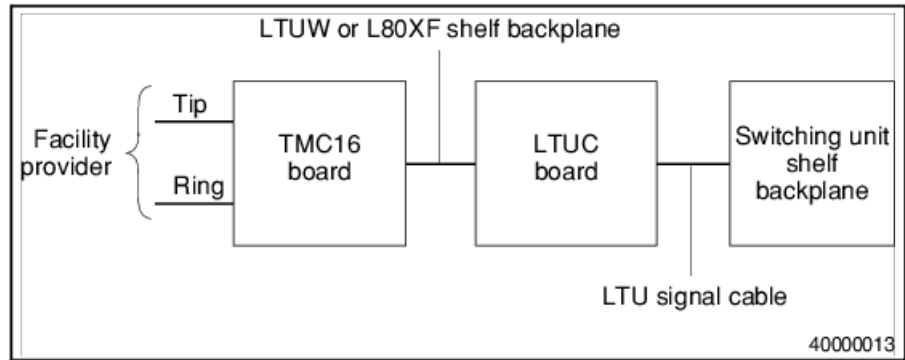

Figure 142: TMC16 Block Diagram

9.2.27.1 LED Indications

The front panel of the TMC16 board (Figure 112) contains two LEDs. Refer to Table 109 for LED indications of the TMC16 board

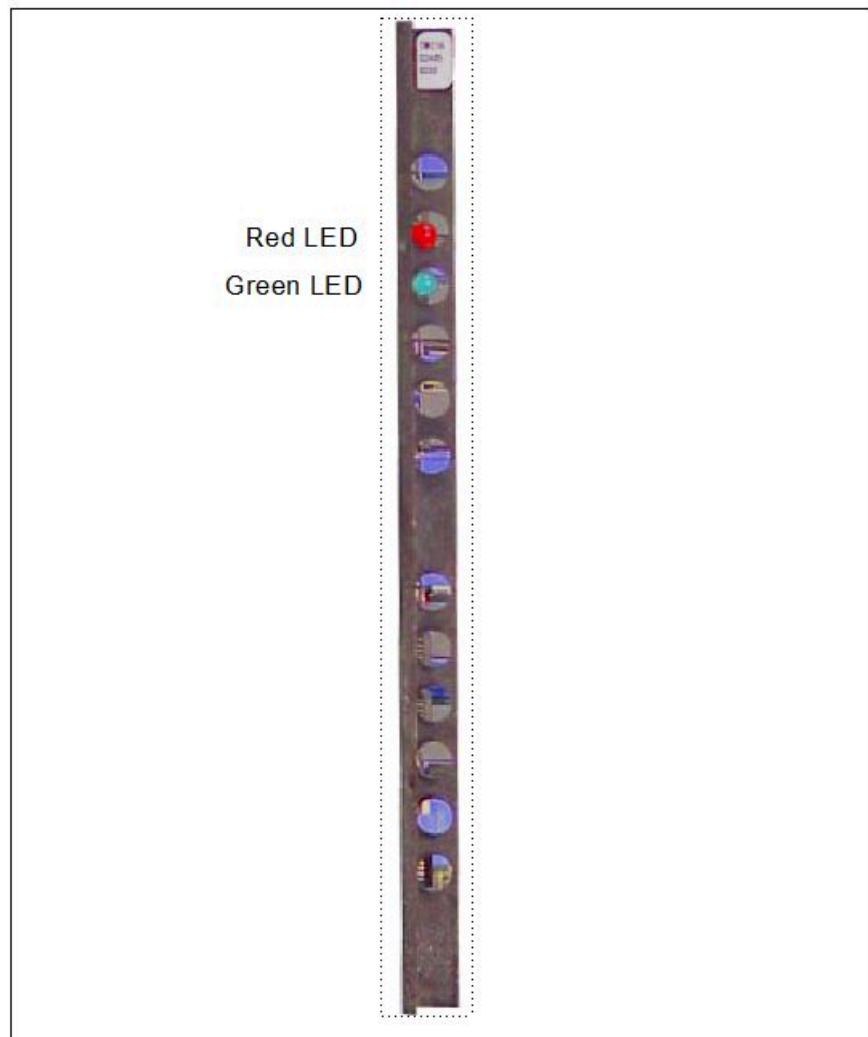

Figure 143: TMC16 Board Front Panel

Table 122: TMC16 Board LED Indications

Red LED	Green LED	Indication
On	Off	The board has initial power applied.
Flashing	Off	The board is being loaded with loadware.
On	Off	The board is defective or out-of-service
Off	On	The board is operational and all channels are on the on-hook state.
Off	Flashing	The board is operational and one or more channels are in the off-hook state.

9.2.27.2 Removing the TMC16 Board

IMPORTANT: This procedure removes all the channels on this trunk board from service.

NOTICE: Static Sensitive Devices! Observe all precautions for electrostatic discharge.

To remove the TMC16 board:

1) Deactivate all channels on the board as follows:

a) Type DEA-DSSU and press Enter.

b) Type the following values, then press Enter.

```
Field      Value
OFFTYPE   DC
TYPE      PEN
PEN1      <PEN1>
PEN2      <PEN2>
```

IMPORTANT: PEN1 is the PEN of the first channel, and PEN2 is the PEN of the last channel on the board.

2) Deactivate the board as follows:

a) Type DEA-BSSU and press Enter.

b) Type the following values, then press Enter.

```
Field      Value
OFFTYPE   DC
LTG        <1 - 32>
LTU        <1 - 8>
SLOT       <1 - 151>
REFOFF     <blank>
```

3) Wait for all LEDs to reach a fast flashing state (this indicates that the board is down).

4) Using the board extractor, unseat the board and remove it from the shelf.

9.2.27.3 Replacing the TMC16 Board

To replace the TMC16 board:

IMPORTANT: If you are replacing a TMCOT with a TMC16 or TMC16P board, change the hardware ID and the board type to TMC16 using CHANGE-BCSU.

- 1) Slide the board into the appropriate slot until it seats firmly into the backplane connector.
- 2) Activate the board as follows:
 - a) Type ACT-BSSU and press Enter.
 - b) Type the following values, then press Enter.

Field	Value
ONTYPE	AUL
LTG	<1 - 32>
LTU	<1 - 8>
SLOT	<1 - 151>

- 3) Activate the channels as follows:
 - a) Type ACT-DSSU and press Enter.
 - b) Type the following values, then press Enter.

Field	Value
ONTYPE	AUL
TYPE	PEN
PEN1	<PEN1>
PEN2	<PEN2>

IMPORTANT: PEN1 is the PEN of the first channel, and PEN2 is the PEN of the last channel on the board.

9.2.27.4 Verifying the TMC16 Board

To verify the operation of the TMC16 board, confirm that all LEDs have stopped flashing.

9.2.27.5 MDF Assignments

Table 110 shows the U.S. standard trunk board punch-down sequence. Each channel uses one tip and ring pair. Label the block from channel 00 through 15 or 23, as appropriate.

Table 123: TMC16 Board MDF Punch-Down Sequence

Pair No.	Wire Color	Channel No.	Pair No.	Wire Color	Channel No.
1	WHT-BLU BLU-WHT	00	14	BLK-BRN BRN-BLK	13

Pair No.	Wire Color	Channel No.	Pair No.	Wire Color	Channel No.
2	WHT-ORG ORG-WHT	01	15	BLK-SLT SLT-BLK	14
3	WHT-GRN GRN-WHT	02	16	YEL-BLU BLU-YEL	15
4	WHT-BRN BRN-WHT	03	17	YEL-ORG ORG-YEL	16
5	WHT-SLT SLT-WHT	04	18	YEL-GRN GRN-YEL	17
6	RED-BLU BLU-RED	05	19	YEL-BRN BRN-YEL	18
7	RED-ORG ORG-RED	06	20	YEL-SLT SLT-YEL	19
8	RED-GRN GRN-RED	07	21	VIO-BLU BLU-VIO	20
9	RED-BRN BRN-RED	08	22	VIO-ORG ORG-VIO	21
10	RED-SLT SLT-RED	09	23	VIO-GRN GRN-VIO	22
11	BLK-BLU BLU-BLK	10	24	VIO-BRN BRN-VIO	23
12	BLK-ORG ORG-BLK	11	25	VIO-SLT SLT-VIO	Not used.
13	BLK-GRN GRN-BLK	12			

9.2.28 TMCOW

The trunk module central office world (TMCOW) board is a two-wire interface to analog public network exchanges (central office) with loop signaling for

- Outgoing traffic with pulse dialing or DTMF dialing
- Incoming traffic to the attendant console



CAUTION: For lightning protection see [Section 2.3, "Lightning Protection"](#).

The board consists of eight circuits. It replaces the TMLRW, TMLRS, TMEDG and TMELS boards.

- Line signaling
 - Impedance in idle state
 - Ring detection (16 2/3 Hz, 20 ... 50 Hz)
 - Seizure / answering by means of loop closure
 - Pulse signaling or DTMF signaling by means of SIU
 - Ground to a-wire or ground to b-wire
 - Exchange polarity reversal detection
 - Call charge pulse detection (50 Hz, 12 kHz, 16 kHz)
- Signaling systems
 - MOSIG
 - Loop-Start
 - Ground-Start

Figure 113 shows the side view of the TMCOW board.

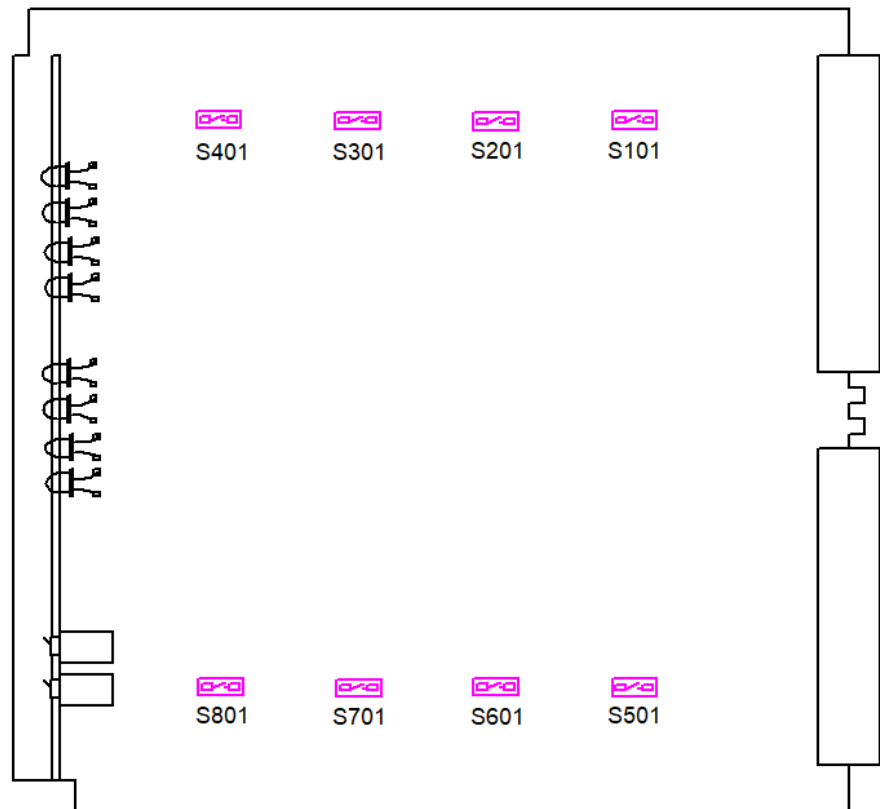

Figure 144: TMCOW Board

9.2.28.1 Module Variants

Table 111 lists the variants of the TMCOW board.

Table 124: TMCOW Board Variants

Variant Q2288-	Country
X	L

Variant Q2288-	Country
X10	B
X20	B
X30	RSA
X40	PRC (ASEAN)
X50	SF
X110	I
X120	H, IRL
X300	MEX
X310	BRA

9.2.28.2 LED Indications

The front panel of the board contains eight LEDs and two keys (see [Figure 113](#)).

The busy status of each circuit is indicated by a separate LED. The first key selects the circuit. The second key locks the circuit

9.2.28.3 DIP-FIX Switches

The DIP switches allows five different loop resistances to be set on the TMCOW board, depending on the line resistance (RL). The values shown in [Table 112](#) are calculated on the basis of 20 mA direct current with a battery voltage of 45 V and 2 x 400 Ohms impedance in the exchange.

Table 125: TMCOW Board DIP Switch Settings for Line Adaptation

Switches			2 x RL	RDC
1	2	3		
OFF	OFF	OFF	2 x 530 Ω	380 Ω
ON	OFF	OFF	2 x 430 Ω	590 Ω
OFF	ON	OFF	2 x 385 Ω	680 Ω
OFF	OFF	ON	2 x 280 Ω	890 Ω
ON	OFF	ON	2 x 185 Ω	1080 Ω

9.2.28.4 Call Charge Pulse Detection at 50 Hz

Table 113 lists the three different receiver sensitivity values that can be set for 50-Hz call charge pulses.

Table 126: TMCOW board, Receiver Sensitivity Levels

Switches			Receiver
4	5	6	Sensitivity
ON	OFF	OFF	30 V rms
OFF	ON	OFF	45 V rms
OFF	OFF	ON	66 V rms

9.2.28.5 Loop Grounding

To set loop grounding, set the DIP switches as follows:

- Switch 7 ON: a-wire grounded with 27 Ω
- Switch 8 ON: b-wire grounded with 360 Ω

Table 114 lists the DIP switch settings for the TMCOW board.

Table 127: TMCOW board, DIP -FIX switches 7 and 8

Switches		Countries
7	8	
OFF	ON	China, United Kingdom
ON	OFF	Rest of world
Never set both switches to ON!		

9.2.28.6 Loadware Variants

Table 115 lists the loadware variants for the TMCOW board.

Table 128: TMCOW Board Loadware Variants

Country	Input	Artificial Line	Line Loss	Line
BEL	150+(830//72nF)	150+(830//72nF)	-4/-3	short
BEL	150+(830//72nF)	150+(830//72nF)	-6/-1	long
PRC	600 Ω	600 Ω	-3/-4	
PRC	600 Ω	600 Ω	-4/-3	

Country	Input	Artificial Line	Line Loss	Line
PRC	200+(680//100nF)	600 Ω	-3/-4	
PRC	200+(680//100nF)	100+(820//68nF)	-4/-3	
PRC	600 Ω	100+(820//68nF)	-4/-3	
PRC	200+(680//100nF)	100+(820//68nF)	-3/-4	
GB	370+(620//310nF)	300+(1000//220nF)	-8/-2	
ITL	600 Ω	400+(700//200nF)	-5/-2	
ITL	600 Ω	400+(700//200nF)	-6/-1	
ITL	600 Ω	400+(700//200nF)	0/-7	
LUX	220+(820//115nF)	220+(820//115nF)	-5/-2	short
LUX	220+(820//115nF)	220+(820//115nF)	-7/0	long
RSA	220+(820//115nF)	220+(820//115nF)	-5/0	

Table 116 lists the line attenuation values for the TMCOW board.

Table 129: TMCOW, Line Attenuation Values

Cable wire gauge (mm)	Line impedance (Ω/km)	Line loss (dB/km)	Line length at	
			2 dB (km)	3 dB (km)
0.6	2 x 62.5	1	2	3
0.4	2 x 135	1.8	1.1	1.7

Table 117 lists the countries of application for the TMCOW and reference boards.

Table 130: TMCOW, Countries of Application and Reference Boards

Country	TMCOW					Reference Board			
	HW Variant	LW Variant	Call charge pulse	Line length	COF Index	Name	HW Ref. No.	LW Variant	COF Index
ARG	X200	1	50 Hz		0	TMLRW	Q2088-X200	TLRW00	0
BEL	X10	3	16 kHz	long	0	TMLRW	Q2088-X1	TLRW01	0
	X20	3	16 kHz	short	1	TMLRW	Q2088-X1	TLRW00	0

Country	TMCOW					Reference Board			
	HW Variant Q2288	LW Variant PZGTCOV	Call charge pulse	Line length	COF Index	Name	HW Ref. No.	LW Variant PZG..	COF Index
PRC	X40	C	16 kHz			TMGSR, TMELS	Q2075-X101 Q2272-X	TMGS TEDG	0...5 10...5
FIN	X50	8	16 kHz			TMLRW	Q2088-X3	TLRW	0
GB	X230	7	50 Hz	long	0	TMEDG	Q2172-X200	0	0 / 1
ITL	X110	D	12 kHz	l/m/s	0/1/2	TMLRW	Q2088-X101	TLRW	20/-/1
LUX	X	L	16 kHz	long/short	0/1	TMLRW	Q2088-X	TLRW	15 / 4
MLD						TMGSR	Q2075-X101	TMGS	6 / 7
MEX	X300	G	none		0	TMLRW	Q2088-X200	TLRW	0
RSA	X30	6	16 kHz		0	TMLRW	Q2088-X300	TLRW	13

l/m/s = long/medium/short

Table 118 lists the TMCOW hardware compatibility to narrowband and broadband switches.

Table 131: TMCOW Board Hardware Compatibility

TMCOW HW Version	TRIC (23-80 Hz) PTIME P9=1	Narrowband Switch (13-33Hz) PTIME P9=0	Broadband Switch (13-80Hz) PTIME P9=2
S30810-Q2288-X	up to -Q2288-X-7		ab S30810-Q2288-X-8
S30810-Q2288-X10	up to -Q2288-X10-4		ab S30810-Q2288-X10-5
S30810-Q2288-X20	up to -Q2288-X20-4		ab S30810-Q2288-X20-5
S30810-Q2288-X40	up to -Q2288-X40-5		ab S30810-Q2288-X40-6

TMCOW HW Version	TRIC (23-80 Hz) PTIME P9=1	Narrowband Switch (13-33Hz) PTIME P9=0	Broadband Switch (13-80Hz) PTIME P9=2
S30810-Q2288-X50		up to -Q2288-X50-3	ab S30810-Q2288-X50-4
S30810-Q2288-X60			ab S30810-Q2288-X60-1
S30810-Q2288-X100			ab S30810-Q2288-X100-1
S30810-Q2288-X120		up to -Q2288-X120-2	ab S30810-Q2288-X120-3
S30810-Q2288-X130			ab S30810-Q2288-X130-1

9.2.29 TMDID

The trunk module direct inward dialing (TMDID) board provides eight channels to an interface to the public switching network. It supports incoming calls only and permits these calls to directly reach the target extension without the assistance of an operator. The calls are routed to the SWU through the LTUW or L80XF shelf backplane and LTU signal cable.



CAUTION: For lightning protection see [Section 2.3, "Lightning Protection"](#).

IMPORTANT: Outbound calls cannot be routed over TMDID trunks.

Figure 114 shows an interface diagram of a TMDID board.

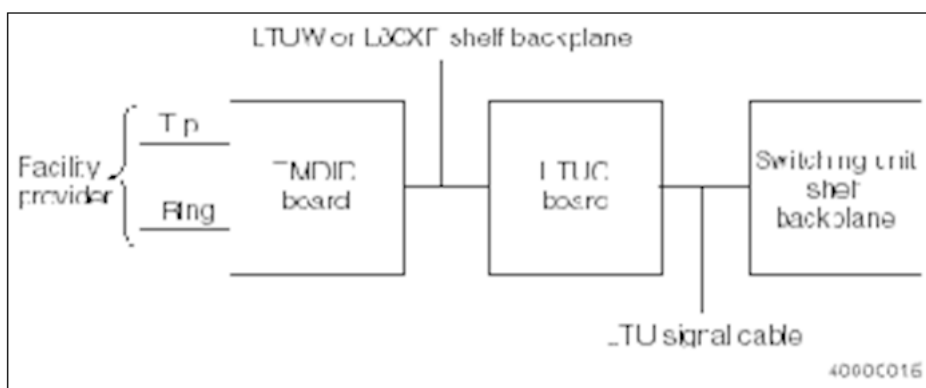

Figure 145: TMDID Board Block Diagram

9.2.29.1 LED Indications

The front panel of the TMDID board (Figure 115) contains eight channel and blocking status LEDs. Table 119 lists the LED indications for the TMDID board.

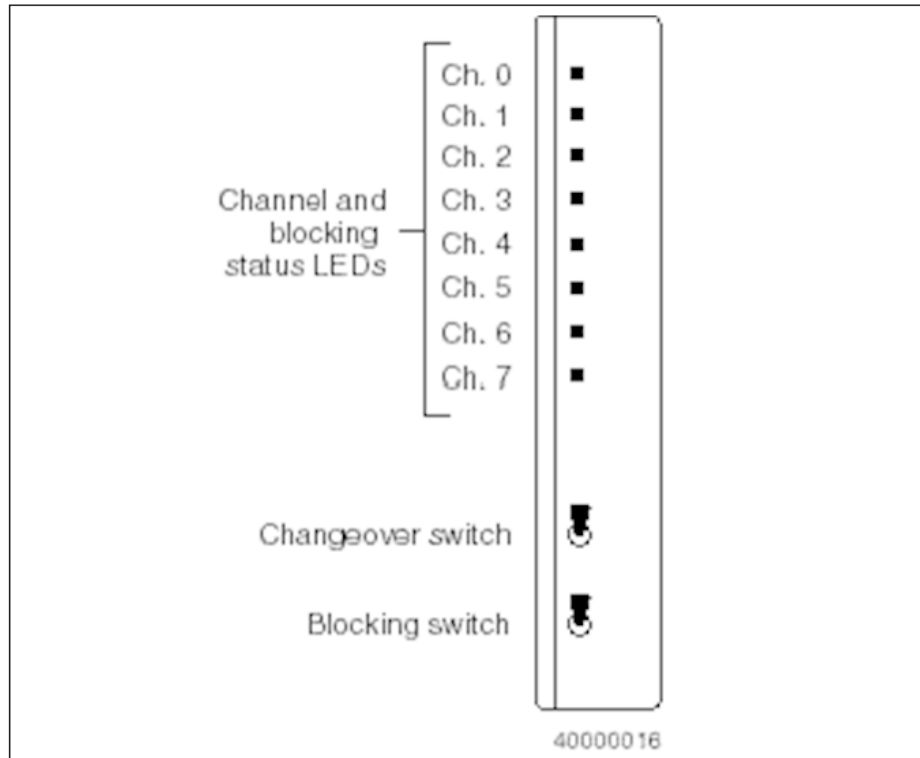

Figure 146: TMDID Board Front Panel

Table 132: TMDID Board LED Indications

LED	State	Indication
All (green)	Off	The channel is idle, ready to use.
	On	The channel is seized by call processing software.
	Slow flash	The channel is deactivated by software.
	Rapid flash	The upper toggle switch is pressed down and the channel is selected for manual activation or deactivation.

9.2.29.2 Switches

The TMDID board provides switches for manually selecting and blocking channels. The TMDID board (Figure 115) contains the following switches:

- A front panel changeover switch for manually selecting a channel by cycling through the channels until the status LED for the desired channel flashes
- A front panel blocking switch for manually blocking the selected channel

9.2.29.3 Removing the TMDID Board

IMPORTANT: This procedure will remove all the channels on this trunk board from service.

NOTICE: Static Sensitive Devices! Observe all precautions for electrostatic discharge.

Remove the TMDID board as follows:

1) Deactivate all channels on the board as follows:

- a) Type DEA-DSSU and press Enter.
- b) Type the following values, then press Enter.

Field	Value
OFFTYPE	DC
TYPE	PEN
PEN1	<PEN1>
PEN2	<PEN2>

IMPORTANT: PEN1 is the PEN of the first channel and PEN2 is the PEN of the last channel on the board.

2) Deactivate the board as follows:

- a) Type DEA-BSSU and press Enter.
- b) Type the following values, then press Enter.

Field	Value
OFFTYPE	DC
LTG	<1 - 32>
LTU	<1 - 8>
SLOT	<1 - 151>
REFOFF	<blank>

- 3) Wait until all LEDs on the board are flashing.
- 4) Using the board extractor, unseat the board and remove it from the shelf.

9.2.29.4 Replacing the TMDID Board

Replace the TMDID board as follows:

1) Slide the board into the appropriate slot until you seat it firmly into the backplane connector.

2) Activate the board as follows:

- a) Type ACT-BSSU and press Enter.
- b) Type the following values, then press Enter.

Field	Value
ONTYPE	AUL
LTG	<1 - 32>
LTU	<1 - 8>
SLOT	<1 - 151>

3) Activate the channels as follows:

- a) Type ACT-DSSU and press Enter.
- b) Type the following values, then press Enter.

Field	Value
ONTYPE	AUL
TYPE	PEN
PEN1	<PEN1>
PEN2	<PEN2>

IMPORTANT: PEN1 is the PEN of the first channel and PEN2 is the PEN of the last channel on the board.

9.2.29.5 Verifying the TMDID Board

Verify operation of the TMDID board by displaying the status of all channels as follows:

- 1) Type DIS-SDSU and press Enter.
- 2) Type the following values, then press Enter.

Field	Value
LINK	<blank>
LTG	<1 - 32>
LTU	<1 - 8>
SLOT	<1 - 151>
CCT	<blank>

9.2.29.6 MDF Assignments

In the U.S., cable punch-down is standard (refer to [Table 120](#)). Each channel uses one tip and ring pair. Label the block from 00 through 07.

Table 133: Standard Punch-Down Sequence

Pair No.	Wire Color	Channel No.	Pair No.	Wire Color	Channel No.
1	WHT-BLU BLU-WHT	00	14	BLK-BRN BRN-BLK	13
2	WHT-ORG ORG-WHT	01	15	BLK-SLT SLT-BLK	14
3	WHT-GRN GRN-WHT	02	16	YEL-BLU BLU-YEL	15
4	WHT-BRN BRN-WHT	03	17	YEL-ORG ORG-YEL	16
5	WHT-SLT SLT-WHT	04	18	YEL-GRN GRN-YEL	17

Pair No.	Wire Color	Channel No.	Pair No.	Wire Color	Channel No.
6	RED-BLU BLU-RED	05	19	YEL-BRN BRN-YEL	18
7	RED-ORG ORG-RED	06	20	YEL-SLT SLT-YEL	19
8	RED-GRN GRN-RED	07	21	VIO-BLU BLU-VIO	20
9	RED-BRN BRN-RED	08	22	VIO-ORG ORG-VIO	21
10	RED-SLT SLT-RED	09	23	VIO-GRN GRN-VIO	22
11	BLK-BLU BLU-BLK	10	24	VIO-BRN BRN-VIO	23
12	BLK-ORG ORG-BLK	11	25	VIO-SLT SLT-VIO	Not used.
13	BLK-GRN GRN-BLK	12			

9.2.30 TMDID2

IMPORTANT: For selected countries only!

The TMDID2 board (**T**run**k M**odule **D**irect **I**nward **D**ialing) provides direct inward dialing from the central office (CO) to OpenScape 4000. It supports incoming calls only and permits these calls to directly reach the target extension without the assistance of an operator.



CAUTION: For lightning protection see [Section 2.3, "Lightning Protection"](#).

IMPORTANT: Outbound calls cannot be routed over TMDID trunks.

The board has eight trunk circuits that connect to analog trunks. The board supports the protocols Wink Start, Delay Dial, and Immediate Start.

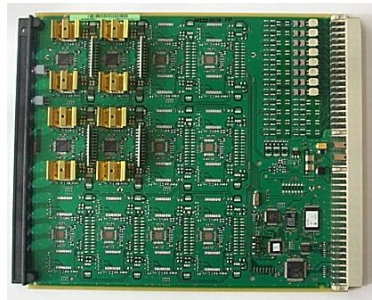

Figure 147: TMDID2 Board Type

9.2.30.1 Front Panel

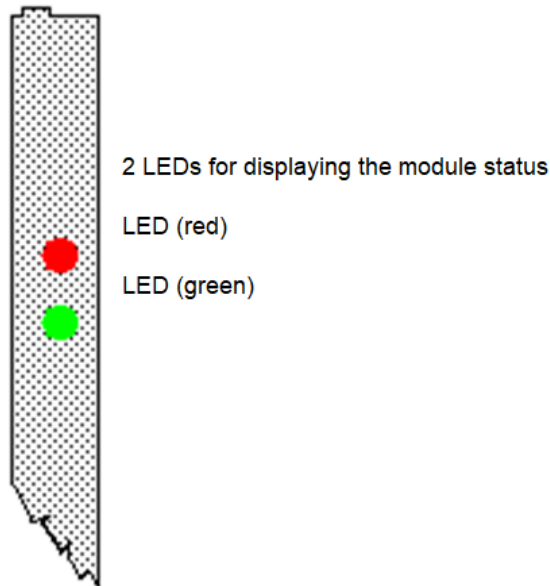

Figure 148: TMDID2 - Front Panel

IMPORTANT: To ensure sufficient shielding, provide the board with a shielding panel.

9.2.30.2 LED Statuses and Their Meanings

Table 134: LED Statuses and Their Meanings

Red LED	Green LED	Status	Action
Off	Off	Board not receiving power or not plugged in correctly. Board is out of order.	Check plug contact on board.

Red LED	Green LED	Status	Action
On	Off	Board is receiving power and board test is in progress. Board is defective if status remains unchanged (board test unsuccessful).	Replace board.
		Loadware loading not successfully completed. Board is faulty.	Replace board.
		Error detected on board. Board is deactivated (not applicable to errors detected by test loops) or board was deactivated using OpenScape 4000 Manager.	Check whether the board was deactivated using OpenScape 4000 Manager. If not, replace board.
Flashing	Off	Loadware is being loaded.	
Off	On	Board test completed successfully. Board is OK (idle state).	
Off	Flashing	At least one subscriber line circuit is activated.	

9.2.30.3 Cable and Connector Assignment

- For connecting to the SIVAPAC connector on the backplane: [Table 122](#)
- For connecting to the connector panels using RJ45 jacks: [Table 123](#)
- For U.S. only: For connecting to the connector panels with a CHAMP jack: [Table 124](#)

Table 135: TMDID2 (for selected countries only) - SIVAPAC Connector Assignment on the Backplane

Pair	a-Wire (Tip)	b-Wire (Ring)	SIVAPAC Connector	TMDID2		MDFU-E	Notes
1	wht/ blu		1	1a	Port 1	1a	
		blu/ wht	23	1b		1b	
2	wht/ ora		3	2a	Port 2	2a	

Legacy Hardware

Pair	a-Wire (Tip)	b-Wire (Ring)	SIVAPAC Connector	TMDID2		MDFU-E	Notes
		ora/ wht	4	2b		2b	
3	wht/ grn		5	3a	Port 3	3a	
		grn/ wht	6	3b		3b	
4	wht/ brn		7	4a	Port 4	4a	
		brn/ wht	8	4b		4b	
5	wht/ gry		9	5a	Port 5	5a	
		gry/ wht	10	5b		5b	
6	red/ blu		11	6a	Port 6	6a	
		blu/ red	12	6b		6b	
7	red/ ora		13	7a	Port 7	7a	
		ora/ red	14	7b		7b	
8	red/ grn		15	8a	Port 8	8a	
		grn/ red	16	8b		8b	
9	red/ brn		17		free		
		brn/ red	18				
10	red/ gry		19		free		
		gry/ red	20				
11	blk/ blu		24		free		

Pair	a-Wire (Tip)	b-Wire (Ring)	SIVAPAC Connector	TMDID2	MDFU-E	Notes
		blu/blk	25			
12	blk/ora		26		free	
		ora/blk	27			
13	blk/grn		29		free	
		grn/blk	30			
14	blk/brn		31		free	
		brn/blk	32			
15	blk/gry		34		free	
		gry/blk	35			
16	yel/blu		37		free	
		blu/yel	38			

Table 136: TMDID2 (for selected countries only) - Connector Panel Assignment with RJ45 Jacks

RJ45 jack		TMDID2	Notes
No.	Pin		
1	4	1a	
	5	1b	
2	4	2a	
	5	2b	
3	4	3a	
	5	3b	
4	4	4a	

RJ45 jack		TMDID2	Notes
No.	Pin		
	5	4b	
5	4	5a	
	5	5b	
6	4	6a	
	5	6b	
7	4	7a	
	5	7b	
8	4	8a	
	5	8b	
9	4		free
	5		
10	4		free
	5		
11	4		free
	5		
12	4		free
	5		
13	4		free
	5		
14	4		free
	5		
15	4		free
	5		
16	4		free
	5		
17	4		free
	5		
18	4		free

RJ45 jack		TMDID2	Notes
No.	Pin		
	5		
19	4		free
	5		
20	4		free
	5		
21	4		free
	5		
22	4		free
	5		
23	4		free
	5		
24	4		free
	5		

Table 137: TMDID2 (for selected countries only) - Connector Panel Assignment with a CHAMP Jack (for U.S. only)

CHAMP jack	TMDID2			Notes
1	1a	1 Ring	Port 1	
26	1b	1 Tip		
2	2a	2 Ring	Port 2	
27	2b	2 Tip		
3	3a	3 Ring	Port 3	
28	3b	3 Tip		
4	4a	4 Ring	Port 4	
29	4b	4 Tip		
5	5a	5 Ring	Port 5	
30	5b	5 Tip		
6	6a	6 Ring	Port 6	
31	6b	6 Tip		

CHAMP jack	TMDID2			Notes
7	7a	7 Ring	Port 7	
32	7b	7 Tip		
8	8a	8 Ring	Port 8	
33	8b	8 Tip		
9			free	
34				
10			free	
35				
11			free	
36				
12			free	
37				
13			free	
38				
14			free	
39				
15			free	
40				
16			free	
41				

9.2.30.4 Removing the TMDID2 Board

IMPORTANT: This procedure will remove all the channels on this trunk board from service.

NOTICE: Static Sensitive Devices! Observe all precautions for electrostatic discharge.

Remove the TMDID2 board as follows:

1) Deactivate all channels on the board as follows:

- a) Type `DEA-DSSU` and press Enter.
 b) Type the following values, then press Enter.

Field	Value
<code>OFFTYPE</code>	<code>DC</code>
<code>TYPE</code>	<code>PEN</code>
<code>PEN1</code>	<code><PEN1></code>
<code>PEN2</code>	<code><PEN2></code>

IMPORTANT: PEN1 is the PEN of the first channel and PEN2 is the PEN of the last channel on the board.

2) Deactivate the board as follows:

- a) Type `DEA-BSSU` and press Enter.
 b) Type the following values, then press Enter.

Field	Value
<code>OFFTYPE</code>	<code>DC</code>
<code>LTG</code>	<code><1 - 32></code>
<code>LTU</code>	<code><1 - 8></code>
<code>SLOT</code>	<code><1 - 151></code>
<code>REFOFF</code>	<code><blank></code>

- 3) Wait until all LEDs on the board are flashing.
 4) Using the board extractor, unseat the board and remove it from the shelf.

9.2.30.5 Replacing the TMDID2 Board

Replace the TMDID2 board as follows:

- 1) Slide the board into the appropriate slot until you seat it firmly into the backplane connector.

2) Activate the board as follows:

- a) Type `ACT-BSSU` and press Enter.
 b) Type the following values, then press Enter.

Field	Value
<code>ONTYPE</code>	<code>AUL</code>
<code>LTG</code>	<code><1 - 32></code>
<code>LTU</code>	<code><1 - 8></code>
<code>SLOT</code>	<code><1 - 151></code>

3) Activate the channels as follows:

- a) Type `ACT-DSSU` and press Enter.
 b) Type the following values, then press Enter.

Field	Value
<code>ONTYPE</code>	<code>AUL</code>
<code>TYPE</code>	<code>PEN</code>
<code>PEN1</code>	<code><PEN1></code>
<code>PEN2</code>	<code><PEN2></code>

IMPORTANT: PEN1 is the PEN of the first channel and PEN2 is the PEN of the last channel on the board.

9.2.30.6 Verifying the TMDID2 Board

Verify operation of the TMDID2 board by displaying the status of all channels as follows:

- 1) Type `DIS-SDSU` and press Enter.
- 2) Type the following values, then press Enter.

Field	Value
LINK	<Blank>
LTG	<1 - 32>
LTU	<1 - 8>
SLOT	<1 - 151>
CCT	<blank>

9.2.31 TMDNH

The trunk module digital network, OpenScape 4000 (TMDNH) board (see [Figure 118](#)) provides 24 channels for digital trunk applications. The TMDNH board has SIPAC shelf connectors. This board supports the following configurations or applications:



CAUTION: For lightning protection see [Section 2.3, "Lightning Protection"](#).

- T1 interface: When configured as a T1 interface a TMDNH board can support 24-channel associated signaling (CAS), also known as robbed bit signaling, voice, fax or data trunks operating end-to-end with a similarly configured T1 interface.
- ISDN primary rate interface (PRI): When configured as a PRI a TMDNH board can support 23 channels of voice, data or fax between a system and interexchange carriers (for example, AT&T or MCI) or local exchange carriers (for example, Pacific Bell or USWEST). A TMDNH board also supports the National ISDN 2 primary rate interface (NI-2 PRI) protocol.
- ISDN CorNet-N interface: When configured as an ISDN CorNet-N interface a TMDNH board can support 23 channels of voice, data or fax between OpenScape 4000 systems using CorNet, the company proprietary private networking protocol.
- OpenScape 4000 systems provide CorNet-NQ protocol for QSIG private networking connectivity. CorNet-NQ uses a TMDNH board configured as a CorNet-N interface.
- ISDN CorNet-VN interface: The TMDNH board can be configured to support CorNet-VN operation.

9.2.31.1 LED Indications

[Figure 118](#) shows the LED indicators on the front panel of the TMDNH board.

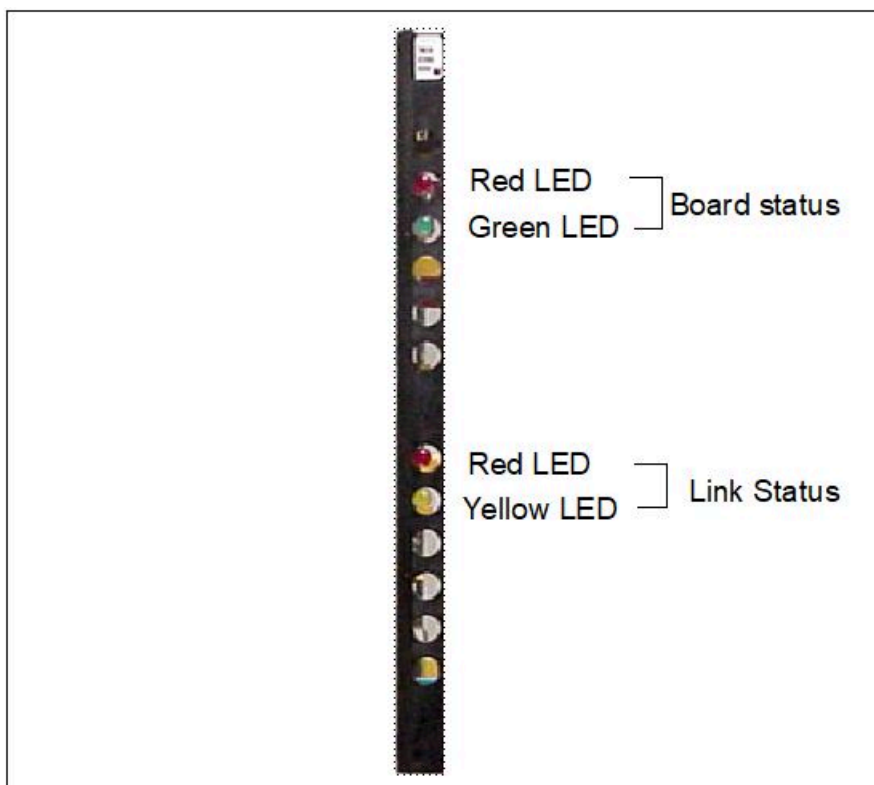

Figure 149: TMDNH Board Front Panel

Table 125 lists the board status LEDs on the front panel of the TMDNH board.

Table 138: TMDNH Board, Board Status LED Indications

Red LED	Green LED	Board Status Indications
On	Off	The board has initial power applied.
Flashing	Off	The board is being loaded with loadware.
On	Off	The board is defective or out-of-service.
Off	On	The board is operational and all channels are inactive.
Off	Flashing	The board is operational and one or more channels are active.

Table 126 lists the link status LEDs on the front panel of the TMDNH board. These LEDs provide the status of the T1 or ISDN link.

Table 139: TMDNH Board, Link Status LED Indications

Red LED	Yellow LED	Link Status Indications
On	Off	The link is in a red alarm condition.
Off	On	The link is in a yellow alarm condition.

Red LED	Yellow LED	Link Status Indications
Off	Off	The link is not in an alarm condition.

9.2.31.2 Removing the TMDNH Board

IMPORTANT: This procedure removes all the channels on this trunk board from service.

NOTICE: Static Sensitive Devices! Observe all precautions for electrostatic discharge.

Remove the TMDNH board as follows:

IMPORTANT: For ISDN applications, first deactivate the B channels, and then deactivate the D channel.

To remove the TMDNH board:

1) Deactivate all channels as follows:

- a) Type `DEA-DSSU` and press Enter.
- b) Type the following values, then press Enter.

Field	Value
OFFTYPE	DC
TYPE	PEN
PEN1	<PEN1>
PEN2	<PEN2>

IMPORTANT: PEN1 is the PEN of the first channel and PEN2 is the PEN of the last channel on the board.

2) Deactivate the board as follows:

- a) Type `DEA-BSSU` and press Enter.
- b) Type the following values, then press Enter.

Field	Value
OFFTYPE	DC
LTG	<1 - 32>
LTU	<1 - 8>
SLOT	<1 - 151>
REFOFF	<blank>

The board is deactivated when the yellow LED is lit and the other LEDs are off.

3) Before removing the board, ensure that the red board status LED is lit, remove the board.

If the red board status LED does not light within 30 seconds, repeat steps [2a](#) and [2b](#). If the red board status LED still does not light within 30 seconds, remove the board.

9.2.31.3 Replacing the TMDNH Board

To replace the TMDNH board:

- 1) Slide the board into the appropriate slot until it seats firmly into the backplane connector.
- 2) Activate the board as follows:

- a) Type ACT-BSSU and press Enter.
- b) Type the following values, then press Enter.

Field	Value
ONTYPE	AUL
LTG	<1 - 32>
LTU	<1 - 8>
SLOT	<1 - 151>

IMPORTANT: For ISDN applications, first activate the D channel, and then activate the B channels.

- 3) Activate the channels as follows:

- a) Type ACT-DSSU and press Enter.
- b) Type the following values, then press Enter.

Field	Value
ONTYPE	AUL
TYPE	PEN
PEN1	<PEN1>
PEN2	<PEN2>

IMPORTANT: PEN1 is the PEN of the first channel and PEN2 is the PEN of the last channel on the board.

9.2.31.4 Verifying the TMDNH Board

To verify the operation of the TMDNH board:

- 1) Confirm that the LPB LED (red) stops flashing.
- 2) Confirm that the second LED (red) from the top comes on.
What is the second LED. If this is labeled, let's call it out.
- 3) Confirm that the second LED (red) goes off.
- 4) Confirm that the top LED (green) lights.
- 5) Confirm that the red board status LED stops flashing and goes off.
- 6) Confirm that the green board status LED comes on or is flashing.

9.2.32 TMEM

The TMEM board contains four bothway E&M tie-line connections. These circuits handle the incoming and outgoing traffic between two PABXs.



CAUTION: For lightning protection see [Section 2.3, "Lightning Protection"](#).

If used as a main PABX circuit or satellite PABX circuit with WTK1 signaling (AC carrier frequency signaling system), it is used to handle the incoming and outgoing internal, exchange and consultation traffic between a main system and a satellite PABX.

The external interface to the remote system is provided by the 8-wire line for voice transmission and signaling (EA/EB-wires, MA/MB-wires, for sending and receiving respectively).

Signaling is performed with direct voltage by means of the monitoring lines E and M. Additionally, DTMF signals may be used for dialing and for WTK1 secondary signals.

The wires must be reversed to the remote system as follows:

- EA crossed with MA
- EB crossed with MB
- E crossed with M

Signaling is provided by means of 4-wire lines in VF mode or in multiplex mode, such as PCM systems with signal converters.

IMPORTANT: When assigning the slots into which the TMEM is to be plugged, always ensure that the adjacent slot on the right is only equipped with a board which does not require a line to the MDF, for example, a ring generator.

9.2.32.1 Board Variants

Q2012-X100 FRG/Austria for WTK1 signaling

9.2.32.2 Carrier Frequency and Ear & Mouth Modes

Signaling is provided with direct voltage by means of the control wires E and M for connection setup, connection clear-down, pulse dialing, and remote blockage. DTMF dialing is also possible.

9.2.32.3 WTK 1 Mode

Primary signals are transmitted as direct voltage pulses by means of the control wires E and M; secondary signals are transmitted as DTMF tones.

Internal, exchange, and transit connections may be set up directly to the satellite PABX or through the attendant console.

Additional boards required for DTMF signaling: SIU type 2

LW designation on HD: APSP/LTG/LG42/PZGTEMT0

9.2.32.4 Configuring the TMEM Board on the Main PABX Circuit Using AMOs

- AMO COT
ANS&NTON&KNOR; possibly: CHRT
- AMO LWPAR
Circuit type = NWWTK
Pulse/pause times for DTMF dialing:
PUTM = 80 ms
PATM = 80 ms
Pause between end-of-dial initial pulse and evaluated end of dial:
EDP = 100 ms
(this value may have to be increased in the case of connections by means of line transformers, such as high voltage lines)
- AMO TACSU (for X100)
Device type: DEV = MAINVFSS
COFIDX = 0 FRG short line
COFIDX = 1 FRG long line (-2dB)
COFIDX = 2 Austria

9.2.32.5 Configuring the TMEM Board on the Satellite PABX Using AMOs

- AMO COT
ANS&NTON&KNOR&ASAT&CONS; optionally: CHRT
- AMO LWPAR
as for main PABX
- AMO TACSU
Device type: DEV = SATVFSS
COFIDX see main PABX

9.2.32.6 TMEMW and TMEMUS Board LED Indications

The front panel of the TMEM board has four channel and blocking status LEDs. [Table 127](#) provides TMEMW or TMEMUS board LED indications.

Table 140: TMEMW or TMEMUS Board LED Indications

LED	State	Indication
All (green)	Off	The channel is idle, ready to use.
	On	The channel is seized by call processing software.
	Slow flash	The channel is deactivated by software.

LED	State	Indication
	Medium flash	The channel is deactivated either manually or by software or the channel is not configured.

9.2.32.7 Connectors and Switches

The TMEMW or TMEMUS board has:

- Four front panel channel and blocking switches.
- Switch packs for standard M signaling

9.2.32.8 Removing the TMEM Board

IMPORTANT: This procedure will remove all the channels on this trunk board from service.

NOTICE: Static Sensitive Devices! Observe all precautions for electrostatic discharge.

To remove the TMEM board:

1) Deactivate all channels as follows:

- a) Type `DEA-DSSU`, then press Enter.
 - b) Type the following values, then press Enter.
- | Field | Value |
|----------------------|---------------------------|
| <code>OFFTYPE</code> | <code>DC</code> |
| <code>TYPE</code> | <code>PEN</code> |
| <code>PEN1</code> | <code><PEN1></code> |
| <code>PEN2</code> | <code><PEN2></code> |

IMPORTANT: PEN1 is the PEN of the first channel and PEN2 is the PEN of the last channel on the board.

2) Deactivate the board as follows:

- a) Type `DEA-BSSU` and press Enter.
 - b) Type the following values, then press Enter.
- | Field | Value |
|----------------------|------------------------------|
| <code>OFFTYPE</code> | <code>DC</code> |
| <code>LTG</code> | <code><1 - 32></code> |
| <code>LTU</code> | <code><1 - 8></code> |
| <code>SLOT</code> | <code><1 - 151></code> |
| <code>REFOFF</code> | <code><blank></code> |

3) Using the board removal and replacement tool, unseat the board and remove it from the shelf.

9.2.32.9 Replacing the TMEM Board

To replace the TMEM board:

- 1) Ensure that the straps on the replacement TMEM board are set to the same setting as the defective board.

IMPORTANT: The TMEMUS board E&M signaling is configured by software and hardware.

- 2) Slide the board into the appropriate slot until you seat it firmly into the backplane connector.

- 3) Activate the board as follows:

- a) Type ACT-BSSU and press Enter.

- b) Type the following values, then press Enter.

Field	Value
ONTYPE	AUL
LTG	<1 - 32>
LTU	<1 - 8>
SLOT	<1 - 151>

- 4) Activate the channels as follows:

- a) Type ACT-DSSU, then press Enter.

- b) Type the following values, then press Enter.

Field	Value
ONTYPE	AUL
TYPE	PEN
PEN1	<PEN1>
PEN2	<PEN2>

IMPORTANT: PEN1 is the PEN of the first channel and PEN2 is the PEN of the last channel on the board.

9.2.32.10 Verifying the TMEM Board

To verify the operation of the TMEM board, display its status as follows:

- 1) Type DIS-SDSU, then press Enter.

- a) Type the following values, then press Enter.

Field	Value
STATUS	ALL
LINK	<blank>
TYPE	PEN
LEVEL	PER3
LTG	<1 - 32>
LTU	<1 - 8>
SLOT	<1 - 151>
CCT	<0 - 15>

- 2) Verify that all the green LEDs on the board are off.

9.2.32.11 MDF Punch-Down Assignments, U.S.

Table 128 shows the TMEMW and TMEMUS boards punch-down assignments.

Table 141: TMEM Board Punch-Down Assignments

Pair No.	Wire Color	Channel No.	Lead Designation
1	WHT-BLU BLU-WHT	00	T1 R1
2	WHT-ORG ORG-WHT	01	T1 R1
3	WHT-GRN GRN-WHT	02	T1 R1
4	WHT-BRN BRN-WHT	03	T1 R1
5	WHT-SLT SLT-WHT	00	T R
6	RED-BLU BLU-RED	01	T R
7	RED-ORG ORG-RED	02	T R
8	RED-GRN GRN-RED	03	T R
9	RED-BRN BRN-RED	00	M E
10	RED-SLT SLT-RED	01	M E
11	BLK-BLU BLU-BLK	02	M E
12	BLK-ORG ORG-BLK	03	M E

9.2.33 TMEMW and TMEMUS

IMPORTANT: With the HiPath 4000 V4 the TMEMW board (Q2092) will be replaced by the TMEW2 board (Q2292).

This section describes the functions and features of the trunk module for ear and mouth, world (TMEMW) and trunk module for ear and mouth, United States (TMEMUS). It also provides procedures for removing, replacing, and verifying these boards.



CAUTION: For lightning protection see [Section 2.3, "Lightning Protection"](#).

9.2.33.1 Functional Description

The TMEUS or TMEW board provides four tie-line connections (4-wire type I E&M signaling) between the OpenScape 4000 and other Hicom 300 communication servers (CSs) or private branch exchanges (PBXs).

IMPORTANT: The TMEUS board is used in the United States only.

Figure 119 shows an interface block diagram of a TMEUS or TMEW board.

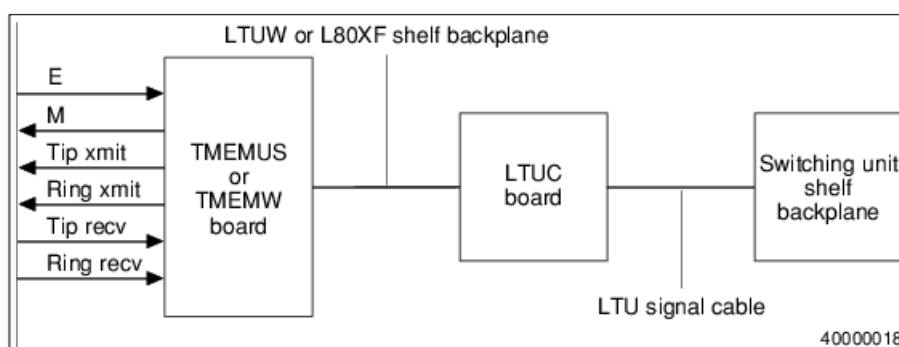

Figure 150: TMEUS Board Block Diagram

9.2.33.2 LED Indications

The front panel of the TMEW or TMEUS board ([Figure 120](#)) contains 4 channel and blocking status LEDs. [Table 129](#) provides TMEW or TMEUS board LED indications.

Table 142: TMEW or TMEUS Board LED Indications

LED	State	Indication
All (green)	Off	The channel is idle, ready to use.
	On	The channel is seized by call processing software.
	Slow flash	The channel is deactivated by software.
	Medium flash	The channel is deactivated either manually or by software or the channel is not configured.

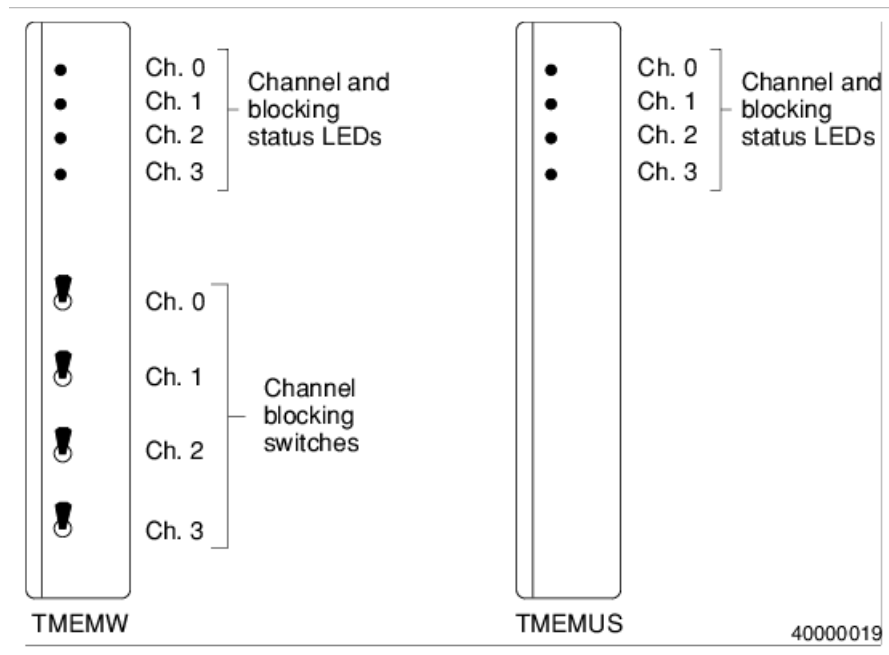

Figure 151: TMEMW and TMEMUS Board Front Panel

9.2.33.3 Connectors and Switches

The TMEMW or TMEMUS board (Figure 120) contains:

- Four front panel channel and blocking switches (Figure 121 and Figure 122)
- Switch packs for standard M signaling

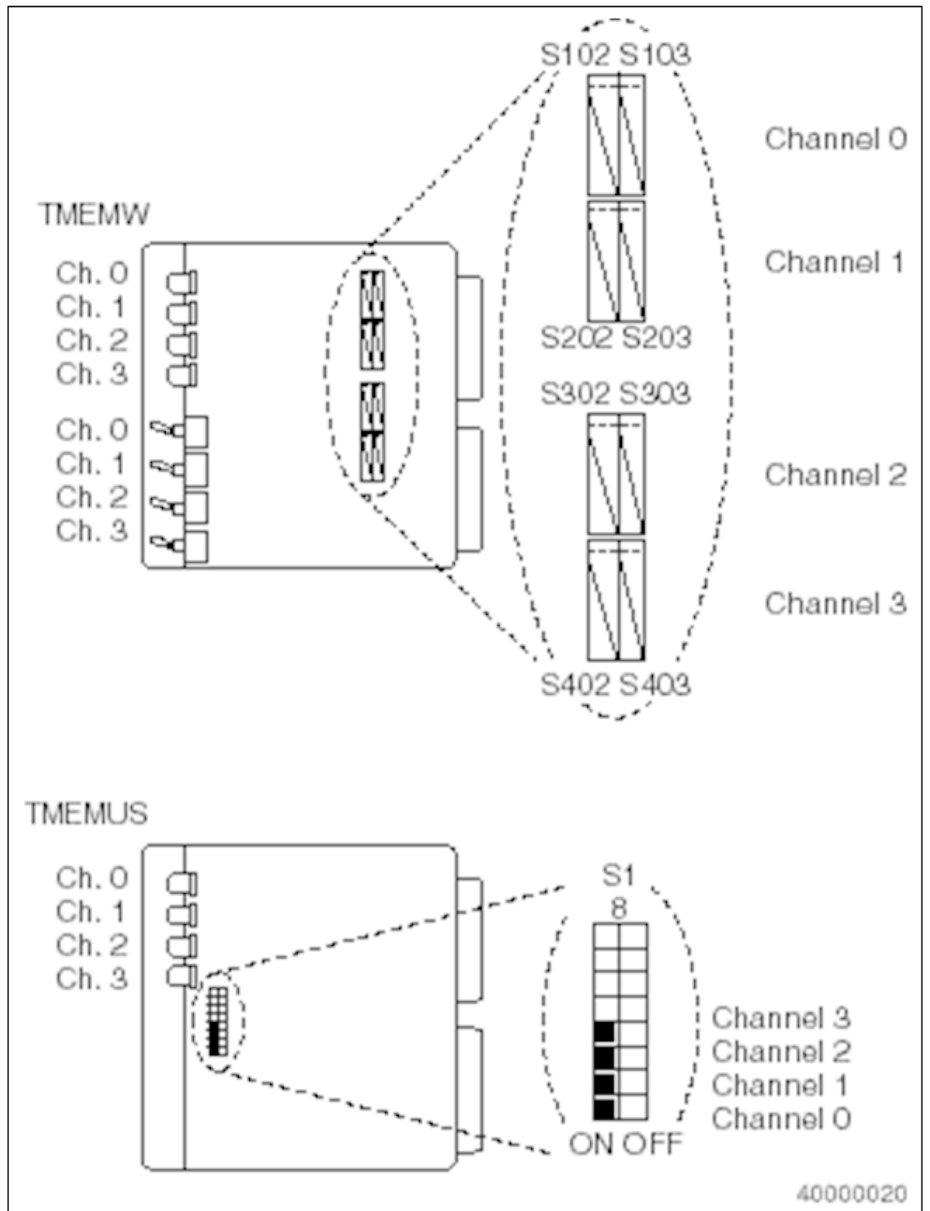

Figure 152: TMEMW and TMEMUS Board Jumper Settings for Standard M Signaling (ON)

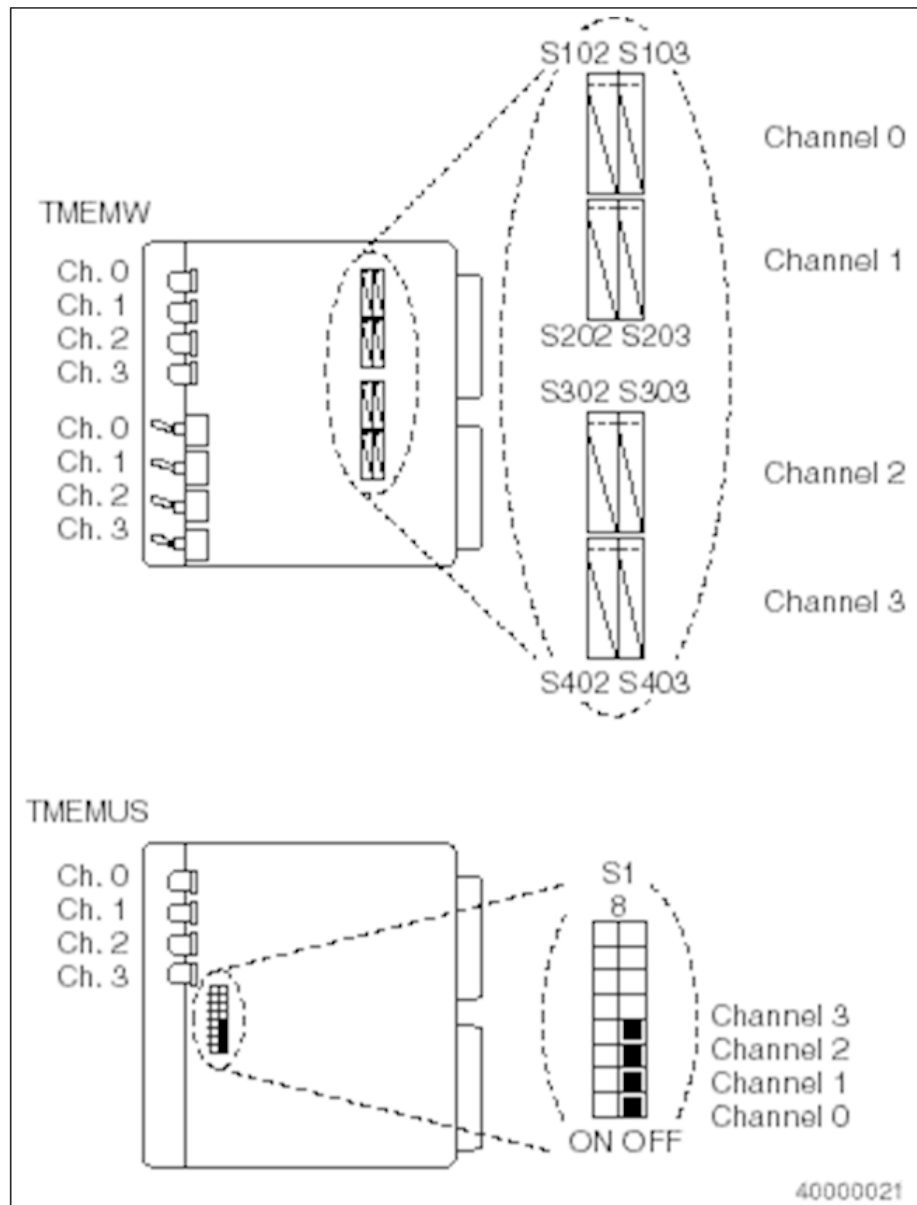

Figure 153: TMEMW and TMEMUS Board Jumper Settings for Inverted M Signaling (OFF)

9.2.33.4 Removing the TMEMW or TMEMUS Board

IMPORTANT: This procedure removes all the channels on this trunk board from service.

NOTICE: Static Sensitive Devices! Observe all precautions for electrostatic discharge.

Remove the TMEMW or TMEMUS board as follows:

1) Deactivate all channels as follows:

a) Type `DEA-DSSU`, then press Enter.

b) Type the following values, then press Enter.

Field	Value
OFFTYPE	DC
TYPE	PEN
PEN1	<PEN1>
PEN2	<PEN2>

IMPORTANT: PEN1 is the PEN of the first channel and PEN2 is the PEN of the last channel on the board.

2) Deactivate the board as follows:

a) Type `DEA-BSSU` and press Enter.

b) Type the following values, then press Enter.

Field	Value
OFFTYPE	DC
LTG	<1 - 32>
LTU	<1 - 8>
SLOT	<1 - 151>
REFOFF	<blank>

3) Using the board extractor, unseat the board and remove it from the shelf.

9.2.33.5 Replacing the TMEMW or TMEMUS Board

Replace the TMEMW or TMEMUS board as follows:

1) Ensure that the straps on the replacement TMEMW board are set to the same setting as the defective board.

IMPORTANT: The TMEMUS board E&M signaling is configured by software and hardware.

2) Slide the board into the appropriate slot until you seat it firmly into the backplane connector.

3) Activate the board as follows:

a) Type `ACT-BSSU` and press Enter.

b) Type the following values, then press Enter.

Field	Value
ONTYPE	AUL
LTG	<1 - 32>
LTU	<1 - 8>
SLOT	<1 - 151>

4) Activate the channels as follows:

a) Type `ACT-DSSU`, then press Enter.

b) Type the following values, then press Enter.

Field	Value
ONTYPE	AUL
TYPE	PEN
PEN1	<PEN1>

PEN2 <PEN2>

IMPORTANT: PEN1 is the PEN of the first channel and PEN2 is the PEN of the last channel on the board.

9.2.33.6 Verifying the TMEW or TMEUS Board

Verify the operation of the TMEW or TMEUS board by displaying its status as follows:

- 1) Type DIS-SDSU, then press Enter.
- 2) Type the following values, then press Enter.

Field	Value
STATUS	ALL
LINK	<blank>
TYPE	PEN
LEVEL	PER3
LTG	<1 - 32>
LTU	<1 - 8>
SLOT	<1 - 151>
CCT	<0 - 15>
- 3) Verify that all the green LEDs on the board are off.

9.2.33.7 MDF Assignments

Table 130 lists the TMEW and TMEUS boards U.S. MDF punch-down assignments.

Table 143: TMEW and TMEUS Boards MDF Assignments

Pair No.	Wire Color	Channel No.	Lead Designation
1	WHT-BLU BLU-WHT	00	T1 R1
2	WHT-ORG ORG-WHT	01	T1 R1
3	WHT-GRN GRN-WHT	02	T1 R1
4	WHT-BRN BRN-WHT	03	T1 R1
5	WHT-SLT SLT-WHT	00	T R
6	RED-BLU BLU-RED	01	T R
7	RED-ORG ORG-RED	02	T R

Pair No.	Wire Color	Channel No.	Lead Designation
8	RED-GRN GRN-RED	03	T R
9	RED-BRN BRN-RED	00	M E
10	RED-SLT SLT-RED	01	M E
11	BLK-BLU BLU-BLK	02	M E
12	BLK-ORG ORG-BLK	03	M E

9.2.34 TMEW2

The trunk module for E&M world (TMEW2) board provides four tie-line connections (4-wire type I E&M signaling) between the OpenScape4000 and other OpenScape 4000 systems or private branch exchanges (PBXs).



CAUTION: For lightning protection see [Section 2.3, "Lightning Protection"](#).

E&M leads are used for signalling between PBXs at two different locations. Signalling between TIE trunks is performed by the E (for Ear or for rEceive) and M (for Mouth or transMit) leads.

The M lead transmits a ground, open or -48V signal. The circuitry on the board converts the logic signal (+5V OR 0V) from the microprocessor through the SICOFI latch outputs. Conversely the E-lead which connects to the remote PBX M lead, receives the -48V, open or ground levels and converts them to +5/0 voltage levels. The signalling protocol is system software programmed as Delay Dial, Wink Start (most common choice), Immediate Start, and so on. The on-board loadware microprocessor handles the E & M signalling protocol through the SICOFI.

For standard Type 1 signalling, when E/M is connected to signalling equipment, an offhook M lead is -48V, while onhook is ground. When two TMEW2s are connected back-to-back (M lead to E lead), TYPE 1A signalling should be selected where offhook M lead is ground and onhook is OPEN.

The order number for TMEW2 is S30810-Q2327-X182.

9.2.34.1 Functions and Features for Target Countries

The TMEW2 has the following analog trunk interface functions:

- TYPE 1, 2, 1A, DC5 E & M signalling and Low level supervision
- Programmable selection of type of Signalling methods
- Programmable transmit and receive gains

- Separate transmit and receive voice pairs - 4 wires
- Optional 2 wires voice path is available for future target countries application

The TMEW2 has the following system features:

- U-law or A-law companding of the voice signal
- Access to PCM highways with flexible time slot channel selection
- HDLC link to communicate with the PBXs switching unit

9.2.34.2 Description of Interfaces

There are three main functional boundaries to the TMEW2: board

- Analog E & M trunk interface
- Channel and voice-path interface
- Common control interface

9.2.34.3 LED Indications

The front panel of the TMEW2 board features two LEDs (red and green). [Table 32](#) lists the LED indications during the TMEW2 board startup procedure.

Table 144: TMEW/TMEMUS Boards, LED Indications

Red LED	Green LED	Indication
On	Off	Power supply available
Flashing	Off	Software is being loaded to the board.
On	Off	The board is defective or out-of-service.
Off	On	The board is operational and all channels are assigned.
Off	Flashing	The board is operational and one or more of the channels are assigned.

9.2.34.4 Configuring the Board

AMO BCSU must be modified so that the action CHA-BCSU (change) can be used to reconfigure boards of different types. When replacing a TMEW board with a TMEW2 board, configure the board as follows:

- 1) Turn off the lines on the board.
- 2) Turn off the board.
- 3) Reconfigure the board.
- 4) Assign the expanded line data to the lines by means of the index (CIRCIDX).
- 5) Turn on the lines and the board.

Table 145: TMEW2, Nominal Loss and Overload Point of Half Connections

	Transmit Path A->D (Li or PE)			Receive Path D->A (Lo or PA)			
Gain Index	Normal Loss (dB)	Input Relative Level at T1/R1 (dBr)	Input Overload Point to Produce D.F.S (dBr)	Normal Loss (dB)	Output Relative level at T/R (dBr)	Output Overload Point Produced by D.F.S. (dBr)	Countries
0 *)	-3.5	-3.5	-0.5	+3.5	-3.5	-0.5	A-law Italy Finland Austria France Greece Sweden
1	0	0	+3	+6	-6	-3	U.S.A. **) - U-law'
2	-1.5	-1.5	+1.5	+1.5	-1.5	+1.5	Australia***) -A-law
3	-2.5	-2.5	+0.5	+4.5	-4.5	-1.5	Germany - A-law
4	+0.5	+0.5	+3.5	+4.5	-4.5	-1.5	U.K. - 'A-law'
*)	Default gain index used before TMEW2 board is configured to any specific countries						
**)	Gain index reserved for the USA, but TMEW2 is not sold to the U.S.A. as stated in TMEW2 A30 document						
***)	Gain index reserved for Australia, but TMEW2 will not be used in Australia						

Weighted Noise (I-ETS 300005)

Table 34 lists the weighted noise level of the TMEW2 board.

Table 146: Weighted noise level

Connection Type Noise Level (dBm0p)	
Analog-to-Digital	66

Connection Type Noise Level (dBm0p)	
Digital-to-Analog	75

Table 35 lists the transverse conversion loss (TCL) of the TMEW2 board.

Table 147: Transverse conversion loss

Frequency (Hz)	Min (dB)
300 - 3400	46

9.2.34.5 Connector Pin Assignments

Table 36 lists the upper connector pin assignments of the TMEW2 board.

Table 148: Upper connector pin assignment

Pin #	Signal Name	Pin #	Signal Name	Pin #	Signal Name
41	NC	21	+5V	01	T1-1
42	NC	22	GND	02	+12V
43	NC	23	R1-1	03	T1-2
44	NC	24	E(1)/E(2)-3	04	R1-2
45	NC	25	M(1)/SG-3	05	T1-3
46	NC	26	E(1)/E(2)-4	06	R1-3
47	NC	27	M(1)/SG-4	07	T1-4
48	NC	28	GND	08	R1-4
49	NC	29	S3AN(LL)/M(2)-1	09	T-1
50	NC	30	S3AB(LL)/SB(2)-1	10	R-1
51	NC	31	S3AN(LL)/M(2)-2	11	T-2
52	NC	32	S3AB(LL)/SB(2)-2	12	R-2
53	NC	33	GND	13	T-3
54	NC	34	S3AN(LL)/M(2)-3	14	R-3
55	NC	35	S3AB(LL)/SB(2)-3	15	T-4
56	NC	36	-5V	16	R-4
57	NC	37	S3AN(LL)/M(2)-4	17	E(1)/E(2)-1
58	NC	38	S3AB(LL)/SB(2)-4	18	M(1)/SG-1

Pin #	Signal Name	Pin #	Signal Name	Pin #	Signal Name
59	NC	39	GND	19	E(1)/E(2)-2
60	NC	40	+5V	20	M(1)/SG-2

Table 37 lists the middle connector pin assignments of the TMEW2 board.

Table 149: Middle connector pin assignment

Pin #	Signal Name
1	GND
2	+5VL

Table 38 lists the lower connector pin assignments of the TMEW2 board.

Table 150: Lower connector pin assignment

Pin #	Signal Name	Pin #	Signal Name	Pin #	Signal Name
41	NC	21	+5V	01	RING
42	NC	22	GND	02	+12V
43	NC	23	GND	03	-48V
44	NC	24	DIAL1	04	-60V
45	TOUT*	25	DIAL2	05	+60V
46	FBPE	26	WGSYN	06	U-SLIC
47	TRST*	27	RGSYN	07	RCLK
48	TCK*	28	GND	08	RAC
49	TMS*	29	PRS	09	BA0
50	TDI*	30	BA1	10	RGCL
51	TDO*	31	HO1	11	RGD
52	HO3	32	HO0	12	BA6
53	HO2	33	GND	13	HD0
54	NC	34	BA2	14	BA5
55	NC	35	BA3	15	CKA
56	NC	36	-5V	16	CLS
57	HI3	37	FMB	17	HI1
58	HI2	38	HI0	18	BA4

Pin #	Signal Name	Pin #	Signal Name	Pin #	Signal Name
59	NC	39	GND	19	HDI
60	NC	40	+5V	20	-12V
* used for boundary scan testing					

9.2.34.6 Removing the TMEW2 Board

IMPORTANT: This procedure will remove all the channels on this trunk board from service.

NOTICE: Static Sensitive Devices! Observe all precautions for electrostatic discharge.

To remove the TMEW2 board:

1) Deactivate all channels as follows:

- a) Type `DEA-DSSU`, and then press Enter.
- b) Type the following values, and then press Enter.

```
Field      Value
OFFTYPE   DC
TYPE      PEN
PEN1      <PEN1>
PEN2      <PEN2>
```

IMPORTANT: PEN1 is the PEN of the first channel and PEN2 is the PEN of the last channel on the board.

2) Deactivate the board as follows:

- a) Type `DEA-BSSU` and press Enter.
- b) Type the following values, and then press Enter.

```
Field      Value
OFFTYPE   DC
LTG       <1 - 32>
LTU       <1 - 8>
SLOT      <1 - 151>
REFOFF    <blank>
```

3) Using the board removal and replacement tool, unseat the board and remove it from the shelf.

9.2.34.7 Replacing the TMEW2 Board

To replace the TMEW2 board:

- 1) Ensure that the straps on the replacement TMEW2 board are set to the same setting as the defective board.

IMPORTANT: The TMEW2 board E&M signaling is configured by software and hardware.

- 2) Slide the board into the appropriate slot until you seat it firmly into the backplane connector.
- 3) Activate the board as follows:

- a) Type ACT-BSSU and press Enter.
- b) Type the following values, and then press Enter.

Field	Value
ONTYPE	AUL
LTG	<1 - 32>
LTU	<1 - 8>
SLOT	<1 - 151>

- 4) Activate the channels as follows:

- a) Type ACT-DSSU, and then press Enter.
- b) Type the following values, and then press Enter

Field	Value
ONTYPE	AUL
TYPE	PEN
PEN1	<PEN1>
PEN2	<PEN2>

IMPORTANT: PEN1 is the PEN of the first channel and PEN2 is the PEN of the last channel on the board.

9.2.34.8 Verifying the TMEW2 Board

To verify the operation of the TMEW2 board:

- 1) Display the status by typing DIS-SDSU, and then press Enter
- 2) Type the following values, and then press Enter.

Field	Value
STATUS	ALL
LINK	<blank>
TYPE	PEN
LEVEL	PER3
LTG	<1 - 32>
LTU	<1 - 8>
SLOT	<1 - 151>
CCT	<0 - 15>

- 3) Verify that all the green LEDs on the board are off.

9.2.35 TMLBL

The trunk module for local battery lines (TMLBL) board is used for connecting local battery switchboards (drop indicator panels) and local battery telephones.

The board consists of 8 circuits and it can work also as bothway trunk circuits for local battery signalling without DID or with pseudo-DID.



CAUTION: For lightning protection see [Section 2.3, "Lightning Protection"](#).

On tie-trunk circuits (local battery operation), signalling is carried out by means of 25/50-Hz ringing current.

For DTMF dialling to the exchange, a type 2 SIU is required for each line.

At least one ACGEN is required for every line trunk group (LTG). The transmission frequency of the alternating current can be individually set at each associated ACGEN. The TMLBL cannot be operated without an ACGEN. One ac generator provides the ringing current for up to 10 TMLBLboards, that is 80 line circuits.

Functional line length: defined by max. ringing transmission distance, 2 x 9 kΩ

9.2.35.1 LED Indications and Push Buttons

The front panel of the TMLBL board contains eight LEDs and two push buttons. The board has one LED for every line circuit.

To select a line circuit, press the first push button (LED flashes).

To manually block (LED flickers) or unblock the circuit, press the second key.

9.2.35.2 Loadware Variants

[Table 131](#) lists the loadware variants of the TMLBL board.

Table 151: TMLBL Board Loadware Variants

LW Variant	COFIDX Settings in the TACSU AMO	CTRY	Input	Artificial Line	Line Loss	Line
PZGTBOB00		PL	600 Ω	600 Ω	-7/0	long
	1	PL	600 Ω	600 Ω	-5/-2	short
	2	D	220+(820//115nF)	220+(820//115nF)	-7/0	long
	3	D	220+(820//115nF)	220+(820//115nF)	-5/-2	short
	*) 4	PL	600 Ω	600 Ω	0/-7	long
	*) 5	PL	600 Ω	600 Ω	-2/-5	short
	*) 6	PL	220+(820//115nF)	220+(820//115nF)	0/-7	long
	*) 7	PL	220+(820//115nF)	220+(820//115nF)	-2/-5	short

LW Variant	COFIDX Settings in the TACSU AMO	CTRY	Input	Artificial Line	Line Loss	Line
PZGTBOB10		GB	370+(620//310nF)	300+(1000//220nF)	8/2	long
	1	GB	370+(620//310nF)	600 Ω	-5/-1	short
	*) 2	GB	300+(1000//220nF)	370+(620//310nF)	3/-9	-
	3	GB	370+(620//310nF)	370+(620//310nF)	1/-6	long
	*) 4		600 Ω	600 Ω	0/-7	long
	*) 5		600 Ω	600 Ω	-2/-5	short
	*) 6		220+(820//115nF)	220+(820//115nF)	0/-7	long
	*) 7		220+(820//115nF)	220+(820//115nF)	-2/-5	short
*) Connects to a local battery station (otherwise: duplex transmission)						

Table 132 lists the line attenuation values of the TMLBL board.

Table 152: TMLBL Board Line Attenuation Values

Cable wire gauge (mm)	Line impedance (Ω/km)	Line loss (dB/km)	Line length at	
			2 dB (km)	3 dB (km)
0.6	2 x 62.5	1	2	3
0.4	2 x 135	1.8	1.1	1.7

9.2.35.3 Functions of the Board

Operation

- Incoming seizure
AC ringing voltage
The receiver sensitivity ranges from 10 to 90 Hz.
- Answering
Speech path switched through
- Release before answering
Alternating current on the line is interpreted as a release criterion (P1=1!).
If a release criterion (P1=0) is not configured, or if additional ringing is ignored (P8=1), the answering monitoring time parameter must be set (P7 > 0).

- **Outgoing seizure**
AC voltage (25/50 Hz) is applied to the a/b-wires.
- **Release from call status (incoming/outgoing connection)**
Alternating current on the line is interpreted as a release criterion (P1=1!).
If a release criterion (P1=0) is not configured, or if subsequent ringing is ignored (P8=1), the call time supervision parameter must be set (P3 > 0).
Exception: only if both parties can be guaranteed to go on-hook when the call is terminated.
- **Outgoing DTMF dialing**
The DTMF tones are transmitted by the SIU following the outgoing initial seizure ring pulse and a start-of-dial pause.
- **Incoming DTMF dialing**
DTMF dialling tones can be received after incoming seizure. To avoid transmitting the DTMF signals during outgoing line seizure, the COP parameters DTN, PDP3, and NTON must be set. Avoid transmitting DTMF signals during ringing (levels must not be too high!).
- **Outgoing additional ringing**
If line signalling to the exchange is enabled (PAR=OVRA set in COT), an additional ring can be transmitted by dialling the CALL_TO_CO code.
- **Incoming additional ringing before answer**
If P1=0, the additional ringing is interpreted in local battery mode as a connection release with re-seizure (if P8=0), or simply ignored (if P8=1).
For incoming calls with PREFDGTs or MOSIG-DID with DTMF signalling, additional ringing after the end-of-dial signal either leads to an extension of ringing to the attendant console (attendant intercept) or to override/knocking (if P8=3).
- **Incoming additional ringing if busy**
If P1=0, the additional ringing is interpreted in local battery mode as a connection release with re-seizure (if P9=0), or simply ignored (if P9=1).
For special applications, for example, Trading, an audible tone can be switched with P9=2 or 3; the duration and frequency of the audible tone is set with P10 and P11 respectively.
- **Transit connections**
Since the answering criterion is not transmitted back down the transit line, exchange and tie-traffic callers must not be able to reach a local battery line by direct dialling; calls must be extended by the attendant.
To release the line when such calls are terminated, the local battery circuits must either be operated with release criterion signalling or call duration monitoring.

Special Features

Rering signal (only if no release criterion/release acknowledgement; P1,P2=0):

Usage:

- For connecting local battery stations, since only one seizure ring is signalled, which can be overheard. The rering function saves the PABX user having to release the connection and re-seize.

By default, an incoming rering leads to release and re-seizure, that is, the call is re-entered in the call queue. In this case, set the P8 and P9 to 1 so that the rering is ignored, that is, release and re-seizure is prevented (COP=RLSA), or, for additional ringing which remains unanswered (COT=BRAR), backward release by the system or the board loadware (answering/call duration monitoring: P7/P3 <>0).

- For incoming seizure with DGTPR or in pseudo DID, the rering can initiate a specific call to an attendant number, or specifically initiate camp-on/override, if automatic attendant intercept or automatic station camp-on/override are not required (PTIME: P8).
- In Trading systems, the rering function is used in Fig.2-(figure-two-)signalling, in order to initiate an alerting tone at a remote station in calling state.

This feature is implemented according to the feature, flash signal to exchange line. To perform this feature, the user dials the CALL_TO_CO code in consultation mode, the attendant presses the line key.

- For assigning digit analysis result, for example, *8:
AD-WABE:CD=*8,DAR=CALLTOCO,CHECK=N;
- For connecting the line for flash signalling to exchange line:
CHA-COT:COTNO=<COT.number of
TMLBL>,COTTYPE=COTADD,PAR=OVRA;
- For emergency override or emergency release:

This feature is mainly used to clear busy connecting lines for priority calls. The feature is mainly used in civil service networks.

Local Battery Operation

This standard operating mode is used for connections to local battery stations, or to remote (duplex) transmitters.

Lines can be operated without or with release signal (P1=1:"ring off") and release acknowledgment (P2=1).

Since local battery connections usually run by means of single lines or very small trunk groups, users frequently encounter an all-trunks-busy (ATB) state. It is recommended to activate the emergency override or emergency release feature.

- Add local battery operation parameters:
AD-COT:COTNO=aa,PAR=NTON(&BRAR&CHRT&LWNC&IEVT&OVRA);
AD-COP:COPNO=bb,COPPAR=RLSA&FDGT&LSUP;
COP-PTIME:48,c;
CHA-
PTIME:TYPE=REST,INIBLOCK=c,BTYPE=PARA,P3=0,P7=0,P8=1;
AD-
TACSU:PEN=?-?-?-?,ANZ=?,COTNO=aa,COPNO=bb,...DEVTYPE=TC,DEV=OB,
DGTPR=?atnd code/
stn?,SUPPRESS=0,DGTCNT=0,...CIRCIDX=c,...,DIALTYPE=DP-
DP,
DIALVAR=0-0;

Figure-Two-Signalling

This operating mode is used for Trading systems. It is a variant of the local battery operating mode, in which the lines are operated without release signals, and the prefixed digits correspond to a DIGITE terminal, which can be answered by pressing a line key on the Trade boards.

The main function of figure-two-signalling is the possibility of initiating a rering while in talking state. The ringing signal is transmitted to the called party as an audible tone signal (similar to ringback tone. Settings: P9, P10, P11).

Both incoming and outgoing rerings are possible.

Lines in both systems can only be released by the users.

- Add parameters for figure-two-signalling (initial implementation: UK):
 AD-COT:COTNO=aa, PAR=NTON&OVRA (&BRAR&CHRT&LWNC&IEVT) ;
 AD-COP:COPNO=bb, COPPAR=RLSA&FDGT&LSUP ;
 COP-PTIME:48, c ;
 CHA-
 PTIME:TYPE=REST, INIBLOCK=c, BTYPE=PARA, P3=0, P7=0, P8=1, P9=3, P10=3, P11=2 ;
 AD-
 TACSU: PEN=?-?-?-?, CNT=?, COTNO=aa, COPNO=bb, . . . DEVTYPE=TC, DEV=OB, DGTPR=?DIGITE-stn?, SUPPRESS=0, DGTCNT=0, . . . CIRCIDX=c, . . . , DIALTYPE=DP-DP, DIALVAR=0-0 ;

Pseudo-DID with DTMF Dialling

Lines operated in local battery mode can also be configured for pseudo-DID with DTMF signals. This is useful if a shortage of better tie-lines or transit lines occurs, or if none exist, and allows the remaining local battery lines in a system to be used as tie-lines. All attendant intercept options must be activated.

In connection with a local battery station, users can call other users in the system without having to route by means of an attendant. The local battery station user simply transmits the DTMF signals down the open line after the initial seizure ring, using an INFO-TIP.

It is recommended to operate these lines with release signalling, to ensure that connections are correctly cleared down, if used as transit connections to tie lines or exchange lines.

If the lines are only configured as internal lines to PABX users, the release signal can be omitted (P1=0). In this case, it makes sense to configure the rering feature (COT=OVRA) in order to be able to initiate camp-on/override or attendant calls if users do not answer or the lines are busy. The attendant intercept options IBSY and IFR must not be set.

- Add parameters for pseudo-DID with DTMF dialling to/from remote transmitter:
 AD-COT:COTNO=aa, PAR=NTON&RCL&INDG&IIDL&IVAC&IBSY&INAU &ITB&IDND&IFR&IDIS&BRAR (&CHRT&LWNC&IEVT&OVRA) ;
 Note: The "ICPTDID" feature must be enabled with the "FEASU" AMO in order for attendant intercept to work!
 AD-COP:COPNO=bb, COPPAR=DTMF&RLSA&LSUP&DTM1 &PDP3 ;
 COP-PTIME:48, c ;

```

CHA-
PTIME:TYPE=REST,INIBLOCK=c,BTYPE=PARA,P1=1,P3=0,P7=0,P8=0,P9=0;
AD-
TACSU: PEN=?-?-?-?,CNT=?,COTNO=aa,COPNO=bb,...DEVTYPE=TC,DEV=OB,
DGTPR=*,SUPPRESS=0,DGTCNT=0,...CIRCIDX=c,...,DIALTYPE=DP-
DP,DIALVAR=0-0;

```

- **Add data for pseudo-DTMF-dialling at local battery stations:**

```

AD-COT:COTNO=aa,PAR=NTON&RCL&INDG&IIDL&IVAC&IBSY&INAU
&ITB&IDND&IFR&IDIS&BRAR (&CHRT&LWNC&IEVT&OVRA) ;

AD-COP:COPNO=bb,COPPAR=RLSA&FDGT&LSUP;
COP-PTIME:48,c;
CHA-
PTIME:TYPE=REST,INIBLOCK=c,BTYPE=PARA,P1=1,P3=0,P7=0,P8=0,P9=0;
AD-
TACSU: PEN=?-?-?-?,CNT=?,COTNO=aa,COPNO=bb,...DEVTYPE=TC,DEV=OB,
DGTPR=*,SUPPRESS=0,DGTCNT=0,...CIRCIDX=c,...,DIALTYPE=DP-
DP,DIALVAR=0-0;

```

9.2.35.4 Configuring the TMLBL Board Using AMOs

To configure the TMLBL board use the following AMOs:

- AMO COP/COT

71/112: outgoing pulse dialling

72/112: outgoing DTMF dialling

```
ADD-COP:71,RLSA&LSUP&TIE&FDGT;
```

```
ADD-COP:72,DTMF&RLSA&LSUP&TIE&DTM1&PDP3;
```

Other useful COP parameters: DITW, DTN, NTON.

```
ADD-COT:112,NTON;
```

Other useful COT parameters: OVRA, CHRT. Note: For attendant intercept on DID calls, the feature classmark value ICPTDND must be set in the FEASU AMO!

- AMO TACSU

Device type designation: DEV=OB, DEVTYPE=TC

```
AMO TACSU:COTNO=112,COPNO=71,COFIDX=0..1
```

CIRCIDX=default assignment to PTIME INIBLOCK: 17

- AMO ZAND

```
AMO ZAND:LWTYPE=TEMW,LWVAR=0 (standard)
```

9.2.35.5 Adding Board Configuration Data

To add board configuration data to the TMLBL board, use the following AMOs:

IMPORTANT: ? denotes customer-specific data; lower case denotes configuration examples.

- **AMO BCSU**
AD-
BCSU:TYPE=PER,LTG=<LTG>,LTU=<LTU>,SLOT=<SLOT>,PARTNO=Q2123-X;
AD-
BCSU:TYPE=ACGEN,LTG=<LTG>,LTU=<LTU>,SLOT=<SLOT>,PARTNO=Q2058-X,
OPMODE=SY50H85V; (for 25 Hz: OPMODE=SY25H85V)
- **AMO ZAND**
AMO ZAND:LWTYPE=TBOB, LWVAR=0 (default)
CHA-ZAND:LWTYPE=TBOB,LWVAR=1 (UK)
- **AMO BUEND**
AD-BUEND:TGRP=xxx,NAME=???,NO=?,RSV=Y;
- **AMO WABE**
AD-WABE:CD=yyy,DAR=TIE (/CO),CHECK=N;
- **AMO RICHT**
AD-RICHT:TYPE=CD,CD=yyy,SVC=VCE,TGRP1=xx,DNNO=?;
- **AMO COT**
AD-COT:COTNO=aa,PAR=NTON&LWNC&IEVT&OVRA;
- **AMO COP**
AD-COP:COPNO=bb,PAR=RLSA&FDGT&LSUP;
- **AMO TACSU**
AD-TACSU:PEN=<lgt>-<ltu>-<slot>-<cct>,CNT=??,COTNO=aa,COPNO=bb,
.....TGRP=xx,.....DEVTYPE=TC,DEV=OB,...DIALTYPE=DP-DP,DIALVAR=0-0;

9.2.36 TMLR

The trunk module loop reversal inter-PABX (TMLR) board offers two bothway tie line circuits for inter-PABX traffic. The circuits handle incoming and outgoing traffic between two PABXs. If necessary, transfer of exchange calls (transit traffic) is also possible.



CAUTION: For lightning protection see [Section 2.3, "Lightning Protection"](#).

The tie line trunk circuit, with feed or loop in idle state, is used in Germany (BRD) and Austria (OES).

The external interface to a remote exchange is a two-wire tie trunk for voice and signaling. Signaling is based on the loop disconnect procedure.

The normal operating range is max. 2 x 1000 Ω. This range may, however, be extended using a negative impedance repeater.

In idle mode, if PABX feeding mode is set, a line monitor can be applied to the line to ascertain the remote exchange's service state.

9.2.36.1 LED Indications

The front panel of the board contains 4 LEDs and 4 keys.

9.2.36.2 DIP-FIX Switches

Table 133 lists the DIP switch settings for the TMLR board.

Table 153: TMLR Board DIP-FIX Switches

Set	DIP-FIX		GermanyA/D -5 dBr D/A -2 dBr	Austria A/D -6 dBr D/A -1 dBr
0	S102	1-2 3-4	ON	OFF
1	S202	1-2 3-4	ON	OFF

9.2.36.3 Signal Exchange

Signal interchange and electrical characteristics are specified as follows:

- Feeding in the idle state with a line monitor, without battery-ground dialing (a/b wires crossed).
- Feeding in the idle state without a line monitor, without battery-ground dialing (a/b wires uncrossed).
- Loop in the idle state (a/b wires uncrossed).
- Loop signaling according to Telecom Australia Specification Ssf 020.

With the SICOFI version (Q2064-X100) of this board, the transmission parameters are adapted to the specification for the country concerned by means of AMO TACSU, parameter COFIDX.

As for the COFI version (Q2064-X) the nominal values of attenuation can be set according to application (Germany, Austria) by means of DIP-FIX switches for TMLR (Q2064-X).

For transit traffic the relative levels are fixed (DIP FIX switch position is irrelevant). A/D 0 dBr and D/A -7 dBr.

Table 134 lists the SICOFI parameters of the TMLR board.

Table 154: SICOFI parameter

COFIDX	CTRY	Level (dBr)		Remark
		0 A/D D/A	0 A/D D/A	
0	OES	-6 -1	0 -7	
1	BRD	-5 -2	0 -7	Short line
2	BRD	-7 0	0 -7	Long line

9.2.37 TMLRB

The trunk module with loop reversal, battery-ground signalling (TMLRB) board is a two-wire interface to analog public network exchanges (central office) for direct inward dialing (loop start signaling criteria).

The board consists of eight circuits. It replaces the TMLSF board.



CAUTION: For lightning protection see [Section 2.3, "Lightning Protection"](#).

9.2.37.1 LED and Key Indications

The busy status of each circuit is indicated by a separate LED.

Key Functions:

The first key selects the circuit. The second key locks the circuit

Line Signaling

The line signaling provides the following:

- Impedance in idle state
- A/b-wire feed
- Loop current detection
- Incoming pulse signal or MFC-R2 / MFC-Socotel through SIU
- Feed voltage reversal
- Timed deactivation of feed voltage
- A/b-wire splitting

[Figure 124](#) and [Figure 125](#) show the side views of two TMLRB board variants.

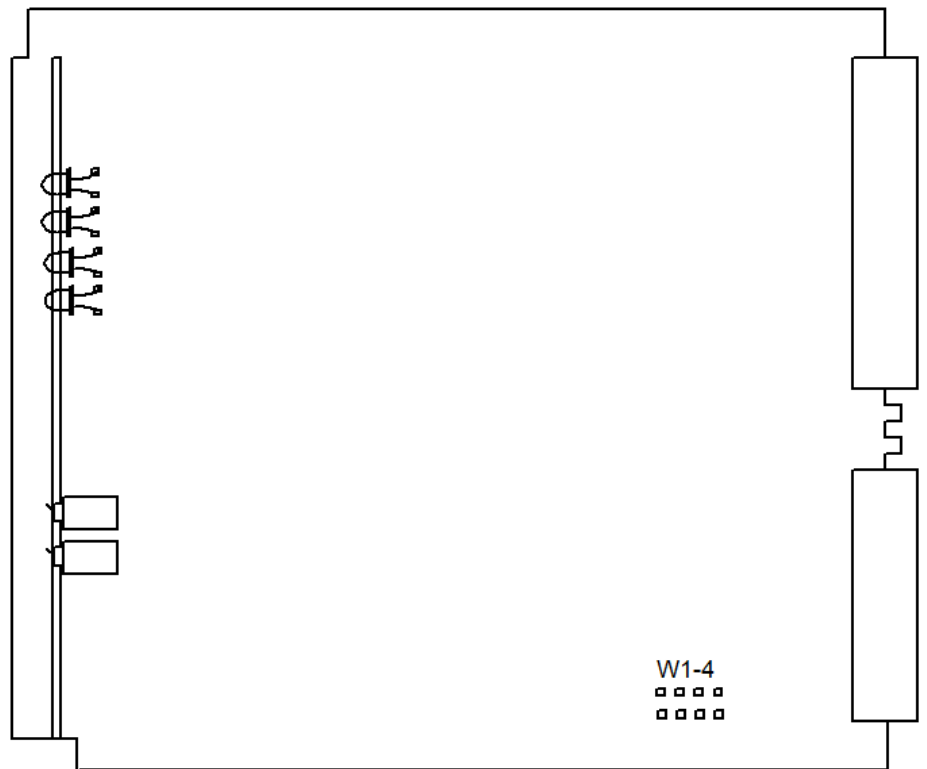

Figure 154: TMLRB Board (Q2286-X)

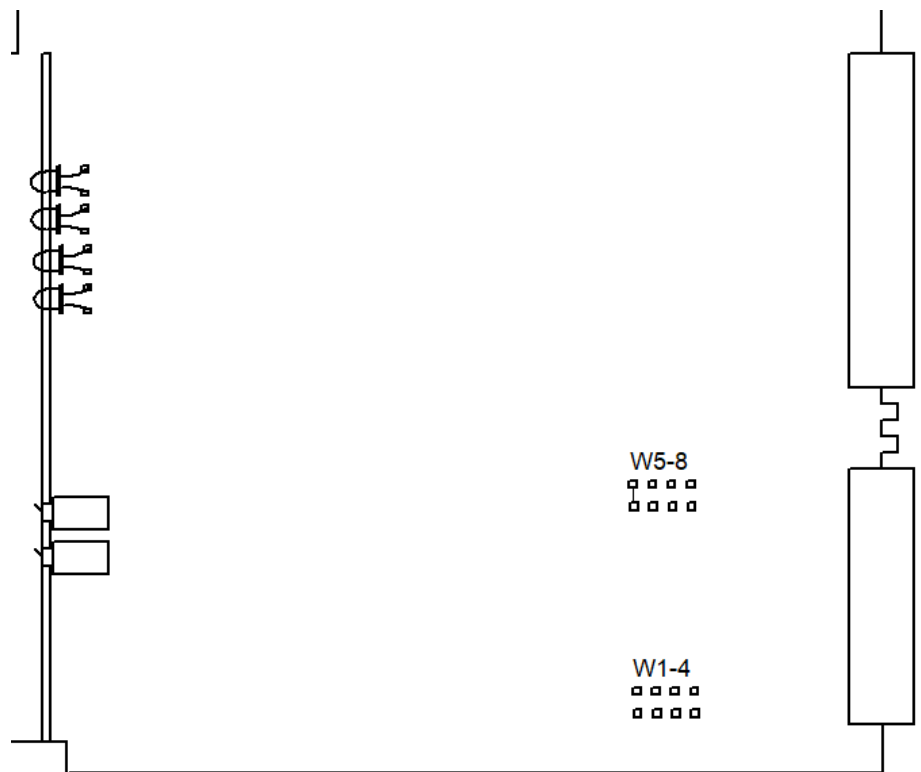

Figure 155: TMLRB (Q2186-X100)

9.2.37.2 Board Variants

Table 135 lists the TMLRB board variants.

Table 155: TMLRB Board Variants

Variant	Country
Q2186-X	RSA, GB
Q2286-X100	Brazil

9.2.37.3 Loadware Variants

Q2286-X

Table 136 lists the loadware of the TMLRB board Q2286-X variant.

Table 156: TMLRB Board Loadware Variant Q2286-X

Country	Input	Artificial Line	Line Loss	Line
GB	370+(620//310nF)	300+(1000//220nF)	-5,0/-1,0	< 3 dB
GB	370+(620//310nF)	300+(1000//220nF)	-8,0/+2,0	#≥ 3 dB
RSA	220+(820//115nF)	220+(820//115nF)	-5,0/ 0	

Q2186-X100

Table 137 lists the loadware of the TMLRB board Q2286-X variant.

Table 157: TMLRB Board Loadware Variant Q2186-X100

Country	Input	Artificial Line	Line Loss
BRA	900	800//50nF	-6,0/-1,0
	900	1000//100nF	-6,0/-1,0
	600	1000//100nF	-6,0/-1,0

Table 138 lists the countries of application for the TMLRB board and its reference boards

Table 158: TMLRB Board and Reference Boards Countries of Application

Country	TMLRB				Reference Board			
	HW Var.	LW Variant	Line length	COFI Index	Name	HW Ref. No.	LW Var PZG..	COFI Index
GB	X	0	long/short	0/1	TMLS F	Q2086-X2	TMLS2	0 / 1

Country	MLRB				Reference Board			
	HW Var. Q2286-	LW Variant PZGTLRBx	Line length	COFI Index	Name	HW Ref. No.	LW Var PZG..	COFI Index
RSA	X	0	long	2	TMLSF	Q2086-X1	TMLS1	2

9.2.38 TMOM2

The trunk module outgoing multipurpose (TMOM2) board is a 4-channel analog interface card that provides connectivity between OpenScape 4000 and various special equipment.



CAUTION: For lightning protection see [Section 2.3, "Lightning Protection"](#).

The TMOM board only works in the outgoing direction.

The TMOM provides connectivity to the following special equipment:

- Code calling/paging system (PSE)
- Dictation equipment (DICT)
- Public address systems (SPKR)
- Recording announcement equipment (RA)
- Entrance telephone (DOOR)
- Night watchman service (NWS)
- Loop transformer for simplified tie line traffic (TIE)

9.2.38.1 Board Functions

The three main functions of the TMOM board are:

- Analog line interface
- Channel and voice path interface
- Common control interface

Analog line interface

The analog line interface is used for signalling between the PBX and special equipment.

Each equipment requires different analog interfaces; from 2-wire connection up to 6-wire connection. The following sections describe the different interfaces.

Paging systems (PSE)

2-Wire connection—for paging systems provides the following features:

- Monitoring
 - By means of a/b-wires with high-impedance dc-loop in the idle state
 - By means of a/b-wires with low-impedance dc-loop clearback detection (release from the paging system).
- Seizure by closing the dc-loop
- Dialing information by means of a/b-wires.
 - There are 2 types of dialling methods:
 - Rotary dialing and DTMF dialing. The timing depends on the LW and is configurable.
- Seizure acknowledge depending on the loop current in the a/b-wires.
- Clearback detection (release from the paging system) even during dialling phases.
- Backward signaling in accordance with ESPA through crossover of the a/b-wires.
- Entry of the central operating console of the paging system signalled by pulsed crossover of the a/b-wires.
- Forward release by disconnecting the loop

3-Wire connection—for paging system provides the following features:

- Monitoring by means of the c-wire.
- Power supplied to the c-wire provided by the paging system
- Earth potential by means of low impedance on the c-wire before seizure by means of loop on the a/b-wires
- Dialing: there are 2 types of dialling methods:
 - Rotary dialing and DTMF dialing. The timings are configurable.
- Seizure acknowledge depending on the loop current in the a/b-wires.
- Backward signalling in accordance with ESPA through crossover of the a/b-wires.
- Clearback detection (release from the paging system by means of the a/b-wires) even during dialling phases.
- Release acknowledgment by means of the c-wire for releases by the system (no time monitoring due to the wide variety of paging system types).
- Entry of the central operating console of the paging system signalled by pulsed crossover of the a/b-wires or by pulses on the c-wire.

4-Wire connection—for paging systems provides the following features:

- Monitoring by means of the c/d-wires.
- Power supplied to the c-wire from TMOM by means of the d-wire and by means of dc-loop in the paging system.
- Rotary dialling and DTMF by means of the a/b-wires.
- Seizure acknowledge depending on the loop current in the a/b-wires.
- Backward signalling in accordance with ESPA through crossover of the a/b-wires or by power interruptions on the c/d-wires.
- Clearback detection (release from the paging system by means of the a/b-wires) even during dialling phases.
- Entry of the central operating console of the paging system signalled by pulsed crossover of the a/b-wires or by pulses on the c/d-wires.

6-Wire connection (similar to E&M)—for paging systems provides the following features:

- Monitoring by means of the c/d-wires.

- Signalling and dial pulsing information by means of the i-wire with respect to ground or DTMF signalling by means of a/b wires.
- Seizure acknowledge depending on the loop current in the c/d-wires.
- Backward signalling in accordance with ESPA by means of the c/d-wires.
- Release acknowledgment by means of the c-wire for release by the system.
- Entry of the central operating console of the paging system signalled by pulses on the c/d-wires.

Dictation equipment (DE)

3-Wire connection

- Option for operating and idle current on the c-wire. The signalling method on the c-wire depends on the dictation equipment used (idle current with interrupt or single pulse).
- Monitoring by means of the c-wire (changing tape cartridges should not produce a line alarm).
- Power is supplied to the c-wire by the dictation equipment.
- Signalling, dialling information by means of the a/b-wires.
- Earth potential by means of low impedance on the c-wire before seizure by means of loop on the a/b-wires.
- Seizure acknowledge:
 - In idle current mode: Depending on the loop current in the a/b-wires.
 - In operating current mode: No dependencies.
- Release acknowledgment by means of the c-wire for releases by the system.

Public address system (ELA)

4-Wire connection

- Monitoring by means of c/d-wires.
- Power supplied to the c-wire from TMOM by means of the d-wire and by means of dc-loop in the dictation equipment.
- Public address system is activated by means of the p-wire after seizure.

Announcement equipment (ANSE)

6-Wire connection

- Monitoring by means of the c/d-wires.
- Ability to indicate synchronization pulses for beginning of texts or for shutting down the equipment following multiple text repetitions by means of c/d wires.
- Announcement equipment is activated by means of the p-wire after seizure.

Entrance telephone (TE)

4-Wire connection

- Monitoring by means of the c/d-wires.
- Door speaker is activated by means of the j-wire after seizure.
- Door opener function by means of the p-wire.

Night watchman service (NWS)

3-Wire connection

- Monitoring by means of the c-wire.
- Power supplied to the c-wire from the NWS.

- Rotary dialling and DTMF by means of the a/b-wires.
Earth potential by means of low impedance on the c-wire before seizure by means of loop on the a/b-wires.
- Seizure acknowledge depending on the loop current in the a/b-wires.
- Release acknowledgment by means of the c-wire for releases by the system.

Loop transformer for simplified tie-line traffic (QV)

2-Wire connection

- Rotary dialling and DTMF by means of the a/b-wires.
- Seizure acknowledge depending on the current in the a/b-wires.
- Clearback detection (release by the remote system) even during dialling phases.

Common Control Interface

The TMOM card common control logic consists of the following areas:

- System interface
- Microprocessor and memory
- Card testing capability

System Interface

The Hicom central processor interface function is performed by the Extended Line Card Interface Controller (ELIC). The ELIC connects directly to 2.048 Mbps HDLC highway and recognizes messages with the broadcast address as well as with the individual address assigned to the slot the TMOM2 is plugged in. The ELIC is also able to identify the slot address that the TMOM board is plugged into and can be addressed separately with this slot address.

Four 2.048 Mbps PCM highways also interface to the ELIC. These four highways contain a total of 128 time slots for each direction which are all available for the TMOM. The time slot-assignments are dynamically changed by the call processing on a per-call basis.

The OpenScape 4000 backplane contains a reset-signal that will cause a hard-reset to occur on the TMOM. When the TMOM is initially plugged into the OpenScape 4000-shelf, the card's power-on-reset circuit will also generate a hard-reset of at least 100 ms.

Electrical Conditions on the External Wires

A/b-Wires

For seizure, the a/b-wires provide a dc-loop with $< 400 \Omega$; during dialling the dc-loop is $< 150 \Omega$.

The loop current must be in the range of 14 to 60 mA.

During monitoring (idle state) the loop current must be in the range of 3.5 to 7 mA.

Possible maximum line length depending on the equipment is between 2x500 to 2x1000 Ω ; this depends on the voltage of the partner equipment or system. In case of a 3-wire connection the c-wire determine the line length because of its required low impedance.

The termination of the a/b-wires is $Z = 600 \Omega$ real.

9.2.38.2 Pin Assignments

Table 139 lists the pin assignments for the TMOM2 connector to the backplane.

IMPORTANT: The 2 ports of the TMOM board and the 4 ports of the TMOM2 board are now compatible. Ports 0 and one of the TMOM board correspond to ports 0 and 2 of the TMOM2 board. Ports 1 and 3 of the TMOM2 board are new.

Table 159: TMOM2 Board, Physical interface to the OpenScape 4000 Backplane

Signal name	Connector Pin	Signal Description	Direction
+ 5V	1-21, 1-40, 2-21, 2-40	Power supply +5 VDC	Input
- 48V	2-03	Power supply -48VDC	Input
GND	1-22, 1-28, 1-33, 1-39, 2-22, 2-23, 2-28, 2-33, 2-39	Ground return for the +5V and the -48V power supply	Input / Output
HO0 ... HO3	2-32, 2-31, 2-53, 2-52	PCM Highways	Input
HI0 ... HI3	2-38, 2-17, 2-58, 2-57	PCM Highways	Output
HDI	2-19	HDLC Highway	Output
HDO	2-13	HDLC Highways	Input
PRS	2-29	System reset	Input
BA0 ... BA5	2-09, 2-30, 2-34 2-35, 2-18, 2-14	Shelf address identifier	Input
FBPE	2-46	Flash boot programming enable signal	Input
FMB	2-37	Clock synchronizing signal	Input
CKA	2-15	System clock	Input
CLS	2-16	Clock select	Input
TOUT	2-45	Self-test result output	Output
TRST	2-47	Boundary scan: Test reset	Input
TCK	2-48	Boundary scan: Test clock	Input

Signal name	Connector Pin	Signal Description	Direction
TMS	2-49	Boundary scan: Test mode select	Input
TDI	2-50	Boundary scan: Test data input	Input
TDO	2-51	Boundary scan: Test data output	Output

9.2.39 TMSFP

The trunk module single frequency pulse (TMSFP) board has eight trunk circuits for inband voice frequency signaling. The interface is 4-wire, two wires for transmitting and two for receiving voice or signaling.



CAUTION: For lightning protection see [Section 2.3, "Lightning Protection"](#).

The speech path is disconnected (split) while signaling tones are being sent or received.

The signaling frequency is 2600 Hz. The 2600 Hz Signal transmitter and receiver are on board for all eight trunks.

Additional signaling by MFC, MFP1 or MFP2 are handled by registers outside this trunk and may be regarded as speech by the hardware of this trunk.

9.2.39.1 Board Variants

- Q2147-X for China
- Q2147-X300 GUS multipurpose (CIS)
- Q2147-X400 GUS (CIS) for HARRIS exchanges

9.2.39.2 LED and Key Indications

The front panel of the TMSFP board has eight LEDs and two keys.

The eight LEDs show the states of the eight trunks devices as follows:

- Off = idle
- On = busy

The busy status of each circuit is indicated by a separate LED as follows:

- The first key selects the circuit
- The second key locks the circuit

9.2.39.3 Loadware Variants

- PZGTSFP0 (China - CSN1/Railway)

- PZGTSFP1 (GUS - 2600Hz LONIIS, 2100 Hz OB, 1200/1600Hz ADASE)
- PZGTSFP2 (GUS - 2600Hz LONIIS, 2100 Hz OB, 1600+2100+2600Hz Railway)
- PZGTSFP3 (GUS - 2600Hz LONIIS, 2100Hz OB, 600/750Hz ADASE)

9.2.39.4 DIP-FIX Switches

For the following variants, the DIP-FIX switches must be left in the delivery status, that is, switches are open:

- Q2147-X

For the TMSFP Q2147-X300-2 variant, set the DIP-FIX switches as shown in [Table 140](#).

IMPORTANT: You must set the switches before plugging the board into the shelf.

Table 160: TMSFP Board DIP-FIX Settings for Variant Q2147-X300

DIP-FIX Switches				Standard Signalling Variants		
8-7	6-5	4-3	2-1			
Off	On	On	On	GUS4	2600 HZ	LONIIS
Off	On	On	Off	GUS502	1200/1600 HZ	ADASE
Off	On	Off	On	GUS501	1200/1600 HZ	ADASE
Off	On	Off	Off	GUS6	2100 HZ	LB
Off	Off	On	On	GUS7	600+750 HZ	ADASE
Off	Off	On	Off	GUS81	1600 HZ	Railway
Off	Off	Off	On	GUS82	2100 HZ	Railway
Off	Off	Off	Off	PMTS test only (factory setting)		
On = latched = closed						
Off = unlatched = open						

For the TMSFP Q2147-X400-1 variant, set the DIP-FIX switches as shown in [Table 141](#).

IMPORTANT: You must set the switches before plugging the board into the shelf.

Table 161: TMSFP Board DIP-FIX Settings for Variant Q2147-X400

DIP-FIX Switches				Variants for HARRIS exchanges (+ 425 Hz)		
8-7	6-5	4-3	2-1			
Off	On	On	On	GUS41	2600 HZ	HARRIS
Off	On	On	Off	GUS512	1200/1600 HZ	
Off	On	Off	On	GUS511	1200/1600 HZ	
Off	On	Off	Off	GUS61	2100 HZ	LB
Off	Off	On	On	GUS71	600+750 HZ	
Off	Off	On	Off	GUS811	1600 HZ	
Off	Off	Off	On	GUS821	2100 HZ	
Off	Off	Off	Off	PMTS test only (factory setting)		
On = latched = closed						
Off = unlatched = open						

Transmission Parameters

DTMF transmission levels for GUS5xx (CIS):

GUS501, GUS511: switchable Standard = -4,4 dBm0, optional = -8,8 dBm0
 GUS502, GUS512: switchable Standard = -4,4 dBm0, optional = 0 dBm0

Impedance: 600 Ω for active state and for idle state. The same impedance is used for tone signaling.

Table 162: Transmission Parameters

AMO SICOFI Index	Relative Levels [dBr]		Maximum Line Attenuation [dB]	Remarks
	DA	AD		
0	-4,0	-4,0	0	New standard levels
1	-3,5	-3,5	0	Old standard levels
2	-3,0	-4,0	0,5	Line attenuation related to the old standard levels
3	-2,5	-4,5	1,0	
4	-2,0	-5,0	1,5	
5	-1,5	-5,5	2,0	
6	-1,0	-6,0	2,5	
7	0	-7,0	3,5	

AMO SICOFI Index	Relative Levels [dBr]		Maximum Line Attenuation [dB]	Remarks
	DA	AD		
DA = Digital switch to Analog line AD = Analog line to Digital switch				

9.2.40 VCM Voice Compression

The voice compression (VCM) board allows up to four calls for every channel to happen simultaneously. The integrated voice compression is transmitted at 16 Kbps. Compressed voice connections can be switched to various destinations without decompressing and without loss of transmission quality.



CAUTION: For lightning protection see [Section 2.3, "Lightning Protection"](#).

In networks with S2M nailed connections, each S2 highway offers up to 30 B-channels, all of which can be used for compressed connections. At a compression factor of 1:4, this offers a theoretical maximum of 120 connections. In practise, up to 112 connections are possible.

Each VCM board (Q2235-X) can be used for compressing and decompressing voice connections on up to 15 channels. This means that eight VCM boards are necessary to obtain the maximum number of compressed connections on one S2 highway.

The VCM board emulates the DIUN2 board on the OpenScape 4000 side.

This board is assigned a separate trunk group for compressed voice connections. All connections routed through this board are compressed to 16 Kbps.

Since the VCM board emulates the DIUN2 board, an appropriate signalling channel (D-channel) is also set up as the first modulated channel subset in a 64 Kbps timeslot. The signalling information is transmitted with the 16 Kbps HDLC protocol.

On the network side, the compressed connections are routed to a real DIUN2 board or STMD2 board by means of a nailed connection, where they are transparently switched through to the appropriate S2 or S0 highway channel.

- A VCM board has only one D-channel and can only be connected to one DIUN2 board at a time. It is possible for several VCM boards to connect to one DIUN2 at the same time (DIUN2 = > max. 16 VCM15 boards;
- When the compressed trunk group is configured (nailed connection), you will be cautioned to ensure the correct symmetry of the configuration. A symmetrical configuration for two system nodes simply means that the configured VCM B-channels in one node must lead to a corresponding number of switchable VCM B-channels in the partner node.

IMPORTANT: The correct symmetry is the responsibility of the system administrator!

- Any B-channels of the DIUN2 board can be assigned. The sequence in which they are seized is not important. The VCM B-channels must be assigned to the channels of the DIUN2 board in sequence.
- The VCM B-channels can also be individually enabled and disabled. You must ensure that the subset or quarter-channel used for signalling is disabled last (or, conversely, enabled first). The B-channels must always be enabled or disabled symmetrically, that is in the home node AND in the partner node.
- The VCM board does not require loadware parameterization.
- The downloading parameter sets of the DIUN2 are not affected by the voice compression utility.

IMPORTANT: The VCM board must not be defined as a reference clock supplier.

- Partial failures of the VCM cannot be signalled to the partner node. Channel-specific dependability blocking of the VCM B-channels would lead to an asymmetrical situation, that is, outgoing voice compression calls from the partner node could lead to blocked B-channels in the home node. For this reason, dependability always reacts to defective VCM channels by putting the entire board out of service. The loss of the signalling channel can be detected by the partner node, which can then react accordingly and block its own appropriate VCM board.
- The possibility of outgoing connections leading to blocked B-channels in a partner node cannot be avoided elegantly. For this reason, you must always deactivate the entire S0 or S2 highway before reconfiguring the channel compression ratio.
- Routing is carried out with the LCR system, exclusively.
- In the LDAT AMO, the LCR route elements concerned must be assigned the attribute >COMPRESSED<.

A threshold value for the maximum number of compression/decompression cycles must also be assigned.
- The VCM circuit data must also contain the >COMPRESSED< attribute (necessary for incoming seizures)
- The LCOSV (LCR class of service for voice connections) of a station line defines whether or not a compressed connection is permitted (appropriate attribute is defined with the LAUTH parameter of the AMO).
- For call data recording purposes, no special compressed connection attribute is necessary. The current CDR functionality is sufficient for compressed voice connections (e.g.: ZONE / CARRIER).
- Parallel seizure of the S2M / S0 for non-compressed connections such as data (64 Kbps), analog fax, modem or 64 Kbps voice connections (for higher-grade transmissions) is possible, due to the exclusive assignment of the B-channels for compressed or non-compressed connections.
- DIUN2 / STMD2 / VCM boards for compressed connections must not occupy an LTU quarter or LTU half in which a SIUX/SIUX2 is configured.
- Echo compensation is not necessary with voice compression, since the G.728 method used has extremely short processing periods (1-2 msec.). In networks which require echo compensation for other reasons, this must take place on the network side of the compressed connections, that is voice compression must not take place between two echo compensation units.
- Route optimization can be deactivated for voice compression connections per system.

9.2.40.1 Switching Boards and Circuits

The VCM board and circuits are switched with the BSSU and DSSU AMOs.

With partner board and circuits, the BSSU and DSSU AMOs detect soft-blocking (or activation) of the nailed connections of a partner board and carry out a soft block or activation of the appropriate VCM boards or circuits.

In the case of a hard blocking of a partner board or circuit, the appropriate VCM boards or circuits are also blocked by dependability.

9.2.40.2 Activating and Deactivating Voice Compression

On the system side, a VCM-B15 offers 15 full B-channels (voice only); on the network side, however, up to 4 channels are grouped per nailed connection (voice and data). This reduces the capacity for data transmission.

In some circumstances, it may be necessary to decrease the ratio or compression factor of VCM B-channels to S0/S2 B-channels to increase the data transmission capacity. This ratio can be increased at a later time, as the demand for voice channels increases. The nailed connections for voice compression connections must be switched symmetrically in both nodes.

IMPORTANT: The nailed connections for voice compression connections must be switched symmetrically in both nodes.

9.2.40.3 Configuring the VCM Board Using AMOs

To configure the VCM board use the following AMOs:

• DIMSU	Assign memory for VCM
• FEASU	Enable VC feature
• COT	SPCM for VCM circuits / VCMN fir for circuits which are also to carry data, or if external voice compression units are connected.
• TDCSU	COTNO / COTX / DEV
• LDAT	LATTR=VOICO / VCCYC=<number> (that is, number of times a call can be compressed)
• VOICO	Assign PEN / VCM / B-channels
• ZAND	ROLCKVCM=Y deactivates route optimization for voice compression

9.2.40.4 Configuring the Shelves

[Table 143](#) lists the configuration of the VCM boards with a DIUS2 board on first shelf.

.All the B-channels of a DIUN2 are to be used for compressed connections if required.

- Eight VCM boards are required for every DIUN2 circuit (30 B-channels) = 16 VCMs
- DIUN2 / 60 TSLs
- VCM / 19 TSLs 4 Nailed Connection timeslots + 15 B-channel timeslots

Table 163: Shelf Configuration of VCM Boards with DIUS2 Board On Shelf One

1	2	3	4	5	6	7	8	9	10	11	12	13	14	15	16
D I U S 2				V C M	V C M	V C M		V C M	V C M	V C M		V C M	V C M	V C M	

Table 144 lists the configuration of the VCM boards on the second shelf.

The board can be installed in any free slot in an LTU half. Remember the maximum number of 128 timeslots for every LTU half.

Table 164: Shelf Configuration of VCM Boards with DIUS2 Board on Shelf Two

1	2	3	4	5	6	7	8	9	10	11	12	13	14	15	16
V C M	V C M	V C M		V C M	V C M	V C M		V C M							

Table 145 lists the configuration of the VCM boards with a STMD board on shelf one.

All the B-channels of an STMD2 board are to be used for compressed connections, if required

- One VCM required for every STMD2 circuit (2 B-channels)
- STMD2 / 16 TSLs
- VCM (under equipped) / 9 TSLs

Table 165: Shelf Configuration of VCM Boards with STMD Board On Shelf One

1	2	3	4	5	6	7	8	9	10	11	12	13	14	15	16
S T M D	V C M	V C M	V C M	V C M	V C M	V C M	V C M	V C M							

Figure 125 shows a functional diagram of the VCM board.

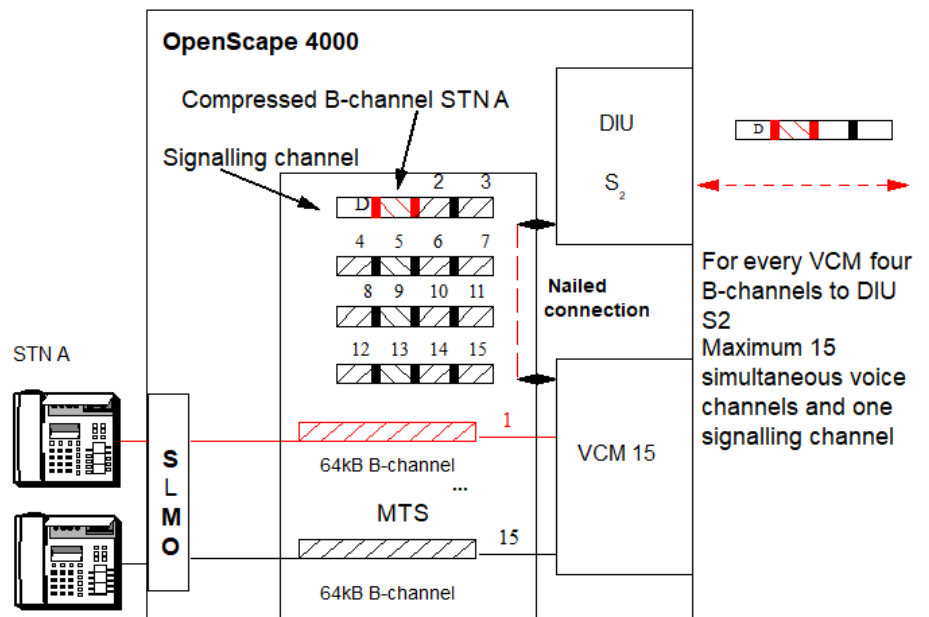

Figure 156: VCM Overview

9.2.40.5 Compression, Outgoing

Outgoing seizures of compressed routes are always handled by the VCM board. This is achieved by configuring the VCM trunk group appropriately. On the OpenScape 4000 side, the VCM emulates a normal DIUN2.

The OpenScape 4000 system treats such connections as normal outgoing connections. One of the 15 available VCM channels is seized for connection setup by call processing. This channel is selected with the aid of the route discrimination and device search components. In the VCM board, the connection is compressed and the appropriate timeslot subsets of the physical B-channel (nailed connection) are selected for D-channel and compressed B-channel signalling to the correct DIUN2 board. The DIUN2 board simply switches the timeslots received by the VCM through to the appropriate timeslots of the S2 highway (that is, transparently). The assignment of nailed connection timeslots to S2 timeslots can be configured with AMO commands.

9.2.40.6 Decompression, Incoming

Incoming compressed connections are transparently switched through to the nailed connection of a VCM by the DIUN2. The VCM board receives the compressed connection, decompresses it and selects an appropriate 64 Kbps timeslot on the Hicom side for transmission to the switching network. The VCM emulates a normal DIUN2 board on the system side, and the connection is accordingly switched through to the station line by the call processing system.

9.2.40.7 Transit Connections

Compressed -> decompressed

Refer to [Section 8.2.39.6, "Decompression, Incoming"](#).

Compressed -> compressed

Incoming compressed connections are transparently switched through to the nailed connection of a VCM board. By default, the connection are decompressed for call processing on the system side. In the case of transit connections, that is, from one VCM to another, the call processing system sends an appropriate message to the VCM boards (both boards), whereupon the decompression is deactivated, and the compressed connection transparently switched through the system. As soon as the B-channel is established between the two boards, the entire connection path is monitored using inband signalling. This allows the VCM boards to determine whether the transit connection is still open or not.

The inband signalling is carried out at periodic intervals throughout the duration of the compressed connection. If the B-channel status changes during the call due to activated features, for example, through consultation hold with subsequent call transfer, the decompression is deactivated, if the inband signalling system detects that the call has been transferred to a station line circuit.

Inband signalling is only carried out internally between VCM boards in a OpenScape 4000 system. The signalling information is transmitted using redundant bits, that is, bits not used for voice signalling. Inband signalling is only used for transit connections, that is, from one VCM to another.

In the transit node, the connection is switched through transparently, that is, in compressed form, using a 64 Kbps timeslot. The timeslot carries only one connection, which means only one of every four channels is used. The other subsets remain unused, or are used for the periodic inband signalling in the B-channel between the two VCM boards.

[Figure 126](#) shows an example of a transit connection.

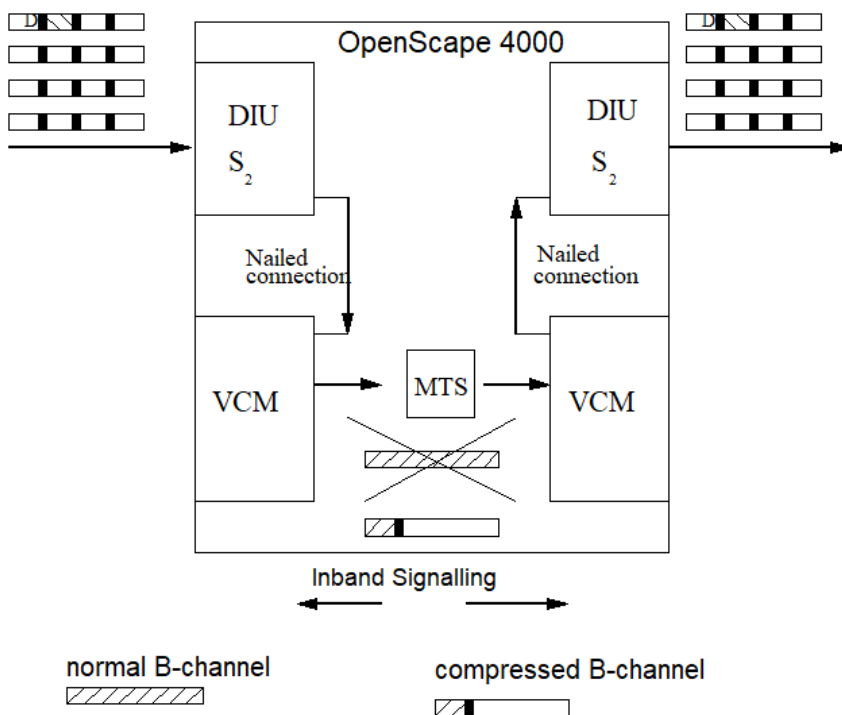

Figure 157: Transit Connection Example

9.2.40.8 Mixed Mode Operation, Voice and Data

Figure 127 shows an example of mixed mode operation for voice and data.

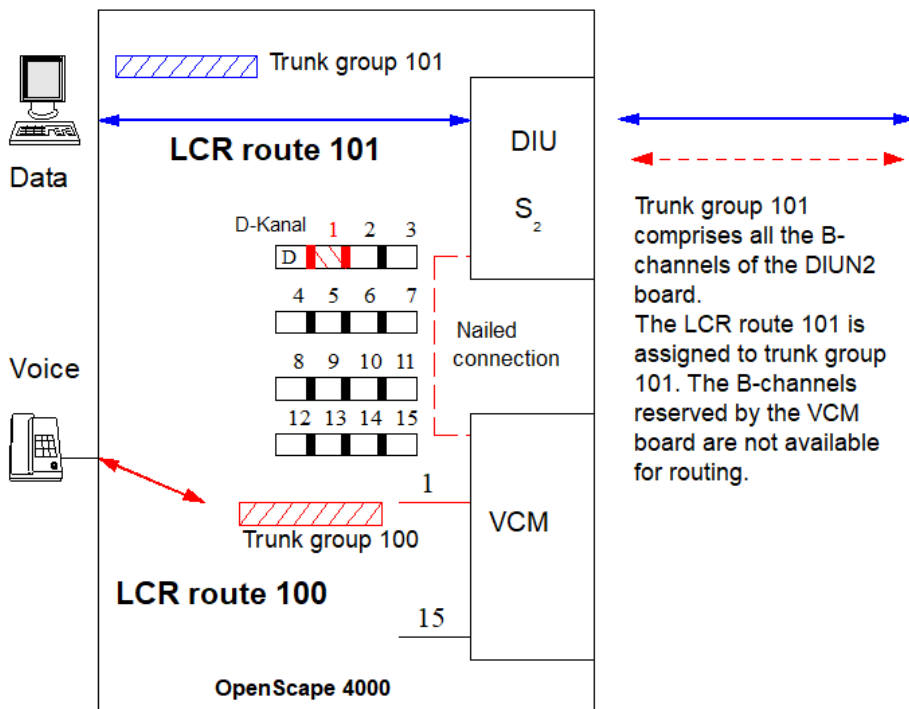

Figure 158: Mixed Mode Operation, Voice and Data

DIUN2 B-channel access can be controlled by deactivating and reactivating the individual B-channels of a nailed connection, depending on the traffic volume.

IMPORTANT: Do not forget the B-channels of the partner system.

9.2.40.9 Administering More Data Channels or More Voice Channels

If the demand for data channels increases at certain times of the day, for example, at night, the amount of available B-channels for data transmissions can be increased by deactivating the appropriate voice compression nailed connections. This significantly reduces the number of available voice channels.

If more voice channels are required at a later time, the nailed connections carrying these channels must be explicitly re-activated again.

No voice compression for specified users

Certain station line types, for example, analog fax or modem lines, are not automatically recognized by call processing as data lines, and are therefore not automatically disabled for voice compression.

These lines must be expressly protected from voice compression with the aid of administration and maintenance commands, e.g. using the standard LCR control mechanisms.

9.3 Power FRUs

9.3.1 AC-Powered, Non-Redundant System (with L80XF Shelf)

The power FRUs on an AC-powered, non-redundant OpenScape 4000 system are:

- One AC-to-DC shelf power supply unit (ACPCI) on the CSPCI shelf
- One AC-to-DC shelf power supply unit (LPC80) on the L80XF shelf
- One DC-to-DC shelf power supply unit (PSUP) on the L80XF shelf

IMPORTANT: A UACD powerbox can also be used as a battery backup. If a Powerbox is used as a battery backup, a DC-to-DC power supply is required.

9.3.2 DC-Powered, Non-Redundant System (with L80XF Shelf)

The power FRUs on a DC-powered, non-redundant OpenScape 4000 system are:

- One DC-to-DC shelf power supply unit (DCPCI) on the CSPCI shelf
- One DC-to-DC shelf power supply unit (PSUP) on the L80XF shelf

9.3.3 AC-Powered, Redundant System (with LTUW Shelf)

The power FRUs on an AC-powered redundant OpenScape 4000 system are:

- Two AC-to-DC shelf power supply units (PSUC) on the CSPCI shelf
- Two UACD power boxes

IMPORTANT: Two DC-to-DC shelf power supply units (PSUP) on the LTUW shelf. If a Powerbox is used as a battery backup, a DC-to-DC power supply is necessary.

9.3.4 DC-Powered, Redundant System (with LTUW Shelf)

The power FRUs on a DC-powered, redundant OpenScape 4000 system are:

- Two DC-to-DC shelf power supply units (PSUP) on the CSPCI shelf
- Two DC-to-DC shelf power supply units (PSUP) on the LTUW shelf

9.3.5 ACPCI/DCPCI

The ACPCI/DCPCI power supply units (see [Figure 129](#)) are used on the new CSPCI shelf and Survivability Server (see [Section 4.8, "Survivability Server"](#)). The two power supply units vary only in input power. The output voltages and the mechanical design are identical.

IMPORTANT: The factory setting for the CSPCI shelf's power supply coding is always set to ACPCI. To use DC power supplies (DCPCI), you must change the coding according to [Figure 128](#). The power supply is hot pluggable. Don't put the power supply in the CSPCI shelf violent.

**Front
Duplex configuration**

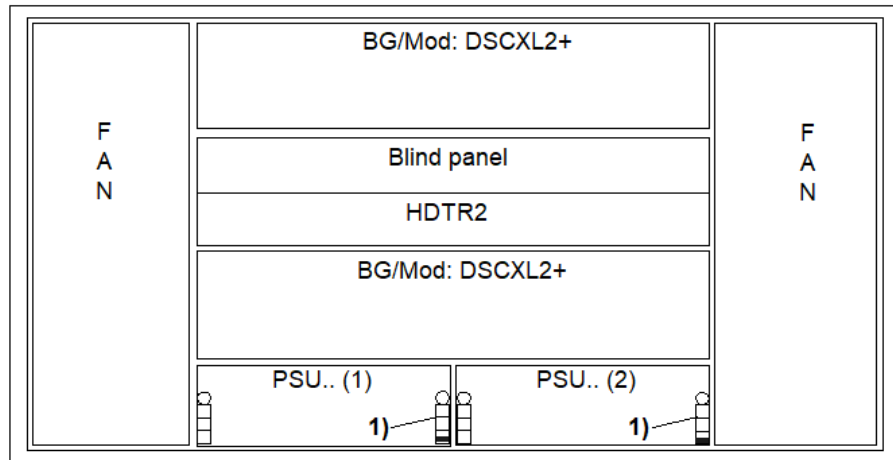

1) Coding of power supplies:

- AC power supply	1)		Chamber F: empty Chamber E: empty Chamber D: Position 1
- DC power supply	1)		Chamber F: empty Chamber E: empty Chamber D: Position 3

Figure 159: Coding for power supply configurations ACPCI/DCPCI

The ACPCI converts AC power to DC. The AC input voltage is 90-264 VAC from the utility outlet that provides power to the system (nominal input voltage 110/230 VAC). The nominal input frequency is 50/60 Hz (tolerance: 47-63 Hz).

The mains input power cable is not directly connected to the power supply unit but is plugged in at the back of the CSPCI shelf (refer to [Section 7.3.5.1, "ACPCI/DCPCI Input Power Connectors"](#)). The mains input power is fed into the power supply unit by means of the backplane. The AC power supply cable is fed through a slot in the front panel of the MCM board.

For the DCPCI, only 48 VDC (tolerance: 36-72 VDC) is directly connected to the back of the backplane.

The individual output voltages are: +3.3 V (33 A), + 5 V (33 A) and +12 V (5 A).

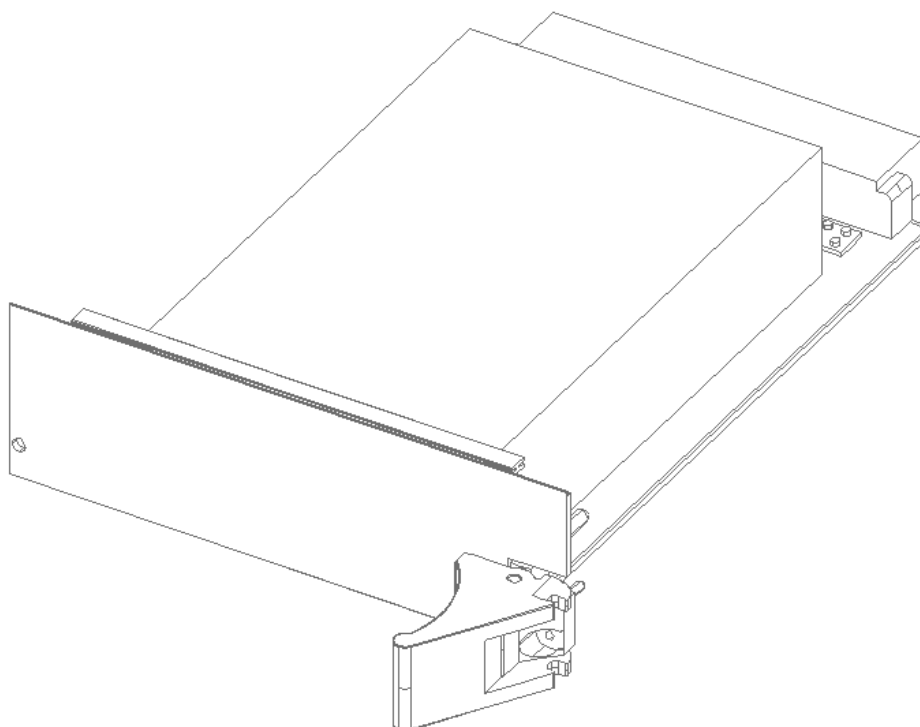

Figure 160: ACPCI/DCPCI Power Supply

9.3.5.1 ACPCI/DCPCI Input Power Connectors

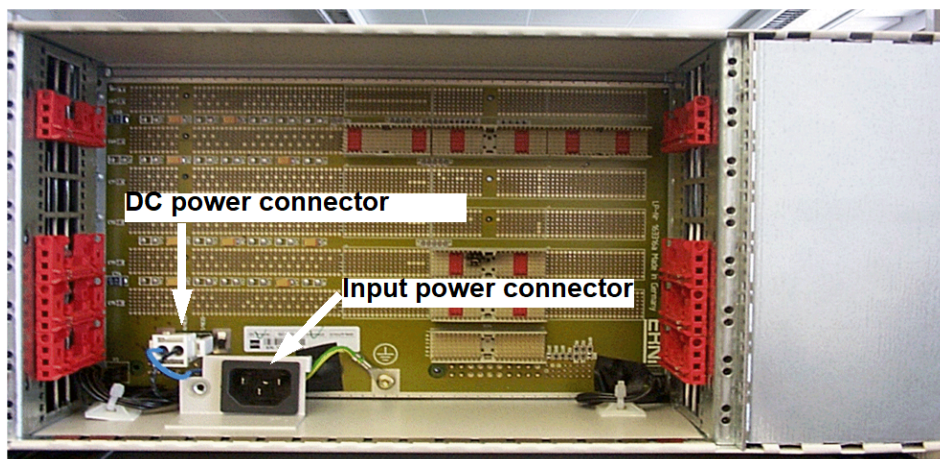

Figure 161: ACPCI/DCPCI Power Connectors

9.3.5.2 Hardware Variants

ACPCI:

Magne Tek (S30122-K7682-M1)

Cherokee (S30122-K7682-C1)

Legacy Hardware

Cable variants: 3-pin for IM: C39195-Z7001-C17 or 3-pin for NA: C39195-Z7001-C19

(IM = International Market, NA = North America)

DCPCI:

Magne Tek (S30122-K7683-M1)

Cherokee (S30122-K7683-C1)

Cable variant: S30805-H5298-X14

9.3.5.3 LED Indications

The ACPCI/DCPCI has one green LED that is lit when all output voltages are within tolerance. The LED is not lit if any DC output voltage is not within tolerance or if the input voltage is lost.

9.3.5.4 Removing the ACPCI/DCPCI

To remove the ACPCI, unfasten the two screws on each side of the power supply unit.

9.3.5.5 Replacing the ACPCI/DCPCI

To replace the ACPCI, tighten the two screws on each side of the power supply unit.

9.3.5.6 Verifying the ACPCI/DCPCI

To verify the ACPCI or DCPCI, ensure that the green LED is lit.

9.3.5.7 Input/Output Assignment

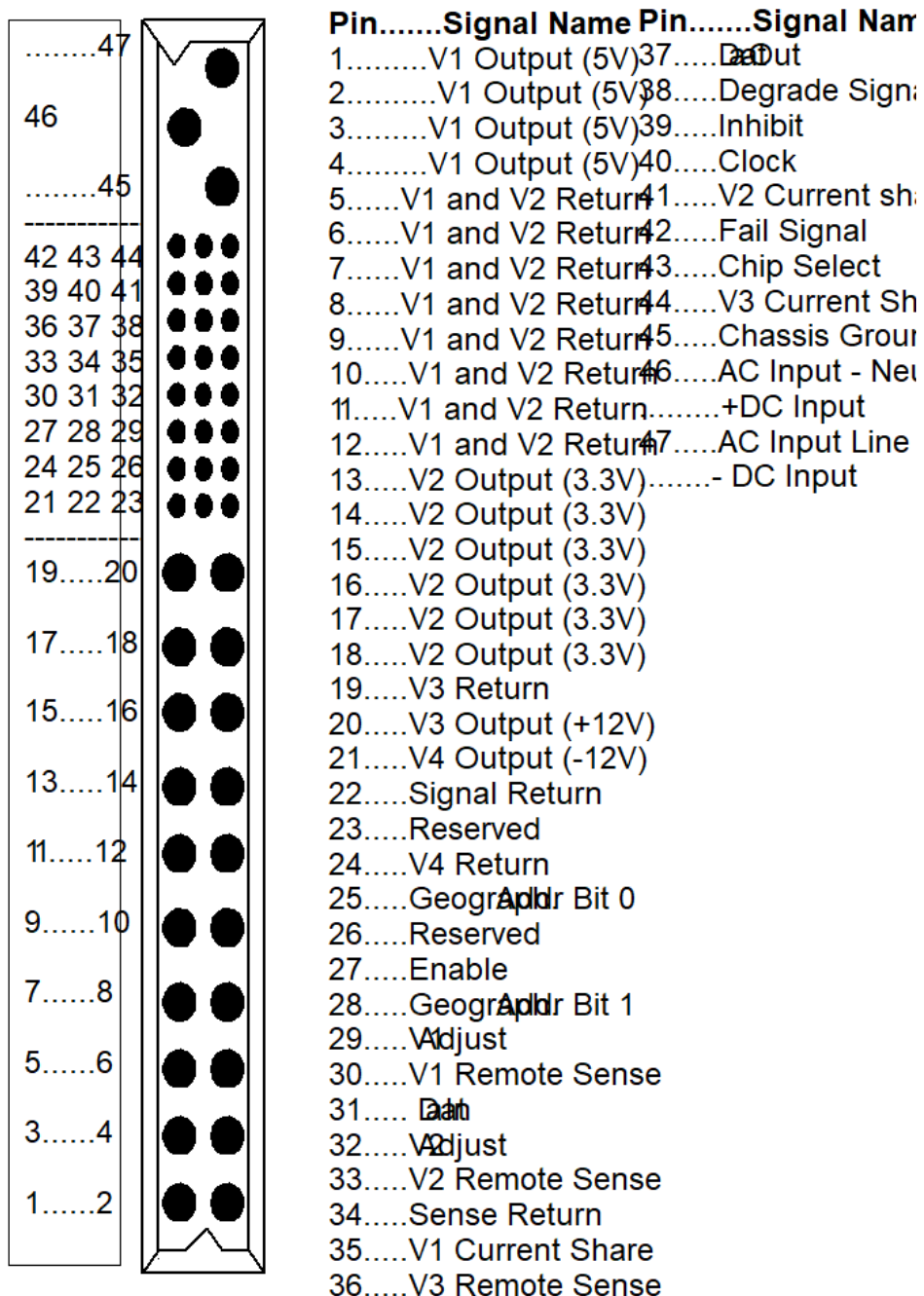

Figure 162: ACPCI Input/Output Assignment

9.3.6 LPC80

The AC-to-DC shelf power supply unit (LPC80) converts AC power to bulk DC, talk voltages. The nominal AC input voltage are 176-253 VAC (LPC80 WR Artesyn 110-230 VAC, Magnetek 110-253 VAC) from the utility outlet that provides power to the cabinet. Its output is bulk -48 VDC that it delivers to the

DC-to-DC shelf power supply and talk and ring voltages. The frequency is between 45 Hertz (Hz) and 66 Hz (LPC80 WR Artesyn 50-60 Hz).

The LPC80 occupies slot 16 on the L80XF shelf. It distributes the voltages to the shelf power supplies through backplane connectors.

LPC80 (WR = Wide Range)

9.3.6.1 LPC80 Power Connection

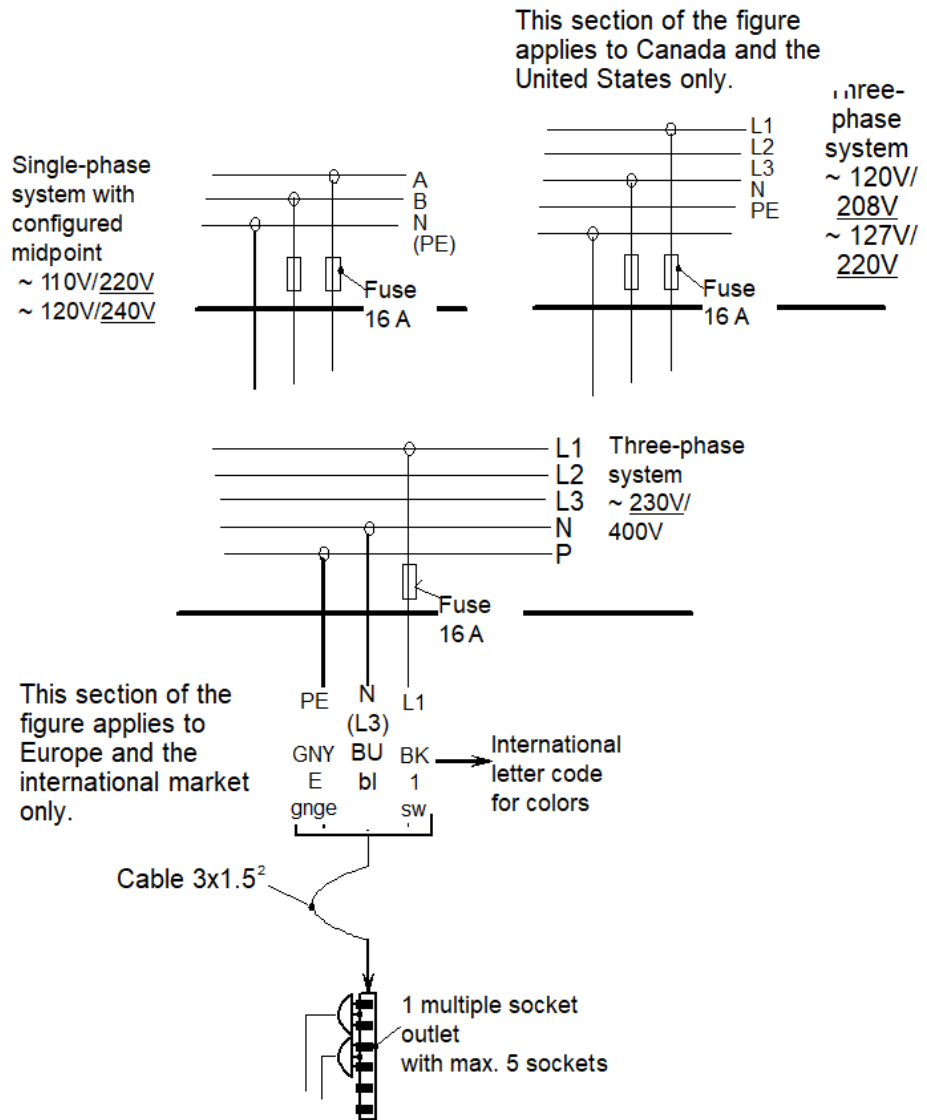

Figure 163: LPC80 Power Connection

9.3.6.2 LPC80 Power Supply Unit, Technical Data

Part Number LPC80: S30122-K7162-X (Artesyn) Part Number LPC80: S30122-K7163-X (Celestica) Part Number LPC80: S30122-K7554-X (Magnetek) Part Number LPC80 WR: S30122-K7554-A (Artesyn)

Weight: approximately 4.3 kg (9.5 lbs.)

Design: Plug-in unit for 2-slot shelf

Dimensions: D = 330mm (13 in.), W = 80mm (3.1 in.), H = 265mm (10.4 in.)

Ambient temperature: +5 #°C (41#°F) to 55 #°C (131#°F)

Cooling: Free convection

Protection class: Protection class 1, VDE 0805/IEC 435

Standards: in accordance with PN/SBCS specifications on conformance to standards and approval (F31505-G1-X-*-A5)

Input

Altering current range: 176V - 253V

Current: approximately 2.7 A (~230V)

Frequency: 45 - 66Hz

Power Pinput 535VA (~230V)

Power factor: min. 0.95

Efficiency at 100% load: min. 88%

Power supply connection: modular power cord, 3-pin

Outputs

Output power:

- max. 470W
 - LPC80, standard for CAB80DSC/DSC1 *)

	Nom. voltage	Min. voltage	Max. voltage	Limit	Rated power	Min. power	Over current range
U1 (Bulk)	54,7V	54,3V	55,1V	60V	290W	0 A	7A-7.5A
U2 (Talk)	54,7V	54,3V	55,1V	60V	180W	0,1A	4,5A-5A

- LPC80, battery charger mode: *)

	Nom. voltage	Min. voltage	Max. voltage	Limit	Rated power	Min. power	Over current range
U3	54,7V	54,3V	55,1V	60V	470W	0A	9A-10A
U3	53,5V	53V	54V	60V	470W	0A	9A-10A

Switching Operating Modes: *)

Table 166: Operating Mode Settings of the LPC80

Between standard/charger mode (on the back of the LPC80)	for - K7162-	Artesyn: neutral switch, clearly identifiable from sticker 1st option: Battery Charger 2nd option: Power Supply Peripheral Shelf: standard mode for CAB80DSC
	for - K7163-	Celestica: jumper W1, clearly identifiable from sticker ON --> connector W1 with J5 --> battery charger mode OFF --> connector W1 with J6 --> standard mode for CAB80DSC
	for K7554-	Supplier: MagneTek/Artesyn 3-pin connector behind a window on the underside of the power supply unit. (2 screws) 1. Connector in "Mode1": as used with peripheral shelves 2. Connector in "Mode2": as used with battery chargers
Between two possible voltages (in charger mode)	for - K7162-	Artesyn: jumper setting, clearly identifiable from sticker 1st option: 54.7 V (factory setting) 2nd option: 53.5 V
	for - K7163-	Celestica: jumper J9, clearly identifiable from sticker 1st option: connection between pin 3 and pin 4 from J9 --> 54.7V (factory setting) 2nd option: connection between pin 1 and pin 2 from J9 --> 53.5V
	for K7554-	Supplier: MagneTek/Artesyn Switch on the underside of the power supply unit; (voltages shown on circuit board) - Switch in left position --> 53.5V - Switch in right position --> 54.7V

Short circuit current: 1 x IN to 1.2 x IN

Output connector: by means of "H15-ERNI" connector on the backplane

Monitor: Summation signal for errors U1 to U2 (undervoltage or overvoltage) with floating relay contact (switch).

Control elements and visual indicators (front)

- Operating switch: I - O
- Operation indicator: green LED
- Modular power cord, 3-pin: power supply unit

LPC80, "ERNI H15" pin assignment (15-pin)

Slot EBP B2 016

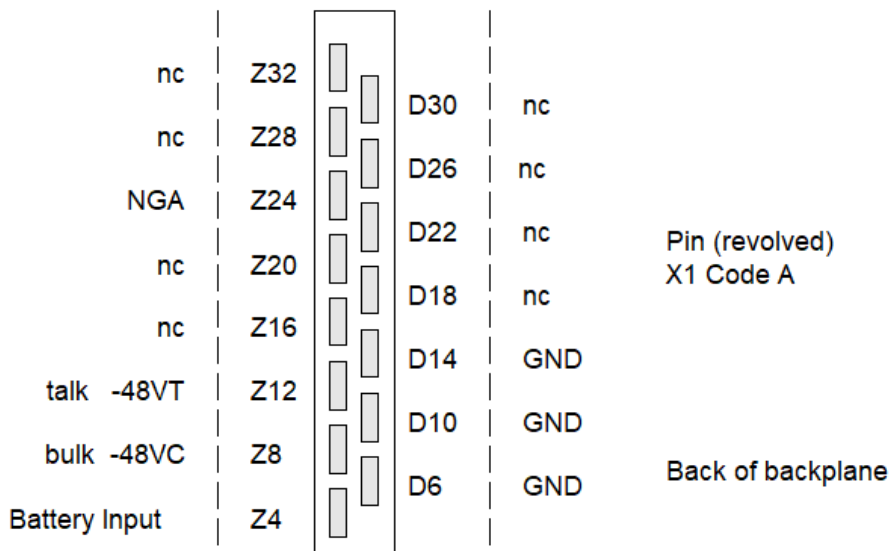

Figure 164: "ERNI H15" Pin Assignment

9.3.6.3 LPC80 LED Indications

The LPC80 has one green LED that is lit when all output voltages are within tolerance (see [Figure 134](#)). The LED is off if any DC output voltage is not within tolerance or if AC power is lost.

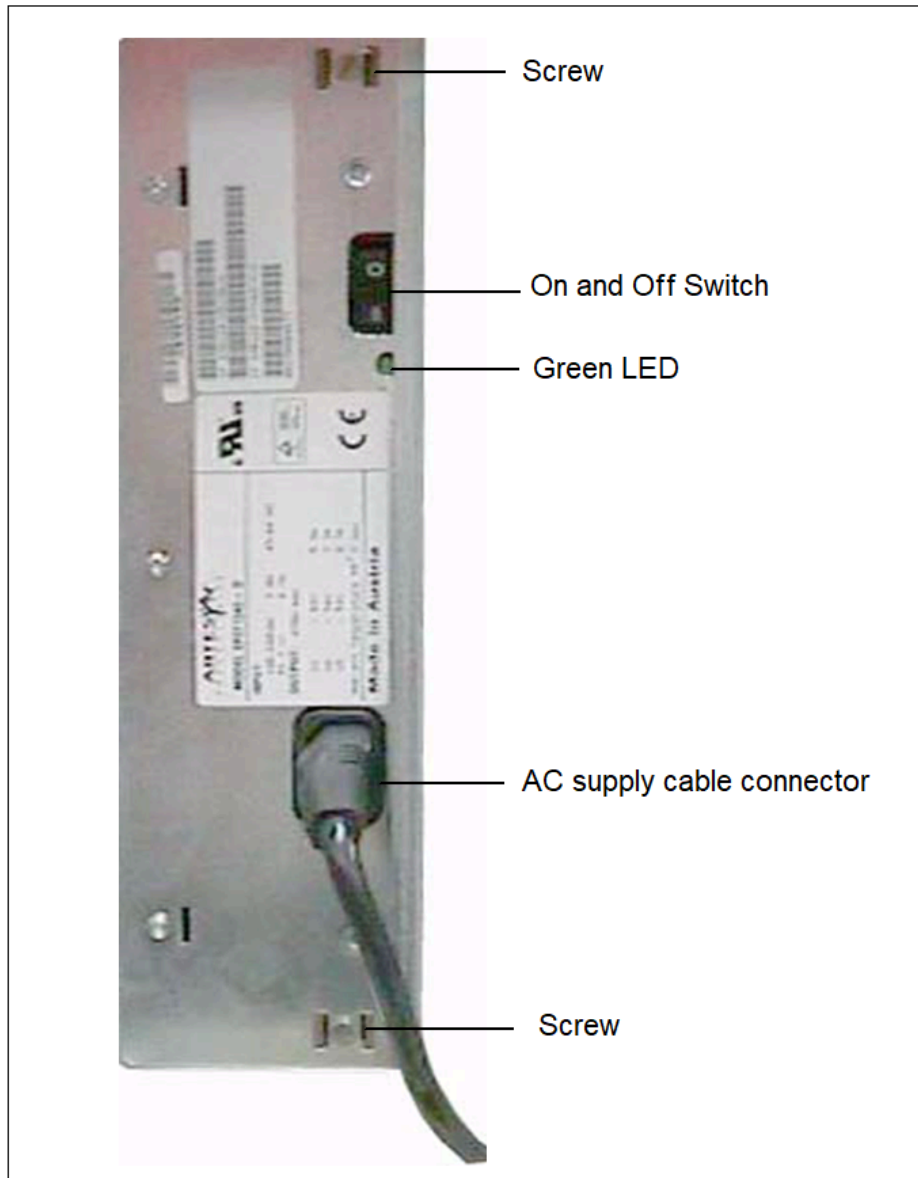



Figure 165: LPC80

9.3.6.4 LPC80 Connectors and Switches

The front of the shelf power supply has a receptacle for AC supply cable and a switch for turning the unit on or off (see [Figure 134](#)).

9.3.6.5 Removing the LPC80

 **DANGER:** Use extreme caution when you work on power supply components. Power supply voltages can be lethal. Observe all applicable electrical safety precautions for working with high

voltages. Do not wear an ESD strap when working on the backup battery.

IMPORTANT: This procedure removes the OpenScape 4000 from service when performed on the base cabinet and removes only the expansion cabinet from service when performed on the expansion cabinet.

To remove the LPC80:

- 1) Turn off the switch on the LPC80.
- 2) Disconnect the AC supply cable connector from the receptacle.
- 3) Remove the screws that secure the LPC80 to the shelf.
- 4) Remove the LPC80 from the shelf.

9.3.6.6 Replacing the LPC80

To replace the LPC80:

- 1) Ensure that the AC power supply cable is unplugged.
- 2) At the front of the shelf, slide the LPC80 into the shelf until you seat it firmly.
- 3) Secure the shelf power supply with screws to the shelf.
- 4) At the front of the LPC80, reconnect the AC supply cable connector to the LPC80 receptacle.
- 5) Plug the AC power supply cable to the wall outlet.
- 6) Turn on the switch on the LPC80.

9.3.6.7 Verifying the LPC80

To verify the operation of the LPC80, confirm that the green LED status indicator is lit.

9.3.7 PSUP

The PSUP DC-to-DC shelf power supply converts bulk -48 VDC into +5/- VDC and +/- 12 VDC and delivers the converted voltage to the boards. The PSUP receives bulk voltage from power distribution wires connected to the backplane of each shelf.

The PSUP resides in CC80F, L80XF, and LTUW shelves.

9.3.7.1 PSUP LED Indications

The PSUP has a green status LED (see [Figure 135](#)). It also has a switch for turning the unit on or off. It occupies slot 127 on the L80XF, CC80F, and LTUW shelves. It also occupies slot 16 in a redundant LTUW shelf.

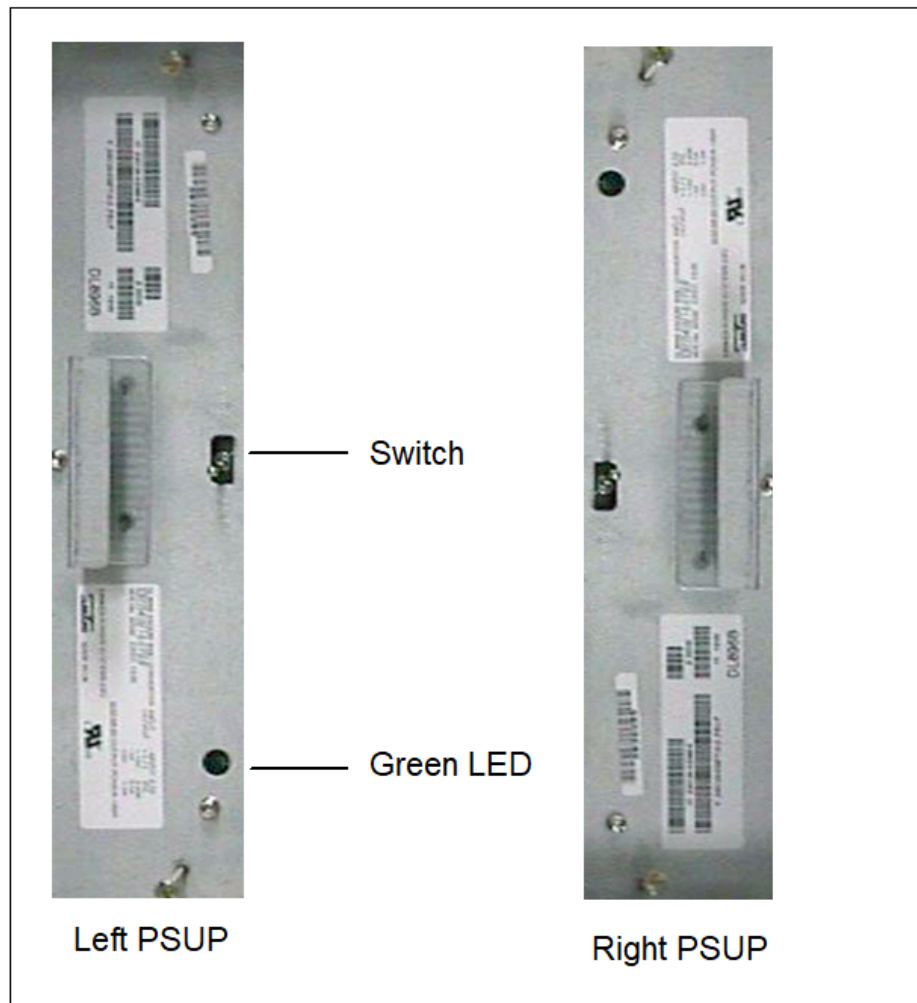

Figure 166: PSUP, Front View

Table 147 lists the LED indications of the PSUP.

Table 167: PSUP LED indications

Shelf Type	LED Color	LED Status	Indication
CC80F, L80XF, LTUW	Green	On	All output voltages are within tolerance.
		Off	One or more output voltages are below tolerance or the LTUP or LTUE power is turned off.

9.3.7.2 Removing the PSUP



Use extreme caution when you work on power supply components. Power supply voltages can be lethal. Observe all applicable electrical safety precautions for working with high voltages.

Do not wear an ESD strap when working on the backup battery.

To remove the PSUP:

- 1) Turn off the PSUP.
- 2) Loosen the screws that secure the PSUP to the shelf.
- 3) Remove the PSUP from the shelf.

9.3.7.3 Replacing the PSUP

To replace the PSUP:

- 1) Slide the PSUP into the shelf.
- 2) Tighten the screws to secure the PSUP to the shelf.
- 3) Turn on the PSUP.

9.3.7.4 Verifying the PSUP

To verify the operation of the PSUP, ensure that the green status LED is lit.

9.3.8 UACD

A unit alternating current distribution (UACD) stack consists of:

- One AC input distribution panel (ACDPX)
- One AC output distribution panel (PDPX2)
- Up to 3 line power converters (LPCs)

The UACD is stackable. One UACD supports two stacks (one on top of the other). A two-stack UACD supports a 4-stack OpenScape 4000 system with one + one redundancy.

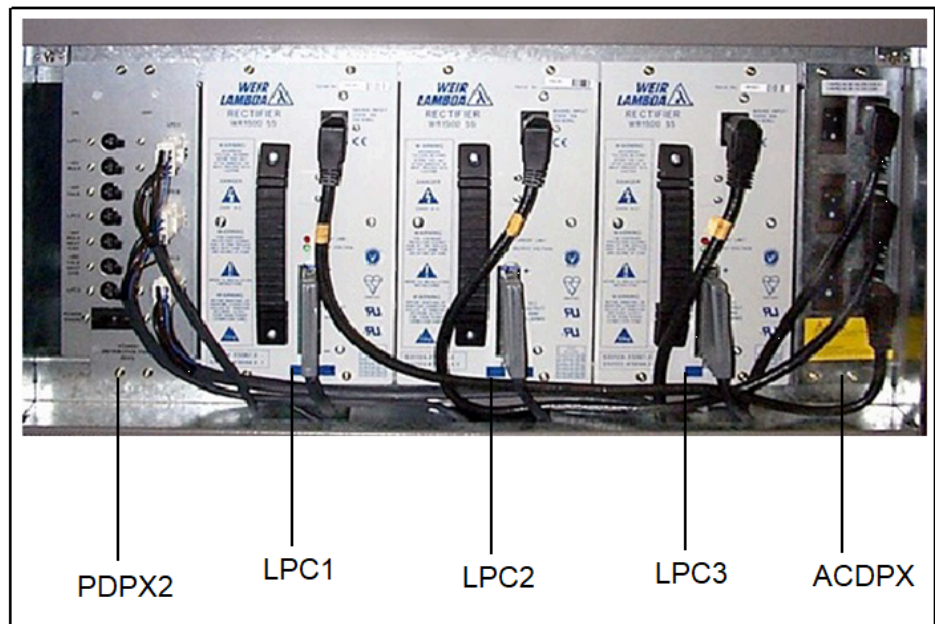

Figure 167: UACD Shelf (Front View)

9.3.8.1 ACDPX

The AC distribution panel (ACDPX) routes AC power to each of the line power converters (LPC). The NORAC kit consists of the ACDPX and a junction box.

ACDPX Connectors and Switches

The ACDPX ([Figure 137](#)) have:

- Receptacles for the AC power module input cables
- Switches to turn on or off the AC power modules individually

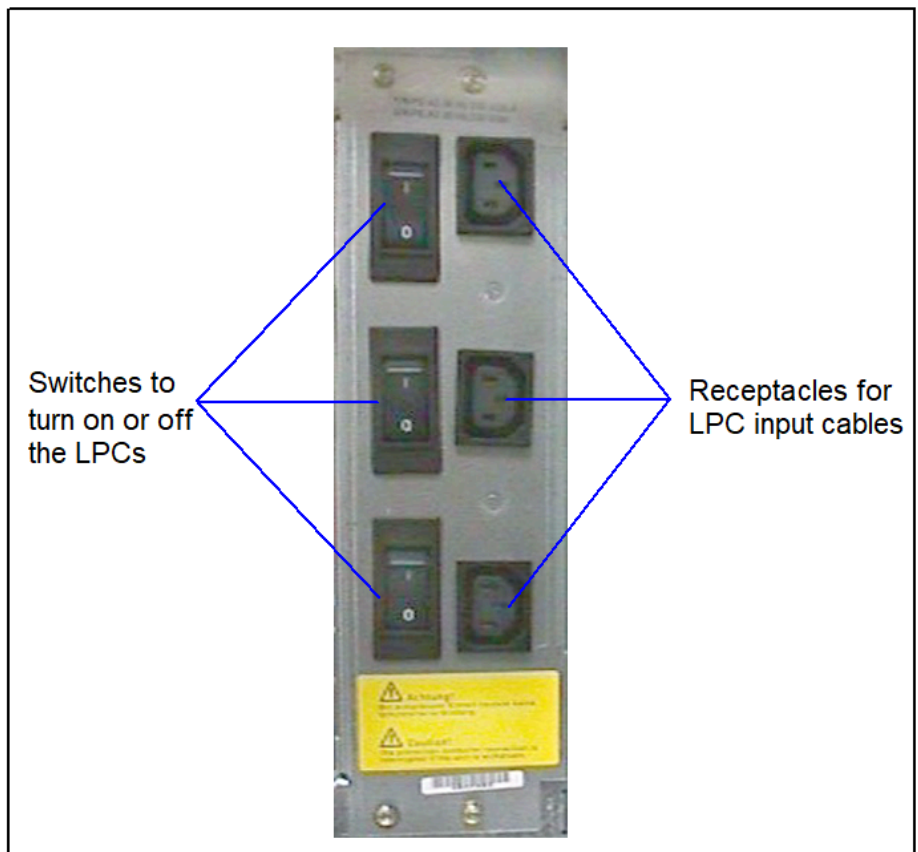

Figure 168: ACDPX, Front View

Removing the ACDPX



DANGER:

Use extreme caution when you work on power supply components. Power supply voltages can be lethal. Observe all applicable electrical safety precautions for working with high voltages.

Do not wear an ESD strap when working on the backup battery.

IMPORTANT: This procedure removes the OpenScape 4000 system from service.

To remove the ACDPX:

- 1) Turn off the respective OpenScape 4000 system stack.
- 2) Unplug the LPC input cables from the ACDPX.
- 3) Remove the top and bottom screws that secure the ACDPX to the upper and lower shelf supports (see [Figure 138](#)).
- 4) Remove the junction box.
- 5) Remove the tie wrap that secures the AC supply cable to the ACDPX.
- 6) Unplug the AC supply cable.
- 7) Remove the ACDPX.

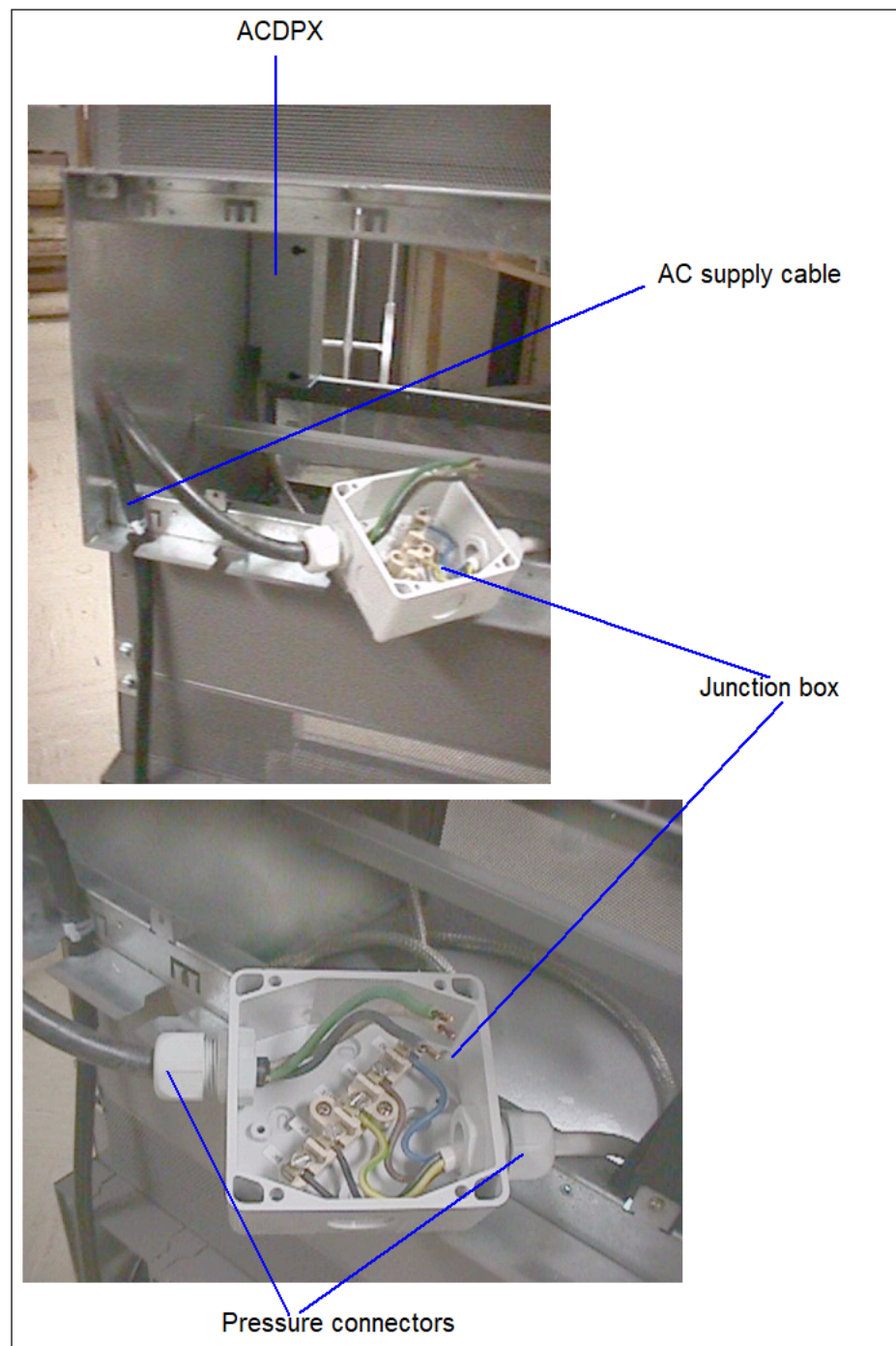

Figure 169: Removing the ACDPX from the UACD

Replacing the ACDPX

To replace the ACDPX:

- 1) Secure the AC supply cable to the cabinet frame using tie wrap.
- 2) Position the junction box inside the UACD cabinet frame using a double stick tape.
- 3) Secure the ACDPX to the upper and lower shelf supports with screws.
- 4) Plug the LPC input cables into the ACDPX.

- 5) Turn on the respective OpenScape 4000 system stack.
- 6) Plug the AC supply cable.

Verifying the ACDPX

Verify the operation of the ACDPX by ensuring that the yellow LED (healthy input) on each LPC is lit.

BAM, AC-Powered OpenScape 4000 Cabinet 1 or 2

The battery manager (BAM) controls the flow of electricity to the battery during recharging and from the battery during a power outage

BAM Connectors

The battery manager contains the following connectors:

- X1 through X9
- X6 and X7 are not used in the U.S.
- Contactor control input
- Battery power input
- The power share and battery input are not used in the U.S.

Removing the BAM



DANGER:

Use extreme caution when you work on power supply components. Power supply voltages can be lethal. Observe all applicable electrical safety precautions for working with high voltages.

Do not wear an ESD strap when working on the backup battery.

IMPORTANT: This procedure removes the OpenScape 4000 system from service when performed on cabinet 1 and removes cabinet 2 from service when performed on cabinet 2.

To remove the BAM:

- 1) Turn off cabinet 1 or cabinet 2, as applicable.
- 2) At the back of the UACD shelf, label and disconnect all the cables from the BAM.
- 3) Remove the screws that secure the BAM to the cabinet frame.
- 4) Slide the BAM partially out of the shelf until the BAM circuit board is accessible from the right (open) side of the battery manager.
- 5) First label and then remove the cables connected to the BAM circuit board.
- 6) Remove the BAM from the cabinet.

Replacing the BAM

Replace the BAM as follows:

- 1) Connect the black wire ([Figure 139](#)) to the BATTERY POWER INPUT connector at the back of the PDPX2.
- 2) Slide and secure the BAM into the UACD with screws.
- 3) Reconnect the cables to the applicable BAM circuit board receptacles.

- 4) Turn on cabinet 1 or cabinet 2, as applicable.

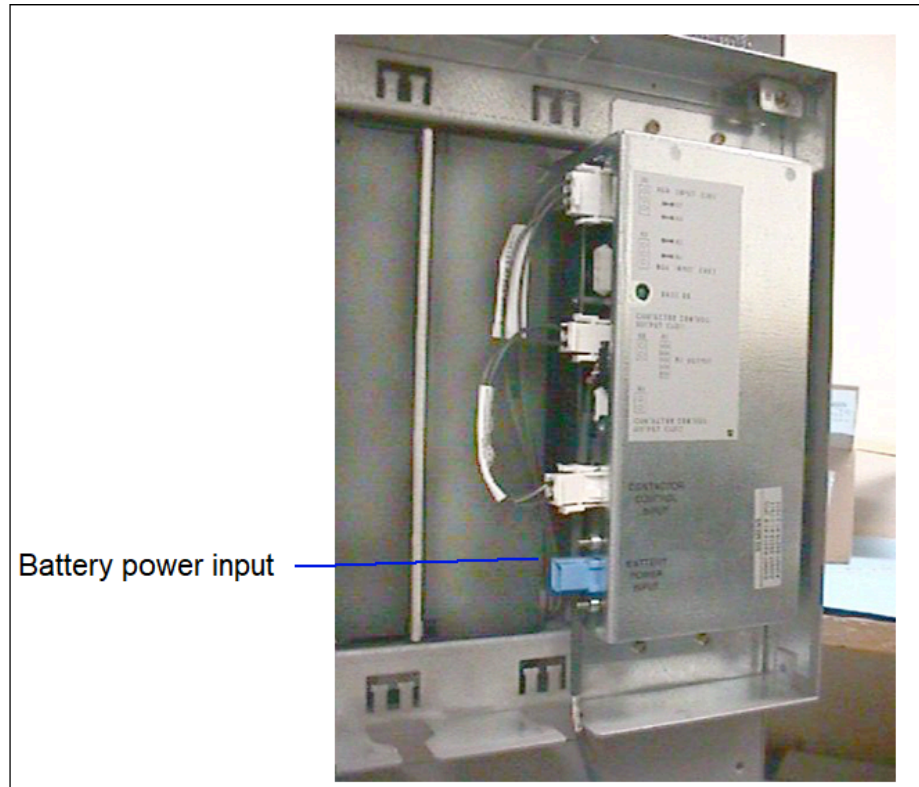

Figure 170: PDPX2, Back View

Verifying the BAM

IMPORTANT: Do not perform this procedure if the condition of the backup battery is suspected to be low or if the procedure is being performed during customer operating hours. In either case, the verification procedure must be performed quickly. A fully charged backup battery provides power for up to 2 minutes.

To verify operation of the BAM, ensure that the OpenScape 4000 system returns to normal operation.

9.3.8.2 EBCCB

IMPORTANT: The EBCCB is not used in the U.S.

The external battery connection with circuit breaker (EBCCB) provides an external connection to the power box. The external battery is connected to the battery manager through a 70-Amp circuit breaker (see [Figure 141](#)). If more than 6 LTU frames are installed in the entire system when battery management is used, then the power box is configured with two PDPXs and two EBCCBs.



Figure 171: EBCCB - Back view

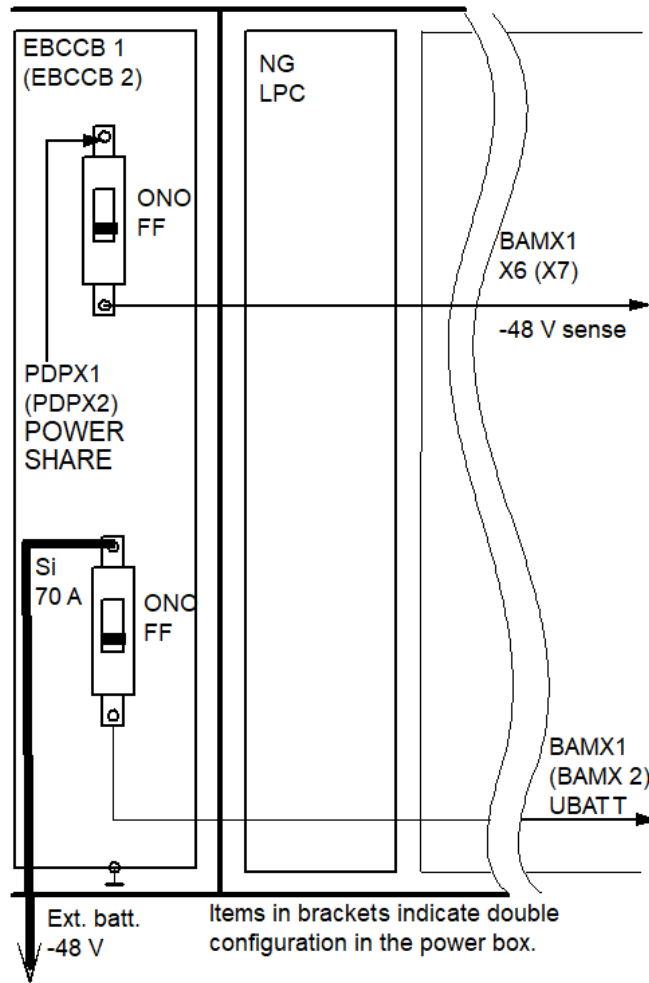

Figure 172: EBCCB, Back View

9.3.8.3 LPC

The line power converter (LPC) converts 208 VAC or 240 VAC input power to -48 VDC power (see Figure 142). Each module receives its input power from a power cord connected to the front of the ACDPX and LPC. The -48 VDC power of the LPC is routed to the PDPX2 through a cable on the front of the LPC.

LPC LED Indications

The front of the LPC has two status LEDs (see Figure 142).

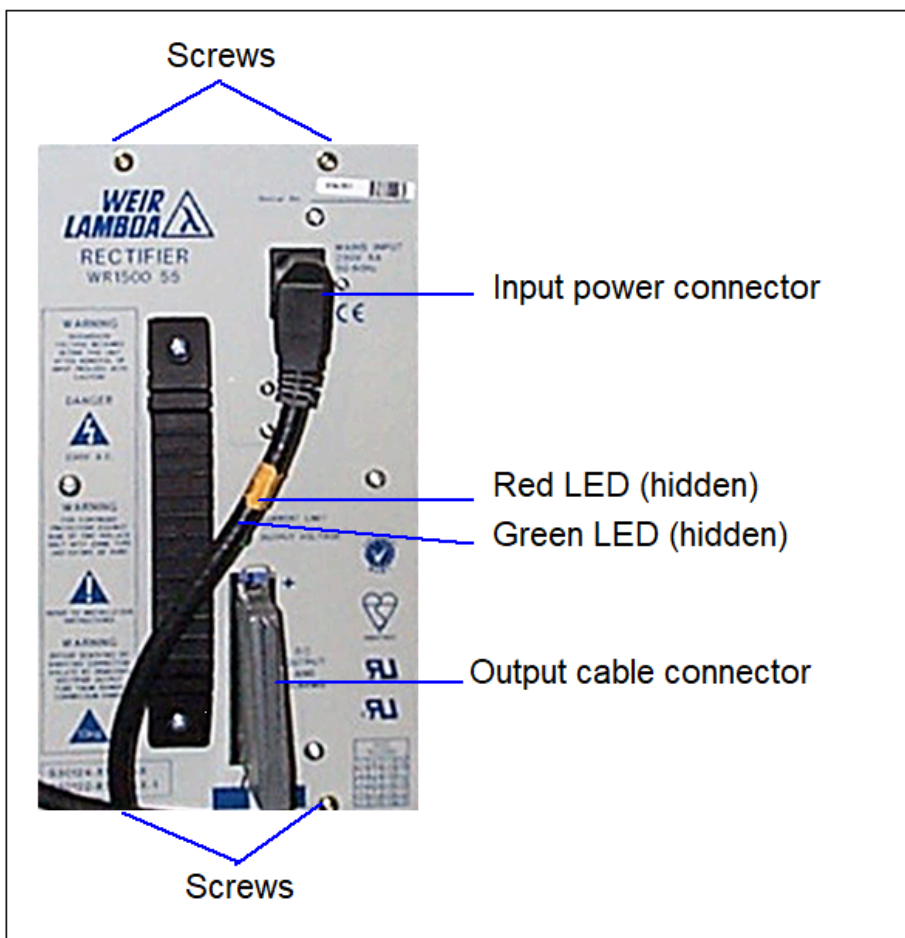

Figure 173: LPC, Front View

Table 148 lists the LED indications.

Table 168: LPC LED Indications

Name	Color	State	Indication
Overvoltage and Current Limit	Red	On	Overvoltage; overcurrent
		Off	Voltage OK; current OK
Output Healthy	Green	On	Input and output voltage are OK
		Off	Input and output malfunction

LPC Connectors

The LPCs have an input power receptacle and output power receptacle on the front panel. The module receives input power through a power cord from the ACDPX. The LPC routes output voltages and signals to a terminal block along the left side of the PDPX2 and to a connector along the right side of the PDPX2.

Removing the LPC



DANGER:

Use extreme caution when you work on power supply components. Power supply voltages can be lethal. Observe all applicable electrical safety precautions for working with high voltages.

Do not wear an ESD strap when working on the backup battery.

Remove the LPC as follows:

IMPORTANT: The LPCs provide sufficient power to support the cabinet while a single LPC is removed and replaced.

- 1) At the ACDPX, turn off the switch for the LPC being replaced.
- 2) At the PDPX2, turn off the circuit breaker for the LPC being replaced.
- 3) At the front of the LPC unplug the AC input plug from the AC input receptacle.
- 4) At the front of the LPC, loosen the two clips securing the output cable connector to the receptacle.
- 5) Unplug the output cable connector.
- 6) Remove the screws that secure the LPC to the shelf.
- 7) At the back of the power shelf, remove the screws that secure the LPC to the UACD shelf.
- 8) Remove the LPC from the shelf.

Replacing the LPC

To replace the LPC:

- 1) Slide the replacement LPC into the shelf.
- 2) At the back of the shelf, use screws to secure the LPC.
- 3) At the front of the shelf, use screws to secure the LPC.
- 4) At the front of the LPC, connect the output cable connector to the output receptacle.
- 5) Fasten the two clips onto the output cable connector.
- 6) At the front of the LPC, plug the AC input plug into the AC input receptacle.
- 7) At the ACDPX, turn on the circuit breaker for the LPC.
- 8) At the PDPX2, turn on the circuit breaker for the LPC.

Verifying the LPC

To verify the operation of the LPC:

- 1) Ensure that the green LED (healthy output) is lit.
- 2) Ensure that the red LEDs (overcurrent and overvoltage) are off.

9.3.8.4 PDPX2

The power distribution panel (PDPX2) electrically splits the -48 VDC into -48 VDC talk voltage and -48 VDC bulk voltage (talk voltage is used by LTUW shelves and bulk voltage is used by DC-to-DC shelf modules). The PDPX2

bulk and talk circuit breakers control the flow of electricity to the cabinet circuit breakers. The stack 1 PDPX2 distributes the bulk and talk voltages to the cabinet circuit breakers in cabinets 1 and 2. The stack 2 PDPX2 distributes the bulk and talk voltages to the cabinet circuit breaker panel in cabinets 3 and 4.

PDPX2 Circuit Breakers and Connectors

The PDPX2 (Figure 143) contains:

- LPC1, LPC2, and LPC3, output circuit breakers for each AC power module
- LPC1, LPC2, and LPC3, ALARMS AND DC OUTPUT cable connectors for each AC power module
- -48 V BULK, circuit breaker, stack 1 and 3
- -48 V TALK, circuit breaker, stack 1 and 3
- -48 V BULK NEXT CAB, circuit breaker for stack 2 or 4
- -48 V TALK NEXT CAB, circuit breaker for stack 2 or 4
- POWER SHARE, circuit breaker for current share between two power shelves (when applicable)
- This is not used in the U.S.

Removing the PDPX



DANGER:

Use extreme caution when you work on power supply components. Power supply voltages can be lethal. Observe all applicable electrical safety precautions for working with high voltages.

Do not wear an ESD strap when working on the backup battery.

IMPORTANT: This procedure removes the OpenScape 4000 system from service when performed on cabinet 1 and removes cabinet 2 from service when performed on cabinet 2.

Remove the PDPX2 (see Figure 143 and Figure 144) as follows:

- 1) Turn off OpenScape 4000 stack 1 or 2, as applicable.
- 2) At the back of the PDPX2, remove the battery manager (refer to Section 8.3.8.1, "Removing the BAM").
- 3) At the back of the PDPX2, label and remove the cables.
- 4) At the front of the PDPX2, label and remove the cable connectors from the receptacles on the right side of the AC power module circuit breakers.
- 5) Remove the two screws that secure the PDPX2 to the upper and lower front shelf supports.
- 6) Remove the PDPX2 from the shelf.

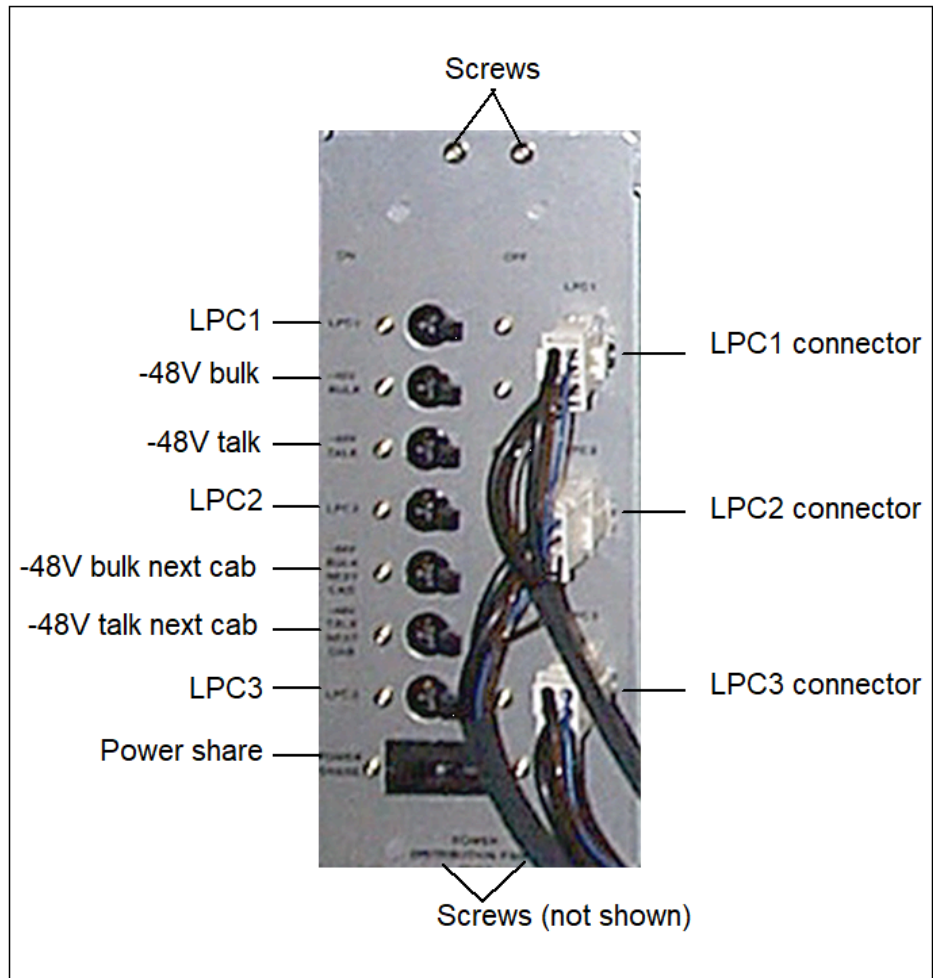

Figure 174: PDPX2 (Front View)

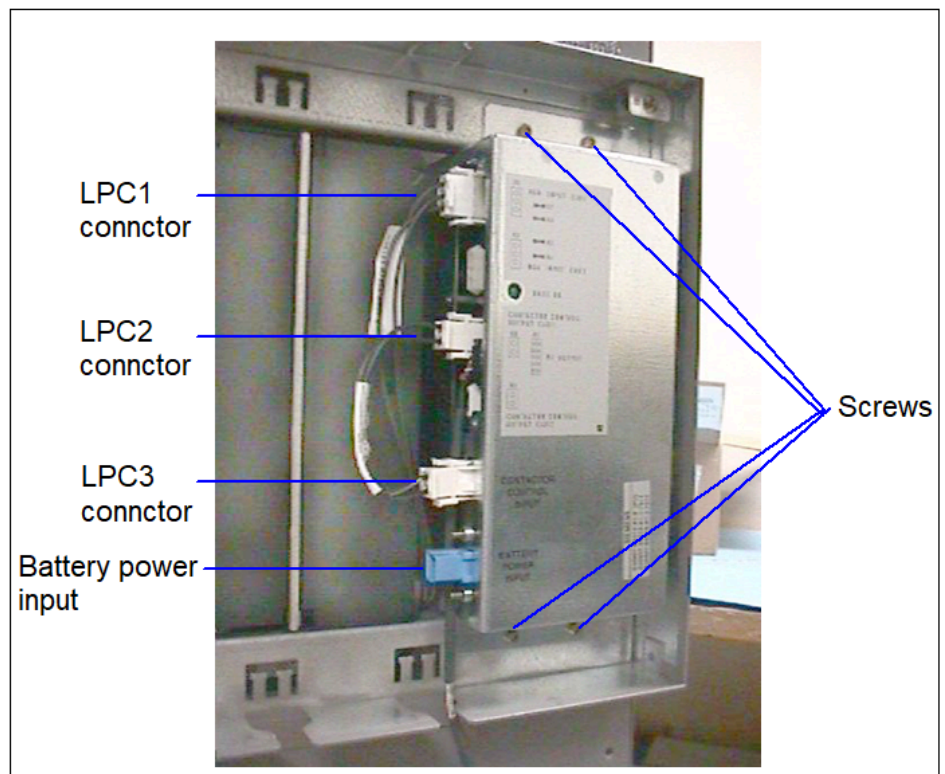

Figure 175: PDPX2, Back View

Replacing the PDPX2

To replace the PDPX2:

- 1) At the front of the UACD, use the screws to secure the PDPX2 to the upper and lower front shelf supports.
- 2) At the front of the PDPX2, plug the connectors into the receptacles on the right side of the AC power module circuit breakers.
- 3) At the back of the PDPX2, replace the cables.
- 4) At the back of the UACD, replace the battery manager (refer to [Section 8.3.8.1, "Replacing the BAM"](#)).
- 5) Turn on OpenScape 4000 stack 1 or 2, as applicable.

Verifying the PDPX2

To verify the operation of the PDPX2:

NOTICE: The condition of the AC power module circuit breakers cannot be verified.

- 1) Verify the bulk circuit breakers by ensuring that the DC OK LED on the DC-to-DC shelf modules in each cabinet are lit.
- 2) Verify the talk circuit breakers by ensuring that the LED on the ring generator board in each cabinet is lit.

9.3.9 UACD (PSR930/PSR930E)

The UACD Powerbox (PSR930/PSR930E) is a new AC/DC Powerbox for 19" Cabinets.

For a detailed technical description please refer to the service information **INF-06-000663**:

<https://www.g-dms.com/livelink/lisapi.dll/Open/3617209>

Information for installation of an OpenScape 4000 System please refer to the relevant Installation Instruction.

9.3.10 UDCD (Zytron)

A unit direct current distribution (UDCD) stack consists of (see [Figure 145](#)):

- One DC input circuit breaker panel (ICBP)
- One DC output distribution panel (ODP)
- Up to 3 Zytron power modules (ZYT)

The UDCD is stackable. One UDCD supports one 4-stack OpenScape 4500. A two-stack UDCD supports two 4-stack OpenScape 4000 system with one + one redundancy.

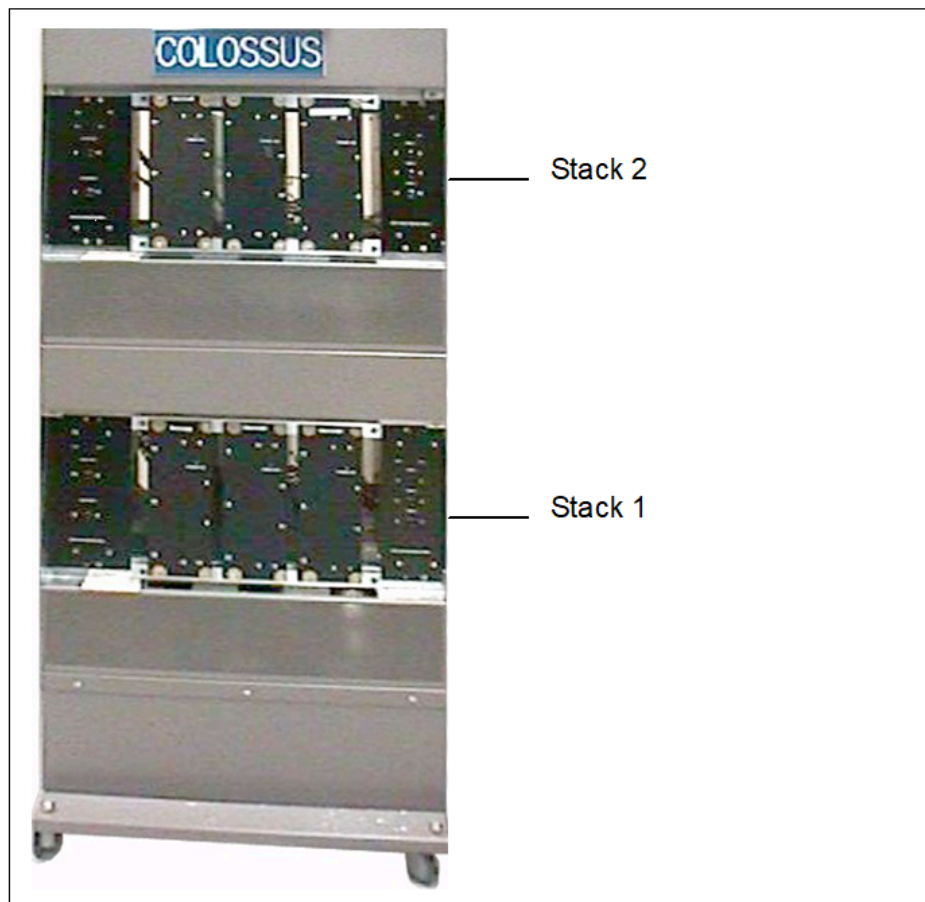

Figure 176: LPC, front view

9.3.10.1 ICBP

The input circuit breaker panel (ICBP) is the main power distribution point for OpenScape 4500 DC systems. The ICBP supplies -48 V power to the Zytron modules (ZYT).

ICBP Connectors and Switches

The front of the ICBP has the following switches (see [Figure 146](#)):

- -48 V bulk, to the cabinet 1 or cabinet 2 bulk circuit breaker
- -48 V bulk next cabinet, to the cabinet 2 or cabinet 3 bulk circuit breaker
- ZYT1, ZYT2, ZYT3, power on and off for the ZYTs

The back of the ICBP has the following connectors:

- Three Anderson quick connectors to the three Zytrons for input power
- ZYT1, ZYT2, ZYT3, ZYT input cables

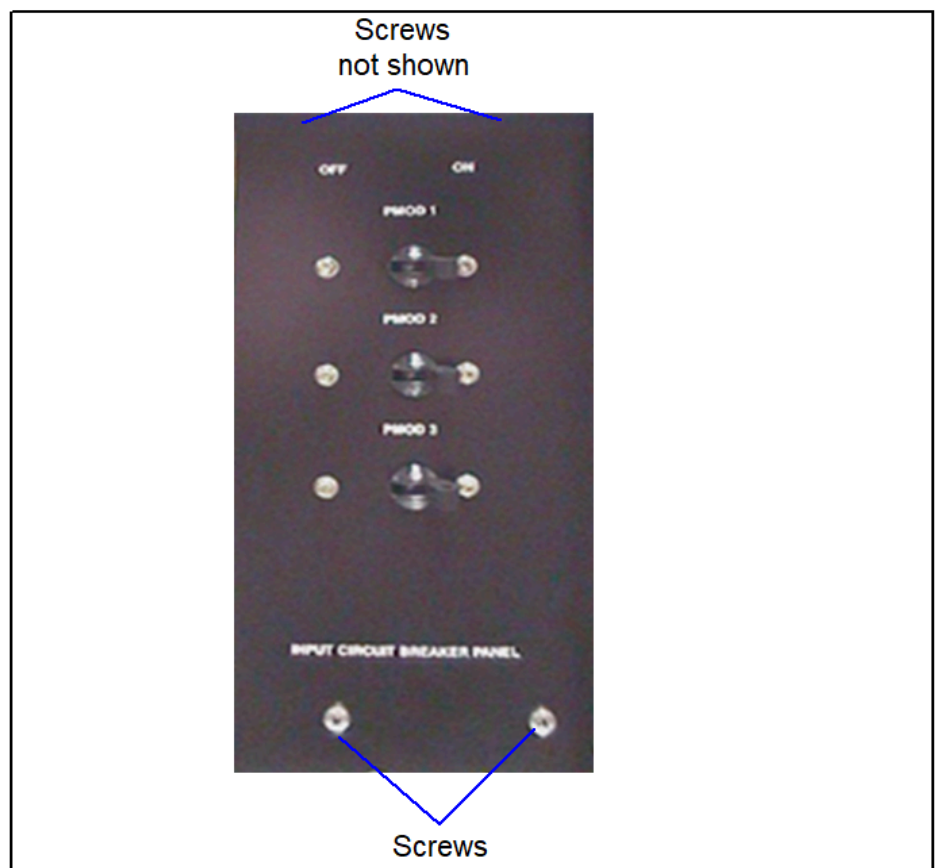

Figure 177: ICBP, OpenScape 4500, Front View

Removing the ICBP



DANGER:

Use extreme caution when you work on power supply components. Power supply voltages can be lethal. Observe all applicable electrical safety precautions for working with high voltages.

Do not wear an ESD strap when working on the backup battery.

IMPORTANT: This procedure removes the OpenScape 4000 system from service when performed on cabinet 1 and removes cabinet 2 from service when performed on cabinet 2.

To remove the ICBP:

- 1) Remove the power from the base unit assembly (BAU)
 - 2) Turn off the respective OpenScape 4000 cabinet stack.
 - 3) Before proceeding, perform the following steps.
-



DANGER:

Before proceeding, perform the following steps.

- a) Establish a ground reference point near the OpenScape 4000 cabinet.
- b) Use the power and grounding tester with the remote ground probe and a previously tested 120 VAC receptacle to perform the ECOS ground path impedance test (5A2). Refer to the power and grounding kit instruction booklet.
- c) Use the analog multimeter to check for less than 1 VAC and 1 VDC between the AC power terminals and the ground reference point and chassis of the UDCD.
- 4) Note the polarity of each of the ICBP cable conductors connected to the junction box (see [Figure 139](#)). Mark the conductors if necessary.
- 5) Remove the nuts that secure the ICBP cable conductors to the circuit breaker terminals.
- 6) Remove the ICBP power cable.
- 7) At the back of the ICBP, label and disconnect all cables.
- 8) At the front of the ICBP, remove the screws that secure the ICBP to the upper and lower shelf supports.
- 9) Slide the ICBP out of the front of the shelf.

Replacing the ICBP

To replace the ICBP:

- 1) Slide the ICBP into the front of the shelf.
 - 2) At the back of the ICBP, reconnect all cables.
-

IMPORTANT: Be extremely careful when tightening the nuts onto the circuit breaker terminals. Excessive torque or side pressure can crack the circuit breaker housing.

While observing the polarity of the ICBP cable conductors, use two nuts fasten to them to their respective circuit breaker terminals.

- 3) Position the strain relief bracket over the ICBP cable and use two screws to secure it.
-



DANGER:

You must perform the following steps before you power on the OpenScape 4000 system. Lethal electrical current can be present on the OpenScape 4000 cabinet frame if the cabinet is not properly grounded.

Verify as follows that the OpenScape 4000 cabinet frame is safe to touch when powered on:

- a) Establish a ground reference point near the OpenScape 4000 cabinet.

Use the power and grounding tester with the remote ground probe and a previously tested 120 VAC receptacle to perform the ECOS ground path impedance test (5A2). Refer to the power and grounding kit instruction booklet.

The following are recommended ground reference points:

- Effectively grounded metal conduit or metal receptacle outlet
- Effectively grounded structural building steel or metal water pipe



DANGER:

Do not touch the OpenScape cabinet frame at this time. Lethal electrical current can be present on the OpenScape 4000 cabinet frame if the cabinet is not properly grounded.

-
- b) Instruct the electrical contractor to turn on the circuit breaker or install the fuse at the DC system switchboard for the DC branch circuit serving the OpenScape 4000 system, and to remove the tags.
- c) Use the analog multimeter to test for less than 1 VAC and 1 VDC between the ground reference point and the UDCD chassis.
- d) Use the power and grounding tester with the remote ground probe and a previously tested 120 VAC receptacle to perform the ECOS ground path impedance test (5A2) on the OpenScape 4000 cabinet frame. Refer to the power and grounding kit instruction booklet.
- 4) Turn on the respective OpenScape 4000 cabinet stack.

Verifying the ICBP

To verify that the ICBP is functioning properly:

- 1) Turn on the main power at the back of the base unit.
- 2) Ensure that the bulk and talk input LEDs on the ODP for the applicable cabinet stack are green.

9.3.10.2 ODP

The output distribution panel (ODP) electrically combines the output of the DC modules and routes it through two circuit breakers that distribute the -48 V talk to the cabinet circuit breakers.

The ODP ([Figure 135](#)) is on the left side of the UDCD.

ODP Connectors, Jumpers, and Switches

The front of the panel contains two circuit breakers that distribute the -48 V bulk and talk to the circuit breakers in cabinets stack 1 and 2 or 3 and 4.

At the back of the ODP are circuits for power signalling. There are three RJ11 4-pin connectors for failure report cables from each of the DC power modules (up to 3), and four FASTON lugs for reporting power supply alarm status to the ADP.



Figure 178: ODP, Front View

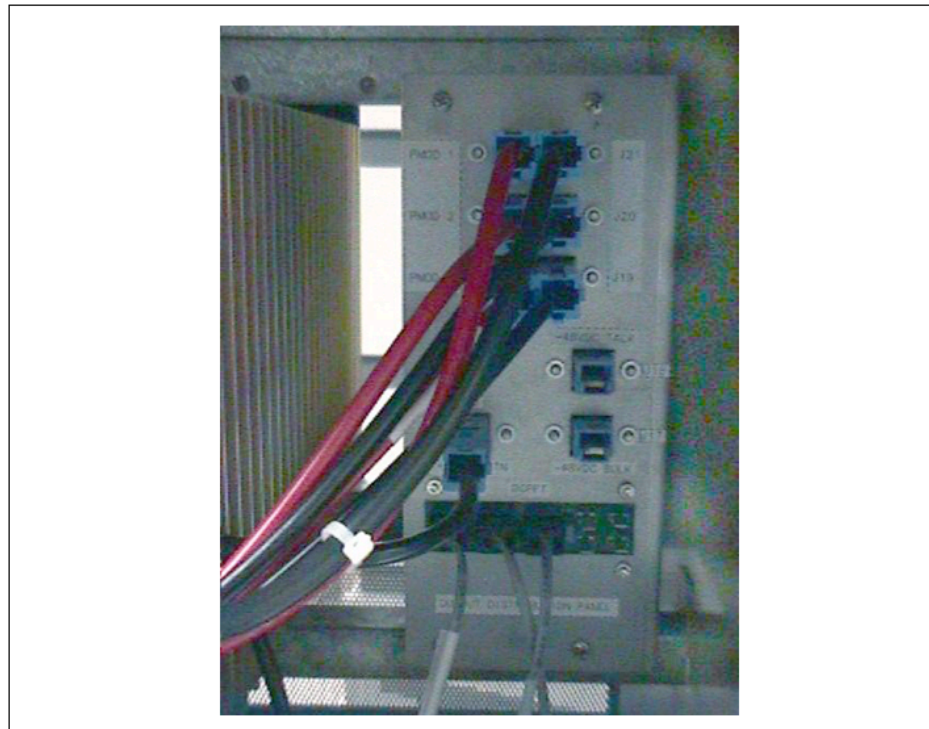

Figure 179: ODP, Back View

Removing the ODP



DANGER:

Use extreme caution when you work on power supply components. Power supply voltages can be lethal. Observe all applicable electrical safety precautions for working with high voltages. Do not wear an ESD strap when working on the backup battery.

IMPORTANT: This procedure removes the OpenScape 4000 system from service when performed on cabinet 1 and removes cabinet 2 from service when performed on cabinet 2.

To remove the ODP:

- 1) Turn off the respective OpenScape 4000 cabinet stack.
- 2) At the back of the ODP panel, label and disconnect all cables.
- 3) Remove power on the ICBP.
- 4) At the front of the ODP panel, remove the four screws that secure the ODP panel to the lower and upper shelf supports.
- 5) Slide the ODP panel out of the front of the shelf.

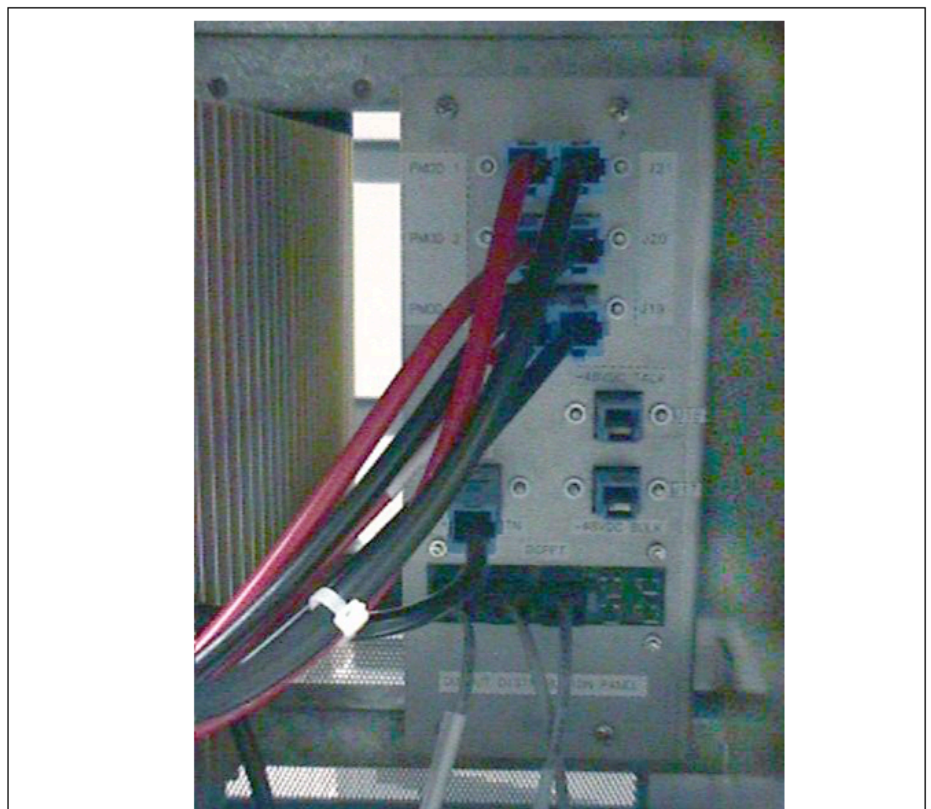

Figure 180: ODP, Back View

Replacing the ODP

To replace the ODP:

- 1) Slide the ODP into the front of the shelf.
- 2) Use screws to secure the ODP panel to the upper and lower shelf supports.
- 3) Ensure that all the circuit breakers on the ODP are turned off.
- 4) At the back of the ODP:
 - a) Reconnect the FASTON connectors.
 - b) Reconnect the failure sense wires.
 - c) Reconnect the three DC power module (Zytron) cables.
 - d) Reconnect the cabinet stack1 and 2 talk cables, as applicable.
 - e) Reconnect the power fail cable.
- 5) Turn on the ICBP.
- 6) Turn on cabinet stack 1 or cabinet 2, as applicable.

Verifying the ODP

To verify the operation of the ODP:

- 1) Turn on the main power at the back of the base unit.
- 2) Ensure that the bulk and talk input LEDs on the ODP to the cabinet stacks are green.

9.3.10.3 ZYT

The ZYTs regulate and condition the -48 V line power received from the ICBP. The output power of the ZYTs is routed to the ODP panel. Connections for current sharing among the ZYTs, and for failure reporting, are provided at the back of the ZYTs.

ZYT LED Indications

The ZYT has a single Power OK LED on the front panel. It is lit when the power module is on.

ZYT Connectors

The back of the ZYT ([Figure 150](#)) has five receptacles:

- The output -48 VDC receptacle is for the 2-conductor connector of the output power cable. The – conductor connects to the ODP panel and the + conductor connects to the talk return isolation block.
- The CTRL1 and CTRL2 receptacles are for the 6-pin RJ11 current share wire connectors. The current share wires transfer current sharing signals between modules.
- The SUPV receptacle is for the 4-pin RJ11 failure sense wire connector to the ODP panel.
- The Input -48 VDC receptacle is for the 2-conductor connector of the input power cable from the ICBP.

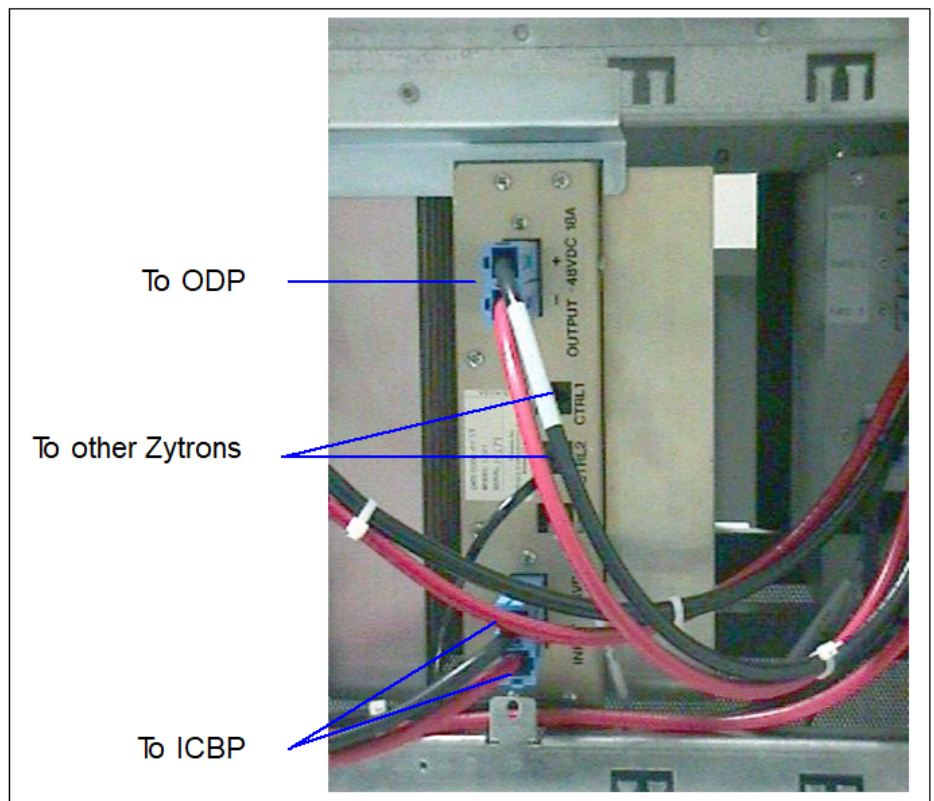

Figure 181: ZYT (Back View)

Removing the ZYT



DANGER:

Use extreme caution when you work on power supply components. Power supply voltages can be lethal. Observe all applicable electrical safety precautions for working with high voltages. Do not wear an ESD strap when working on the backup battery.

To remove the ZYT:

- 1) At the ICBP, turn off the circuit breaker for the ZYT.
- 2) At the back of the shelf, do the following steps:
 - a) Remove the failure sense wire from the ODP and ZYT.
 - b) Remove the current share wire from the ZYT and the adjacent ZYT.
- 3) At the back of the ZYT, disconnect the input power cable connector.
- 4) At the back of the ZYT, disconnect the output power cable connector.



DANGER:

After performing this step, -48 VDC is present in the output power cable connector. Ensure that no metal objects come in contact with the conductors inside the connector.

- 5) At the front of the ZYT, remove the screws that secure it to the upper and lower shelf supports.

- 6) Remove the screws to the brace panel of the Zytrons.
- 7) Slide the ZYT out of the front of the shelf.

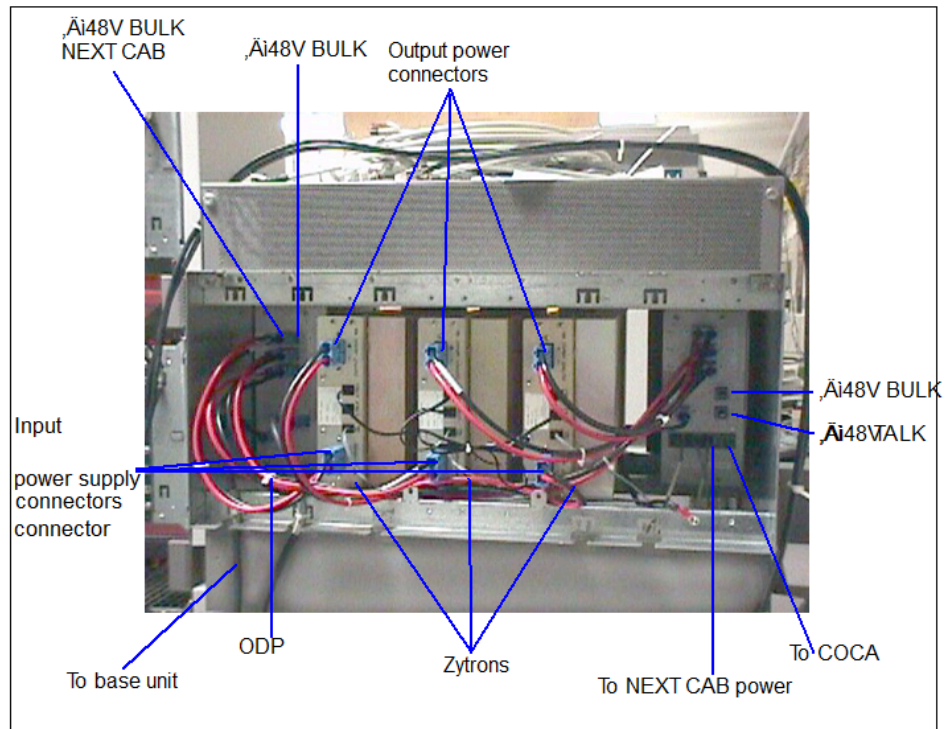

Figure 182: DD (Back View)

Replacing the ZYT

Replace the ZYT as follows:

- 1) Slide the ZYT into the front of the shelf.
- 2) Use screws to secure the module to the upper and lower shelf supports.



DANGER:

While performing this step, -48 VDC is present in the output power cable connector. Ensure that no metal objects come in contact with the conductors inside the connector.

- 3) At the back of the module, reconnect the output power cable connector to the upper receptacle on the module.
- 4) At the back of the shelf, connect the replacement failure sense wire to the applicable receptacles on the ODP and ZYT.
- 5) At the back of the shelf, connect the replacement current share wire to the applicable receptacles on the ZYT and the adjacent ZYT.
- 6) At the ICBP, ensure that the ZYT circuit breaker is turned off.
- 7) At the back of the ZYT, reconnect the input power cable to the lower receptacle.
- 8) At the ICBP, turn on the ZYT circuit breaker.

Verifying the ZYT

Verify the ZYT as follows:

- 1) Ensure that the LED on the front of the ZYT is lit.
- 2) At the back of the ZYT, insert the volt-Ohm-millimeter (VIM) probes into the upper connector. See [Figure 151](#) for assistance in determining the connections.
- 3) Ensure that the VIM indicates that approximately -48 VDC is present.

9.4 Access Modules

9.4.1 OpenScape Access SLC

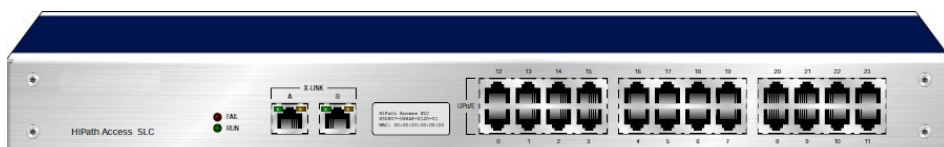

Figure 183: OpenScape Access module SLC (front view)

- Peripheral board: SLC24
- Status indicators (2 x—LED)
- X-Link A/B (2 x— RJ-45 with LED)
- Analog or UP0 interfaces (24 x RJ-45 without LED)

10 Software

11 OpenScape 4000

11.1 OpenScape 4000 in the Customer LAN

In order to be able to control the IP-based access points/OpenScape 4000 SoftGates, the OpenScape 4000 control system must be given access to the IP network via which all access points/OpenScape 4000 SoftGates can be reached.

This is usually the customer's IP network. Once the "Atlantic LAN" is an internal OpenScape 4000 network and may no longer be linked with the customer network, the control processors of the OpenScape 4000 have additional LAN interfaces.

11.1.1 LAN Interfaces

LAN interfaces

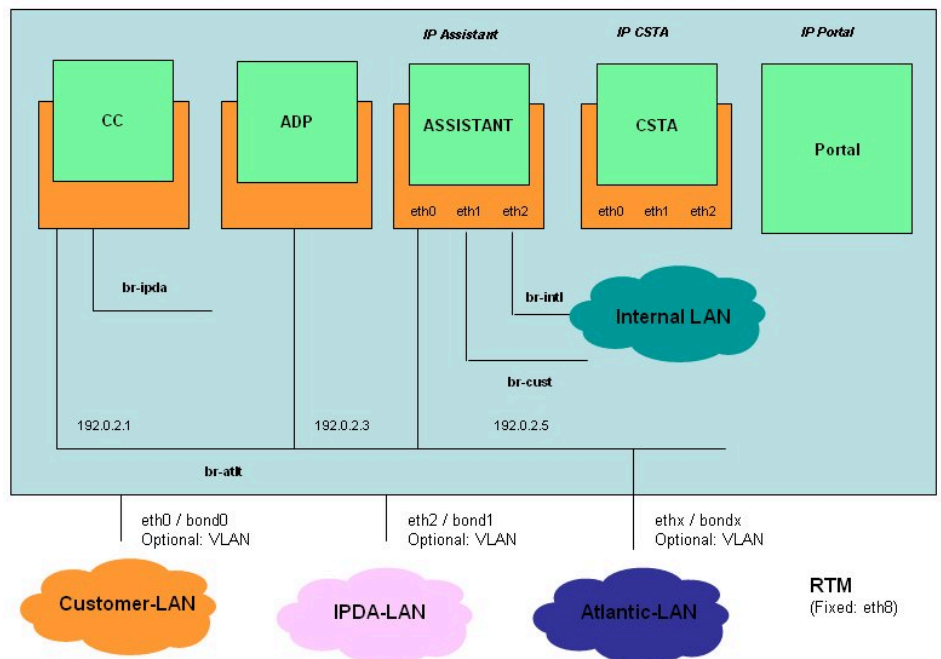

11.1.2 Checking the IP Addresses Used

If all addresses required by the OpenScape 4000 IPDA system have been agreed on with the network administrator of the customer, configuration can commence.

In order to rule out typos and mistakes, all IP addresses should be checked. In other words, check that a new IP address can actually be reached prior to configuration via the **ping** command. If a response is received, the address already exists in the network.

If you wish to configure a CC-A address first, and the **ping** responds, you will have to obtain a different address from the network administrator, as an IP address may never be assigned twice. If, on the other hand, you wish to check the IP address of a router and receive no response, it will not be possible to link OpenScape 4000 IPDA components via this router without taking additional measures.

The "OpenScape 4000 platform Administration" (portal) also performs certain consistency checks when configuring the IP addresses.

11.2 Simplex/Duplex

11.2.1 Feature Description

Virtual Machine

With OpenScape 4000, both the simplex and the duplex configuration are implemented by means of virtual machines. The underlying operating system is Linux.

On each node (EcoServer or VMware VM), separate virtual machines are started for the CC and the ADP, along with a OpenScape 4000 Assistant instance, a OpenScape 4000 CSTA instance and a OpenScape 4000 platform Administration (portal) instance.

The virtual machines simulate the necessary hardware resources and forward the specific hardware interfaces for the encapsulated realtime software.

For an overview please refer to the corresponding sections:

- [Section 10.2.2, "Simplex Operation"](#)
- [Section 10.2.3, "Duplex Operation"](#)
- [Section 10.2.4, "Separated Duplex Operation"](#)

The active ADP is connected to CCA and CCB via the Atlantic LAN. The known Atlantic LAN IP and MAC addresses are used by the virtual machines for the ADP and for the CCs.

Linux High Availability Framework

On each node in a simplex or duplex configuration, a Linux High Availability Framework is in operation.

It has the following functions:

- Supervise the virtual machine instances for the ADPs, CCs, and OpenScape 4000 Assistants/OpenScape 4000 CSTAs/OpenScape 4000 platform Administration (portal) on the own node.
- In case of an error, together with the Linux High Availability Framework on the other node it will be decided whether an ADP switchover is necessary (duplex configuration only).
- Initiate restart or shutdown of the virtual machines for the RMX-based software and OpenScape 4000 Assistant/OpenScape 4000 CSTA/OpenScape 4000 platform Administration (portal) on the own node, if necessary.

- Prevent inconsistent or insecure states like, for instance, two active ADPs at the same time (duplex configuration only).
- Start and monitor the Atlantic LAN. In case of bad throughput/long delays, it is considered defective.
- Supervise the hard disk replication process (duplex configuration only).
- Display failures of the supervised resources.

IP Distributed Architecture (IPDA)

For a Soft Restart to complete the number of 'ready' IPDA shelves and SoftGate is expected to be consistent with the previous state. To ensure this after a Soft Restart/CC Switchover the newly active processor establishes a TCP connection (with TCP SYN) to all previously 'ready' IPDA shelves. This process is supervised by an internal timer which runs for the duration of 100 seconds to allow a numerous retransmission to avoid disconnecting active 2 party calls. No new calls will be possible until all shelves have answered or the timer has expired and the F4385 "END SOFT RESTART" is signalled. If a shelf does not answer it will be taken "OUT OF ATTENDENCE" with F5308.

11.2.2 Simplex Operation

In simplex configuration, one OpenScape EcoServer, EcoBranch or VMware VM is deployed. ADP and SWU run in separated virtual machines.

Host System – Simplex Software Architecture

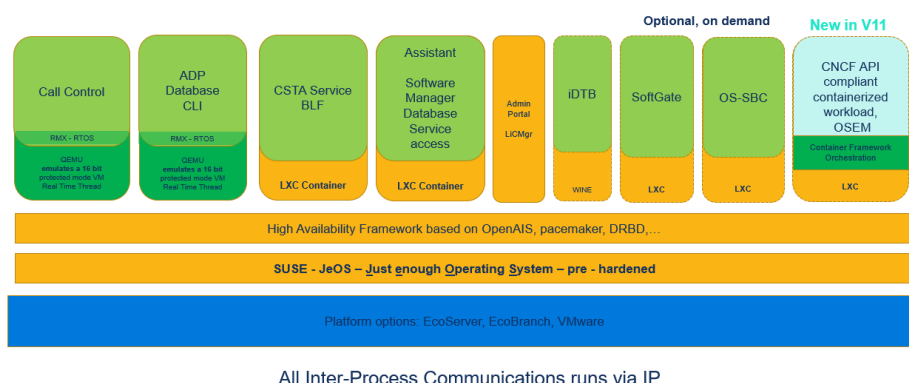

Figure 184: Simplex mode

*JeOS: Just enough Operating System, a security hardened LINUX based OS.

** WINE (originally an acronym for "Wine Is Not an Emulator") is a compatibility layer capable of running Windows applications on several POSIX-compliant OS.

11.2.3 Duplex Operation

For duplex configuration, two EcoServer are required.

This solution supports redundant LAN ports, the failure of central control (CC), ADP, OpenScape 4000 Assistant and OpenScape 4000 CSTA. Also, the OpenScape 4000 platform Administration (portal) will be switched over with ADP, OpenScape 4000 Assistant and OpenScape 4000 CSTA.

The CCs run in hot standby mode and were supplied with continuous data and status updates over the Atlantic LAN.

The ADP, OpenScape 4000 Assistant, OpenScape 4000 CSTA and OpenScape 4000 platform Administration (portal) run in warm standby mode and will be restarted in case of failover.

The SWU failover is independent from a failover of the other services (ADP, OpenScape 4000 Assistant, OpenScape 4000 CSTA, OpenScape 4000 Platform Administration (NGP) and Integrated Display Telephone Book(DTB)).

Host System – Duplex Software Architecture

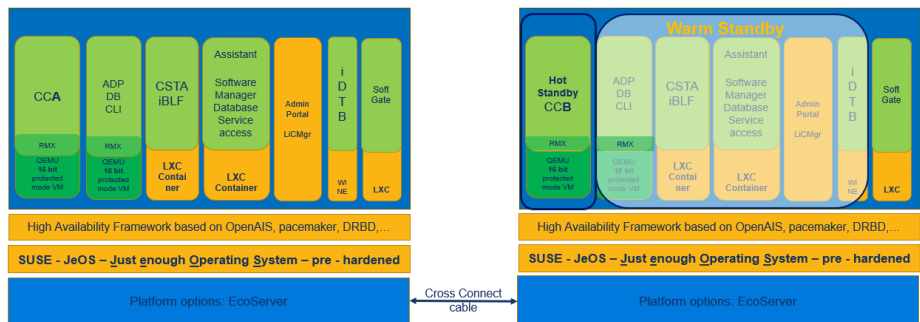

All Inter-Process Communications runs via IP

Figure 185: Duplex mode

*JeOS: Just enough Operating System, a security hardened LINUX based OS.

** WINE (originally an acronym for "Wine Is Not an Emulator") is a compatibility layer capable of running Windows applications on several POSIX-compliant OS.

In operation of a duplex configuration, the virtual machines of the ADP and the OpenScape 4000 Assistant/OpenScape 4000 CSTA/OpenScape 4000 platform Administration (portal) on the primary node are active, while the correspondant virtual machines on the secondary node are offline. The ADP and the OpenScape 4000 Assistant/OpenScape 4000 CSTA/OpenScape 4000 platform Administration (portal), which reside on the same node, can only change their active/offline states together. Thus, an OpenScape 4000 Assistant/OpenScape 4000 CSTA/OpenScape 4000 platform Administration (portal) is only active on that node on which the virtual machine for the ADP is active.

LAN ports

The LAN ports of the OpenScape 4000 Communication Server can be configured in hot redundant mode and connected to two redundant Ethernet switches. L1 failure of one Ethernet switch results in hot switch-over to the redundant Ethernet switch without losing calls or application connectivity.

Prerequisite:

The system has been set up using LAN bonds on the IPDA interface (see service documentation **OpenScape 4000, Installation, Configuration and Migration**).

The following LAN ports are available:

- 2 LAN ports in hot-redundant mode for call control - IPDA LAN

- 2 LAN Ports for OpenScape 4000 Assistant/OpenScape 4000 CSTA/OpenScape 4000 platform Administration (portal) - Customer/Management LAN
- 2 LAN Ports for OpenScape 4000 Duplex - Corosync LAN
- Atlantic LAN

Redundant operation can be configured via yast and the OpenScape 4000 platform Administration Portal.

Replication of ADP, SWU, and OpenScape 4000 Assistant/OpenScape 4000 CSTA/OpenScape 4000 platform Administration (portal) Hard Disk

To enable complete recovery of the RMX-based software and the OpenScape 4000 Assistant/OpenScape 4000 CSTA/OpenScape 4000 platform Administration (portal) in case of failover, the relevant virtual hard disk partitions and files on the primary node are replicated onto the hard disk of the secondary node. This is achieved by the DRBD (Distributed Replicated Block Device) software, which replicates the relevant files over the LAN.

The current DRBD status can be checked under **OpenScape 4000 Administration > Status > DRBD Status**.

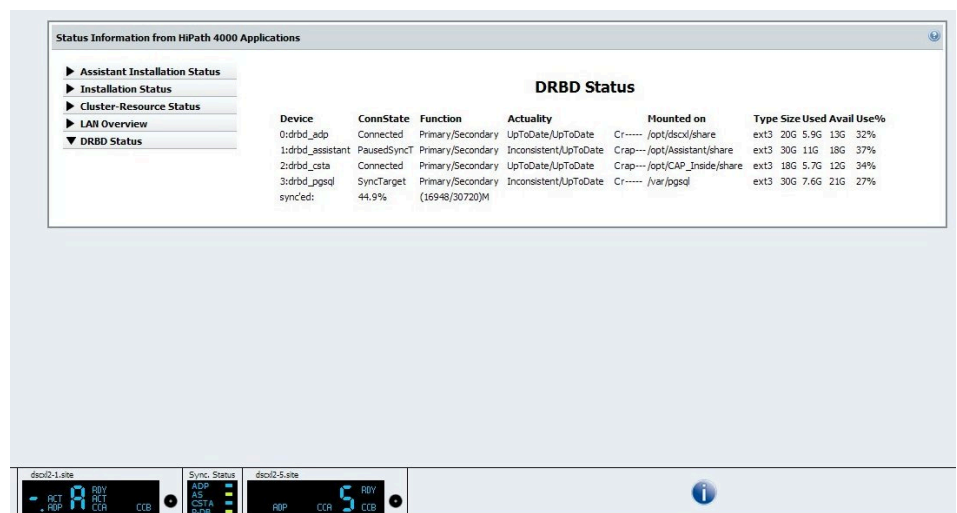

Figure 186: OpenScape 4000 Platform Administration > DRBD Status

A compact status representation of the four DRBD partitions is shown in the Control Panel under **Sync. Status**.

- Blue: Partitions are synchronized.
- Yellow: Partitions are being synchronized (ConnState: SyncTarget) or will be synchronized (ConnState: PausedSyncT)
- Red: Error (e.g. function: primary/secondary not implemented because a node is not accessible for DRBD (see [Error #5: DRBD split brain situation during switch over](#)))

A synchronous call state and data replication takes place in real-time between the cluster nodes (CCA/CCB).

Both nodes are connected via the Corosync network then synchronous replication is used (in DRBD terminology: protocol C). This implies that all data blocks are written on the hard disk of the active node and, at the same time, on the hard disk of the standby node. The file system of the active node is notified when the writing process has been successful on both nodes.

Fail over Scenarios

see [Section 10.2.5, "Switch Over Scenarios for Duplex and Separated Duplex"](#).

11.2.4 Separated Duplex Operation

OpenScope 4000 separated duplex offers a higher resilience of call control / SWU due to different locations of the communication servers.

Host System – Separated Duplex Software Architecture

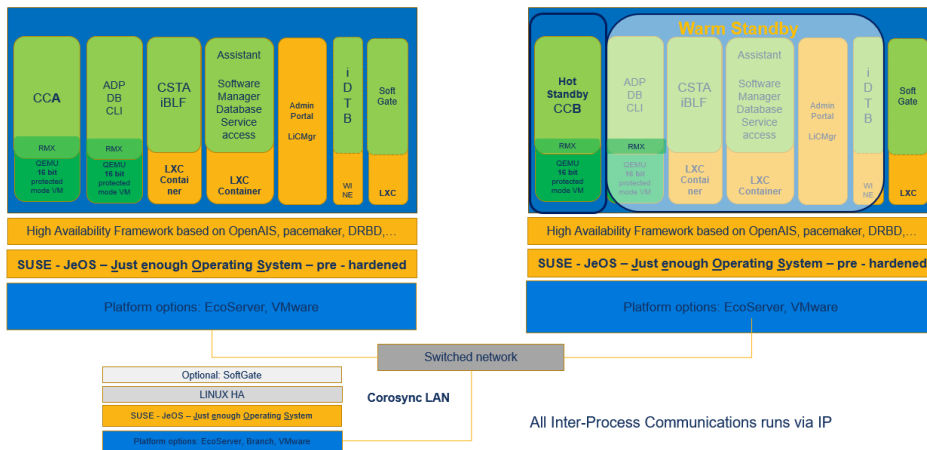

Figure 187: Separated Duplex

*JeOS: Just enough Operating System, a security hardened LINUX based OS.
 ** WINE (originally an acronym for "Wine Is Not an Emulator") is a compatibility layer capable of running Windows applications on several POSIX-compliant OS.

A separated duplex system is a server cluster system and always consists of three servers (nodes):

- Node 1
- Node 2
- Quorum Node

On all three nodes the same LINUX-HA-SW Suite is running (incl. Configuration).

For information on the resulting network requirements, refer to [Section Prerequisites](#).

IMPORTANT: If the bandwidth is too low or the RTT (Round Trip Time) too high on the cross link, the system performance may be adversely affected.

A real-time synchronization of Call-state and Data replication between the two server nodes CCA & CCB happens over a so called Cross Link.

The Cross Link between Node 1 and Node 2 must be 1Gbit/sec (e.g. Dark Fiber) and provide a 10ms Round Trip Time (RTT). The average bandwidth across this L2 switched Cross link (Corosync and Atlantic Lan) is only around 10 Mbit/s, however certain administrative actions require a substantially higher band width on the Corosync LAN (Data Bursts).

NOTICE: Using low Bandwidth i.e. high RTT over Cross Link can have adverse effects on the availability/stability of the system.

The Cross Link between Node 1 and Node 2 to the Quorum node, a 10ms RTT is needed and a bandwidth greater than 1Mbit/s. It is recommended to have 10Mbit/s to ensure functionality during SW update scenarios.

Via the Corosyn LAN the communication is handled with the objective of the synchronization/Quorum on which server the service should run (cluster resources).

The data transported via the Atlantic and Corosync LAN is not encrypted and should therefore take place via a trusted network.

IMPORTANT: The Quorums host should be positioned at a third location away from the other servers in order to ensure maximum failsafe reliability.

Explanation of terms

- Quorum

A cluster has a quorum if more than half of the nodes known in the cluster are online. In relation to a two-node cluster this means that it would only be active if both nodes are online.

A separated duplex system therefore has an auxiliary node - the so-called quorum node - at its disposal.

If the two communication servers cannot communicate via the cluster tie trunks, there is a risk that the overall system will be separated into undesirable independently operating units, which almost always threatens data integrity (split-brain problem). The quorum node supports the cluster in the decision as to which node should be shut down.

The quorum node is always obligatory.

If the quorum node fails during normal operation (not during a switchover), the redundancy of the CCA/CCB (Hot Standby) remains intact.

Although only one quorum node can be available, it does not represent a single point of failure, as it is not required for basic operation of the separated duplex.

The Quorums node serves exclusively for the creation of the Quorum.

Deployments

Scenario 1: Separated Duplex for OpenScape 4000

OpenScape 4000 software is installed on two OpenScape 4000 communication server each with one EcoServer.

Consisting of following hardware components:

- 2x OpenScape 4000 with EcoServer

plus the required software licenses:

- OpenScape 4000 Basic License,
- Duplex License.

Scenario 2: Separated Duplex for VMware

OpenScape 4000 software is installed on two VM Modes in different locations.

Consists of SW plus following software licenses:

- OpenScape 4000 Basic License,
- Duplex License.

Prerequisites

- For customer and IPDA LAN the same is valid as for Duplex.
- Atlantic LAN: Node 1 and 2 must be located in the same sub network (same layer 2 broadcast domain).
- The Atlantic LAN IP addresses are fixed and cannot be changed.
- The default router for node 1 and 2 must have the same configuration (IPDA LAN and customer LAN).
- Customer LAN and IPDA LAN can also be combined if required.
- The Quorums node must be at least connected with the Corosync LAN.
- Only IP access points (AP 3700IP/AP3300IP) and/or OpenScape 4000 SoftGate can be connected.

For more prerequisites please refer to the release note.

Standalone mode

Should it happen that the node no longer has the required quorum at its disposal, a node can also be switched administratively to standalone mode:

Linux console: `standalone_operation enable`

The OpenScape 4000 System Simplex can continue to be operated in this way until the partner node and quorum node are operational again.

NOTICE: Standalone mode only can be used on Separated Duplex and only on node A or node B (not for the Quorum node). Only one of those nodes can have standalone operation enabled at the same time.

(Other options: `disable` and `status`)

EcoServer cable has to be plugged in.

11.2.5 Switch Over Scenarios for Duplex and Separated Duplex

Error #1: The active CC breaks down or is restarted

Due to a break down or restart of the active CCA it is no longer available.

CCB, which has been on standby previously, will assume the active role. CCA gets switched to standby.

In case of SWU failover:

- no loss of established calls.
- no data loss (e.g. billing, configuration data, etc.).
- other virtual machines (ADP, OpenScape 4000 Assistant, OpenScape 4000 CSTA, OpenScape 4000 platform Administration (portal)) are not affected.

Error #2: The active ADP breaks down / gets unreachable

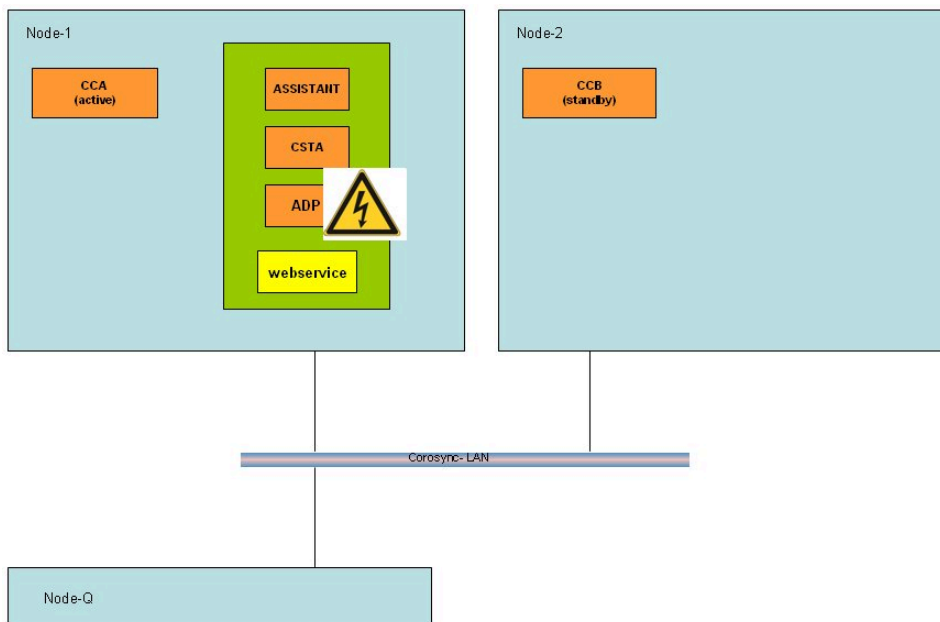

Figure 188: Active ADP breaks down / gets unreachable

Due to a software failure of the virtual machine (not RMX) the active ADP breaks down and gets unreachable.

If the Linux High Availability Frameworks on both nodes are available and decide that a failover is necessary, the previously active ADP, OpenScape 4000 Assistant, OpenScape 4000 CSTA and OpenScape 4000 platform Administration (portal) on node A will be turned offline, and the ADP, OpenScape 4000 Assistant, OpenScape 4000 CSTA and OpenScape 4000 platform Administration (portal) on node B will be started up.

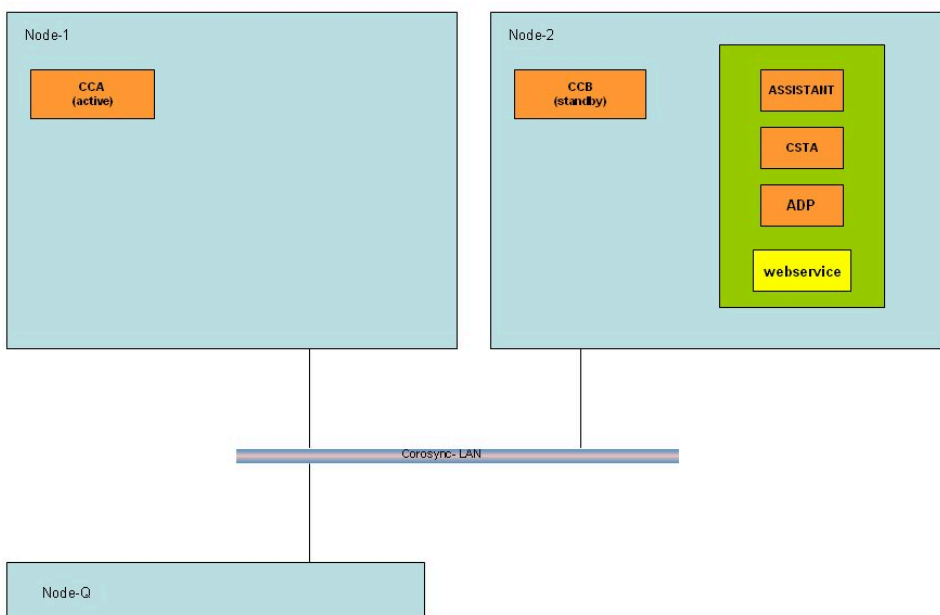

Figure 189: Active ADP unreachable -> after switch over

Due to hard disk mirroring between both nodes (see [Replication of ADP, SWU, and OpenScape 4000 Assistant/OpenScape 4000 CSTA/OpenScape 4000 platform Administration \(portal\) Hard Disk](#)), the ADP virtual machine and OpenScape 4000 Assistant/OpenScape 4000 CSTA/OpenScape 4000 platform Administration (portal) can start up with the latest software and data. To the external applications, an ADP failover appears as a connection loss and a loss of dynamic data. Thus, the external applications need to reconnect to the ADP.

In case of ADP failover:

- No loss of established calls.
- Restart of the virtual machines of ADP/ OpenScape 4000 Assistant (offline time < 5 - 10 minutes).
- Restart of the virtual machine of OpenScape 4000 CSTA (offline time < 5 minutes).
- To the external applications, an ADP failover appears as a connection loss and a loss of dynamic data. Thus, the external applications need to reconnect to the ADP.

Error #3: The node with the active ADP is out of order

Due to a hardware or software failure or due to maintenance the active node is out of order.

CCB, which has been on hot standby, assumes the active role now.

The Linux High Availability Framework of node B realizes the unavailability of the partner Linux High Availability Framework residing on node A and decides for the activation of the ADP and OpenScape 4000 Assistant/OpenScape 4000 CSTA/OpenScape 4000 platform Administration (portal) on node B.

When node A recovers, CCA will be started and acts as stndby CC. The Linux High Availability Framework on node A realizes that the ADP on node A should not be started because the ADP on node B is active already.

Error #4: The node with the active ADP and Quorum node are out of order

IMPORTANT: Only valid for separated duplex!

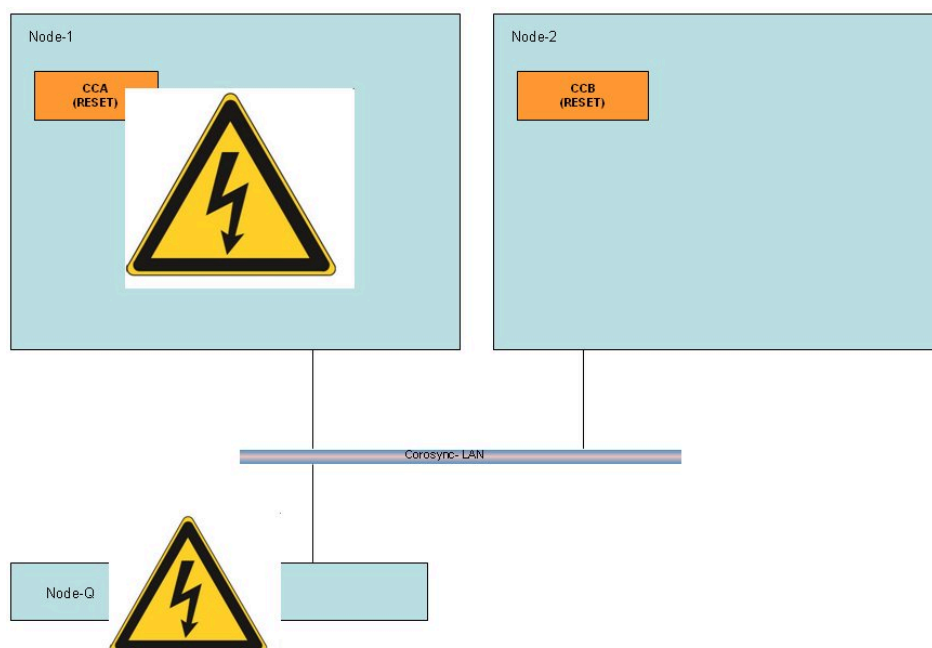

Figure 190: Active ADP and Quorum node are out of order

If there is no connection to the Quorums node, neither ADP, OpenScape 4000 Assistant/OpenScape 4000 CSTA/OpenScape 4000 platform Administration (portal) functions nor telephony (CCA/CCB) will be available. The reason for this is that a node cannot independently decide whether it should be active, since it has no information on the status of the partner and communication via the cPCI backplane is not possible in comparison with cPCI duplex.

Shutdown of ADP, OpenScape 4000 Assistant, OpenScape 4000 CSTA, OpenScape 4000 platform Administration (portal) and webservice also on node 2. Reset of CCB.

Error #5: DRBD split brain situation during switch over

IMPORTANT: Only valid for separated duplex!

Split brain is avoided on OpenScape 4000 through:

- Standard Duplex systems have backplane awareness of the partner node;
- Separated Duplex system needs a minimum of two nodes to decide who the primary node must be (e.g. CCB + Quorum, or CCA + CCB).

NOTICE: The cluster decision can be override via console command (See [Section 10.2.4, "Separated Duplex Operation"](#)). In addition, there is a 5 minutes delay prior to switching cluster resources to another node. This delay is to avoid the migration of all resources for a short term outage (e.g. short network outage).

11.2.6 Manual Switch Over

Manual switch over of CC

With AMO REST you can invoke a manual switch over of the CCs.

```
EXEC-REST:TYPE=UNIT,UNIT=BPA,RSLEVEL=RESTART;
```

or

```
EXEC-REST:TYPE=UNIT,UNIT=BPB,RSLEVEL=RESTART;
```

Manual switch over of ADP

The active ADP can be shut down, e.g. for maintenance.

OpenScape 4000 Administration > Maintenance > Shutdown System

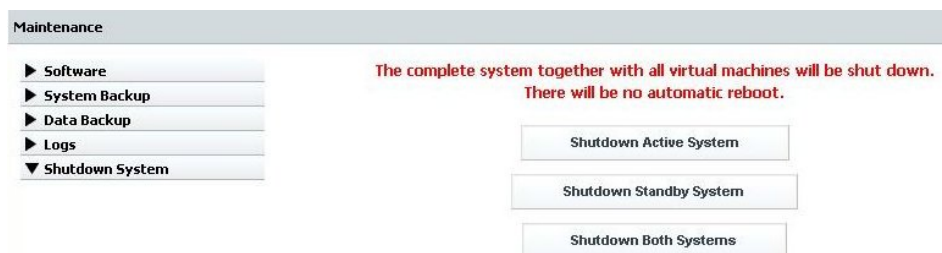

Figure 191: System shut down with OpenScape 4000 platform Administration

11.3 Supported Interfaces

OpenScape 4000 supports the following interfaces:

Trunks

- S0 (basic rate interface)
- E1 (S2M) (primary rate interface 30 channels)
- T1 (primary rate interface 24 channels)
- Analog
- Native SIP (SIP service provider)

Networking interfaces

- Basic Rate S0 / Primary Rate E1 (S2M) / T1
- The following protocols are supported: CorNet NQ, QSIG, DSS1, CAS
- Analog e.g. MFC-R2, E&M, ...
- IP trunking (H.323 Annex M1)
- SIP trunking to HiPath/OpenScape platforms with SIP-Q protocol
- Native SIP trunking for IP interoperability with 3rd-party manufacturers

User interfaces

- UP0/E
- Twin-wire interface for connecting OpenStage T telephones
- HiPath Feature Access (HFA) for OpenStage HFA endpoints
- Native SIP for IP Endpoints:
- e.g. OpenStage SIP

- S0 bus
- S0 port for ISDN terminal devices
- a/b port (CLIP, name display, and MWI possible) for analog terminal devices

11.4 Portlist

The Interface Management Database (IFMDB) contains information regarding the IP ports used by all OpenScape 4000 products.

See product HomePage

11.5 Hardware Architecture Table

The hardware architecture table is an ASCII file on the :PDS: area of the hard disk. It can be displayed with:

e.g. `STA-LIST: " :PDS:APSU/HWARCH0 " , , ,M,N;`

The hardware architecture table shows among other things which parameters have been configured during deployment installation for the AMOs DBC and APC for a given ARCHITECTURE and a given ARCHITECTURE TYPE.

11.5.1 Layout

Areas on the hard disk (RMX)

Table 169: Hard disk layout

AREA	Logical name	Size in 64k blocks	Size in MB
A	Administration area	2	0
E	PDS	7200	450
F	DBDA	1600	100
G	CGD	2400	150
H	DMS (DSY)	1120	70
I	SCR	16384	1024
J	GLA	7200	450
K	DIAG	9868	617

11.5.2 Configuration Batch

Set up the hard disk on controller 1

```
ADD-DTSM:A1,HD,45775,512,"STDH6",255;
ADD-DCSM:A1,1,HD,"STDH6";
ADD-
DASM:A1,1,7200&1600&2400&1120&16384&7200&9868,4096&4096&4096&4096&4096;
ADD-DLSM:A1,1,E,"PDS:";
ADD-
DLSM:A1,1,F,"DBDA:"&"DBD:"&"TMD:"&"PAS:"&"AMD:"&"DMP:";
ADD-DLSM:A1,1,G,"CGD:";
ADD-DLSM:A1,1,H,"DMS:"&"DSY:";
ADD-DLSM:A1,1,I,"SCR:";
ADD-DLSM:A1,1,J,"GLA:";
ADD-DLSM:A1,1,K,"DIAG:";
```

Set up of a virtual hard disk on controller 4 (for system backup)

```
ADD-DCSM:A1,4,HD,"STDH6";
ADD-
DASM:A1,4,7200&1600&2400&1120&16384&7200&9868,4096&4096&4096&4096&4096;
ADD-DLSM:A1,4,E,"PDS:";
ADD-
DLSM:A1,4,F,"DBDA:"&"DBD:"&"TMD:"&"PAS:"&"AMD:"&"DMP:";
ADD-DLSM:A1,4,G,"CGD:";
ADD-DLSM:A1,4,H,"DMS:"&"DSY:";
ADD-DLSM:A1,4,I,"MOD-SCR:";
ADD-DLSM:A1,4,J,"GLA:";
ADD-DLSM:A1,4,K,"DIAG:";
```

Set up of a virtual hard disk on controller 6

```
ADD-DCSM:A1,6,HD,"STDH6";
ADD-
DASM:A1,6,7200&1600&2400&1120&16384&7200&9868,4096&4096&4096&4096&4096;
ADD-DLSM:A1,6,E,"PDS:";
ADD-
DLSM:A1,6,F,"DBDA:"&"DBD:"&"TMD:"&"PAS:"&"AMD:"&"DMP:";
ADD-DLSM:A1,6,G,"CGD:";
ADD-DLSM:A1,6,H,"DMS:"&"DSY:";
ADD-DLSM:A1,6,I,"MOD-SCR:";
ADD-DLSM:A1,6,J,"GLA:";
ADD-DLSM:A1,6,K,"DIAG:";
```

12 OpenScape 4000 CSTA

OpenScape 4000 CSTA is a protocol converter, which converts the internal **OpenScape 4000 ACL** (Application Connectivity Link) protocol into a standardized CSTA III protocol, based on the encoding types ASN.1 (Abstract Syntax Notation One) and XML (eXtensible Markup Language). The software can be installed as a OpenScape 4000 integrated installation.

For more information please refer to **OpenScape 4000, OpenScape 4000 CSTA and Phone Services, Service Documentation**.

13 OpenScape 4000 Assistant

13.1 Important Information

IMPORTANT: For the administration of OpenScape 4000 networks via the OpenScape 4000 Manager it is recommended to use at the OpenScape 4000 Manager a version equal to or higher than the highest version used on any of the OpenScape 4000 Assistants at the customer's side. Otherwise, because of the different database structures used at OpenScape 4000 Manager and OpenScape 4000 Assistant side, problems with the data synchronization might occur. Additionally, the OpenScape 4000 Manager would not be able to administer all OpenScape 4000 Assistant features, since it would not be possible for the data-UPLOAD to incorporate the new imported OpenScape 4000 Assistant data into the OpenScape 4000 Manager database (this data would be ignored). Please refer also to the information related to this issue in the OpenScape 4000 Assistant/Manager release notes.

13.2 OpenScape 4000 Assistant Applications

This chapter describes the applications installed during the installation process. It also gives a short overview of the tasks performed by each application.

For further information about the applications, please refer to the corresponding online help.

Software Management

- Application Administration

The "Application Administration" application is needed to install, replace, and remove applications. In addition, you can display the names of the installed applications and the installation packages that are on the installation medium. DVDs, CDs, USB Memory Devices, and the installation directory on the hard disk can be used as installation media.

- Backup & Restore

The "Backup & Restore" allows you to save configuration data or software from RMX and Linux applications to a backup copy file and restore the data as required. This means that an accurate backup copy of the data and/or software is available in the event of a system failure.

- Software Activation

When either a Revision Level Complete RLC (Minor Releases / Fix Releases) or a Patch Package PP (Fix Releases / RMX-HotFixes) is transferred using Software Manager to a OpenScape 4000 system running SUSE Linux Enterprise Server (SLES), it must be subsequently activated there. The Software Activation service function is used for activation.

- Software Transfer

The SWM (Software Manager) component is part of OpenScape 4000 Assistant. It is a tool for transferring the following Hotfixes and Releases via a TCP/IP network:

- Hot Fixes HF / CSTA HotFixes (CSTA_HF),
- Hot Fixes HF / OpenScape 4000 Platform Hot Fixes (PLT_HF),
- Hot Fixes HF / RMX Hotfixes (RHF),
- Hot Fixes HF / Unix Hot Fixes (UHF),
- Fix Releases FR (Patch Packages (PP) / Revision Level Complete (RLC)
- Minor Releases MR (Patch Packages (PP) / Revision Level Complete (RLC)

- TSDM

TSDM is an abbreviation for TDM Software Download Manager. This application enables software updates on TDM (Time Division Multiplex) variants of OpenStage phones and the Up0 Extender on OpenScape 4000 systems. In addition, a customer logo can be delivered to OpenStage devices supporting this feature, trace and exception log data can be uploaded from the OpenStage device to the switch.

Access Management

Access Management is the access control component for OpenScape 4000 servers. It controls which users are allowed to access a specific server, and which applications and access rights these users may use. Possible users are customer administrators and service technicians that manage OpenScape 4000 systems.

- Session Management
 - Change Password
 - Session Manager
- License Management Tool
- License Management

The License Management application allows the administrator to obtain information on the installed licenses and to configure the location of the CLA. This protects all OpenScape 4000 applications and all software that requires a license and that a customer might want to install.

- Account Management
 - Account and Password Policy
 - User Account Administration
 - System Account Administration
 - Access Right Configuration
 - Access Right Group Configuration
 - Export User Reports
- Emergency Password Reset Configuration

Emergency Password Reset (EPR) provides a mean to reset administrator (user "engr") password in case the password was lost or the system was corrupted. Prior to using that feature, the system must be configured appropriately, and the feature must be enabled by the system administrator.

- Manage Web Server Certificates
 - Certificate for this Web Server
 - Activate
 - Generate
 - Import
 - Generate via CSR
 - Certificate Network Management
 - Root Certificate
 - Sign CSR signieren
 - Import Certificate Authority for distribution
- Security Mode Configuration
- Configuration of PKI Authentication
- Customize Banner on Login Page

Utilities

- XIE web service

Base Administration

- Webmin

"Webmin" is the basic administration service for the configuration of the system resources and the TCP network. It is also used for operating the system, e.g. shutdown.
- Logging Management

Logging Management allows you to search the logon events, using a standard query. It also allows you to modify, create and save queries.
- Application Control

Expert Mode

- Signalling and Payload Encryption

With the "Signalling and Payload Encryption" of the OpenScape 4000 Assistant it is possible to set APN SecureTrace PassPhrase (Access Point Network) and MEK (Master Encryption Key).

 - Administration
 - SPE Root Certificate
 - SPE Certificate
- Expert Access (ComWin)
- Gateway Dashboard
- Platform Portal
- SSH connection to OpenScape 4000 Assistant
- Gateway Manager
- CSTA

- Direct WBM/SSH Access

"Direct WBM/SSH Access" is an application that enables automatic/manual password distribution for all accounts on IP boards, and for creating, editing (i.e. updating) and deleting additional user accounts as well.

The application is accessible for administrators only and ensures secure password distribution.

System Management

- OpenScape 4000 Administration
- PhoneMail Administration
- OpenScape 4000 / HG3550 Administration

Configuration Management

Configuration Management (CM) enables the system- and/or network-wide configuration of system data, line (trunk) data, station data, least cost routing, and personal data.

Das Configuration Management includes the following functions:

- Network
- System Data
- Station
- Tables
- Groups
- Personal Data
- Least Cost Routing
- OpenScape/HiPath Inventory Management
- IPDA Wizard
- Scheduled Batch
- Session Log
- CHESE Wizard
- User Settings

Diagnostics

- Trace Download

- Test Simulation of Key Function Activity (TSKA)

The TSKA application enables the OpenScape 4000 Assistant user to display and simulate OptiSet, optiPoint and OpenStage devices at a customer's site. TSKA displays:

- display messages,
- LED status,
- function key assignments,
- "Self Labeling Key" texts.

The user can remotely simulate the pressing of function keys and keys of the keypad. Therefore, a graphical representation of the device in a browser window is provided.

TSKA allows also to open the WBM (Web Based Management) page for an IP Phone connected via a CGW board.

- IPTrace
- Fault Management
 - Alarm Configurator
 - SNMP Configurator

13.3 User Accounts

For information on the OpenScape 4000 Assistant user accounts please refer to **OpenScape 4000 Manager, Installation and Service Manual, Service Documentation**.

13.4 Notification Mechanism and Usage Scenarios

This section is intended to provide clarification of functionality and interaction when AMOs and OpenScape 4000 Manager and/or OpenScape 4000 Assistant are used at the same time for switch configuration.

Information is provided in the form of answers to frequently asked questions (FAQ).

[Section 12.4.2, "Networks without OpenScape 4000 Manager"](#) addresses networks involving AMOs and OpenScape 4000 Assistant, but without OpenScape 4000 Manager.

[Section 12.4.3, "Networks with OpenScape 4000 Manager"](#) addresses networks involving AMOs, OpenScape 4000 Assistant and OpenScape 4000 Manager.

13.4.1 The Notification Mechanism

How the OpenScape 4000 Assistant database is synchronized with the switch database

This section of the document explains the notification mechanism. This mechanism keeps the OpenScape 4000 Assistant database synchronized with the switch database when AMO commands are executed (with anything other than the OpenScape 4000 Assistant itself: direct AMO commands, AMO commands coming from the OpenScape 4000 Manager, etc.).

13.4.1.1 Operation of the Notification Mechanism

This is how the notification mechanism works (numbered steps refer to [Figure 161 Notification Mechanism](#)):

- 1) An AMO command is executed on the switch.
- 2) The switch updates its database.
- 3) The switch sends a notification to the OpenScope 4000 Assistant, with the AMO command that was executed.
- 4) The OpenScope 4000 Assistant puts the notification in its internal queue.
- 5) As soon as it can, it retrieves the notification from that queue.
- 6) The OpenScope 4000 Assistant generates one or more query AMO commands to retrieve the changes from the switch database (query AMO commands are commands like REG-<NOUN>, DISPLAY-< NOUN>, EXEC-UPLOL, EXEC-UPLO2, that is, AMO commands that read the switch configuration).
- 7) The OpenScope 4000 Assistant updates its database using the information just queried from the switch.

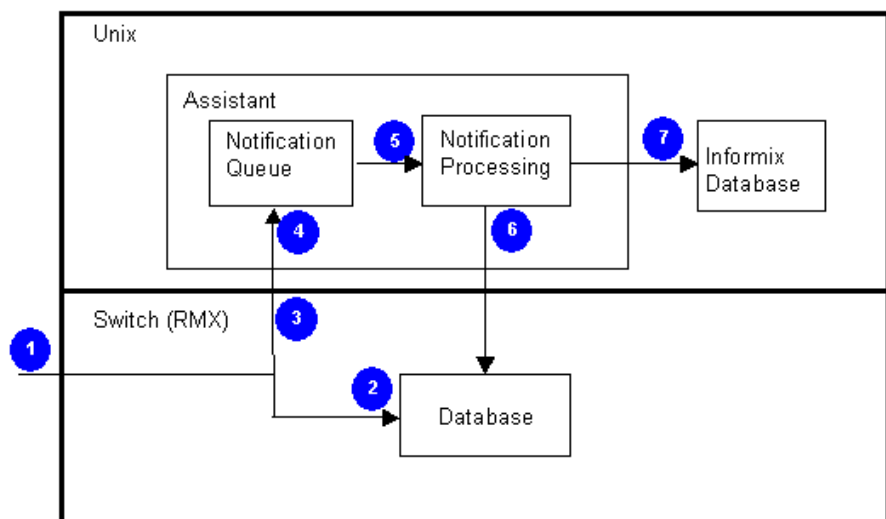

Figure 192: Notification Mechanism

13.4.1.2 AMO Commands Generated for Notifications

The OpenScope 4000 Assistant generates as few AMO commands as possible, only enough to retrieve the changes from the switches, but it also takes care of all ramifications of an AMO command. For example, if the user adds a new station (ADD-SBCSU), the OpenScope 4000 Assistant executes the following query AMO commands to update its database (the newly created station is the

first line, then comes the DIMEN counters, dial plans, PINs, etc., all related to that station):

```
EXEC-UPLO2:TYPE=PORT,STNO=<NUMBER>,DMSVER=V600;  
EXEC-UPLO2:TYPE=COSX,DMSVER=V600;  
EXEC-UPLO2:TYPE=DIMEN,DMSVER=V600;  
EXEC-UPLO2:DIMEN,V600;  
EXEC-UPLO2:DPLNET, <NUMBER>,,,,V600;  
EXEC-UPLO2:DPLN2, <NUMBER>,,,,V600;  
EXEC-UPLO2:DPLN1, <NUMBER>,,,V600;  
EXEC-UPLO2:PIN, <NUMBER>,,,V600;  
EXEC-UPLO2:DYNKEY, <NUMBER>,,V600;
```

13.4.1.3 Possible Sources of AMO Notifications

Any action that changes the switch database will generate notifications to the OpenScape 4000 Assistant. The most obvious source of database changes is direct AMO commands. A second source of AMO commands is the OpenScape 4000 Manager. All configuration changes executed on the OpenScape 4000 Manager are translated into AMO commands sent to the affected switches. These AMO commands result in notifications for the OpenScape 4000 Assistant. A third source of AMO commands are changes made from telephones, for example, fixed call forwarding, name key programming, etc. These changes have to be stored in the switch database. Therefore, the switch also sends notifications when they happen.

13.4.2 Networks without OpenScape 4000 Manager

IMPORTANT: Basic Usage Rule If the customer does not have OpenScape 4000 Manager, use the OpenScape 4000 Assistant to make configuration changes, not direct AMO commands.

You can find the following Frequently Asked Questions (FAQ) in this section:

- [What happens if I use AMO commands to change the switch configuration, bypassing the OpenScape 4000 Assistant?](#)
- [How long does it take to update the OpenScape 4000 Assistant database when an AMO command is executed?](#)
- [What will the user see on the OpenScape 4000 Assistant until the \(Informix\) database is updated?](#)
- [Does the OpenScape 4000 Assistant notify the users after updating its database?](#)
- [Does the notification process affect the OpenScape 4000 Assistant performance?](#)
- [Does the notification process slow down the execution of direct AMO commands?](#)
- [What happens if I execute a lot of AMO commands in a short period of time, e.g., run an AMO batch file?](#)
- [I have to execute a large AMO batch file to update a customer configuration. How should I proceed?](#)
- [Is there any automatic mechanism to synchronize the OpenScape 4000 Assistant database when it goes out of sync?](#)

What happens if I use AMO commands to change the switch configuration, bypassing the OpenScape 4000 Assistant?

The switch notifies the OpenScape 4000 Assistant that an AMO command (exactly which AMO command) was executed. The OpenScape 4000 Assistant retrieves the affected parts from the switch database and updates its database. To retrieve the affected parts, the OpenScape 4000 Assistant executes AMO commands (EXEC-UPLO2, REG-<AMO>, etc., depending on which AMO was executed). This notification process keeps the switch and the OpenScape 4000 Assistant databases in sync with each other. Refer to [Section 12.4.1, "The Notification Mechanism"](#) for a technical explanation of the notification mechanism.

How long does it take to update the OpenScape 4000 Assistant database when an AMO command is executed?

Anywhere from 30 seconds to 3 minutes. The time to update the database depends on:

- 1) what was changed on the switch (for example, deleting a station takes longer to finish than adding a firewall entry with AMO BDAT, because of all the possible side-effects of the station in the groups, routing, dial plan, etc.);
- 2) what the OpenScape 4000 Assistant is doing at the time. If it is processing a request from its users, it will first finish that request, and then it will process the notification;
- 3) the switch configuration (processor speed, number of processors, amount of RAM, etc.).

What will the user see on the OpenScape 4000 Assistant until the (Informix) database is updated?

The old data (before the AMO command was executed).

Does the OpenScape 4000 Assistant notify the users after updating its database?

No. If, for example, the user is looking at the configuration of station 2300 using the OpenScape 4000 Assistant, and in the meantime someone changes the configuration of that station using AMO commands, the OpenScape 4000 Assistant will update its database, but it will not tell the user that the database has been updated. The user is now looking at old data. If the user decides to make changes to this old data and save the changes, it will overwrite what has just changed on the switch. Note that this is no different from having two OpenScape 4000 Assistant users trying to work on the same station at the same time. This should never happen. An object should be modified from one place at a time only.

Does the notification process affect the OpenScape 4000 Assistant performance?

Yes. The OpenScape 4000 Assistant is able to process one request at a time. While the OpenScape 4000 Assistant is processing an AMO notification, it will not be able to process requests coming from its own user interface. In other words, a request coming from the OpenScape 4000 Assistant user will have to wait until the notification is processed. For the OpenScape 4000 Assistant user, it looks like the OpenScape 4000 Assistant is running slowly, when in fact the OpenScape 4000 Assistant is busy doing something else (the notification processing).

Does the notification process slow down the execution of direct AMO commands?

Yes. The switch can execute only one AMO command at a time. If the OpenScape 4000 Assistant is executing AMO commands to synchronize its database, AMO commands coming from other sources will have to wait their turn.

What happens if I execute a lot of AMO commands in a short period of time, e.g., run an AMO batch file?

There is a limited notification queue between the OpenScape 4000 Assistant and the switch (it can hold up to 25 AMO commands in its default configuration). If that notification queue overflows because the OpenScape 4000 Assistant cannot keep up with the AMO commands, the OpenScape 4000 Assistant will send a command to the switch to stop the AMO notifications and will put its database in out-of-sync state. Notifications will remain disabled until the next upload is executed from the OpenScape 4000 Assistant (either a manual upload or the nightly upload).

I have to execute a large AMO batch file to update a customer configuration. How should I proceed?

Do not use the OpenScape 4000 Assistant while the AMO batch file is running. If the AMO batch is large enough, it will eventually overflow the notification queue (see [What happens if I execute a lot of AMO commands in a short period of time, e.g., run an AMO batch file?](#)). This will stop the notification mechanism and put the OpenScape 4000 Assistant database in out-of-sync state. If you have to use the OpenScape 4000 Assistant immediately after executing the AMO batch file, run an upload. Otherwise, just wait for the nightly upload to do its job. In the next morning the OpenScape 4000 Assistant database should be synchronized with the switch database.

Is there any automatic mechanism to synchronize the OpenScape 4000 Assistant database when it goes out of sync?

Yes. Every night (at midnight, in the default configuration) the OpenScape 4000 Assistant synchronizes its database with the switch database. On a quiet system (with no activity between midnight and the next morning), the OpenScape 4000 Assistant database should always be in sync with the switch database in the morning.

13.4.3 Networks with OpenScape 4000 Manager

IMPORTANT: For information on networks with OpenScape 4000 Manager please refer to **OpenScape 4000 Manager V7, Installation and Service Manual, Service Documentation**.

Index

A

- AC-Powered OpenScape 4000 Cabinet 1 or 2
- Access Management [435](#)
- ACPCI [383](#)
- ACPCI-Hardware Variants
- ACPCI-Input Power Connectors [385](#)
- ACPCI-Input/Output Assignment [387](#)
- ACPCI-LED Indications [386](#)
- ACPCI-Removing the ACPCI [386](#)
- ACPCI-Replacing the ACPCI [386](#)
- ACPCI-Verifying the ACPCI [386](#)
- AP 3700-13 Shelf (OpenScape Host System) [153](#)
- AP 3700-13-Backplane Connections [33](#)
- AP 3700-13-Shelf Population (Back) with Patch Panels [32](#)
- AP 3700-13-Shelf Population (Back) without Patch Panels [32](#)
- AP 3700-13-Shelf Population (Front) [31](#)
- AP 3700-9-Backplane Connections [152](#)
- AP 3700-9-Shelf Population (Back) with Patch Panels [151](#)
- AP 3700-9-Shelf Population (Back) without Patch Panels [151](#), [153](#)
- AP 3700-9-Shelf Population (Front) [150](#)
- AP Emergency [34](#)

B

- BAM
 - AC-Powered OpenScape 4000 Cabinet 1 or 2
- Base Administration [436](#)
- Boards [156](#)

C

- Configuration Management [437](#)

D

- DCPCI [383](#)
- DCPCI-Hardware Variants
- DCPCI-Input Power Connectors [385](#)
- DCPCI-Input/Output Assignment [387](#)
- DCPCI-LED Indications [386](#)
- DCPCI-Removing the DCPCI [386](#)
- DCPCI-Replacing the DCPCI [386](#)
- DCPCI-Verifying the DCPCI [386](#)
- Diagnostics [437](#)
- DIU-N2 [167](#)
- DIU-N2-Board functions
- DIU-N2-Board Variants [168](#)
- DIU-N2-Configuring the board using AMOs [172](#)
- DIU-N2-Connecting Variants to DIU-N2 Ports [169](#)
- DIU-N2-Copper interface [169](#)
- DIU-N2-LED indications [168](#)

- DIU-N2-SIPAC connector pin assignments [170](#)
- DIU-N2-Sub-D Connectors X21 and X22 Pin Assignments [171](#)
- DIU-N2-Sub-D line interface connectors X23 and X24 Pin Assignments [171](#)
- DIU-N4 [167](#)
- DIU-N4-Board functions
- DIU-N4-Board Variants [168](#)
- DIU-N4-Copper interface [169](#)
- DIU-N4-LED indications [168](#)
- DIU-N4-Sub-D Connectors X21 and X22 Pin Assignments [171](#)
- DIU-N4-Sub-D line interface connectors X23 and X24 Pin Assignments [171](#)
- DIU2U [156](#)
 - Systems Supported [35](#)
- DIU2U-Configuring the board [160](#)
- DIU2U-Functional Description [157](#)
- DIU2U-Hardware [157](#)
- DIU2U-LED Indications [159](#)
- DIU2U-Removing the board [165](#)
- DIU2U-Replacing the board [166](#)
- DIU2U-Verifying the board [167](#)
- DIUT2
 - cable and connector assignment [38](#)
 - Replacing the board [44](#)
- DIUT2-Functional Description [35](#)

E

- EBCCB [400](#)
- Expert Mode [436](#)

H

- Hard Disk [431](#)
- Hardware Architecture Table [431](#)

I

- ICBP [409](#)
- Important Information [14](#)
- IP addresses
 - checking [419](#)
- IPDA-Equipment [149](#)

L

- L80XF-Replacing the L80XF Backplane [145](#)
- L80XF-Verifying the L80XF Shelf [145](#)
- LPC [402](#)
- LPC80 [387](#)
- LPC80-Connectors [392](#)
- LPC80-LED Indications [391](#)

- LPC80-Power Connection [388](#)
- LPC80-Power Supply Unit [388](#)
- LPC80-Removing the LPC80 [392](#)
- LPC80-Replacing the LPC80 [393](#)
- LPC80-Switches [392](#)
- LPC80-Verifying the LPC80 [393](#)
- LTUCA [173](#)
- LTUCA-Cable Types [174](#)
- LTUCA-Extended Shelves [174](#)
- LTUCA-Hardware Concept [175](#)
- LTUCA-Hardware Part Number [55](#), [174](#)
- LTUCA-LEDs [174](#)
- LTUCA-Power Supply [175](#)
- LTUW-Connectors [146](#)
- LTUW-Removing the LTUW Backplane [147](#)
- LTUW-Replacing the LTUW Backplane [147](#)
- LTUW-Verifying the LTUW Shelf [148](#)

M

- MCM
 - ALUM cable types [19](#)

N

- NCUI2+ [175](#)
- NCUI2+ Board Variants [176](#)
- NCUI2+ Interfaces [177](#)
- NCUI2+ LED Displays [177](#)
- NCUI2+ Modules [176](#)
- NCUI2+ Power Supply [178](#)
- NCUI2+ System Diagram [176](#)
- NCUI4 [183](#)
- NCUI4 Board Variants [184](#)
- NCUI4 board variants and modules [184](#)
- NCUI4 interfaces [184](#)
- NCUI4 LED Displays [184](#)
- NCUI4 LED displays and interfaces [184](#)
- NCUI4 modules [184](#)
- NCUI4 power supply [186](#)
- NCUI4 System Diagram [183](#)
- Notification Mechanism [438](#)

O

- ODP [411](#)
- OpenScape 4000
 - AC-Powered
 - Non-Redundant System (with L80XF Shelf) [382](#)
 - Redundant System (with LTUW Shelf) [383](#)
 - DC-Powered
 - Non-Redundant System (with L80XF Shelf) [382](#)
 - Redundant System (with LTUW Shelf) [383](#)
- OpenScape 4000 Assistant Applications [434](#)
- OpenScape 4000 in the customer LAN [419](#)

P

- PDPX2 [404](#)
- Portlist for Customer [431](#)
- Power FRUs [132](#)
- PSUP [393](#)
- PSUP-LED Indications [393](#)
- PSUP-Removing the PSUP [394](#)
- PSUP-Replacing the PSUP [395](#)
- PSUP-Verifying the PSUP [395](#)

R

- Ring Generator [190](#)
- Ring Generator-Jumper Setting for AC Generator [193](#)
- Ring Generator-Jumper settings for Ring Voltages [192](#)
- Ring Generator-LED Indications [191](#)
- Ring Generator-Module Types [191](#)
- Ring Generator-Removing the Ring Generator [193](#)
- Ring Generator-Replacing the Ring Generator [194](#)
- Ring Generator-Settings [191](#)
- Ring Generator-Verifying the Ring Generator [194](#)

S

- SHELF FRUs [31](#), [143](#)
- SIUX [194](#)
- SIUX-Removing the board [58](#)
- SIUX-Replacing the board [59](#)
- SIUX-Verifying the board [59](#)
- SIUX2 [194](#)
- SLC24 Subscriber Line CMI24 [194](#)
- SLC24-Block Diagram [198](#)
- SLC24-Interfaces [195](#)
- SLC24-LED Indications [195](#)
- SLC24-Power Supply [197](#)
- SLC24-X200 Board Layout [195](#)
- SLMA2 [198](#)
- SLMA2-Battery Supply [200](#)
- SLMA2-Connector Pin Assignment [203](#)
- SLMA2-Interface to the Administration [199](#)
- SLMA2-Interfaces [201](#)
- SLMA2-LED Indications [199](#)
- SLMA2-Power Supply Interface [200](#)
- SLMA2-Removing board [206](#)
- SLMA2-Replacing board [207](#)
- SLMA2-Verifying the board [207](#)
- SLMA3 [208](#)
- SLMA3-Country Spread [210](#)
- SLMA3-Functional Description [208](#)
- SLMA3-LED Indications [209](#)
- SLMA3-MDF Assignments [218](#)
- SLMA3-Removing the board [216](#)
- SLMA3-Replacing board [217](#)
- SLMA3-Verifying the board [218](#)
- SLMAC [219](#)
- SLMAC-Functional Description [219](#)

- SLMAC-LED Indications [222](#)
- SLMAC-MDF Assignments [224](#)
- SLMAC-Properties [222](#)
- SLMAC-Removing the board [223](#)
- SLMAC-Replacing board [64](#), [223](#), [229](#)
- SLMAC-Verifying the board [65](#), [224](#), [230](#)
- SLMAE [225](#)
- SLMAR [237](#)
- SLMAR-Backplane Pin Assignments [241](#)
- SLMAR-Feature Overview [237](#)
- SLMAR-Hardware Integrity [240](#)
- SLMAR-LED Indications [237](#)
- SLMAR-Subscriber Interface [238](#)
- SLMAV
 - Board [61](#)
- SLMO24 [243](#)
- SLMO24-Board Variants [244](#)
- SLMO24-LED Indications [244](#)
- SLMO24-MDF Assignments [247](#)
- SLMO24-Removing the board [245](#)
- SLMO24-Replacing the board [246](#)
- SLMO24-Verifying the board [246](#)
- SLMOP Digital Subscriber Line Circuit
 - UP0/E Interface
 - Improved Performance [248](#)
- SLMOP-Subscriber Line Module [249](#)
- SLMOP-UP0/E Interface [249](#)
- SLMQ [250](#)
- SLMQ-MDF Assignments [253](#)
- SLMQ-Removing the board [252](#)
- SLMQ-Replacing the board [252](#)
- SLMQ-UK0-2B1Q Interfaces [251](#)
- SLMQ-Verifying the board [253](#)
- SLMQ3-Functional Description [255](#)
- SLMQ3-LED Indications [256](#)
- SLMQ3-MDF Assignments [258](#)
- SLMQ3-Removing the board [256](#)
- SLMQ3-Replacing board [257](#)
- SLMQ3-SLMQ3 [254](#)
- SLMQ3-Verifying the board [257](#)
- Software Management [434](#)
- STHC [259](#)
- STHC-Board Variants [261](#)
- STHC-Feature Characteristics [259](#)
- STHC-UP0E Interface [260](#)
- STMA [261](#)
- STMA-Backboning feature [262](#)
- STMA-Connector [263](#)
- STMA-Features [262](#)
- STMA-Interworking feature [262](#)
- STMA-LED Indications [263](#)
- STMA-Removing the board [265](#)
- STMA-Replacing the board [266](#)
- STMA-Verifying the board [267](#)
- STMD [267](#)
- STMD-Board Functions [269](#)
- STMD-Configuring the board using AMOs [269](#)

- STMD-LED Indications [268](#)
- STMD-PIN Assignments [269](#)
- STMD2 [272](#)
- STMD2-LED Indications [75](#)
- STMD3 [272](#)
- STMD3-LED Indications [75](#)
- STMI2 (Q2316-X-*)-LED Displays [274](#)
- STMI2 (Q2316-X-*)Board Variants [274](#)
- STMI2 (S30810-Q2316-X-*) [273](#)
- STMI4 (Q2324-X-*) LED displays and interfaces [274](#)
- STMI4 (Q2324-X-*) system diagram [273](#)
- STMI4 (Q2324-X*) board variants and modules [274](#)
- STMI4 (Q2324-X*) interfaces [274](#)
- STMI4 (Q2324-X*) modules [274](#)
- System Management [437](#)

T

- TM2LP [276](#)
- TM2LP-Board Variants [277](#)
- TM2LP-Configuration Example for Switzerland [278](#)
- TM2LP-Loadware Variants [277](#)
- TM3WI [281](#)
- TM3WI-board variants [281](#)
- TM3WI-Calling Party Release Control (Unilateral LONIIS) [301](#)
- TM3WI-Calling party release control (Unilateral MGTS) [302](#)
- TM3WI-Connector Pin Assignments [293](#)
- TM3WI-First Party Release Control (MGTS) [299](#)
- TM3WI-Functions and Features for GUS [292](#)
- TM3WI-INLOC [302](#)
- TM3WI-Interfaces [293](#)
- TM3WI-Line Signaling Flow Diagrams [296](#)
- TM3WI-OTLOC [302](#)
- TM3WO [281](#)
- TM3WO-board variants [281](#)
- TM3WO-Calling Party Release Control (Unilateral LONIIS) [301](#)
- TM3WO-Calling party release control (Unilateral MGTS) [302](#)
- TM3WO-Connector Pin Assignments [293](#)
- TM3WO-First Party Release Control (MGTS) [299](#)
- TM3WO-Functions and Features for GUS [292](#)
- TM3WO-INLOC [302](#)
- TM3WO-Interfaces [293](#)
- TM3WO-Line Signaling Flow Diagrams [296](#)
- TM3WO-OTLOC [302](#)
- TMBD [309](#)
- TMC16 [311](#)
- TMC16-LED Indications [312](#)
- TMC16-MDF Assignments [314](#)
- TMC16-Removing the board [313](#)
- TMC16-Replacing the board [314](#)
- TMC16-Verifying the board [314](#)
- TMCOW [315](#)
- TMCOW-Call Charge Pulse Detection at 50 Hz [318](#)
- TMCOW-DIP-FIX Switches [317](#)

- TMCOW-LED Indications [317](#)
- TMCOW-Loadware Variants [318](#)
- TMCOW-Loop Grounding [318](#)
- TMCOW-Module Variants [316](#)
- TMDID [321](#)
- TMDID-MDF Assignments [324](#)
- TMDID-Removing the board [323](#)
- TMDID-Replacing the board [323](#)
- TMDID-Switches [322](#)
- TMDID-Verifying the board [324](#)
- TMDID2 [325](#)
- TMDID2 board
 - removing [332](#)
 - replacing [333](#)
 - verifying [334](#)
- TMDNH [334](#)
- TMDNH-Removing the board [336](#)
- TMDNH-Replacing the board [337](#)
- TMDNH-Verifying the board [337](#)
- TMEM [337](#)
- TMEM-Board Variants [338](#)
- TMEM-Carrier Frequenc [338](#)
- TMEM-Configuring the board on the Main PABX Circuit Using AMOs [339](#)
- TMEM-Configuring the board on the Satellite PABX Using AMOs [339](#)
- TMEM-Connectors [340](#)
- TMEM-Ear & Mouth Mode [338](#)
- TMEM-LED Indications [339](#)
- TMEM-MDF Punch-Down Assignments [342](#)
- TMEM-Removing the board [340](#)
- TMEM-Replacing the board [341](#)
- TMEM-Switches [340](#)
- TMEM-Verifying the board [341](#)
- TMEM-WTK 1 Mode [338](#)
- TMEMUS [342](#)
- TMEMUS-Functional Description [343](#)
- TMEMUS-LED Indications [339](#), [343](#)
- TMEMUS-MDF Assignments [348](#)
- TMEMUS-Removing the Board [346](#)
- TMEMUS-Replacing the board [347](#)
- TMEMUS-Verifying the board [348](#)
- TMEMW [342](#)
- TMEMW-Functional Description [343](#)
- TMEMW-LED Indications [343](#)
- TMEMW-MDF Assignments [348](#)
- TMEMW-Removing the Board [346](#)
- TMEMW-Replacing the board [347](#)
- TMEMW-Verifying the board [348](#)
- TMLBL [355](#)
- TMLBL-Adding Board Configuration Data [361](#)
- TMLBL-Configuring the board using AMOs [361](#)
- TMLBL-Functions [357](#)
- TMLBL-LED Indications [356](#)
- TMLBL-Loadware Variants [356](#)
- TMLBL-Push Buttons [356](#)
- TMLR [362](#)

- TMLR-DIP-FIX Switches [363](#)
- TMLR-LED Indications [362](#)
- TMLR-Signal Exchange [363](#)
- TMLRB [364](#)
- TMLRB-Board Variants [366](#)
- TMLRB-Key Indications [364](#)
- TMLRB-LED Indications [364](#)
- TMLRB-Loadware Variants [366](#)
- TMOM2 [367](#)
- TMOM2-Board Functions [367](#)
- TMOM2-Pin Assignments [371](#)
- TMSFP [372](#)
- TMSFP-Board Variants [372](#)
- TMSFP-DIP-FIX Switches [373](#)
- TMSFP-Key Indications [372](#)
- TMSFP-LED Indications [372](#)
- TMSFP-Loadware Variants [372](#)
- TMSFP-Transmission Parameters

U

- UACD [395](#), [395](#)
- UACD-ACDPX [396](#)
- UACD-BAM Connectors
- UACD-LPC Connectors
- UACD-LPC LED Indications
- UACD-PDPX2 Circuit Breakers
- UACD-PDPX2 Connectors
- UACD-Removing the ACDPX
- UACD-Removing the BAM
- UACD-Removing the LPC
- UACD-Removing the PDPX
- UACD-Replacing the ACDPX
- UACD-Replacing the BAM
- UACD-Replacing the PDPX2
- UACD-Verifying the ACDPX
- UACD-Verifying the BAM
- UACD-Verifying the LPC
- UACD-Verifying the PDPX2
- UDCD [142](#)
- UDCD- ICPB Switches
- UDCD-ICBP Connectors
- UDCD-ODP Connectors
- UDCD-ODP Jumpers
- UDCD-ODP Switches
- UDCD-Removing the ICBP
- UDCD-Removing the ODP
- UDCD-Removing the ZYT
- UDCD-Replacing the ICBP
- UDCD-Replacing the ODP
- UDCD-Replacing the ZYT
- UDCD-Verifying the ICBP
- UDCD-Verifying the ODP
- UDCD-Verifying the ZYT
- UDCD-ZYT Connectors
- UDCD-ZYT LED Indications
- Usage Scenarios [438](#)

User Accounts [438](#)

V

VCM Voice Compression [375](#)

VCM-Activating Voice Compression [377](#)

VCM-Administering More Data Channels or More Voice Channels [382](#)

VCM-Compression

Outgoing [379](#)

VCM-Configuring the board using AMOs [377](#)

VCM-Configuring the Shelves [377](#)

VCM-Deactivating Voice Compression [377](#)

VCM-Decompression

Incoming [379](#)

VCM-Mixed Mode Operation

Voice and Data [381](#)

VCM-Switching Boards and Circuits [377](#)

VCM-Transit Connections [380](#)

Z

ZYT [414](#)

