



A MITEL  
PRODUCT  
GUIDE

# Unify OpenScape 4000

Initial Installation

Installation Instructions

11/2025

## Notices

The information contained in this document is believed to be accurate in all respects but is not warranted by Mitel Europe Limited. The information is subject to change without notice and should not be construed in any way as a commitment by Mitel or any of its affiliates or subsidiaries. Mitel and its affiliates and subsidiaries assume no responsibility for any errors or omissions in this document. Revisions of this document or new editions of it may be issued to incorporate such changes. No part of this document can be reproduced or transmitted in any form or by any means - electronic or mechanical - for any purpose without written permission from Mitel Networks Corporation.

## Trademarks

The trademarks, service marks, logos, and graphics (collectively "Trademarks") appearing on Mitel's Internet sites or in its publications are registered and unregistered trademarks of Mitel Networks Corporation (MNC) or its subsidiaries (collectively "Mitel), Unify Software and Solutions GmbH & Co. KG or its affiliates (collectively "Unify") or others. Use of the Trademarks is prohibited without the express consent from Mitel and/or Unify. Please contact our legal department at [iplegal@mitel.com](mailto:iplegal@mitel.com) for additional information. For a list of the worldwide Mitel and Unify registered trademarks, please refer to the website: <http://www.mitel.com/trademarks>.

© Copyright 2025, Mitel Networks Corporation

All rights reserved

# Contents

<b>1 Introduction and Important Notes.....</b>	<b>9</b>
1.1 Product Overview.....	9
1.2 Target Group and Requirements.....	9
1.3 Using this Manual.....	9
1.3.1 Notational Conventions Used.....	9
1.4 Safety Information and Warnings.....	10
1.4.1 Warning Sign: Danger.....	11
1.4.2 Warning Sign: Warning.....	11
1.4.3 Warning Sign: Caution.....	12
1.4.4 Important Information.....	13
1.5 Emergencies.....	14
1.6 Reporting Accidents.....	14
1.7 Normal Use.....	15
1.8 Proper Disposal and Recycling.....	15
1.9 Standards and Guidelines on Installation.....	15
1.9.1 Connection to the Power Supply.....	15
1.9.2 Fire Safety Regulations.....	16
1.9.3 Screened Lines for LAN, WAN, and DMZ Connections.....	16
1.9.4 Labeling.....	17
1.10 Data Protection and Data Security.....	17
1.11 Documentation Feedback.....	18
<b>2 System Overview.....</b>	<b>19</b>
2.1 OpenScape 4000 IP Distributed Architecture.....	19
2.2 OpenScape 4000 Hardware.....	20
2.2.1 OpenScape EcoServer.....	21
2.2.2 Access Point AP3700 (Host Shelf).....	22
2.2.3 Available interface cards.....	24
2.2.4 OpenScape Enterprise Gateway.....	28
2.2.5 OpenScape EcoBranch.....	29
2.2.6 OpenScape Access Modules.....	29
2.2.7 Main Distribution Frame / Cabling.....	31
<b>3 Preparing for Installation.....</b>	<b>34</b>
3.1 Work steps.....	34
3.2 Installation Materials.....	37
3.3 Conducting the Site Verification.....	37
3.4 Unpacking and checking the delivery.....	37
3.5 Important Labels on the System.....	38
3.6 Installing Seismic Anchors.....	40
3.7 Stacking OpenScape 4000 Cabinets.....	41
3.8 Installing the Cable Channels.....	42
<b>4 Installation.....</b>	<b>43</b>
4.1 Installing the OpenScape EcoServer/EcoBranch.....	43
4.1.1 Pre-assembling the Adapter Frame (Simplex).....	43
4.1.2 Installing the Adapter Frame.....	45
4.1.3 Installing Lower Air Baffles.....	45
4.1.4 Installing the EcoServer.....	47
4.1.5 Installing the DCDR.....	47
4.2 Installing AP 3700 Cabinets in 19-Inch Cabinets.....	48
4.3 Removing / Installing Boards.....	50

## Contents

4.3.1 SIVAPAC-to-SIPAC Adapter.....	50
4.4 Installing Shielding Covers.....	52
4.5 Replacing the CSPCI/CCDAX in the 30" Shelf with an EcoServer.....	53
4.5.1 Removing the CSPCI/CCDAX Shelf.....	54
4.5.1.1 Removing the CSPCI Shelf.....	54
4.5.1.2 Removing the CCDAX Shelf.....	55
4.6 Shielding Connection on the Opening of the LTU Frame.....	57
4.7 Attaching the Ferrite.....	57
4.7.1 Attaching the Ferrite Core to the AC Mains Cable.....	58
4.7.2 Attaching the Ferrite Core to the DC Cables.....	60
4.7.3 Description and Handling of Ferrite Core.....	63
<b>5 Installation Variants.....</b>	<b>65</b>
5.1 30" Standard Cabinet Installation.....	65
5.1.1 Single-Cabinet Installation.....	65
5.2 Multiple Cabinet Installation.....	66
5.3 AC-to-DC Power Box Installation.....	67
5.4 DC-to-DC Power Box Installation.....	67
5.5 Free-Standing Installation.....	68
5.5.1 CSPCI Box/EcoServer in UCS Shelf, Stack 1.....	68
5.5.2 CSPCI Box/EcoServer in External 19" Cabinet.....	69
5.5.3 OpenScape 4000 Free-Standing Installation (30" Maximum Configuration).....	70
5.6 Cabling Diagram, I.M.....	71
5.7 Shelf Configuration.....	71
5.7.1 EcoServer.....	71
5.7.1.1 Standalone Installation.....	73
5.7.1.2 19" Installation.....	74
5.7.1.3 30" Installation.....	75
5.7.2 UPR Cabinet.....	76
5.7.3 Unit Peripheral Nonredundant Cabinet.....	76
5.7.4 AP 3700-9.....	76
5.7.5 AP 3700-13 (Expansion Cabinet).....	79
5.7.6 Redundant Power Box Stacks.....	81
5.8 Installation with AP 3700 Cabinets.....	82
5.8.1 Connecting AP 3700-9 to L80XF/LTUW.....	82
5.8.2 Connecting AP 3700-13 to CSPCI/EcoServer.....	82
5.8.3 AP 3700 Configuration Rules and Examples with 19" Cabinets/Open Racks.....	82
5.8.3.1 Suitable Cabinet Models.....	83
5.8.3.2 Sample Configuration AP 3700 or AP3700 IP in a Cabinet with 25 Rack Units.....	85
5.8.3.3 Sample Configuration CSPCI with AP 3700 in a Cabinet with 37 Rack Units.....	86
5.8.3.4 Sample Configuration CSPCI with AP 3700 in a Cabinet with 42 Rack Units.....	87
5.8.3.5 Sample Configuration CSPCI with AP 3700 in a Cabinet with 47 Rack Units.....	88
5.9 MDFHX 6 Mounting Location, I.M.....	89
5.10 MDFHX 8 Mounting Location, I.M.....	90
<b>6 Grounding the OpenScape 4000.....</b>	<b>91</b>
6.1 Grounding the Main Distribution Frame (MDF).....	91
6.2 Connecting and Grounding the Boxes in the 30" Cabinet.....	92
6.2.1 Grounding the Base Cabinets.....	93
6.2.2 Installing the Ground Straps Between Cabinets.....	93
6.3 Grounding the System (30" cabinet).....	94
6.4 Grounding AP 3700 System Cabinets.....	95
6.5 System Ground Connections (19" variant).....	96
6.5.1 Ground Pattern for 19" AC Connection.....	97
6.5.2 Ground Pattern for 19" DC Connection.....	98
6.5.3 Ground Pattern for AC Standalone.....	99

6.5.4 Ground Pattern for DC Standalone.....	100
<b>7 Connecting to the Mains and Power Supply.....</b>	<b>102</b>
7.1 Connecting to the Mains.....	102
7.1.1 Connecting to the Mains with LUNA/LPC80 Power Supply Units.....	103
7.1.2 Connecting to the Mains Using the Power Box.....	105
7.2 Installing a Three-Phase Network.....	106
7.3 Installing a Single-Phase Network.....	107
7.4 Overview of Mains Connection 1 .....	108
7.5 Installing a Three-Phase or Single-Phase Connection with Mid-Point Grounding, I.M.....	108
7.6 Overview of Mains Connection 2, I.M.....	110
7.7 Power Supply.....	110
7.8 AC Connection to Power Supplies.....	111
7.8.1 Routing the Power Cables on an AC-Powered, Nonredundant OpenScape 4000.....	111
7.8.2 Attaching the Power Cable to the CSPCI Box.....	112
7.8.3 AC connection with UP/L80XF cabinet + battery backup (non-redundant).....	113
7.8.4 Connecting the Mains Cable to the EcoServer.....	114
7.9 Setting the Operating Mode for the LPC80, I.M.....	115
7.9.1 Setting the Operating Mode.....	115
7.10 DC Connection with the External Power Supply, I.M.....	116
7.10.1 Routing the Power Cables on an AC-Powered, Redundant OpenScape 4000.....	117
7.10.2 Routing the Power Cables from the UACD and UDCD to the OpenScape 4000.....	118
7.10.3 Attaching a DC Cable to the CSPCI Box.....	118
7.10.4 Connecting the DC Cable to the EcoServer.....	121
7.11 DC Connection with UP/L80XF Cabinet, I.M.....	122
7.12 AC-to-DC Connection with a Redundant LTUW Cabinet.....	123
7.13 DC Connection with Redundant UPR/LTUW Box, I.M.....	124
7.13.1 Connecting the Battery to the Power Box, I.M.....	125
7.13.2 Connecting the MDF for a Non-redundant, System, I.M.....	126
7.14 AC-to-DC Connection with AP 3700.....	127
7.14.1 AC Connection AP 3700-9/AP 3700-13.....	128
7.14.2 DC Connection AP 3700-9/AP 3700-13.....	128
7.14.3 AC Connection AP 3700 in 19" Cabinet.....	129
7.14.4 DC Connection AP 3700 with DCDR (Fuse Unit).....	130
7.14.5 DC Connection AP 3700 with DCDR (DC Kit for 19-Inch Cabinet).....	132
7.14.6 DCDR Connection from Behind.....	133
7.14.7 DC Connection of AP 3700 to the MDF.....	135
7.14.8 Earth and 0 V power rating - for stacking.....	137
7.15 UACD (GE) 19-Inch Installation.....	137
7.15.1 Connect the power supply to an UACD.....	139
7.15.1.1 Install Primary Shelf A.....	139
7.15.1.2 Install Secondary Shelf B - Two shelf System.....	143
7.15.1.3 Shelf to shelf communication (Required only in two shelf systems).....	146
7.15.1.4 Install DC load output cables.....	147
7.15.1.5 Thermal Probes.....	150
7.15.2 Alarm Outputs.....	153
7.15.3 UACD Power Box Part Numbers.....	154
7.15.4 AC/DC Connection - Cabinet variants.....	155
7.15.4.1 AC/DC Connection UACD with AP3700.....	156
7.15.4.2 AC/DC Connection UACD with UPR/LTUW".....	157
7.15.4.3 UACD Cable list.....	157
7.15.5 Mains Connection Variants for UACD.....	158
7.15.6 Connecting a Battery to the UACD.....	161
7.15.7 UACD Additional informations.....	162
7.16 UACD (GE) 30-Inch Installation (for upgrade installations only).....	163
7.16.1 Kit C39165-A7080-B177-1 " Components to be used on the Front side.....	164

## Contents

7.16.2 Kit C39165-A7080-B176-1 “ Components to be used on the Back side.....	165
7.16.3 Mounting Guideline for Two Shelves 30 Inch Step by step.....	166
7.17 UACD (PSR930/PSR930E) 19-Inch Installation.....	187
7.17.1 UACD Power Box Part Numbers (PSR930/PSR930E).....	189
7.17.2 AC/DC Connection with UACD (PSR930/PSR930E) in 19" Cabinet with AP3700.....	190
7.17.3 AC/DC Connection - SAPP Boxes (from HP4 V2.0) with Ecoserver and UACD from GE in 19" Cabinet.....	191
7.17.4 AC/DC Connection with UACD (PSR930/PSR930E) in 19" Cabinet with UPR/LTUW.....	192
7.17.5 Stacking construction (up to HP4 V2.0) with UACD NEW in 19" Cabinet with UPR/LTUW periph.....	193
7.17.6 Mains Connection Variants for UACD (PSR930/PSR930E).....	194
7.17.6.1 Installing a Three-Phase Network.....	194
7.17.6.2 Installing a Single-Phase Network.....	194
7.17.6.3 Installing a Two-Phase Network.....	195
7.17.6.4 Installing a Mains Delta Connection.....	195
7.17.7 Connecting a Battery to the UACD (PSR930/PSR930E).....	196
7.18 UACD (with BAMX1 and BAMX2) 30-Inch Installation.....	196
7.18.1 UACD Equipment Part Numbers.....	197
7.18.2 UACD 1 Connections.....	198
7.18.3 UACD 2 Connections.....	199
7.19 Battery Manager Cabinet for L80XF Shelf.....	200
7.19.1 Part Numbers for Battery Manager Cabinet.....	200
7.19.2 Battery Manager, Connection Configurations.....	201
7.20 UDCD (Zytron), North America Only.....	202
7.20.1 UDCD Equipment Part Numbers, North America Only.....	202
7.20.2 Overview of UDCD stack 1 connections.....	203
7.21 UDCD (Lineage Power).....	203
7.22 Connecting the Power Box to the System.....	204
7.22.1 Connecting the MDF for a Redundant System, I.M.....	205
7.23 PSDXE Connection.....	205
7.24 Calculating the Battery Cabling, I.M.....	206
<b>8 Internal Line Cables.....</b>	<b>208</b>
8.1 Installing Signal Cables.....	208
8.1.1 Overview of EcoServer (RTMx) Connection to L80XF/LTUW/AP 3700 (LTUCA Board).....	210
8.1.2 Overview of CSPCI Periphery Connections.....	211
8.1.3 Overview of EcoServer Periphery Connections.....	212
8.1.3.1 Front.....	212
8.1.3.2 Back.....	213
8.1.4 Replacing Cross-Connect Cables.....	214
8.1.4.1 Application 1: A server in the duplex system is defective:.....	214
8.1.4.2 Application 2: Replacing the cross-connect cable / operation without cross-connect cable:.....	214
8.1.4.3 Application 3: Switching from standalone to duplex:.....	214
8.2 Installing the Service Alarm Cable and Trunk Bypass.....	215
<b>9 External Cabling Assemblies.....</b>	<b>216</b>
9.1 MDFHX6 Assembly, I.M.....	216
9.1.1 Cabling from the LTU to the MDF, I.M.....	217
9.1.2 Cable Routing from AP 3700-13 Cabinet to the MDF, I.M.....	218
9.2 Overvoltage Protection of the Modules, I.M.....	218
9.3 MDF Cable Connections, I.M.....	219
9.4 Connecting the Signal or Alarm Cables to the MDF, I.M.....	220
9.5 Connecting Subscriber Line Modules/Trunk Boards.....	222
9.5.1 Subscriber-Line Module Boards.....	222
9.5.1.1 Connecting the Subscriber Line Modules.....	223
9.5.2 Trunk Module Part Numbers.....	227
9.5.2.1 Connecting the Trunk Modules to the MDF.....	229

9.5.2.2 Connection to MDF with DID.....	231
9.5.2.3 Connecting to the MDF with CDR and DID.....	233
9.5.2.4 Connecting to the MDF with CDR but without DID.....	234
9.6 Creating a Strapping List, I.M.....	236
9.6.1 System Assignment 16/24 DA Splitting Strip.....	236
9.6.2 Network Assignment 25/35 DA Strapping Connector.....	238
<b>10 Installing Peripheral Equipment.....</b>	<b>241</b>
10.1 Installing the AC-WIN IP Attendant Console.....	241
10.2 Connecting the Service Terminal.....	242
10.3 HiPath SIRA (Secured Infrastructure For Remote Access).....	243
10.4 Connecting Cables.....	243
10.4.1 Connecting ISDN Connections.....	243
10.4.1.1 PNE/PBXXX Back-to-Back with Modem and DIUT2.....	244
10.4.1.2 PNE/PBXXX Back-to-Back with DIUT2.....	245
10.4.1.3 PNE/PBXXX Back-to-Back with Modem in DIUS2 Emulation with DIUT2.....	246
10.4.1.4 PBXXX as Gateway, Fully Integrated Mode.....	247
10.4.1.5 PBXXX with DIUT2 as Gateway, Partially Integrated Mode.....	247
10.5 Installing the Distance Adapter.....	247
<b>11 Installing the IPDA.....</b>	<b>250</b>
11.1 IPDA Connection Variants.....	251
11.1.1 Connecting to AP 3700-9 IP.....	251
11.1.2 Connecting to LTUW/L80XF.....	252
<b>12 Starting the System.....</b>	<b>253</b>
12.1 Completing the Installation.....	253
12.2 Pre-Power On Checks.....	253
12.2.1 Reseating the Boards.....	254
12.2.2 Checking the Signal Cable Connections.....	254
12.2.3 Checking the Power Distribution Cable Connections.....	254
12.3 Turning on a Nonredundant AC-Powered OpenScope 4000.....	254
12.4 Turning on Cabinet 1 and 2 of a Redundant AC-Powered OpenScope 4000.....	255
12.5 Turning on Cabinet 3 and 4 of a Redundant AC-Powered OpenScope 4000.....	255
12.6 Turning on Cabinet 1 of a DC-Powered OpenScope 4000.....	256
12.7 Turning on Cabinet 2 of a DC-Powered OpenScope 4000.....	257
12.8 Turning on Cabinet 3 of a DC-Powered OpenScope 4000.....	258
12.9 Turning on Cabinet 4 of a DC-Powered OpenScope 4000.....	258
12.10 Setting the Date and Time.....	258
12.11 Installation Processes.....	259
12.12 Starting the System.....	259
12.13 Replacing the Covers.....	259
<b>13 Verifying the System.....</b>	<b>261</b>
13.1 Tools Required.....	261
13.2 Checking the Boards.....	261
13.3 Checking the Cables.....	261
13.4 Checking and Testing the Features.....	262
13.5 Testing the Restart and Failure Transfer Function.....	262
13.6 Backing up the Customer Data.....	262
13.7 Setting and Activating the SIRA Function.....	262
13.8 Checking the Ring Generator.....	263
13.9 Verifying the Station-to-MDF Connections.....	263
13.10 Verifying Transmission Facilities.....	263
13.10.1 Balancing Networks.....	263
13.10.2 Choosing the Balance Network.....	264
13.10.3 Selecting the Balance Network.....	264

Contents

- 13.10.3.1 Balancing CO Trunks.....265
- 13.10.3.2 Balancing DID Trunks.....266
- 13.10.3.3 Balancing OPS Lines and Trunks..... 267
- 13.10.4 Verifying ISDN Spans..... 268
- 13.10.5 Verifying T1 Spans.....270
- 13.10.6 Recording Circuit IDs..... 272
- 13.11 Verifying the Hard Disk.....272
- 13.12 Verifying the Operation of System Features and Servers.....272
  - 13.12.1 Testing CDR..... 272
  - 13.12.2 Testing Least-Cost Routing.....273
- 13.13 Verifying the System Bypass.....275
- 13.14 Customer Training, I.M..... 275
- 14 Adding Cabinets to the System.....276**
  - 14.1 Expansion Configuration.....276
  - 14.2 Connecting the Cabinet Stacks.....277
- Index..... 278**

# 1 Introduction and Important Notes

## 1.1 Product Overview

OpenScope 4000 provides hybrid IP communication solutions for companies with 300 up to 100.000 users in a corporate communication network.

The solution offers the maturity and broad range of enterprise-grade features with a high reliable SW-architecture and security functionalities. It combines the advantages of both worlds with networking, with carrier access and the flexible connection of analog, TDM- and IP-phones, mobile WLAN- and DECT devices and soft clients.

## 1.2 Target Group and Requirements

These installation instructions are aimed at service engineers, startup specialists and self-maintainers.

Basic knowledge of telecommunications and OpenScope 4000 is required for setting up and installing the communication system.

## 1.3 Using this Manual

### 1.3.1 Notational Conventions Used

This manual uses the following notational conventions:

Purpose	Style	Example
Special emphasis	Boldface	Name must not be deleted.
User interface elements	Boldface	Click OK.
Menu sequence	>	File > Close
Textual cross-references	Italics	For more information, see Network.
Output	Font with a fixed width such as Courier	Command not found.
Input	Font with a fixed width such as Courier	Enter LOCAL as the file name.

Purpose	Style	Example
Key combinations	Font with a fixed width such as Courier	<CTRL>+<ALT>+<ESC>
Steps and subordinate steps in instructions	Numbered lists (using numbers and letters)	Set up the DSL telephony subscriber with the corresponding extension number. Click Add. In DSL Telephony Subscriber, enter the name of the DSL telephony subscriber.
Options in instructions	Bulleted list	If you want to output amounts, select the Output Amounts, Not Units checkbox. If you want to output units, deselect the Output Amounts, Not Units checkbox.

---

**IMPORTANT:** Identifies useful information.

---

## 1.4 Safety Information and Warnings

Work on communication systems and devices may **only** be carried out by qualified persons.

For the purposes of safety information and warnings, qualified persons are persons who are authorized to place into operation, ground, and label systems, devices, and lines in accordance with applicable safety procedures and standards.

It is absolutely essential that you read and understand the following safety information and warnings before starting installation and implementation work on the communication system or device.

You should also carefully read and observe all safety information and warnings on the communication systems and devices themselves.

Familiarize yourself with emergency numbers.

Always consult your manager before starting work in conditions where the necessary safety precautions do not appear to be in place.

### Types of safety information and warnings

The following grades of safety information/warnings are used in this manual:



**DANGER:** Indicates an immediate danger that could result in death or serious injury.



**WARNING:** Indicates a general danger that could result in death or serious injury.



**CAUTION:** Indicates a danger that could result in injury.

---

**NOTICE:** Indicates situations that could result in damage to property and/or loss of data.

---

#### Symbols for specifying the source of danger more exactly

The following symbols are not usually used in the manual. They explain symbols that may be depicted on the communication systems and equipment.



Electricity



Weight



Heat



Fire



Chemicals

\* electrostatically sensitive devices

### 1.4.1 Warning Sign: Danger



**DANGER:** Risk of electric shock through contact with live wires

---

- Note: Voltages above 30 Vac (alternating current) or 60 Vdc (direct current) are dangerous.
- Only personnel with proper qualifications or qualified electricians should perform work on the low-voltage network (<1000 Vac) and all work must satisfy national/local requirements for electric connectors.

### 1.4.2 Warning Sign: Warning

#### Risk of electric shock through contact with live wires

An electric shock can be life-threatening or lead to serious injuries such as burns.

There are additional dangers even when working with low voltage and large cable cross-sections. Cables with a large cross-section generally have lower voltages, although the amperages are higher.

- Before starting any work, check that the circuits involved are de-energized. Never take it for granted that turning off a main switch or circuit breaker will reliably interrupt all circuits.
- Only use systems, tools, and equipment which are in perfect condition. Do not use equipment with visible damage.
- Replace any damaged safety equipment (covers, labels and ground wires) immediately.
- Replace the power cable immediately if you notice any damage.
- Only place systems or devices in protection class I into operation using a ground contact socket.

## Introduction and Important Notes

- Connect the communication system and, if necessary, the main distribution frame to the ground wire before starting up the system and connecting telephones and lines. Never operate the communication system without the required ground wire.
- Never touch live wires without ensuring adequate insulation.
- Do not carry out any hardware installation work on communication systems and devices during a storm.
- Expect leakage current from the communications network. Disconnect all communication lines from the system before disconnecting the prescribed ground wire from the system.

### Disconnection from power circuit(s)

A disconnect device can be a disconnecting switch (main switch), circuit breaker (fuse/cutout), or power plug that completely disconnects the communication system and device from the power circuit.

- Before carrying out any work on the communication system or on the device, find out whether there is a disconnect device and locate it.
- When you need to disconnect the power supply to the communication system or device, you do so using the disconnect device.
- Secure the disconnect device mechanically so that it cannot be used by other persons and attach a sign reading DO NOT OPERATE to the disconnect device.
- Disconnect all power supply circuits if the communication system's power supply unit is not needed for certain work (for example, when changing cables). Disconnect the communication system's power plug and ensure that the communication system or device is not powered from an additional power source (for example, an uninterruptible power supply), or that it is protected by an additional fuse or an additional main switch.
- If you are performing work on circuits with hazardous voltages, always work together with a partner who is familiar with the location of the disconnect devices for the power supplies.
- Always disconnect the power supply when you are working directly next to a power supply unit or direct current converter, unless the work instructions expressly permit you to work without disconnecting the power supply.
- As long as the power supply is switched on, always observe the greatest caution when performing measurements on powered components and maintenance work on plug-in cards, PC boards and covers.
- Metallic surfaces such as mirrors are conductive. If you touch them, there is a risk of electric shocks or short circuits.

### 1.4.3 Warning Sign: Caution



---

#### **CAUTION: Danger of injury:**

---

- When working on an open communication system or device, make sure that it is never left unattended.
- Risk of injury resulting from heavy items or loads. Lifting heavy objects/loads can cause injury. Use appropriate aids to carry out such tasks.
- Risk of injury resulting from laser radiation. If there are any optical interfaces: In case of laser radiation, do not look directly into the beam. You could damage your eyes.



**CAUTION: Risk of explosion if accumulators and batteries are not changed properly:**

- 
- Only use licensed battery packs and batteries.
  - The lithium battery must be replaced only by an identical battery or one recommended by the manufacturer.
- 



**CAUTION: Risk of fire:**

- 
- Only communications cables with a cable diameter of at least 0.4 mm (AWG 26) or larger may be used.
  - The system cabinets must not be fitted with any third-party devices that have not been approved.
  - Do not store any documents or similar flammable items in the system.
- 



**CAUTION: General risk of injury/accidents in the workplace:**

- 
- When maintenance work has been completed, always re-install all safety equipment in the right place. Also close all doors, covers, or the housing after completing test and maintenance work.
  - Lay cables so as to prevent any risk of them being damaged or causing accidents, such as tripping.
  - Make sure that the work area is well lit and tidy.
  - When working on the communication system, never wear loose clothing and always tie back long hair.
  - Do not wear jewelry, metal watchbands or clothes with metal ornaments or rivets. There is a risk of injury and short circuits.
  - Always wear the necessary eye protection whenever appropriate.
  - Always wear a hard hat where there is a risk of injury from falling objects.
  - Check your tools regularly. Only use intact tools.

## 1.4.4 Important Information

Note the following information in order to avoid damage to property:

- Before placing the system into operation, check whether the nominal voltage of the power supply network corresponds to the nominal voltage of the communication system or device (type plate). If necessary, adjust the nominal voltage of the communication system or device appropriately.
- Protection of electrostatically sensitive devices (ESD):
  - Always wear the wristband in the prescribed manner before performing any work on PC boards and modules.
  - Transport PC boards and modules only in suitable protective packaging.
  - Always place PC boards and modules on a grounded conductive base, and do not work on the PC boards anywhere else.
  - Only use grounded soldering irons.
- Use only original accessories. Failure to comply with this safety information may damage the communication system or violate safety and EMC regulations.

## Introduction and Important Notes

### Emergencies

- Before starting wall assembly, check that the load-bearing capacity of the wall is adequate, Always use suitable installation and fixing material to make sure that the communication system is mounted safely.
- Condensation damage: If the temperature changes rapidly, air humidity can precipitate. If the communication system or device is moved from a colder to a warmer environment, moisture can precipitate. Wait until the temperature has adjusted to the ambient temperature and the communication system or device is completely dry before starting it up.
- If there is no emergency power supply available or if switchover to analog emergency phones is not possible during a power failure, no more emergency calls can be made via the communication system if the power supply unit fails.

## 1.5 Emergencies

### What to do in an emergency

- In the event of an accident, remain calm and controlled.
- Always switch off the power supply before you touch an accident victim.
- If you are not able to immediately switch off the power supply, only touch the victim with non-conductive materials (such as a wooden broom handle), and first of all try to isolate the victim from the power supply.

### First aid

- Be familiar with basic first aid procedures for electrical shock. A fundamental knowledge of the various resuscitation methods if the victim has stopped breathing or if the victim's heart is no longer beating, as well as first aid for treating burns, is absolutely necessary in such emergencies.
- If the victim is not breathing, immediately perform mouth-to-mouth or mouth-to-nose resuscitation.
- If you have appropriate training, immediately perform heart massage if the victim's heart is not beating.

### Calling for help

- Immediately call an ambulance or an emergency physician. Provide the following information in the following sequence:
  - Where did the accident happen?
  - What happened?
  - How many people were injured?
  - What type of injuries?
  - Wait for questions.

## 1.6 Reporting Accidents

- Immediately report all accidents, near accidents and potential sources of danger to your manager.
- Report all electric shocks, no matter how small.

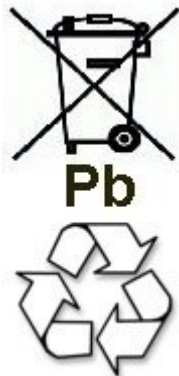
## 1.7 Normal Use

The communication system may only be used for the applications described in this documentation and only in conjunction with add-on devices and components recommended and approved by Unify GmbH & Co. KG. The prerequisites for the normal use of the communication system include appropriate transport, storage, installation and startup as well as meticulous operation and maintenance.

## 1.8 Proper Disposal and Recycling

All electrical and electronic products should be disposed of separately from the municipal waste stream via designated collection facilities appointed by the government or the local authorities. The correct disposal and separate collection of your old appliance will help prevent potential negative consequences for the environment and human health. It is a precondition for reuse and recycling of used electrical and electronic equipment. For more detailed information about disposal of your old appliance, please contact your city office, waste disposal service, the shop where you purchased the product or your sales representative. The statements quoted above are only fully valid for equipment which is installed and sold in the countries of the European Union and is covered by the directive 2002/96/EC. Countries outside the European Union may have other regulations regarding the disposal of electrical and electronic equipment.

Used accumulators and batteries with this sign are valuable economic goods and must be recycled. Used accumulators and batteries that are not recycled must be disposed of as hazardous waste with full observance of all regulations.



## 1.9 Standards and Guidelines on Installation

### 1.9.1 Connection to the Power Supply

OpenScape communication systems are approved for connection to TN-S power supply systems. They can also be connected to a TN-C-S power supply system in which the PEN conductor is divided into a ground wire and a neutral wire. TN-S and TN-C-S systems are defined in the IEC 364-3 standard.

## Introduction and Important Notes

If work on the low-voltage network is required, it must be carried out by a qualified electrician. The installation work required to connect OpenScape communication systems must be carried out with full observance of IEC 60364 and IEC 60364-4-41 or the equivalent legal norms and national regulations (in the U.S. and Canada, for example).

### 1.9.2 Fire Safety Regulations

Fire safety regulations are specified in country-specific building codes. Adhere to the relevant regulations.

To conform with the legal fire protection and EMC requirements, operate the OpenScape systems only when closed. You may open the system only briefly for assembly and maintenance work.

As regards their burning behavior, OpenScape system cables conform to the international standard IEC 60332-1. The following standards include equivalent requirements regarding the burning behavior of cables.

IEC 60332-1 -----	EN 50265-1 with EN 50265-2-1 -----	VDE 0482 parts 265-1 with VDE 0842 parts 265-2-1 -----
Note: IEC 60332-1 corresponds to UL VW-1	Note: EN 50265-1 and -2-1 replace HD 405.1	Note: VDE 0482 parts 265-1 and -2-1 replace VDE 0472, part 804, test type B

The responsible project management and service departments must verify whether this standard satisfies the applicable building regulations and any other additional regulations.

### 1.9.3 Screened Lines for LAN, WAN, and DMZ Connections

The following prerequisites must be met in order to comply with CE requirements relating to the electromagnetic compatibility of the communication system and its LAN, WAN, and DMZ connections:

- The communication system may only be operated with screened connection cables. This means that a screened CAT.5 cable with a length of at least 3m must be used between the screened LAN, WAN, and DMZ connection sockets of the communication system and the connection to the building utilities or the connection to active external components. The cable screen on the cable end that connects to the building utilities or active external components must be grounded (building potential equalization connection).
- In the case of shorter connections with an active external component (LAN switch or similar), a screened CAT.5 cable must also be used. However, the active component must have a corresponding screened LAN connection with a grounded screened connector (building potential equalization connection).
- The screen properties of the cabling components must comply with the requirements of the European EN 50173-1 standard on generic cabling systems and with any requirements referenced therein. The European EN 50173-1 standard is derived from the global ISO/IEC 11801 standard.

- Building utilities that have integrated and screened symmetrical copper cabling in accordance with the requirements of class D of EN 50173-1 fulfill the condition above. Class D is also attained if components (cables, connection boxes, connection cables, etc.) of category 5 (CAT.5) are installed.
- In North America, UTP cabling is normally installed (US EIA/TIA 568A standard), and the following conditions apply to the LAN connections of communication systems there: The communication system may only be operated with screened connection cables. This means that a screened CAT.5 cable with a length of at least 3m must be used between the screened LAN, WAN, and DMZ connection sockets of the communication system and the connection to the building utilities or the connection to active external components. The cable screen on the cable end that connects to the building utilities or active external components must be grounded (building potential equalization connection).
- For the LAN connection to boards in LTUs, the notes regarding the shielding connection at the opening of the LTU frame must be observed accordingly.

## 1.9.4 Labeling



This device complies with the EU guideline 1999/5/EC as confirmed by the CE certificate.



This device has been manufactured in accordance with our certified environmental management system (ISO 14001). This process ensures that energy consumption and the use of primary raw materials are kept to a minimum, thus reducing waste production.

## 1.10 Data Protection and Data Security

This telephone system uses and processes personal data, such as call detail recording, telephone displays and customer data records.

In Germany, the processing and use of such data is subject to various regulations, including those of the Federal Data Protection Law (Bundesdatenschutzgesetz, BDSG). Observe all applicable laws in other countries.

The objective of privacy legislation is to prevent infringements of an individual's right to privacy based on the use or misuse of personal data.

By protecting data against misuse during all stages of processing, privacy legislation also protects the material interests of the individual and of third parties.

The customer is responsible for ensuring that the system is installed, operated and maintained in accordance with all applicable labor laws and regulations and all laws and regulations relating to data protection, privacy and safe labor environment.

## Introduction and Important Notes

### Documentation Feedback

Employees of Unify GmbH & Co. KG are bound to safeguard trade secrets and personal data under the terms of the company's work rules.

It is imperative to observe the following rules to ensure that the statutory provisions relating to service (on-site or remote) are strictly followed. This safeguards the interests of the customer and offers added personal protection.

#### **A conscientious and responsible approach helps protect data and ensure privacy:**

- Ensure that only authorized persons have access to customer data.
- Use the password features of the system with no exceptions. Never give passwords to an unauthorized person orally or in writing.
- Ensure that no unauthorized person can ever process (store, modify, transmit, disable or delete) or use customer data.
- Prevent unauthorized persons from gaining access to storage media, such as backup CDs or log printouts. This applies to service calls as well as to storage and transport.
- Ensure that storage media which are no longer required are completely destroyed. Ensure that no sensitive documents are left unprotected.

**Work closely with your customer contact; this promotes trust and reduces your workload.**

## 1.11 Documentation Feedback

If you have questions that are not answered by this document:

- Internal employees should contact their National Support Center.
- Customers should contact their retailer or the Unify Customer Support Center.

When you call, state the title, ID number, and issue of the document.

#### **Example:**

- **Title:** OpenScape 4000 V7 IP Solution, Service Documentation
- **ID number:** P31003H3170S101010020
- **Issue:** 2

## 2 System Overview

OpenScape 4000 offers the following deployment options.

- 1) The OpenScape 4000 server option 1 (EcoServer) supports converged-IP requirements involving analog, TDM, DECT or specialized vertical applications and is designed for centralized deployment. The compact hardware takes up less rack space, can be deployed in the data center, and is highly scalable and secure.
- 2) The OpenScape 4000 server option 2 (OpenScape EcoBranch) can serve in a simplex (i.e. non- redundant) deployment for medium size solutions together with the OpenScape Access modules.
- 3) OpenScape 4000 can also run on VMware® infrastructure and is qualified for the usage in data centers. This virtual solution offers high scalability in the same way as the EcoServer hardware. High security requirements will be ensured by VMware® features (as vMotion, High Availability).

These deployments provide a support up to 12,000 users per VMware® or OpenScape EcoServer deployment.

In the above deployments 1 and 3 OpenScape 4000 offers a Simplex, two Duplex (redundancy) and a Disaster Recovery option:

### 1) OpenScape 4000 Simplex

This non-redundant deployment is mostly chosen for cost effectiveness.

### 2) OpenScape 4000 Duplex

Within an OpenScape 4000 Duplex system one “Active” and one “Stand-by” unit for call control, CSTA connectivity and administration are available.

The failure of one unit is automatically detected and the switch-over to the redundant control happens without losing existing calls. OpenScape 4000 Duplex guarantees hot stand-by redundancy for call control and warm stand-by redundancy for application connectivity and management.

### 3) OpenScape 4000 Separated Duplex

The Separated Duplex solution offers hot stand-by call control resilience functionalities for geo separated communication servers.

### 4) OpenScape 4000 Disaster Recovery

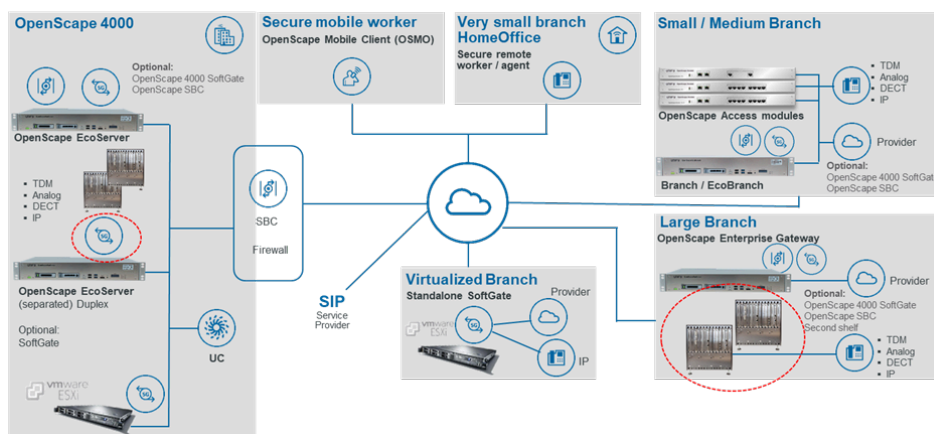
Customers can extend their OpenScape 4000 Duplex deployment by adding an additional OpenScape 4000 server placed in a separated location. In the case of a severe long-term outage (e.g. caused by flooding, fire or storms) of the active OpenScape 4000 server, this system can be activated by the administrator and takes over the functions of the main system.

## 2.1 OpenScape 4000 IP Distributed Architecture

An OpenScape 4000 communication solution consists of a central call control and locally or remotely attached access points. The IP distributed architecture (IPDA) allows building up stand-alone systems and cost-effective IP distributed branch concepts based on identical components via an IP infrastructure and enables functional and organizational benefits stemming from centralized applications and a central management.

## System Overview

### OpenScape 4000 Hardware



**Figure 1: OpenScape 4000 IP Distributed Architecture with centralized applications**

Up to 15 of the following access points (host shelves) can be attached locally:

- Access Point 3300 (still supported, but discontinued for new sales) or
- Access Point 3700

A mixed operation with AP3300 and AP3700 is not possible.

Additionally, up to 83 of the following IP Access Points are can be attached remotely:

- OpenScape Enterprise Gateway
- OpenScape EcoBranch (or predecessor OpenScape 4000 Branch)
- OpenScape 4000 SoftGate
- OpenScape Access 500a/i (still supported, but discontinued for new sales)
- Access Point 3300 IP (most configurations still supported but discontinued for new sales)
- Access Point 3700 IP (most configurations still supported but discontinued for new sales)

In a virtualized deployment of OpenScape 4000 only remotely attached access points (no locally connected AP3700) can be connected to the central call control.

## 2.2 OpenScape 4000 Hardware

This chapter describes the main HW components of an OpenScape 4000 solution. You'll find only the latest components, that are actively marketed and delivered. Nevertheless, a lot of older components / boards are still supported.

This is documented in an Excel file "OpenScape 4000 supported HW list" on the product homepage (also available via the partner Portal).

Please check also the Service Documentation: "OpenScape 4000, System Components" in the latest version.

The only OpenScape 4000 deployment variant for new systems is the integration in standard 19" equipment / racks.

You can still find information about the old deployment options and HW components, especially the 30" variant, in the OpenScape 4000 V10 documents.

## 2.2.1 OpenScape EcoServer

The OpenScape EcoServer is the main system control unit for OpenScape 4000.

This proprietary server unit contains the main processor module, the RTMx (Rear Transition Module) which connects to the AP3700 (LTU/host shelves), the MTS (Memory Time Switch) with 4.096 timeslots, the MCM (Management and Control Module) with alarming interfaces and fan control, timeslots for conferences, 12 DTMF sender/receiver and a clock generator function.

The OpenScape EcoServer is delivered with one SSD (Solid-State-Drive) and one AC or DC power supply. A second SSD as well as an additional power supply can be ordered separately. As an option it is possible to have a mixed configuration of AC and DC power supplies.

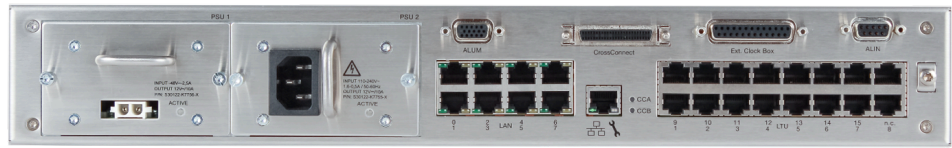
- 15 RJ45 connectors to connect the AP3x00 Access Points
- 8 x 1 Gbit LAN interfaces for external ports
- 1 x 1 Gbit LAN interface for remote management
- Redundant LAN and WAN sockets (Bonding)
- Optionally redundant power supply: combine power supplies as needed (AC/DC)

(the power supplies are identical to the previous OpenScape 4000 EcoServer)

- Optionally redundant SSD drive with fast start-up times and improved MTFB values
- When upgrading from OpenScape 4000 EcoServer to OpenScape EcoServer (optionally), the SSD drives can simply be taken over to the new server.
- 2 redundant high availability fans
- 1 USB slave port for maintenance access
- 4 USB ports (2x USB 3.0, 2x USB 2.0); the system is bootable from USB2 and USB3 devices
- Small OLED display, used for status messages
- 1x ALUM interface (VGA connector)
- 1x ALIN interface (Sub-D 9)
- 1x "Ext. Clock Box" interface (Sub-D 25)
- 1x CrossConnect interface for Duplex installations
- CCA/CCB-Status LEDs
- Display port interface for maintenance purposes
- Dimensions: 482,6mm x 66,7mm x 360m (1,5 Rack Units)
- CPU: AMD EPYC 3151, 4Cores/8Threads, 2.7GHz
- RAM: 16 GB (DDR4)

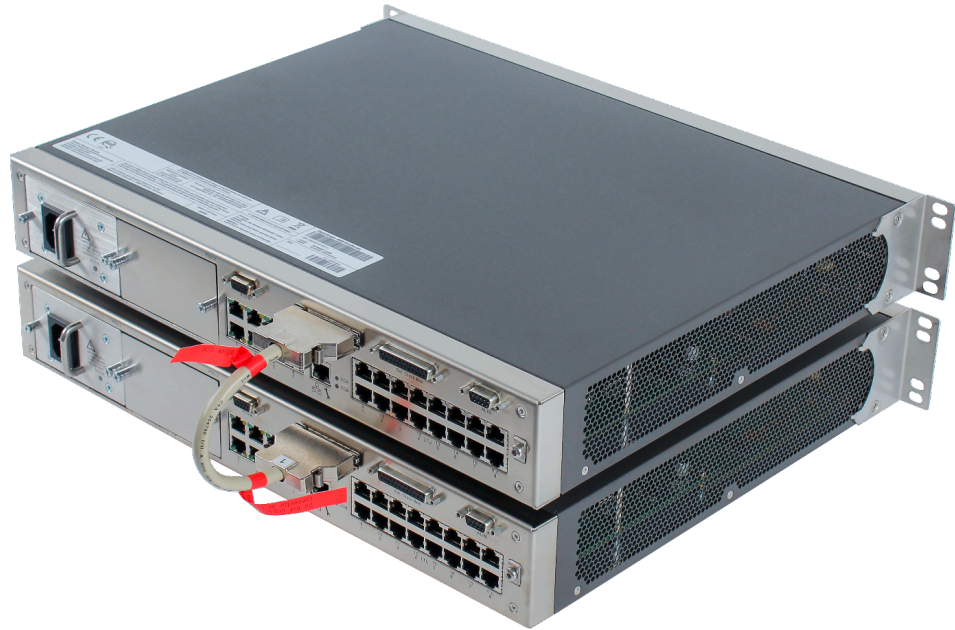


Figure 2: OpenScape 4000 Ecoserver front view



**Figure 3: OpenScape 4000 EcoServer rear view**

A Duplex system will be realized with two EcoServers, connected via a so called CrossConnect cable. The two servers must be of the same type, either OpenScape 4000 EcoServer or OpenScape EcoServer.



**Figure 4: OpenScape 4000 Duplex EcoServer**

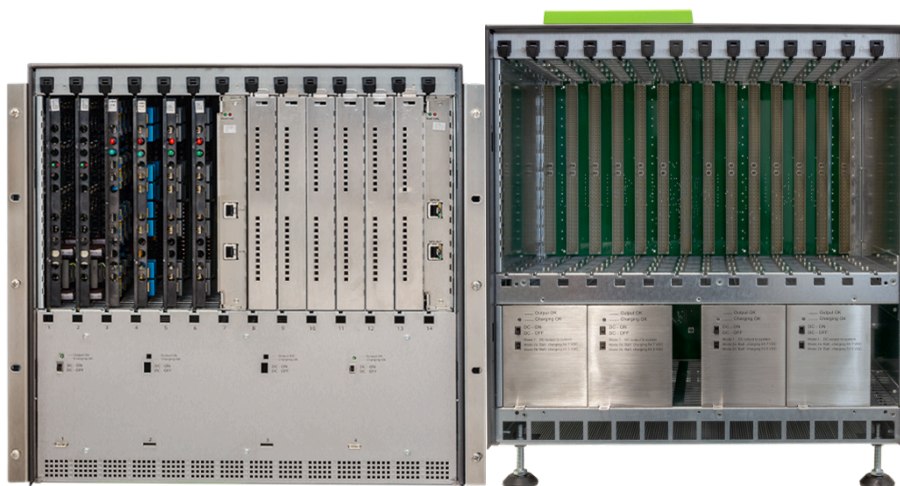
When ordering the OpenScape EcoServer as DC variant a DCDR fuse panel with four fuses will be delivered automatically. It can be mounted directly in the 19" server rack.

## 2.2.2 Access Point AP3700 (Host Shelf)

The AP3700 is a peripheral shelf that can be directly connected to the OpenScape EcoServer to host up to 13 peripheral boards (with either subscriber or trunk interfaces).

A 14th board (called LTUCR) in the middle of the shelf establishes the connection to the OpenScape EcoServer.

The AP3700 can be mounted in a standard 19" rack and uses 10 Rack Units. One Rack Unit must remain free at the top and bottom.



**Figure 5: Access Point AP3700**

Each AP3700 is powered by up to four power supply units (LUNA 2), which sit at the bottom of the shelf, depending on the configuration of the shelf and type of boards being used. N+1 redundancy can be considered via the ECS configurator.



**Figure 6: LUNA 2**

The OpenScope EcoServer and the required number of AP3700 shelves are installed in 19" racks:

- Up to three AP3700 modules and one OpenScope EcoServer can be integrated in the first rack.
- Up to four AP3700 modules can be installed in each subsequent rack.

Meaning, a fully equipped system with 15 AP3700 would require four 19" racks. The rack heights should also be planned in line with the relevant configuration and customer requirements.

Additional cooling measures:

Because the AP3700 shelves are designed for convection cooling, it may occur in configurations with more than two AP3700 shelves per 19" rack that additional cooling measures must be taken, depending on the type of rack used and the ambient temperature. This needs to be discussed with the

## System Overview

customer and the vendor of the 19" rack, which isn't part of the OpenScape 4000 deliverables.

The following pictures show the ventilation grille of the shelf:



### 2.2.3 Available interface cards

The following boards are the newest boards which are actually available for new sales.

Older components which are still supported can be found in an Excel file "OpenScape 4000 supported HW list" on the product homepage (also available via the partner Portal).

Please check also the Service Documentation: "OpenScape 4000, System Components" in the latest version.

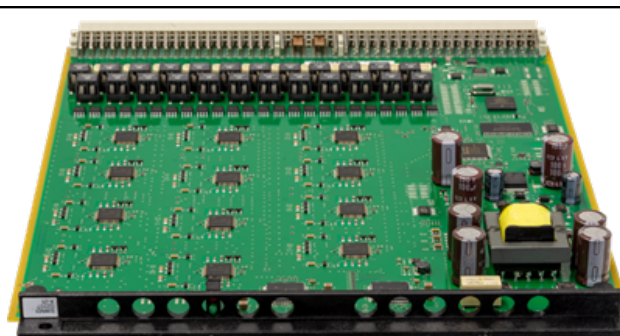
#### **SLMAV**

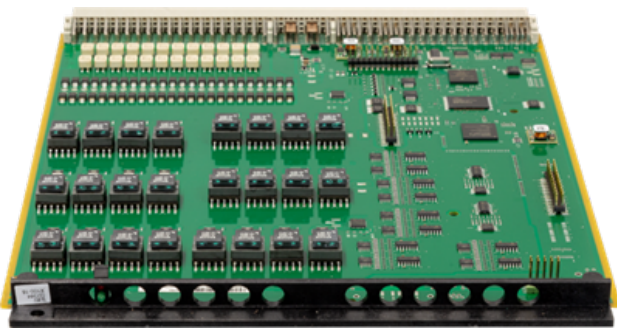
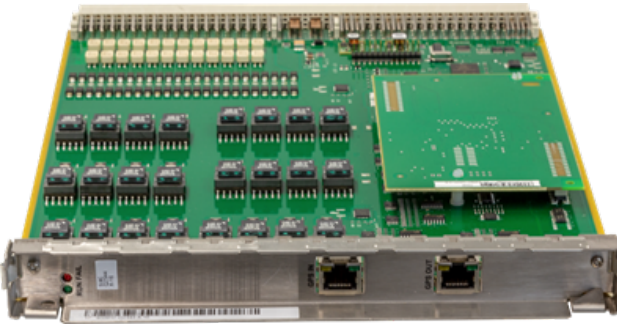
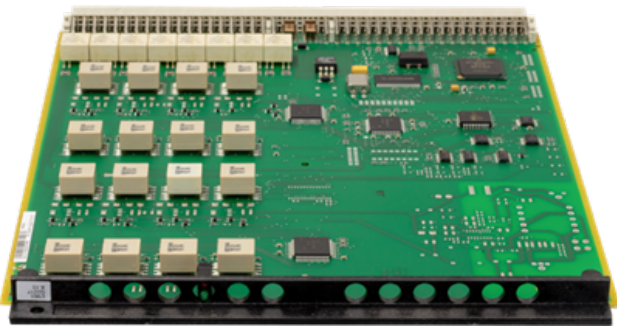
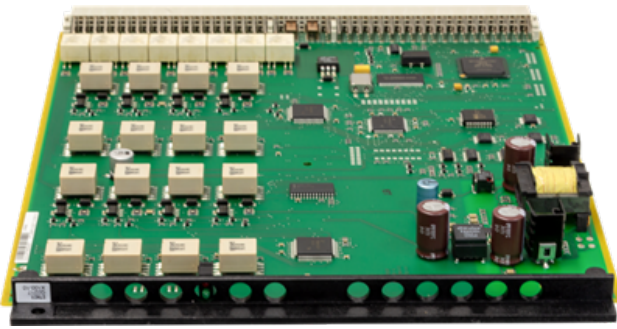
Subscriber Line Module Analog Vinetic  
with 24 interfaces to connect analog devices.

(S30810-Q2227-X)

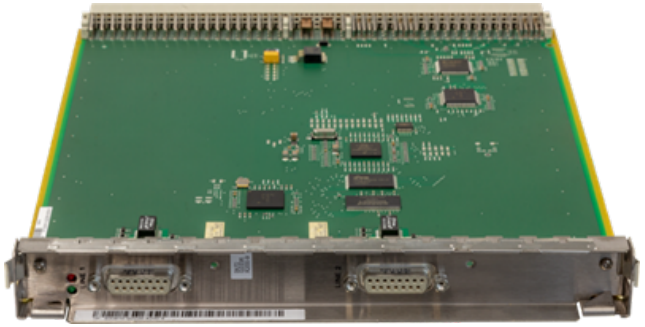
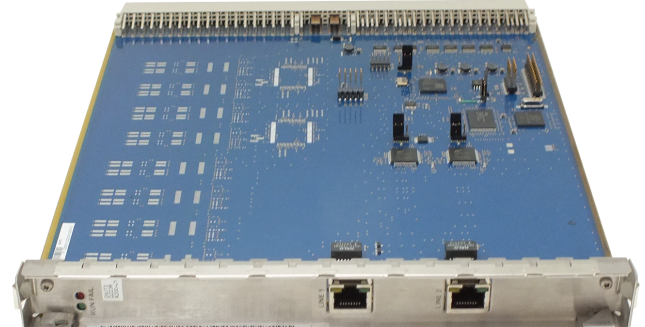
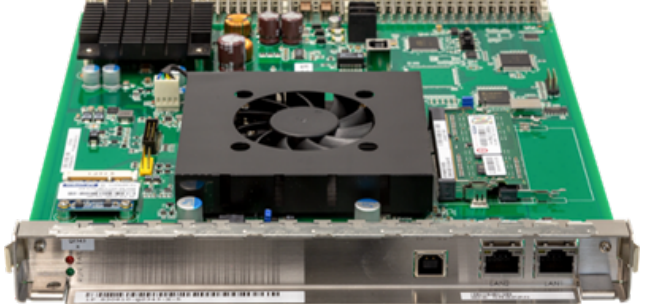
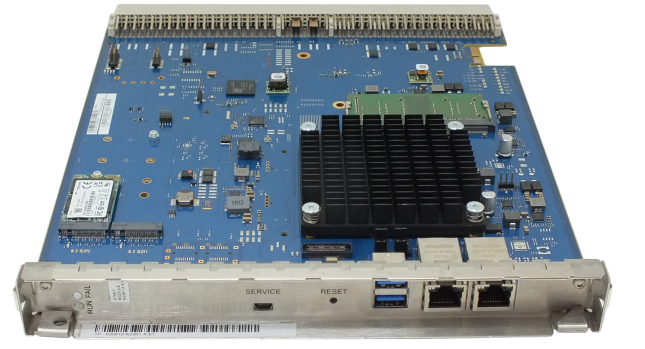
The SLMAV board supports calling name identification presentation (CLIP). This board generates its own ring voltages and does not require an external ring voltage generator.

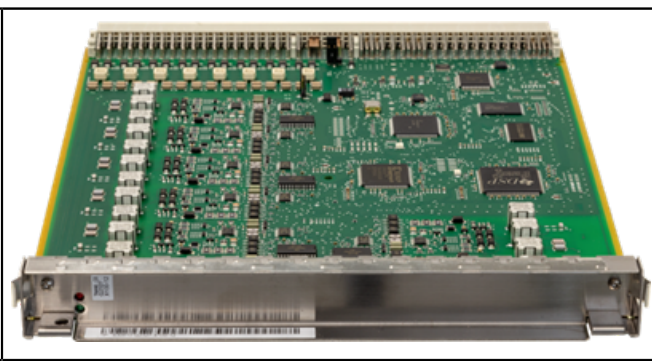
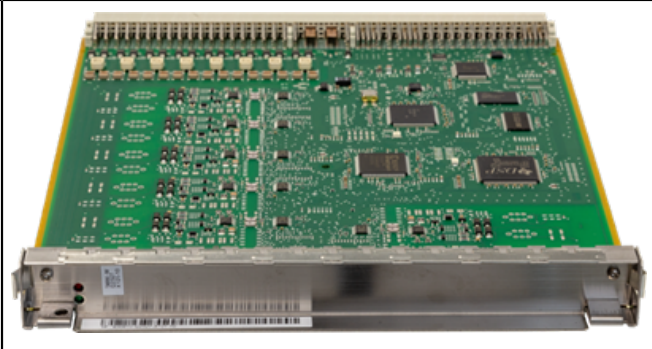

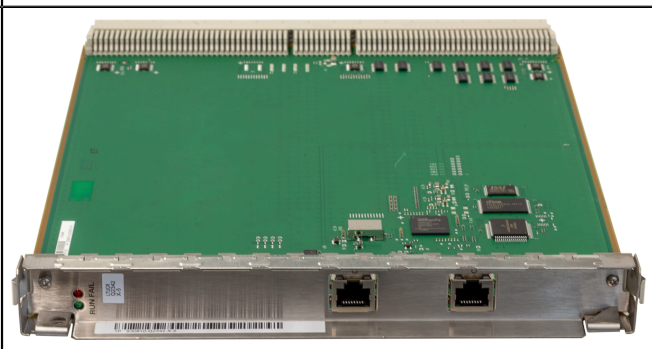
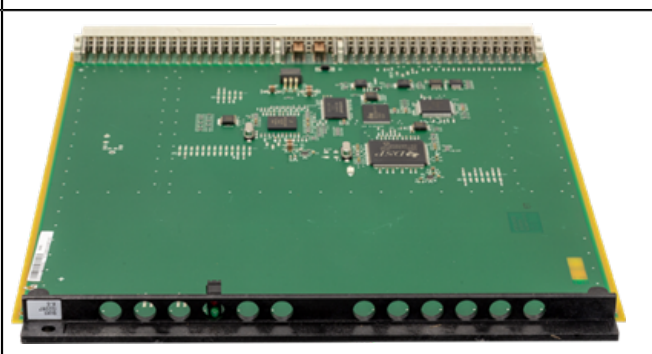
The SLMAV supports a line loop resistance of 1800 Ohms.



<p><b>SLMU</b></p> <p>Subscriber Line Module UP0/E (S30810-Q2344-X100)</p> <p>Two-wire 2B+D interface with 24 UP0/E ports to connect Unify's TDM phones.</p>	 <p>A green printed circuit board (PCB) for a Subscriber Line Module (SLMU). It features a dense array of 24 RJ45 ports on the front panel, arranged in two rows of 12. The board is populated with various integrated circuits, capacitors, and other electronic components. A black metal chassis is visible at the bottom edge.</p>
<p><b>SLMC</b></p> <p>Subscriber Line Module CMI (S30810-Q2344-X)</p> <p>Two-wire 2B+D interface with 24 UP0/E ports to connect DECT cordless base stations</p> <p>See also the Sales Information document for "OpenScape Cordless Enterprise V7"</p>	 <p>A green PCB for a Subscriber Line Module (SLMC). It has 24 RJ45 ports on the front panel. A distinctive feature is a large, rectangular silver-colored metal component mounted on the right side of the board, which likely houses a CMI (Cordless Mobile Interface) module. The board is densely packed with electronic components.</p>
<p><b>STMD3</b></p> <p>Station/Trunk Module Digital S0 without power supply (S30810-Q2217-X)</p> <p>Trunk/subscriber card with 8 S0 interfaces.</p> <p>Each S0 interface (4-wire) provides basic access with two B channels (each with 64 kbit/s) for voice/data transmission and one D channel (16 kbit/s).</p>	 <p>A green PCB for a Station/Trunk Module (STMD3). It features 8 RJ45 ports on the front panel, arranged in two rows of 4. The board is populated with various electronic components, including integrated circuits and capacitors. A black metal chassis is visible at the bottom.</p>
<p><b>STMD3</b></p> <p>Station/Trunk Module Digital S0 with power supply (S30810-Q2217-X100)</p> <p>Trunk/subscriber card with 8 S0 interfaces</p> <p>Each S0 interface (4-wire) provides basic access with two B channels (each with 64 kbit/s) for voice/data transmission and one D channel (16 kbit/s).</p>	 <p>A green PCB for a Station/Trunk Module (STMD3) with an integrated power supply. It has 8 RJ45 ports on the front panel. A prominent feature is a large power supply unit (PSU) mounted on the right side of the board, which includes several electrolytic capacitors and a transformer. The board is densely packed with electronic components.</p>

## System Overview

<p><b>DIUT2</b>          Digital Interface Unit Trunk 2          (S30810-Q2226-X200)</p> <p>Trunk board with E1 (30 channels) or T1 (24 channels) interfaces</p> <p>2 x E1          2 x E1 with CAS signaling          2 x T1 with MOS signaling          1 x T1 with BOS signaling</p>	
<p><b>DIUT3</b>          Digital Interface Unit Trunk 3          (S30810-Q2238-X200)</p> <p>Trunk board with E1 (30 channels) or T1 (24 channels) interfaces</p> <p>2 x E1          2 x E1 with CAS signaling          2 x T1 with MOS signaling          1 x T1 with BOS signaling</p>	
<p><b>STMIX</b>          Subscriber Trunking Module IP          (S30810-Q2343-X)</p> <p>Common IP Gateway HG 3500          see also chapter 1.2.5.4</p>	
<p><b>STMIY</b>          Subscriber Trunking Module IP          (S30810-Q2361-X)</p> <p>Common IP Gateway HG 3500          see also chapter 6.10 of the OpenScape 4000 System Components, Service Documentation</p>	

<p><b>TMANI-CE</b> Trunk Module Analog Interface (S30810-Q2327-X100)  Analog trunk board with 8 analog ports with GEE, with ground start</p>	
<p><b>TMANI-IM</b> Trunk Module Analog Interface (S30810-Q2327-X101)  Analog trunk board with 8 analog ports without GEE, without ground start</p>	
<p><b>TMANI-BRA</b> Trunk Module Analog Interface (S30810-Q2327-X182)  Analog trunk board with 8 analog ports only for Brazil, without GEE, without ground start</p>	
<p><b>LTUCR</b> Line Trunk Unit Control Replacement (S30810-Q2342-X)  Interface between central call control and the peripheral boards in the Access Point</p>	
<p><b>SIUX3</b> Signaling Interface Unit (S30810-Q2287-X)  Board to transmit and receive DTMF or MFC signals</p>	

## 2.2.4 OpenScape Enterprise Gateway

The OpenScape Enterprise Gateway is the solution for large branches connected to a central OpenScape 4000 system.

The HW part of the OpenScape Enterprise Gateway consists of the following components:

- OpenScape EcoServer
- AP3700 with 13 slots for peripheral boards
- LTUCR controller card
- Host shelf cable to connect AP3700 to the EcoServer

A second shelf can be added to the OpenScape Enterprise Gateway. Any mix of AP 3700 and AP3700 IP (older access point which is not available any longer for new sales) is possible. OpenScape Enterprise Gateways with an AP3300 shelf cannot be extended nor can an AP3300 be mixed with other access points.

---

**NOTICE:** Due to HW restrictions, the number of channels to the OpenScape Enterprise Gateway remains at 120 channels, i.e. also for the combination of 2 shelves.

---



Figure 7: OpenScape Enterprise Gateway with 2 shelves

## 2.2.5 OpenScape EcoBranch

The OpenScape EcoBranch is the solution for small to mid-size branches connected to a central OpenScape 4000 system. As such it succeeds the former OpenScape 4000 Branch and the older OpenScape Access 500a/i. All OpenScape Access modules can be connected.

The hardware is based on the OpenScape EcoServer:

- 8 X- Link connectors to connect the OpenScape Access modules
- 4 integrated a/b subscriber interfaces
- Redundant LAN and WAN sockets (Bonding)
- Optionally redundant power supply, combine power supplies as needed (AC/DC)
- Optionally redundant SSD drive with fast start-up times and improved MTFB values
- 2 redundant high availability fans
- Small OLED display, used for status messages
- Display port interface for maintenance purposes

The OpenScape EcoBranch can also be set-up as main OpenScape 4000 Call Control (instead of an EcoServer) in order to form an OpenScape 4000 Simplex system.



Figure 8: OpenScape EcoBranch - Front View



Figure 9: OpenScape EcoBranch - Rear View

## 2.2.6 OpenScape Access Modules

The OpenScape Access Modules provide means to connect legacy phones, trunks and cordless options to the OpenScape EcoBranch, via the so-called X-link interface.

To meet the design concept all OpenScape Access Modules fit into standard 19" racks, each with 1 Rack Unit height.

### OpenScape Access PRI

OpenScape Access PRI offers 2 ISDN primary rate interfaces (E1/T1).



**OpenScope Access BRI**

OpenScope Access BRI offers 8 ISDN basic rate interfaces (S0).



**OpenScope Access TA**

OpenScope Access TA offers 8 analog trunk interfaces. There are three flavors:

- TA-IM: without GEE, without ground start
- TA-CE: with GEE, without ground start
- TA-LAM: only for Brazil, without GEE, without ground start (No picture)



**OpenScope Access SLC-M**

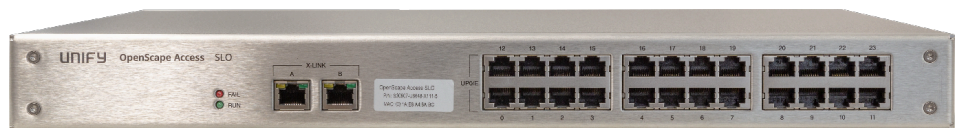
OpenScope Access SLC-M offers 24 digital lines to connect to DECT base stations. As it includes the support of Inter System Synchronization (ISS), it can be expanded beyond 24 base stations. Up to 6 OpenScope Access SLC-M modules can be combined to form one Cordless network.

For further information please refer to the OpenScope Cordless Enterprise V7 documentation.



**OpenScope Access SLO**

OpenScope Access SLO offers 24 Up0 digital subscriber lines.



**OpenScope Access SLA**

OpenScope Access SLA offers 24 analog subscriber lines.



**OpenScope Access Rear View**



**OpenScope Access Side View with ventilation grille**



## 2.2.7 Main Distribution Frame / Cabling

For connecting the OpenScape 4000 interfaces to the building cable network three different options are available:

- 1) Main Distribution Frame** For larger installation and sites where an MDF is already existing open-end cables from the AP3700 / subscriber/trunk boards can be provided with a maximum length of 95m. The connector which fits to the backplane of the AP shelf is called SIVAPAC.

If a new MDF needs to be installed 3rd party products need to be considered.

A Unify specific MDF isn't available any longer for new sales.



- 2) Internal Patch Panel**

For smaller installations plug-in patch panels for each subscriber/trunk board can be mounted on the rear side of each AP3700. The variant to be used

depends on the type of card to be connected. Each plug-in patch panel directly connects to the backplane connector of the subscriber/trunk board.



Figure 10: Patch-Panel with 24 RJ45 sockets (NPPAB, S30807-Q6622-X)



Figure 11: Patch-Panel with 8 RJ45 sockets (NPPSC, S30807-Q6624-X)



Figure 12: Rear View



Figure 13: Patch-Panel with CHAMP-socket (NPPSC, S30807-Q6626-X)



### 3) External Patch Panel:

An external Patch Panel (L30220-Y600-M32) can be mounted into any 19" rack.



24-Pair cables (2m, 5m or 15m) with connectors on both sides can be ordered to connect the backplane of the AP3700 to the external Patch Panel.

- 2m (S30267-Z333-A20)
- 5m (S30267-Z333-A50)
- 15m (S30267-Z333-A150)
- CABLUE Overvoltage Protector (S30807-K6192-X)

### 3 Preparing for Installation

This chapter contains important information and describes the steps involved in installing cabinets with main distribution frames.

#### 3.1 Work steps

**Table 1: Installation Matrix**

Installation Steps	Refer to:	OK?
STEP 1. Preparation		
Installation materials	<a href="#">Section 3.2, Installation Materials</a>	
Verify the site.	<a href="#">Section 3.3, Conducting the Site Verification</a>	
Receive the system.	<a href="#">Section 3.4, Receiving the System</a>	
Inspect for shipping damages.	<a href="#">Section 3.5, Inspecting for Shipping Damage</a>	
Remove the system from its packaging.	<a href="#">Section 3.6, Removing the System from its Packaging</a>	
Remove the system from the pallet.	<a href="#">Section 3.7, Unloading a System with a Roller Base from the Pallet</a>	
Position the cabinets.	<a href="#">Section 3.8, Positioning the Cabinets</a>	
Level the cabinets.	<a href="#">Section 3.9, Leveling the Cabinets</a>	
Remove the front covers.	<a href="#">Section 3.10, Removing the Front Covers</a>	
Remove the back covers.	<a href="#">Section 3.10.3, AP 3300 Back Covers</a>	
Check and read the labels in the cabinets.	<a href="#">Section 3.11, Important Labels on the System</a>	
Inventory the system hardware.	<a href="#">Section 3.12, Inventorying the System Hardware</a>	
Inventory the system software.	<a href="#">Section 3.13, Inventorying the System Software</a>	
Inventory the installation kit.	<a href="#">Section 3.14, Inventorying the Installation Kit</a>	
Perform pre-installation trunk procedures.	<a href="#">Section 3.15, Pre-Installation Trunk Procedures</a>	

Installation Steps	Refer to:	OK?
Install seismic anchors, if applicable.	<a href="#">Section 3.16, Installing Seismic Anchors</a>	
Install the cable channels.	<a href="#">Section 3.18, Installing the Cable Channels</a>	
STEP 2. Ground the OpenScape 4000.		
Ground the MDF, I.M.	<a href="#">Section 6.1, Grounding the Main Distribution Frame (MDF)</a>	
Connect and ground the cabinets.	<a href="#">Section 6.2, Connecting and Grounding the Boxes in the 30" Cabinet</a>	
Ground the system.	<a href="#">Section 6.3, Grounding the System (30" cabinet)</a>	
STEP 3. Connect the power supply.		
Connect to the mains.	<a href="#">Section 7.1, Connecting to the Mains</a>	
Install a three-phase connection.	<a href="#">Section 7.2, Installing a Three-Phase Network</a>	
Install a single-phase connection.	<a href="#">Section 7.3, Installing a Single-Phase Network</a>	
Install a three-phase or single-phase connection with mid-point grounding.	<a href="#">Section 7.5, Installing a Three-Phase or Single-Phase Connection with Mid-Point Grounding, I.M.</a>	
Connecting the Battery to the Power Box, I.M.	<a href="#">Section 7.13.1, Connecting the Battery to the Power Box, I.M.</a>	
Connect the MDF (I.M.).	<a href="#">Section 7.22.1, Connecting the MDF for a Redundant System, I.M.</a>	
Connect the power box to the system.	<a href="#">Section 7.22, Connecting the Power Box to the System</a>	
STEP 4. Install the signal cables.	<a href="#">Section 8.1, Installing Signal Cables</a>	
STEP 5. Install the service alarm cable and trunk bypass.	<a href="#">Section 8.2, Installing the Service Alarm Cable and Trunk Bypass</a>	
STEP 6. Install the external cables.	<a href="#">Section , External Cabling Assemblies</a>	
STEP 7. Install the peripheral equipment, if applicable.	<a href="#">Section , Installing Peripheral Equipment</a>	

## Preparing for Installation

Installation Steps	Refer to:	OK?
STEP 8. Install the IPDA, if applicable.	<a href="#">Section , Installing the IPDA</a>	
STEP 9. Start the system.		
Perform pre-power-on checks.	<a href="#">Section 12.2, Pre-Power On Checks</a>	
Apply power to the OpenScape 4000.	<a href="#">Sections 12.3 to 12.9</a>	
Enable the clock batteries.	<a href="#">Section 12.10, Activating the RTC Battery on the DSCXL2 Board</a>	
Set the date and time.	<a href="#">Section 12.11, Setting the Date and Time</a>	
Install the database.	<a href="#">Section 12.12, Installation Processes</a>	
Start the OpenScape 4000.	<a href="#">Section 12.13, Starting the System</a>	
Connect to the maintenance terminal.		
Replace the covers.	<a href="#">Section 12.14, Replacing the Covers</a>	
STEP 10. Verify the System.		
Check the boards.	<a href="#">Section 13.2, Checking the Boards</a>	
Check the cables.	<a href="#">Section 13.3, Checking the Cables</a>	
Check and test the features.	<a href="#">Section 13.4, Checking and Testing the Features</a>	
Test the restart and failure transfer function.	<a href="#">Section 13.5, Testing the Restart and Failure Transfer Function</a>	
Backup the customer data.	<a href="#">Section 13.6, Backing up the Customer Data</a>	
Set and activate the HTS function.	<a href="#">Section 13.7, Setting and Activating the SIRA Function</a>	
Verify the ring generator.	<a href="#">Section 13.8, Checking the Ring Generator</a>	
Verify the station-to-MDF connections.	<a href="#">Section 13.9, Verifying the Station-to-MDF Connections</a>	
Verify transmission facilities.	<a href="#">Section 13.10, Verifying Transmission Facilities</a>	

Installation Steps	Refer to:	OK?
Verifying the hard disk	<a href="#">Section 13.11, Verifying the Hard Disk</a>	
Verify the operation of system features and servers.	<a href="#">Section 13.12, Verifying the Operation of System Features and Servers</a>	
Verify the system bypass	<a href="#">Section 13.13, Verifying the System Bypass</a>	
Installation Steps	Refer to:	OK?

### 3.2 Installation Materials

No special tools are required to assemble the OpenScope 4000 components. It is assumed that you have common electrician's tools and, if necessary, measuring and testing instruments. If further work is to be carried out in the building or at other components/parts, like 19" racks, the tool set must of course be adapted accordingly to include a drill, spirit level, etc.

### 3.3 Conducting the Site Verification

Arrange for a qualified electrical contractor to conduct a walk-through with you and check the site for customer compliance to site engineering conditions, including power and protective grounding connection point (equipotential bonding bar), cabinet and peripheral space allocations and safety requirements. In the U.S., customer site requirements are specified in the following documents:

- Site map
- *Customer Site Planning Guide*
- *Power and Grounding Guide and Specifications.*

### 3.4 Unpacking and checking the delivery



**CAUTION:**

Risk of injury when unpacking the system.

Never try to lift heavy objects without assistance.



**WARNING:**

Electric shock caused by damaged material.

Replace the power cable immediately if it shows any signs of damage.

Replace any damaged safety equipment (covers, labels and ground wires) immediately.

### 3.5 Important Labels on the System

Upon removing the covers, pay attention to the labels that are on the system

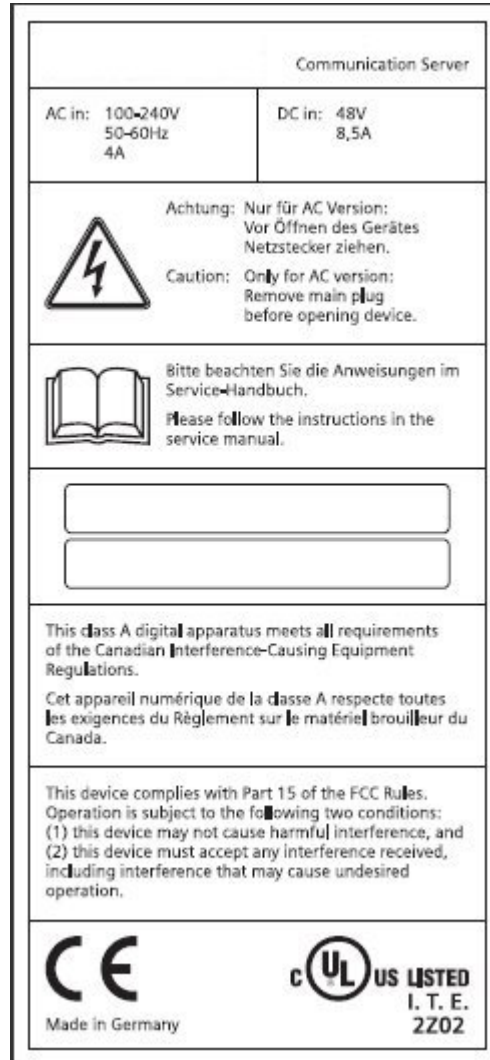


Figure 14: Type and rating plate

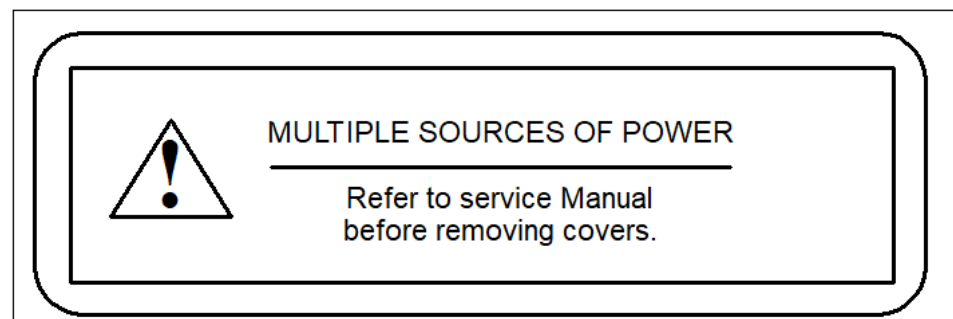


Figure 15: Cover label

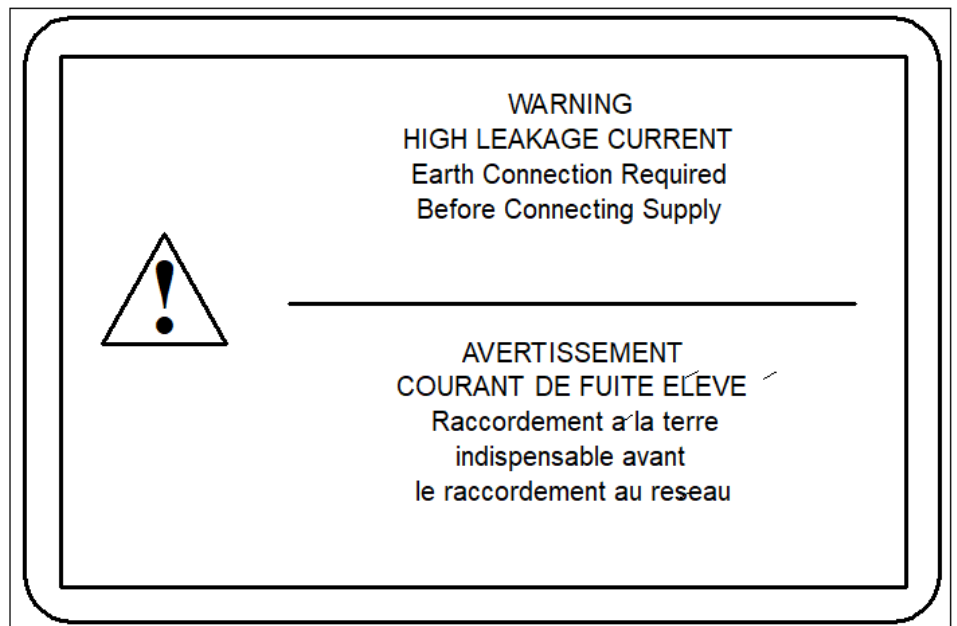
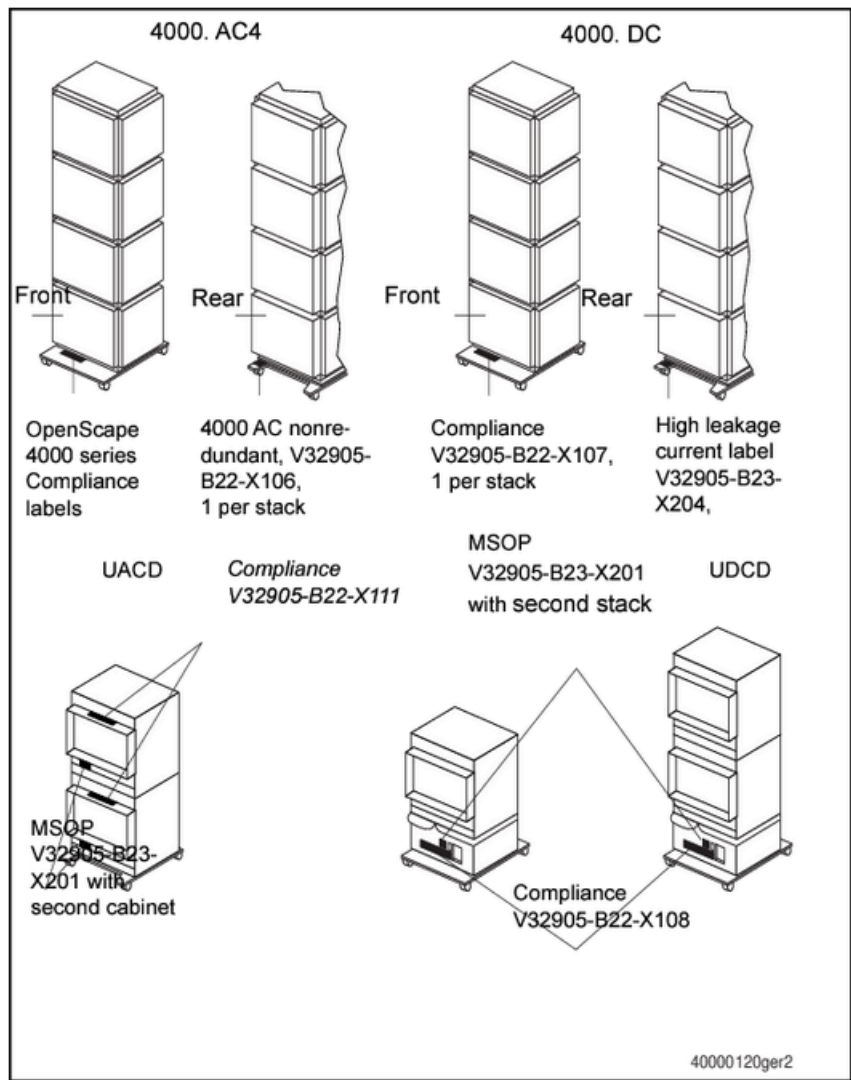


Figure 16: High leakage current label



**Figure 17: Locations of the labels on the system**

### 3.6 Installing Seismic Anchors

Depending on the regulations in your state or country, you may be required to install seismic anchors. Consult your facility's technical personnel if your installation requires seismic anchors; refer to the procedure described below.

The following information about installation of seismic anchors is based on the 2001 California Building Code.

To install the seismic anchors:

- 1) Ensure that the earthquake kits are supported on a floor located at or below grade level of the building.

- 2) Ensure that a qualified engineer reviews the anchorage and adequacy of the floor for the following conditions:
  - The concrete is normal weight stone aggregate concrete with a compressive strength of a least 2,000 psi.
  - If on-site concrete specifications are not available, strength is determined by testing cores, if required by OSHPD.
  - The floor slab is at least 4 inches thick and capable of supporting loads imposed by the equipment.
  - Drilled-in anchors must be used on prestressed concrete floors (pre- or post-tensioned) unless tension wires are positively located (refer to step 5).
- 3) Install the anchors in accordance with applicable provisions of the International Conference of Building Officials (ICBO) Evaluation Report and manufacturer's recommendations (refer to Fischerwerke Artur Fischer GMBH & Co. KG, D-72178 Tumlingen, Waldachtal, Germany).
- 4) Perform a load test of 50% of the anchors in accordance with the California Department of General Services, division of State Architect, Interpretation of Regulations Document 19-1, September 1, 1999 (reference, Expansion Bolts or Epoxy Type Anchors in Concrete). There are two methods for load testing the anchors:
  - Hydraulic Ram Method-the test load for the 12 mm anchors in tension is 3200 lbs.
  - Torque Wrench Method-the installation torque is 35 ft-lbs according to manufacturer's specifications. The test torque must be reached within one-half turn of the nut. Torque testing can occur on an individual basis if test procedures have been submitted to and approved by OSHPD.
- 5) When installing drilled-in anchors into existing pre-stressed concrete (pre- or post-tensioned), locate the prestressed tendons by using non-destructive methods before installation.

---

**NOTICE:** Use extreme care and caution when you install drilled-in anchors in existing non-prestressed reinforced concrete to avoid cutting or damaging the existing reinforcing bars and tension wires during installation.

---

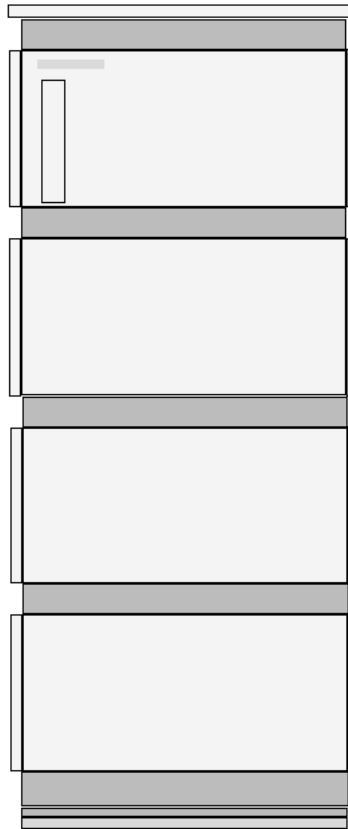
- 6) Maintain a minimum clearance of one inch between the reinforcement and the drilled-in anchor.
- 7) The M8 high-strength bolts that connect the bracket to the cabinet frame are Grade 5. Tighten the bolts to 35-40 ft-lbs. to ensure that they do not slip in the slotted holes.

### 3.7 Stacking OpenScape 4000 Cabinets

The factory ships the OpenScape 4000 cabinets already stacked according to configuration of the system that has been ordered (see [Figure 15](#) for an example).

To add cabinets to the system, refer to [Section „Adding Cabinets to the System“](#).

**Preparing for Installation**  
Installing the Cable Channels

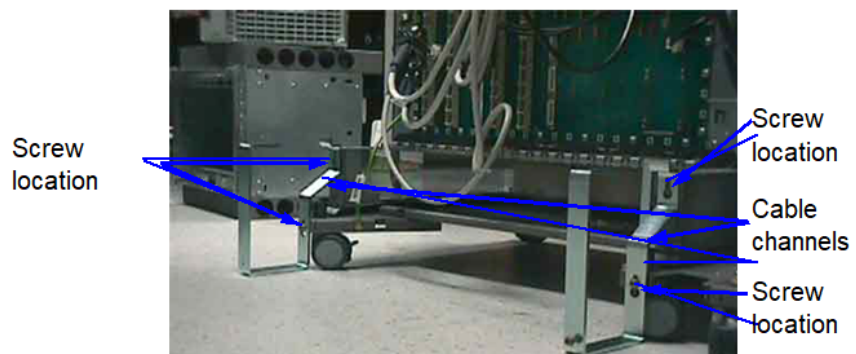


**Figure 18: OpenScape 4000 stacked cabinets (front view)**

### 3.8 Installing the Cable Channels

To install the cable channels:

- 1) At the back of the base cabinet, place the cable channel against the cabinet as shown in [Figure 16](#).
- 2) Secure the cable channels with screws.



**Figure 19: Cable channels**

## 4 Installation

This chapter provides instructions about installing the OpenScape 4000.

### 4.1 Installing the OpenScape EcoServer/EcoBranch

- 1) 19" Rack
- 2) 30" Rack. To install the EcoServer in the 30" shelf, you have to first pre-assemble the corresponding adapter frame.

#### 4.1.1 Pre-assembling the Adapter Frame (Simplex)

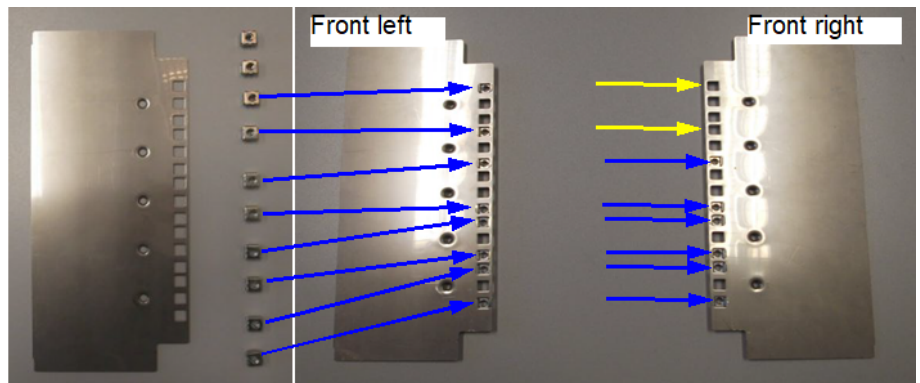
This installation step describes the pre-assembly of the front retaining plate if only one EcoServer is installed (not duplex).

- 1) First take the front retaining plate with the associated retaining nuts and position these as shown in the next diagram in the designated fixing holes.

---

**NOTICE:** If two EcoServers are being installed (in duplex mode), you have to install a further two retaining nuts to the top right on the front retaining plate (yellow marking).

---



**Figure 20: Pre-assembly of front retaining plate**

- 2) Take the two adapter frames and secure the rear retaining plates including retaining nuts using 5 screws each (yellow marking) to the respective adapter frame.

---

**NOTICE:** If two EcoServers are being installed (in duplex mode), you have to omit the two retaining nuts to the top right (see blue marking).

---

## Installation

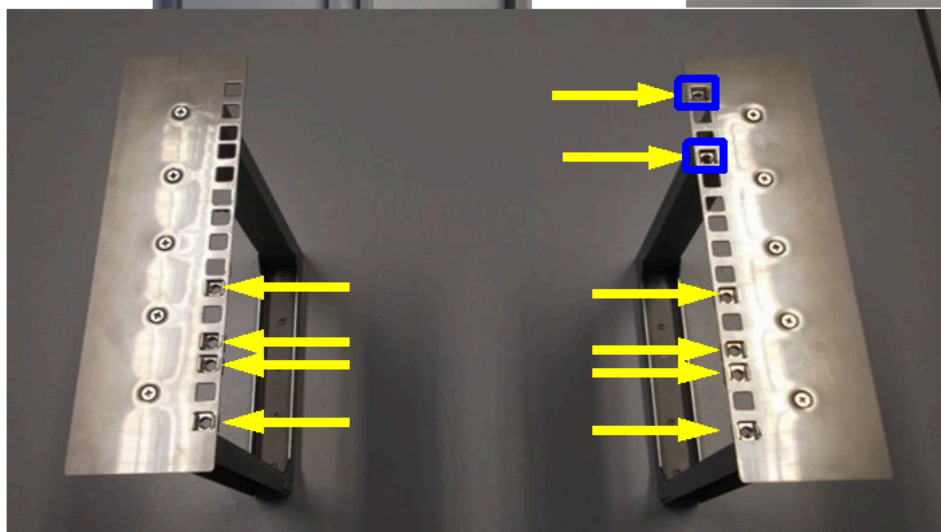
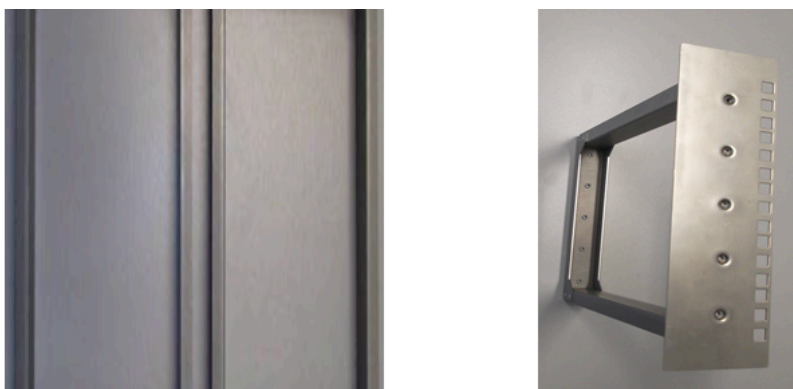
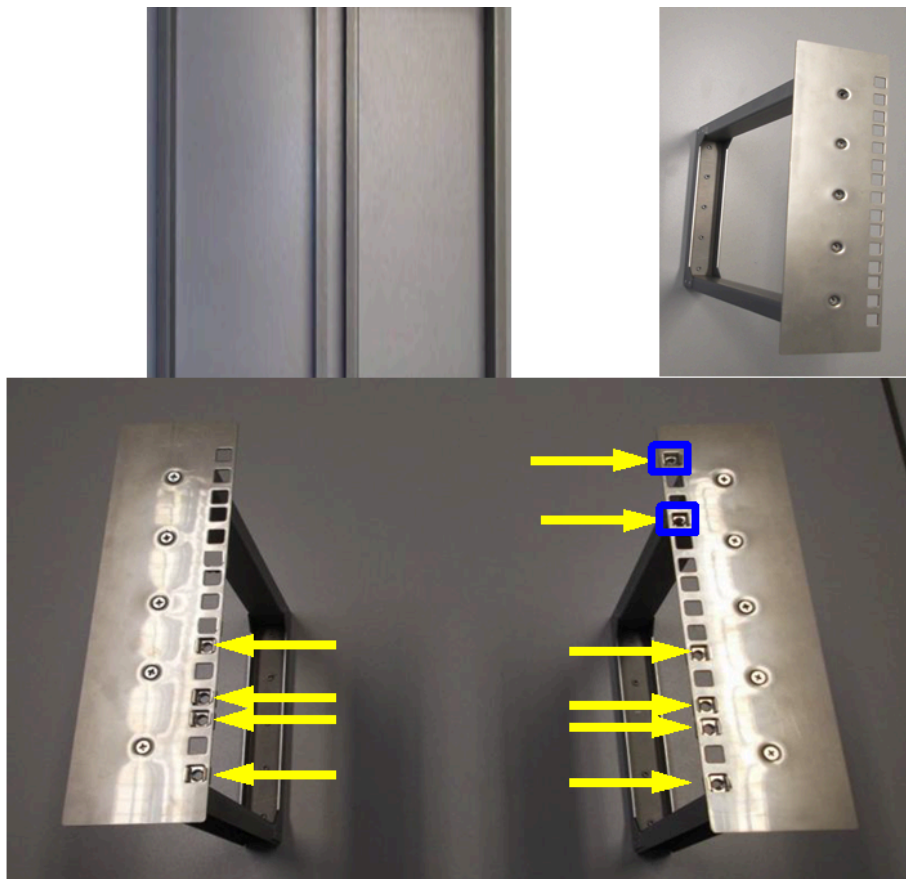


Figure 21: Pre-assembling the adapter frame with rear retaining plates

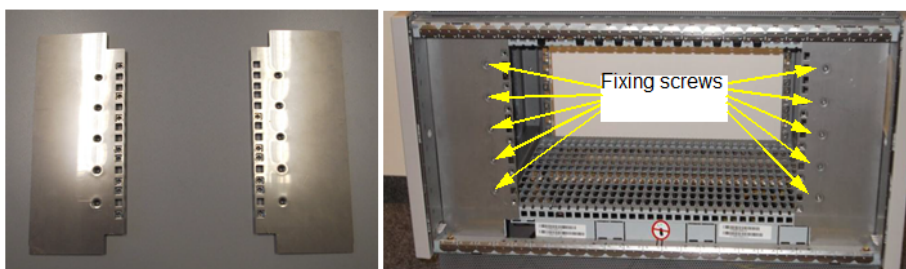
### 4.1.2 Installing the Adapter Frame

- 1) Now push the two adapter frames from the rear into the server shelf so that the plates are fitted to the left and right of the frame as shown in the next diagram (yellow marking).



**Figure 22: Pushing the adapter frame into the shelf from the rear**

- 2) Now tightly screw the pre-assembled front retaining plates for the EcoServer to the front of the adapter frame using 5 screws each.



**Figure 23: Securing the front retaining plates to the adapter frame**

### 4.1.3 Installing Lower Air Baffles

**NOTICE:** It is essential for structural engineering reasons that a minimum spacing of at least two height units (HU) is maintained below for installing the EcoServer in the processor shelf.

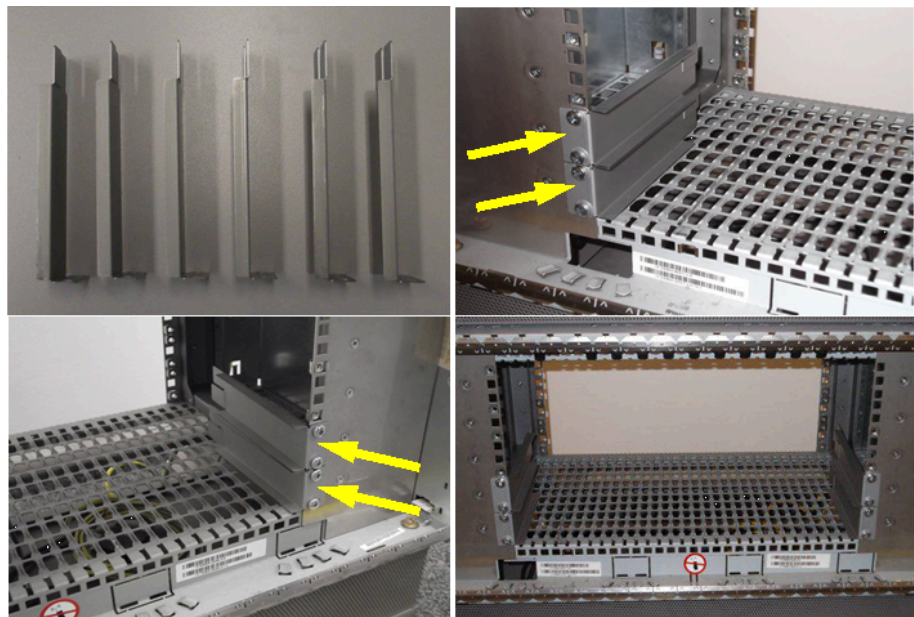
Because the EcoServer has a greater installation depth than the CSPCI/CCDAX server, the LTU cables coming from above run very close to the rear of the EcoServer. If the minimum spacing of 2 height units is not observed when installing the EcoServer in the processor shelf, issues could arise when connecting the cables to the rear of the EcoServer (depending on the system configuration), because the shielding of the cabling coming from above is grounded firmly with cable ties at the bottom of the cabinet shelf and the cables cannot then be pushed aside as required.

---

**NOTICE:** The rear air baffles have to be installed as shown in [Figure 19](#) for using the DCDR. Install the DCDR at the position where the front four air baffles are positioned. See also [Figure 18](#).

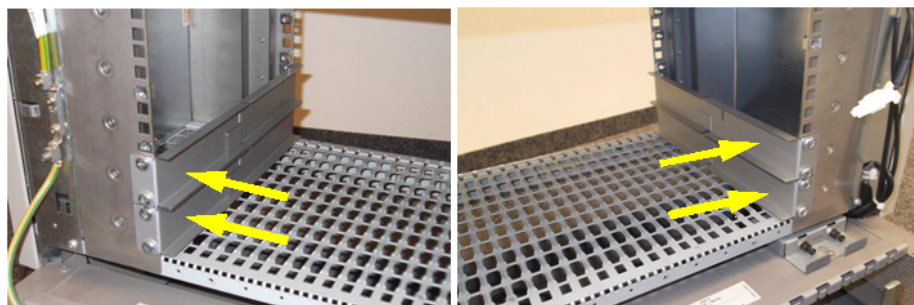
---

- 1) First secure two air baffles at the front (can also be used as a support for the EcoServer) to the left and right at the bottom of the shelf, as shown in the next diagram.



**Figure 24: Installing air baffles (front)**

- 2) Now likewise secure two air baffles each to the bottom left and right at the rear of the processor shelf.



**Figure 25: Installing air baffles (rear)**

### 4.1.4 Installing the EcoServer

- 1) Push the EcoServer from the front into the processor shelf and screw it tightly to the front plate left and right using two screws each.



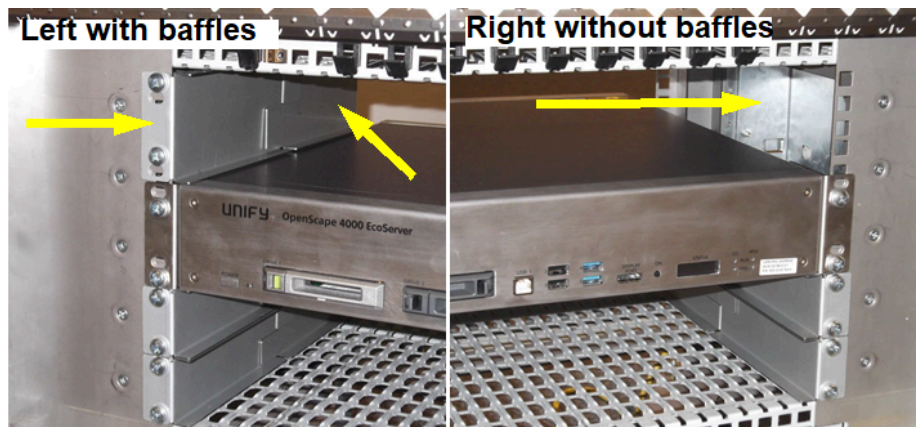
**Figure 26: Installing the EcoServer**

- 2) Now secure the upper air baffles above the EcoServer (unless in duplex mode) on the left side only, as viewed from the front. Because the EcoServer fan is positioned on the right, no air baffles may be installed on the right so that the warm air can escape freely upwards.

---

**NOTICE:** If two EcoServers are installed (in duplex mode), no air baffles may be installed at the top.

---



**Figure 27: Air baffles above the EcoServer in simplex mode**

- 3) Now secure the front and rear cover of the shelf again.

### 4.1.5 Installing the DCDR

The DCDR (incl. its DC cable) is used to connect the EcoServer to the DC supply, similar to the wiring of the previous cPCI shelf. An additional DCDR can be used if necessary (e.g. EcoServer duplex with redundant DC PSU -> 4x DC inputs).

## Installation

### Installing AP 3700 Cabinets in 19-Inch Cabinets



Figure 28: DC connection of EcoServer with DCDR (DC kit for 30" cabinet)

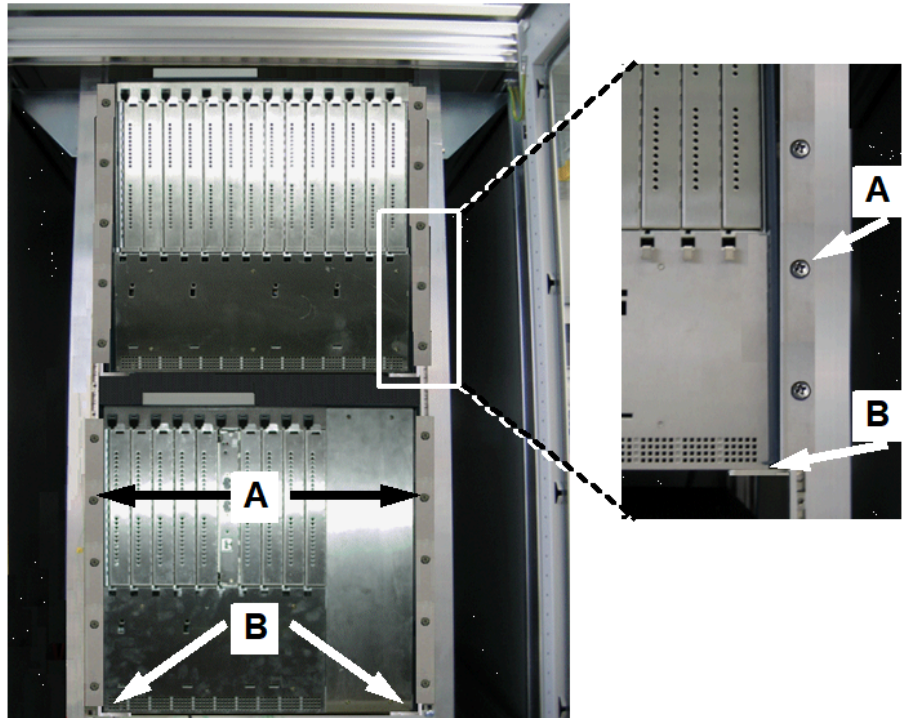
## 4.2 Installing AP 3700 Cabinets in 19-Inch Cabinets

When installing a multiple-cabinet system in a 19-inch cabinet, each system cabinet must be installed one at a time.

The following components are needed for installing a system cabinet:

- Two cabinet-specific bearing elbows with an ultimate load > 40 kg supplied by the 19-inch cabinet vendor.

- Two support brackets (order number C39165-A7075-D1), included in the system cabinet scope of delivery.



**Figure 29: Bearing elbow and support bracket for AP 3700 in the 19-inch cabinet**

Sequence of installation:

- 1) Remove all four feet on the system cabinet. Do this by loosening the lock nuts (1) on the feet (see [Section 3.9, Leveling the Cabinets](#)) using an open-ended socket wrench (wrench diameter = 13 mm). Turn the feet completely outwards.
- 2) Secure both support brackets (A, in [Figure 9](#)) to the sides of the system box with four of the screws supplied.
- 3) Secure a right and left bearing elbow (B, in [Figure 9](#)) in the 19-inch cabinet with the screws provided.
- 4) Lift the system cabinet into the 19-inch cabinet and sit the cabinet on the two bearing elbows (B, in [Figure 9](#)). Push the cabinet into the 19-inch cabinet until the front edge of the cabinet is flush with the front of the 19-inch frame.



**CAUTION: Risk of injury when lifting heavy objects/loads**  
**Always seek assistance before lifting a system cabinet into the 19-inch cabinet - never do it on your own.**

- 5) Secure the system cabinet to the frame of the 19-inch cabinet by means of the two support brackets (A, in [Figure 9](#)) and the screws provided. Make sure the minimum play specified for the system cabinets is provided (see [Section 5.8.3, AP 3700 Configuration Rules and Examples with 19" Cabinets/Open Racks](#)).
- 6) Repeat steps 1 to 5 to install additional expansion cabinets.

### 4.3 Removing / Installing Boards

When pulling or plugging an assembly, the processes for the protection of electrostatic sensitive components (ESD) must be followed. If the protective measures are not observed, permanent or sporadic board errors are possible.

---

**NOTICE:** Follow the electrostatic discharge prevention procedures. - Always put on the ESD wrist strap on your bare wrist before you touch any of the boards or assemblies. Only transport the boards in ESD protective packaging. Always place and work with the boards on a grounded conductive pad.

---

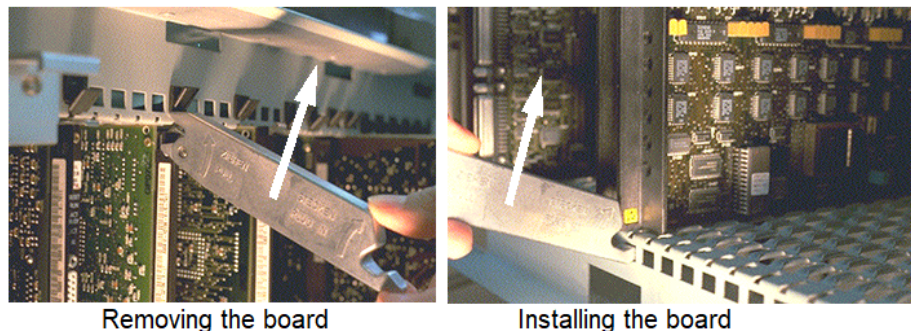


**WARNING: Risk of electric shock while working on the power system To avoid electrical shock, never wear the ESD wrist strap while working on the power system or at the back of the cabinet. Danger of electric shock!**

---

To remove or install boards:

- 1) Only use a board removal and replacement tool (see [Figure 1](#)).
- 2) Refer to the markings on the board removal and replacement tool for instructions on how to use it.



**Figure 30: Removing and installing the board**

#### 4.3.1 SIVAPAC-to-SIPAC Adapter

This adapter is no longer marketed or delivered and not needed to set up a new OpenScape 4000 system with the boards listed above (in chapter [Removing / Installing Boards](#) on page 50).

However, this adapter could still appear when taking over very old boards from older systems.

The AP3700 shelf is equipped with 24-port SIPAC connectors on the backplane.

This means some very old card types are not fully compatible with the AP3700 shelf, since they are fitted with 16-port SIVAPAC connectors.

**In addition, these cards always require a CABLUE overvoltage protection adapter (plugged between the shelf connector and the cable connector).** The SIVAPAC-SIPAC adapter allows the use of such old card types in AP3700 shelves.

Due to the installed adapter, the 16-port cards protrude a little further from the shelf.

To lock the 16-port boards into position, special latches are provided above (black) and below (gray) the shelf. When the adapters are installed, only the gray latches lock into place.

---

**IMPORTANT:** The Adapter 1 has three pieces: one power-up module and two adapter modules (see [Figure 32: Installing SIVAPAC-to-SIPAC adapter 1 \(2 of 2\)](#) on page 52). Once installed, never remove the board adapters. You must install the 16-port adapters manually, as they cannot be installed using the board removal and replacement tool. You cannot use this tool to seat boards with gray latches into place. To remove the boards, follow the instructions in [Section 4.1, Removing / Installing Boards](#).

---

To install the board adapter (see [Figure](#) and [Figure](#)):

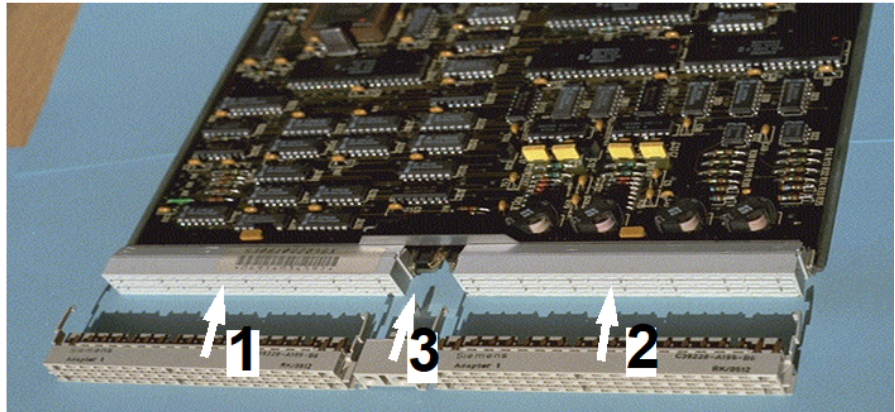
- 1) Release the gray latch in front of the board.
- 2) Remove the board from the shelf.
- 3) Face the backplane connector of the board toward yourself.
- 4) On the adapter module (labeled 1 and 2), slightly pull the catch hooks apart.
- 5) Position the adapter module over the backplane connector of the board.
- 6) Ensure that the outer edge of each adapter module corresponds with each outer edge of the board.
- 7) Ensure that each adapter module's outermost row of pins is aligned with the outermost row of the board connector, then insert the module into the connector.
- 8) Snap on the catch hooks.
- 9) Install the other module onto the board connect.

---

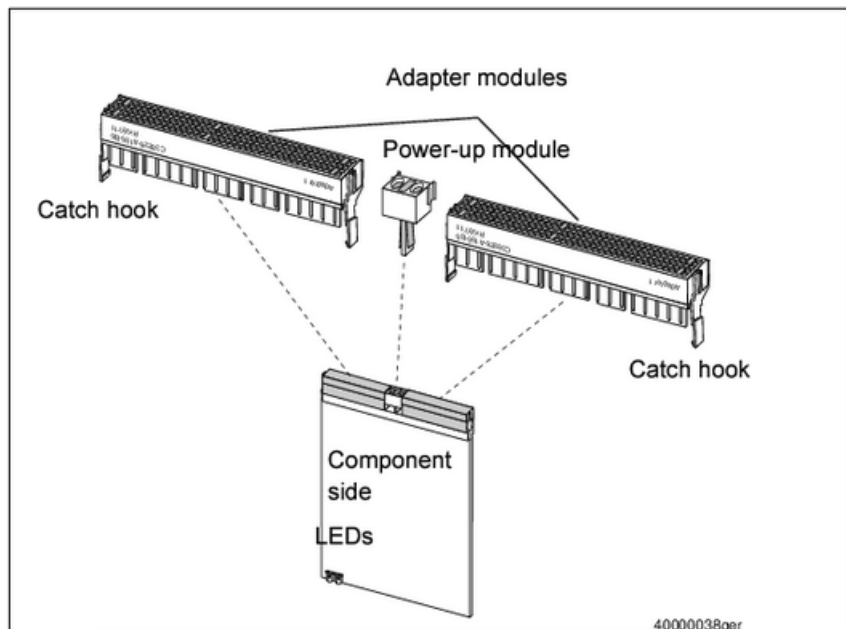
**IMPORTANT:** If the clearance between the board connector and the hot plug connector on the board is not sufficient for the module catch hook, loosen the two hot plug connector screws on the back of the board and adjust location to allow the catch hook to fit between the hot plug and the board connector.

---

10) Insert the power-up module (3) into the hot plug connector of the board.



**Figure 31: Installing SIVAPAC-to-SIPAC adapter 1 (1 of 2)**



**Figure 32: Installing SIVAPAC-to-SIPAC adapter 1 (2 of 2)**

## 4.4 Installing Shielding Covers

In order to protect the system from external disturbances, shielding covers must be installed at the following positions in the following cases:

- On the front in the case of boards without a connection option
- On the front and the rear in the case of blank board slots

The shielding covers are installed as follows:

- 1) Insert the two bottom pins on the shielding cover into the openings provided for this purpose on the slide-in shelf.

- 2) Now push the shielding cover in the direction of the board until it locks into position (refer to [Figure 5](#)).

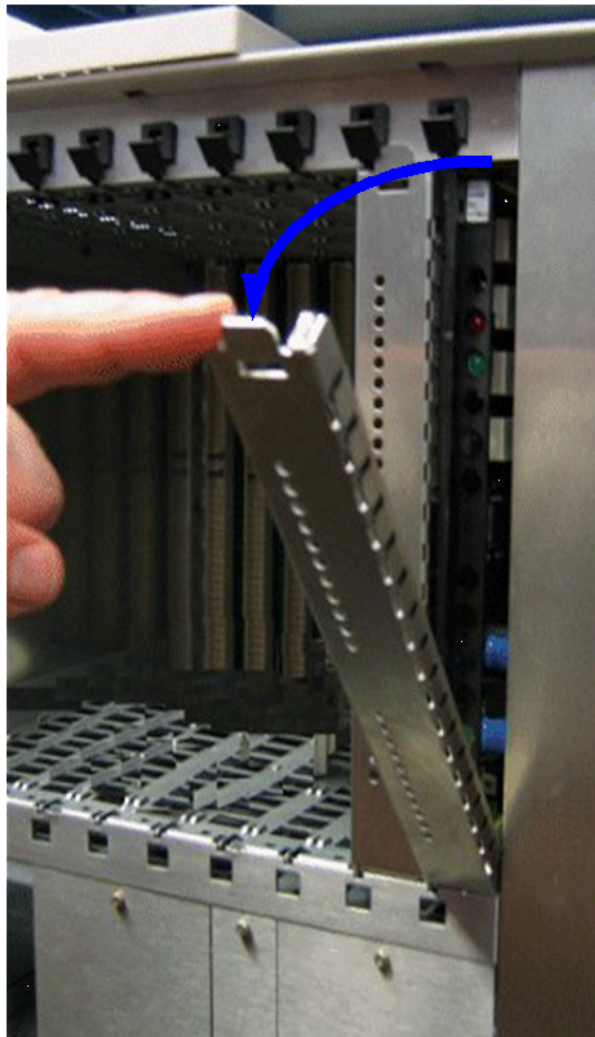


Figure 33: Installing the board shielding cover

## 4.5 Replacing the CSPCI/CCDAX in the 30" Shelf with an EcoServer

---

**NOTICE:** The system must be regenerated after the upgrade.

---

Proceed as follows to replace a CSPCI shelf with an EcoServer:

[Section 4.5.1.1, Removing the CSPCI Shelf](#)

[Section 4.5.2, Installing the EcoServer](#)

Proceed as follows to replace a CCDAX shelf with an EcoServer:

[Section 4.5.1.2, Removing the CCDAX Shelf](#)

[Section 4.5.2, Installing the EcoServer](#)

### 4.5.1 Removing the CSPCI/CCDAX Shelf

#### 4.5.1.1 Removing the CSPCI Shelf

- 1) First power down the system software.
- 2) Turn off the power supply/power supplies for the system and/or remove the mains plug from the CSPCI/CCDAX power supply.
- 3) Remove the front and rear cover of the server shelf.
- 4) Remove all cables at the front and rear of the CSPCI/CCDAX server (LTU, application, clock, V.24, ASW, ALIN cable, etc.).
- 5) Loosen the fixing screws at the rear of the CSPCI/CCDAX shelf and twist to remove.

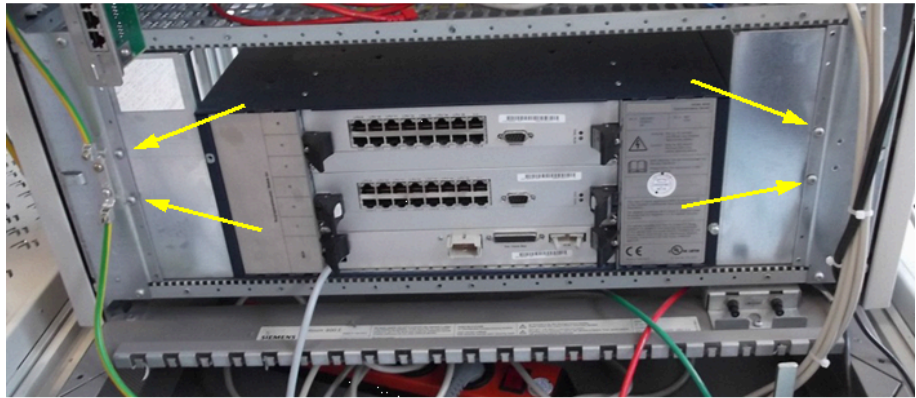
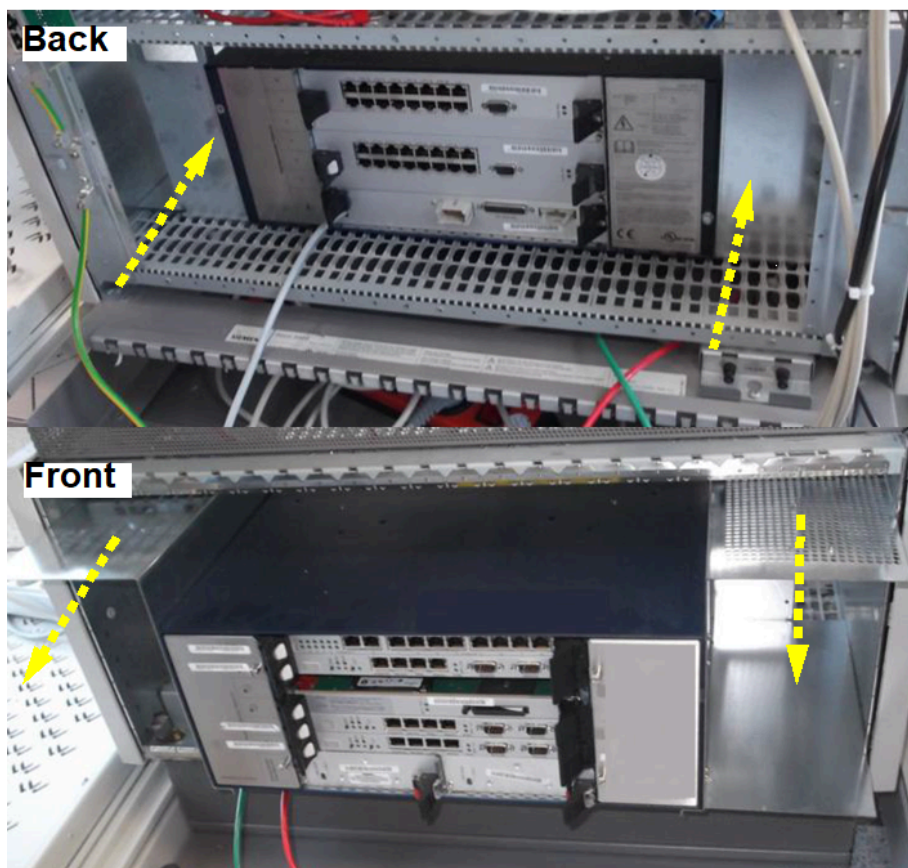


Figure 34: Removing the CSPCI fastening

- 6) Once you have removed the fixing screws on the CSPCI/CCDAX shelf, push the entire CSPCI/CCDAX shelf including mounting plates out frontwards.



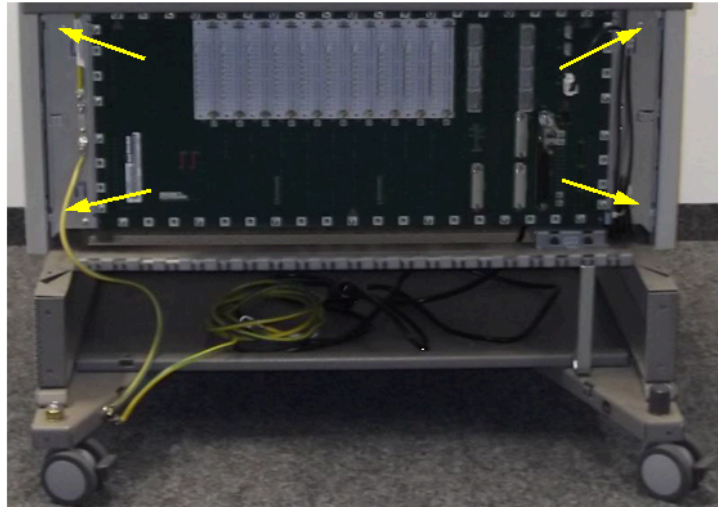
**Figure 35: Pushing the CSPCI shelf out frontwards**

- 7) Set aside all hanging cables so that the adapter frame for the EcoServer can be installed without obstructions.

#### 4.5.1.2 Removing the CCDAX Shelf

- 1) First power down the system software.
- 2) Turn off the power supply/power supplies for the system and/or remove the mains plug from the CCDAX power supply.
- 3) Remove the front and rear cover of the server shelf.
- 4) Remove all cables at the front and rear of the CCDAX server (LTU, application, clock, V.24, ASW, ALIN cable, etc.).

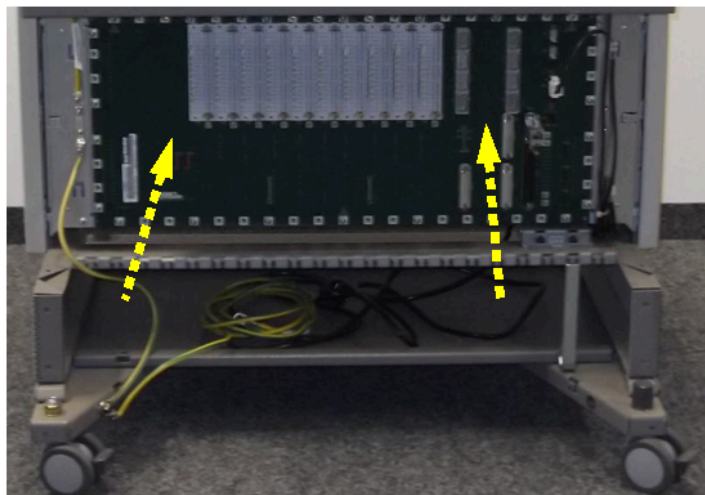
- 5) Loosen the fixing screws at the rear of the CCDAX shelf and twist to remove.



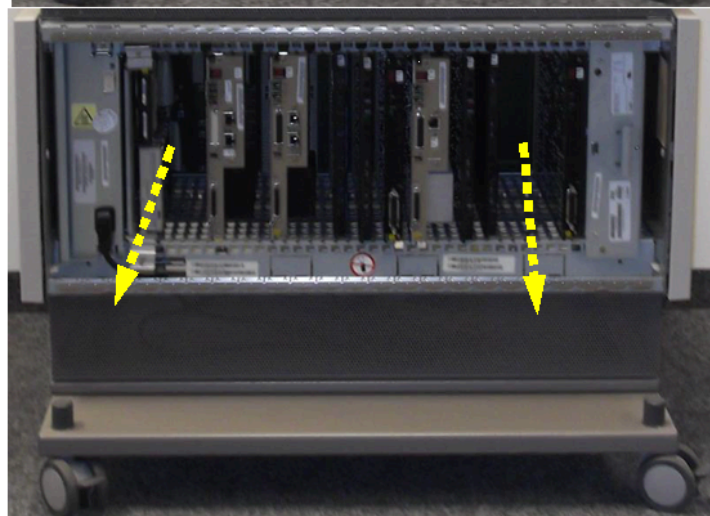
**Figure 36: Removing the CCDAX fastening**

- 6) Once you have removed the fixing screws on the CCDAX shelf, push the entire CCDAX shelf including mounting plates out frontwards.

**Back**



**Front**



**Figure 37: Pushing the CCDAX shelf out frontwards**

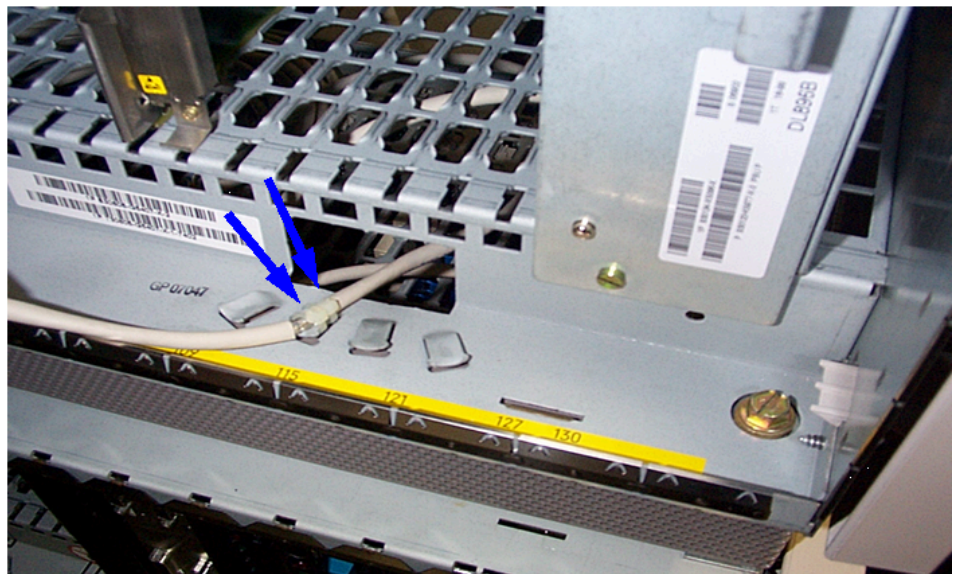
- 7) Set aside all hanging cables so that the adapter frame for the EcoServer can be installed without obstructions.

## 4.6 Shielding Connection on the Opening of the LTU Frame

---

**NOTICE:** The shield of all front cables (except network cables and optical fiber cables) must be secured to the frame with two cable ties at the shelf opening.

---



**Figure 38: Securing the cable shield**

---

**IMPORTANT:** System cables with pre-stripped sections must be used for LTU frames.

---

## 4.7 Attaching the Ferrite

A ferrite core must be attached to the AC mains cable and DC connecting cables in order to prevent the system being impacted by external atmospheric interferences (radiation) (not for EcoServer).

**Part numbers:**

- Ferrite core: C39022-Z7000-C16
- System box: S30807-U6625-X

### 4.7.1 Attaching the Ferrite Core to the AC Mains Cable

- 1) Lay the opened ferrite core below the mains cable as close as possible to the housing.



Figure 39: Opened ferrite core below AC cable

- 2) Take the mains cable and make a loop so that the mains cable runs twice through the ferrite core.

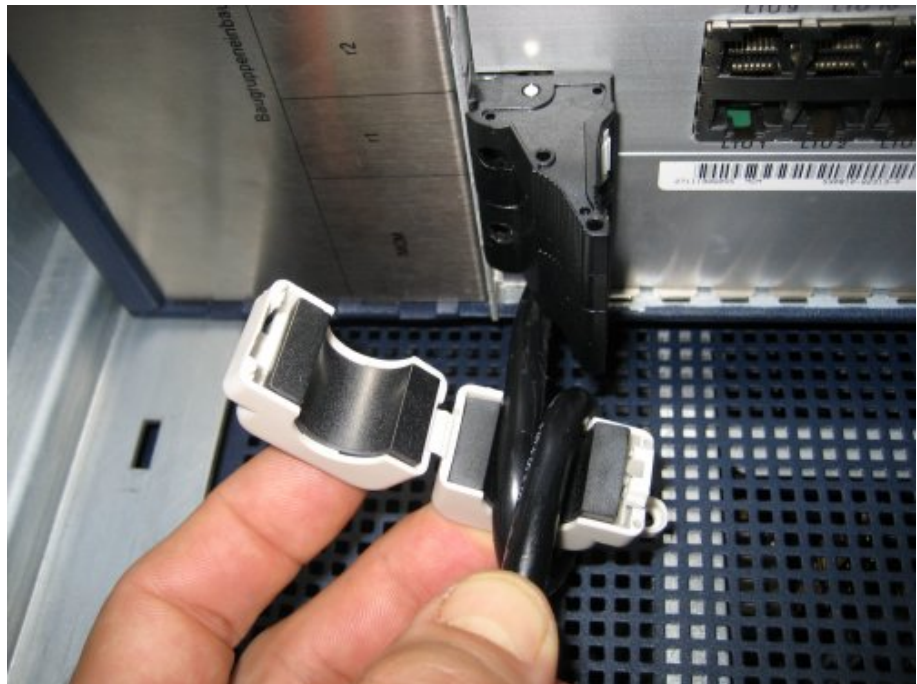


Figure 40: Looping the AC cable through the ferrite core

- 3) Now close the ferrite core by pressing the two halves together without clamping the cable. The ferrite core must be closed fully (see [Section 4.7.3, "Description and Handling of Ferrite Core"](#)).



Figure 41: Closed ferrite core with AC cable

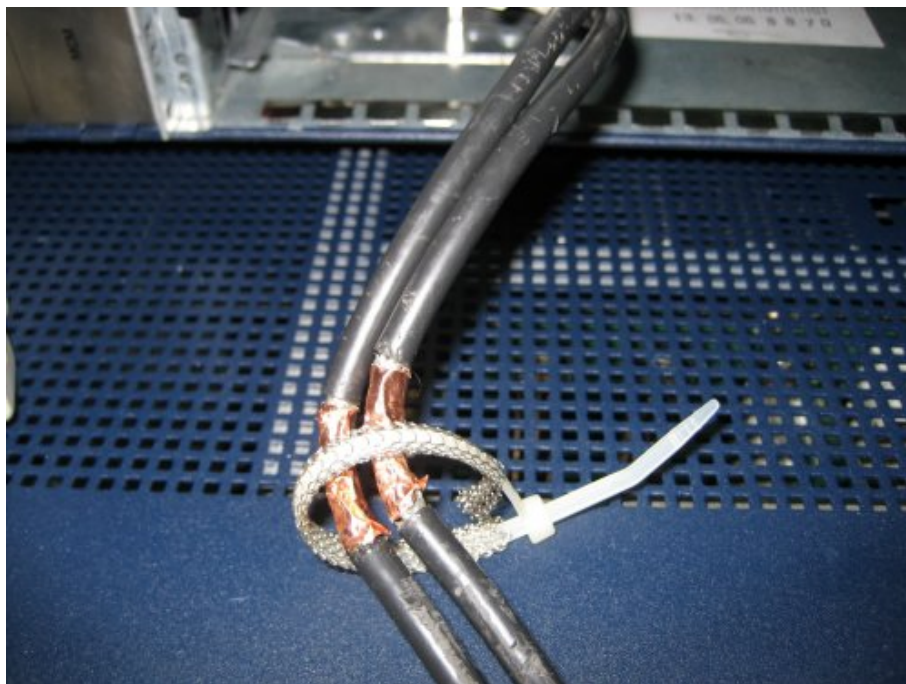
## 4.7.2 Attaching the Ferrite Core to the DC Cables

- 1) Strip away the cable insulation from the two DC cables up to the shield (if not already done in advance).



**Figure 42: Stripped DC cable**

- 2) Use a cable tie (part no.: PNQ:5VC1036026) with metal shield in order to make a 360° shield connector and secure this around the two DC cables.



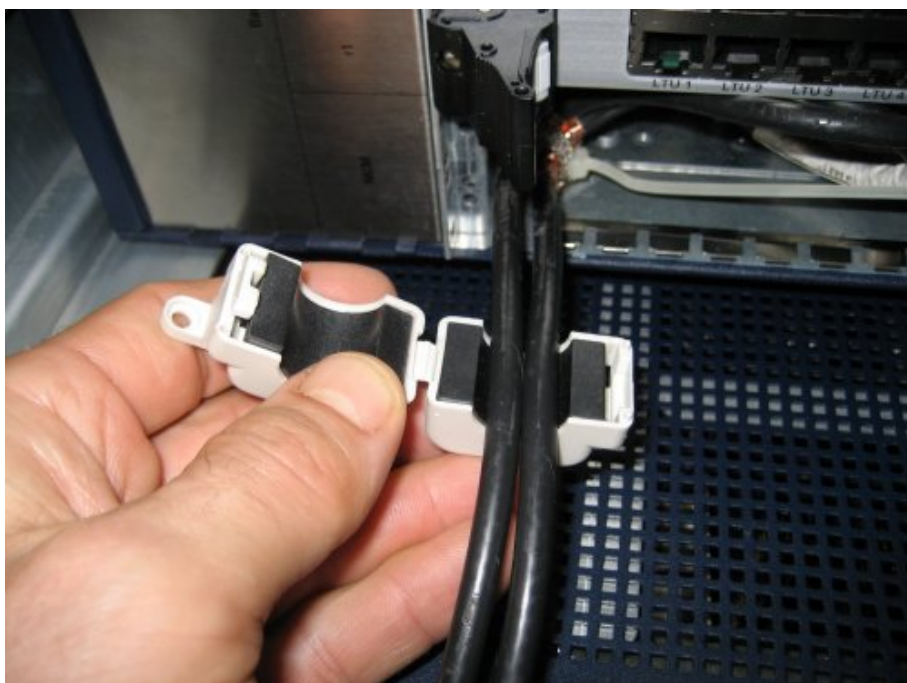
**Figure 43: Cable tie with metal shield**

- 3) Secure the DC cable shield to the cord grip provided on the housing for this purpose (6) using the cable tie.



**Figure 44: DC cable shield on housing**

- 4) Lay the opened ferrite core below the mains cable as close as possible to the housing.



**Figure 45: Opened ferrite core below DC cable**

## Installation

- 5) Take the DC cables and make a loop so that the two DC cables runs twice through the ferrite core.



**Figure 46: Looping the DC cables through the ferrite core**

- 6) Now close the ferrite core by pressing the two halves together without clamping the cable. The ferrite core must be closed fully (see [Section 4.7.3, "Description and Handling of Ferrite Core"](#)).



**Figure 47: Closed ferrite core with DC cables**

### 4.7.3 Description and Handling of Ferrite Core

A ferrite core from the company Wuerth is used (part number: 7427154). The ferrite core comes with a key tool, which is used to open the ferrite core.



**Figure 48: Key tool and opened ferrite core**

To close the ferrite core, press the two halves firmly together without clamping the cable. The ferrite core must be closed fully.



**Figure 49: Key tool and closed ferrite core**

---

**NOTICE:** The ferrite core must be closed fully, with no air slots or air gaps. You can check this by looking sideways through the ferrite core. No air slot should be visible and none of the cables should be clamped between the two halves of the ferrite core.

---

To open the ferrite core, press the key tool firmly into the slot on the housing of the ferrite core until the housing opens. Then simply press open the two halves.

## Installation



**Figure 50: Pressing the key tool into the housing of the ferrite**

## 5 Installation Variants

This chapter provides schematic representations for the various OpenScape 4000 system installations. For illustrations or IPDA installations, refer to the associated chapter. Unless otherwise noted, all illustrations apply to both U.S. and I.M. installations.

### 5.1 30" Standard Cabinet Installation

This section describes the different ways to install the cabinets depending on the individual requirements of each customer.

---

**IMPORTANT:** Each cabinet, including the front cover, forms a shielded unit. Cabinets should be locked while the system is running and the cover should be replaced following testing and maintenance.

---

#### 5.1.1 Single-Cabinet Installation

---

**IMPORTANT:** The dimensions shown in these illustrations are minimum dimensions in millimeters (mm).

---

Figure shows a diagram of a single-cabinet installation.

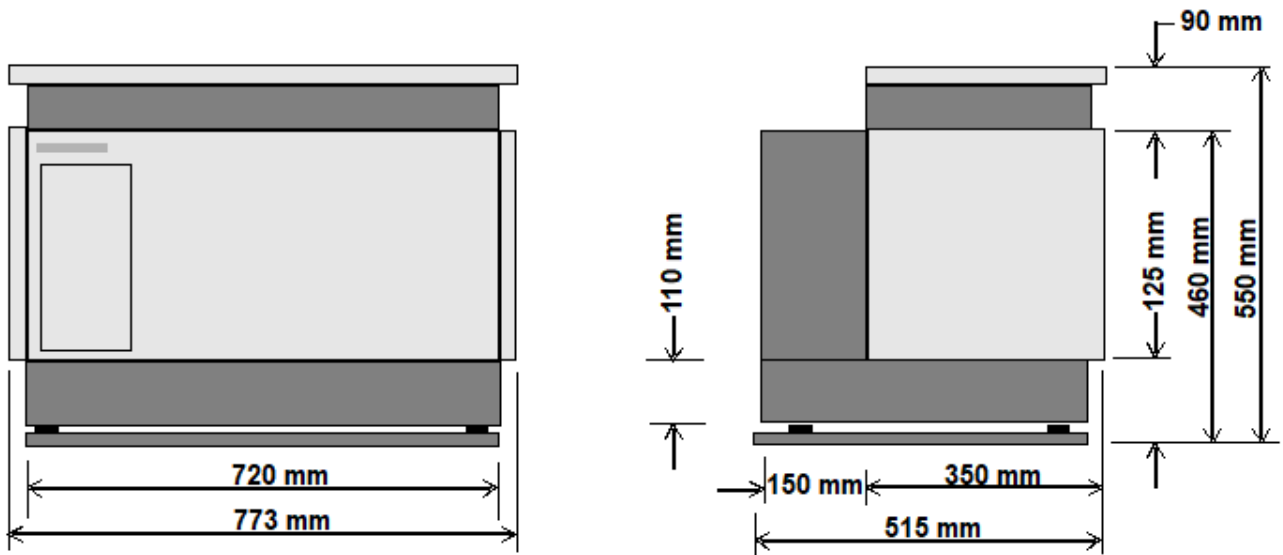


Figure 51: Single-cabinet installation

## 5.2 Multiple Cabinet Installation

**IMPORTANT:** The dimensions shown in the following illustration are minimum dimensions in millimeters (mm).

Figure shows a diagram of a multiple cabinet installation.

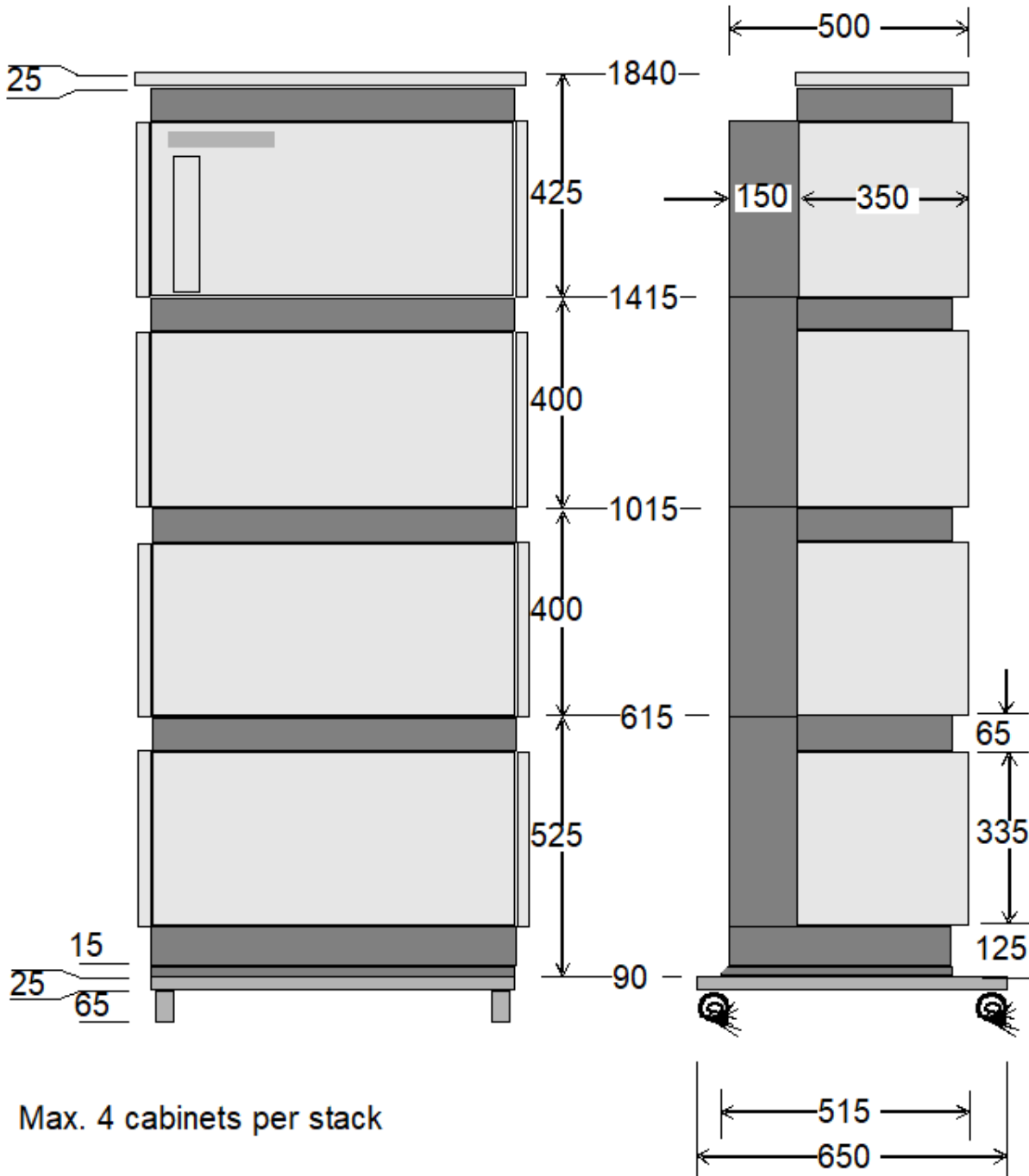


Figure 52: Multiple cabinet installation

### 5.3 AC-to-DC Power Box Installation

---

**IMPORTANT:** The AC power box is called a unit alternating current distribution (UACD) power supply.

---

---

**IMPORTANT:** The dimensions shown in the following illustration are minimum dimensions in millimeters (mm).

---

Figure shows the dimensions of the UACD.

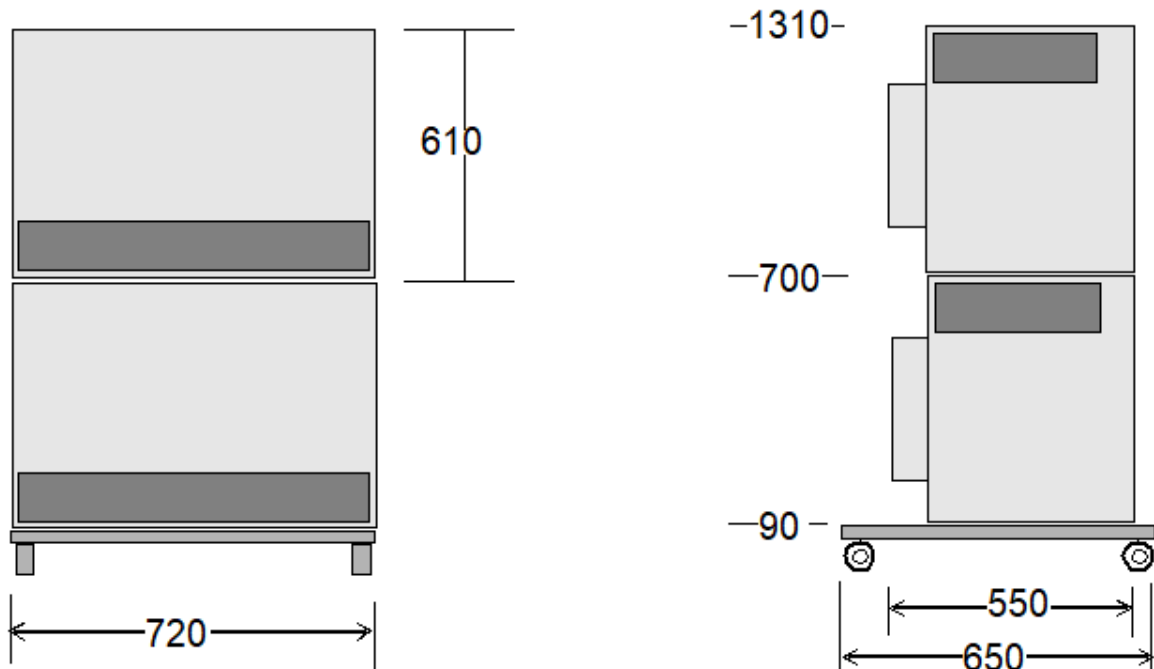


Figure 53: UACD

### 5.4 DC-to-DC Power Box Installation

---

**IMPORTANT:** The DC power box is known as a unit direct current distribution (UDCD) power supply.

---

---

**IMPORTANT:** The dimensions shown in the following illustration are minimum dimensions in millimeters (mm).

---

Figure shows the dimensions of a 2-stack UDCD.

**Installation Variants**  
Free-Standing Installation

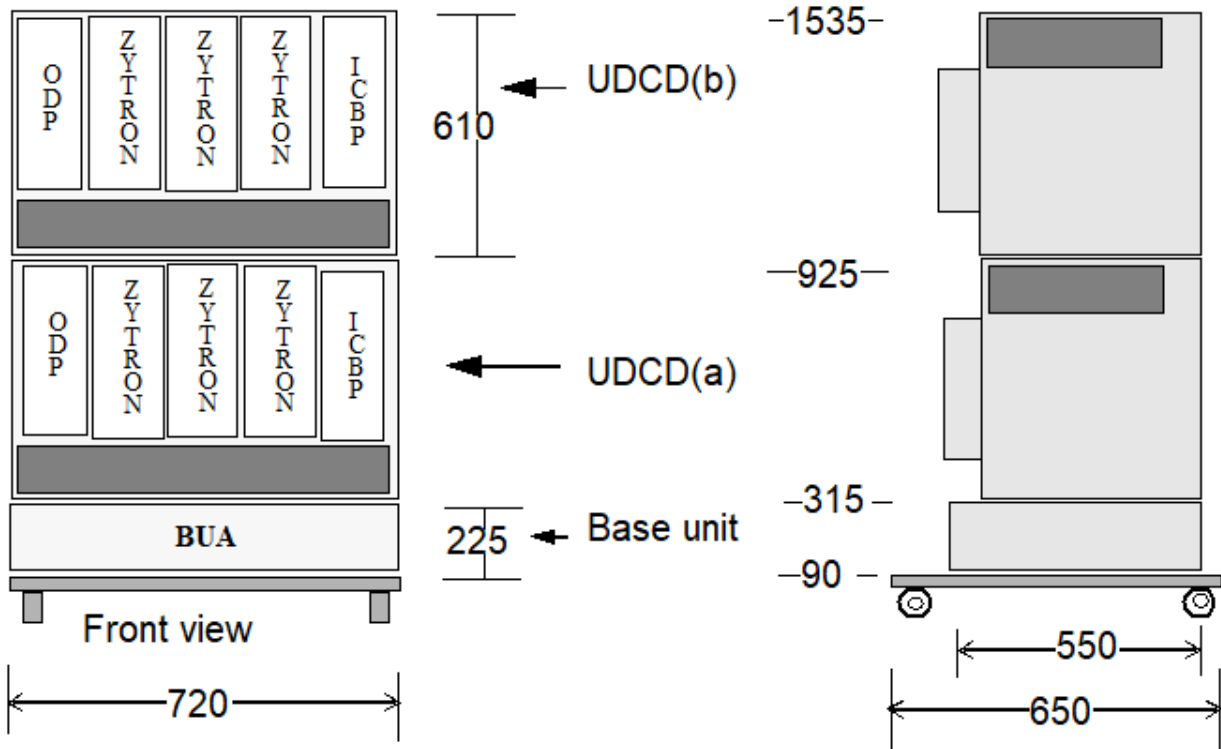


Figure 54: UDCD

## 5.5 Free-Standing Installation

---

**IMPORTANT:** The CSPCI box, including the front cover, forms a shielded unit. Free slots must be covered.

---

### 5.5.1 CSPCI Box/EcoServer in UCS Shelf, Stack 1

In this example, the common control cabinet is installed in the UCS shelf of the first stack.

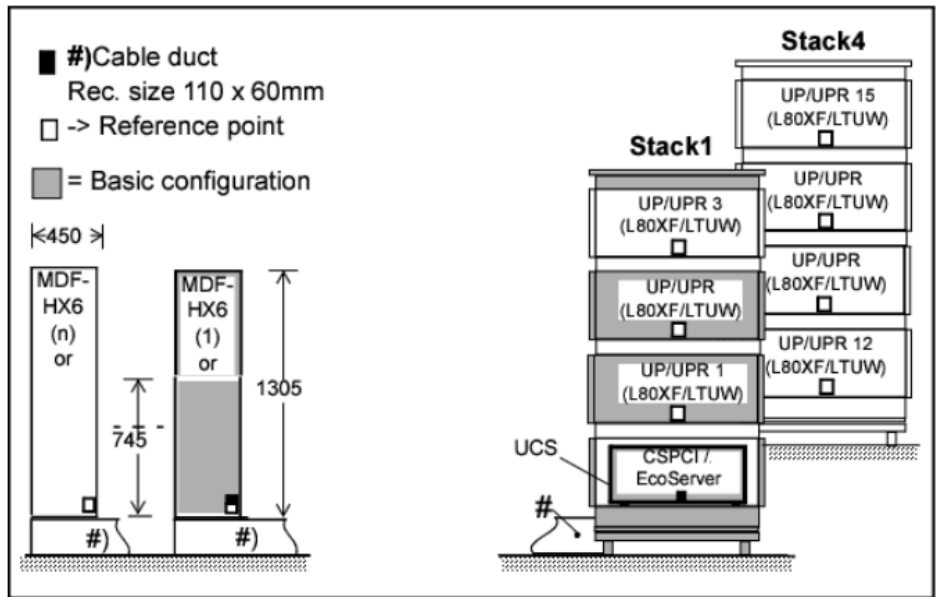


Figure 55: CСПCI box in UCS shelf, stack 1

### 5.5.2 CСПCI Box/EcoServer in External 19" Cabinet

In this example, the common control cabinet is installed in a 19" external cabinet.

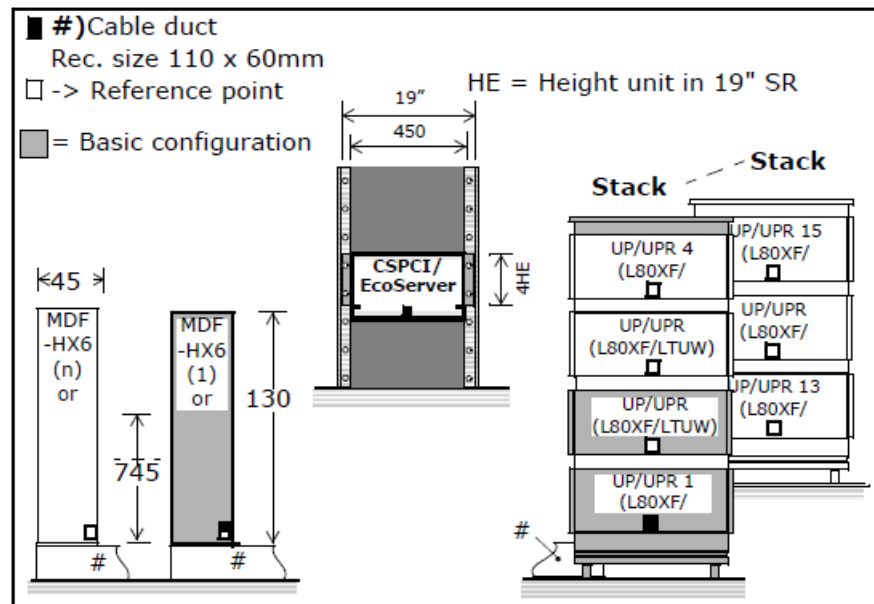


Figure 56: CСПCI box in external 19" cabinet

### 5.5.3 OpenScape 4000 Free-Standing Installation (30" Maximum Configuration)

Figure shows a diagram of a free-standing installation (viewed from above). This diagram applies to the U.S. with the exception of the MDF cabinets.

The maximum AC-powered system configuration consists of four 4-stack cabinets and one UACD stack with two power box units.

The maximum DC-powered system configuration consists of four 4-stack cabinets and two UACD stacks with two power box units each.

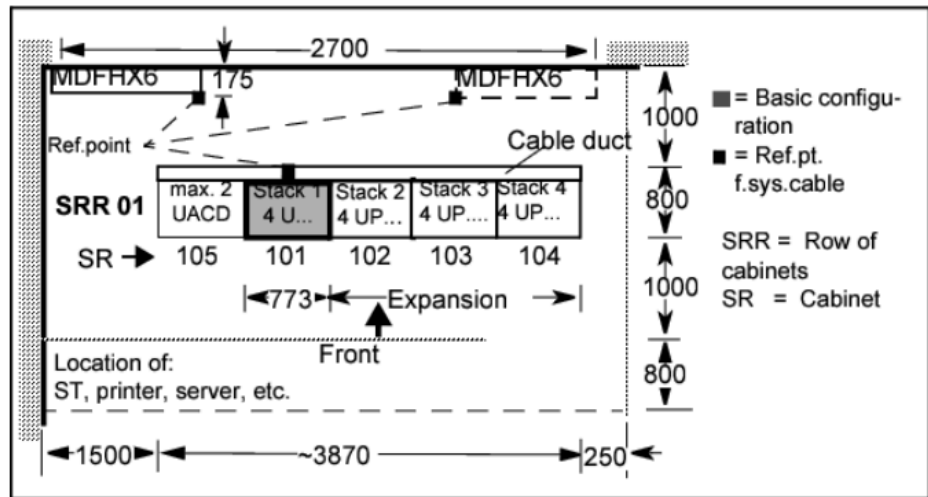


Figure 57: OpenScape 4000 free-standing installation (30" variant)

### 5.6 Cabling Diagram, I.M.

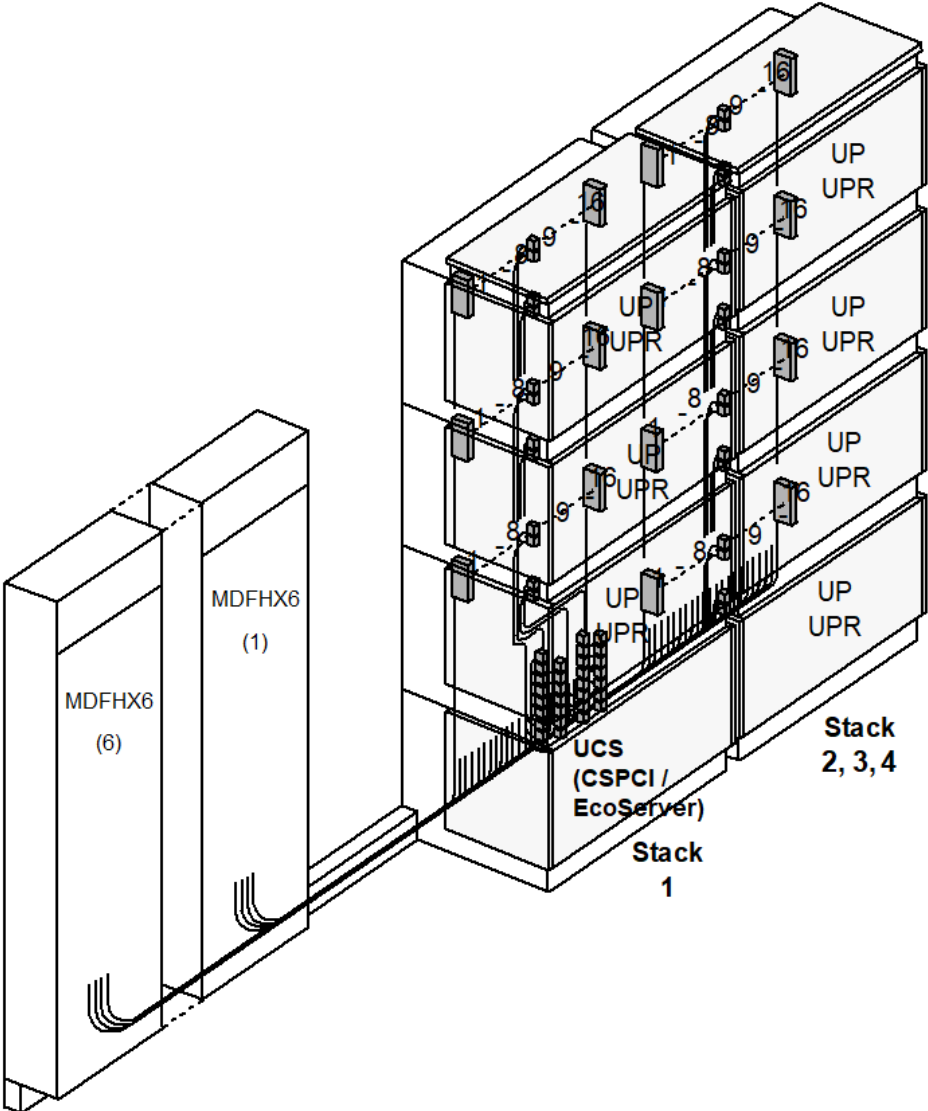


Figure 58: Cable routing OpenScape 4000 (30" variant)

### 5.7 Shelf Configuration

This section shows board and power supply locations in the CSPCI common control unit and expansion boxes.

#### 5.7.1 EcoServer

The EcoServer is designed as an autonomous 19" solution. The system is used as a standalone system or in (19" and 30") cabinets.



The "OpenScape 4000 EcoServer" variant with AC/DC power supply has been awarded the ENERGY STAR®.

---

**NOTICE:** Please refer to the hardware description in the "OpenScape 4000 Service Manual" for information on replacing the individual components.

---



**CAUTION:** It is not permitted to open the housing cover. If the seal on the housing is removed or broken, the device warranty is automatically invalidated.

---



Figure 59: EcoServer

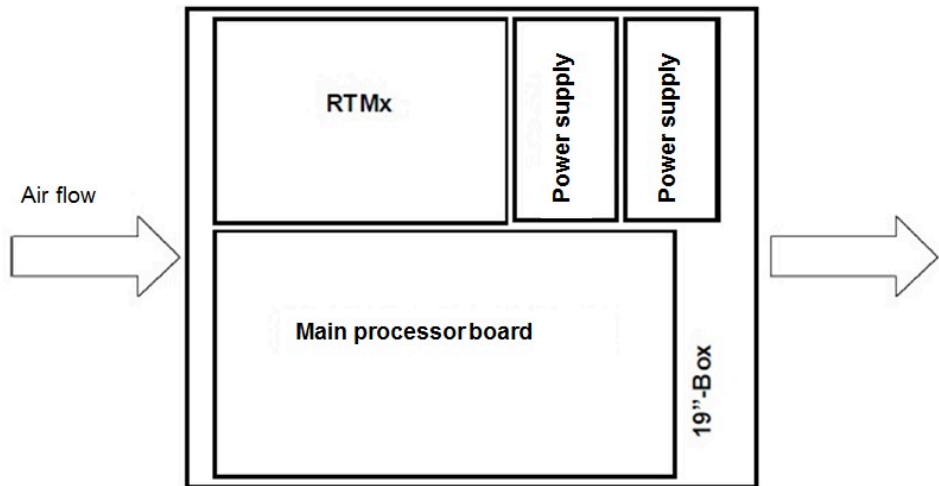


Figure 60: System overview

### 5.7.1.1 Standalone Installation



Figure 61: Standalone (simplex)



Figure 62: Standalone (duplex)

### 5.7.1.2 19" Installation

---

**NOTICE:** There are no installation requirements to be noted for the EcoServer for the 19" installation. It can be installed at any height in the cabinet. It must simply be ensured with a duplex variant that both EcoServers are installed directly above one another since the cross-connect cable that connects the two EcoServers is only 130mm long.

---

**NOTICE:** In case of deviations from the recommended installation variant, make sure that the length of the LTU cable between the EcoServer and expansion shelf is adequate. It can happen with some installation variants that the LTU cables supplied are too short (e.g. if the EcoServer is installed separately from the expansion shelf in a different room).

---

**CAUTION:** In the case of cabinet installation, the EcoServer must not be weighed down with other components/devices. The installation accessory is only designed for the EcoServer and cannot bear the weight of additional hardware.

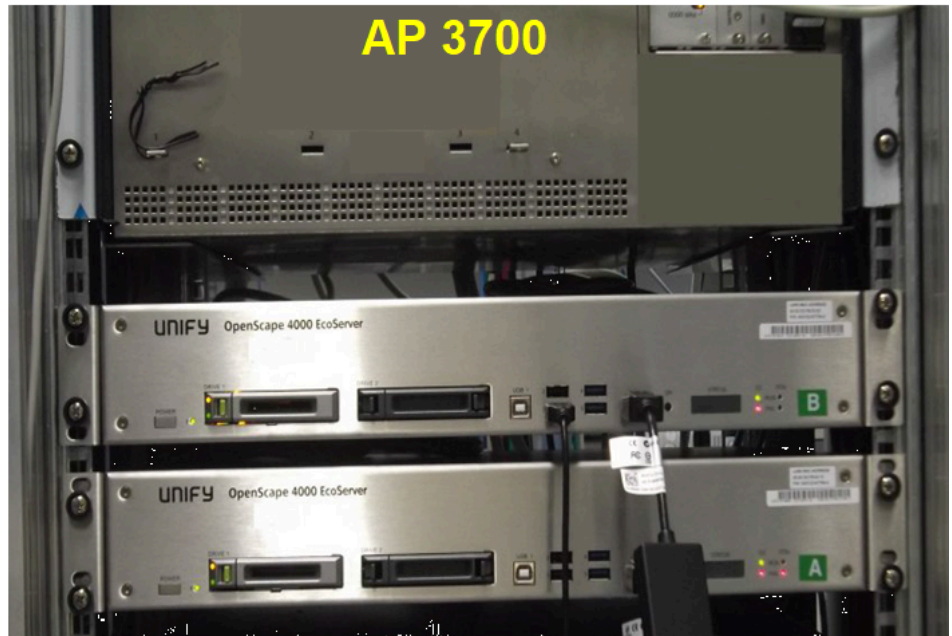


Figure 63: Example of 19" installation with EcoServer (duplex) and AP3700

### 5.7.1.3 30" Installation

**NOTICE:** With the 30" variant, the EcoServer is installed at the same position at the bottom of the first cabinet as otherwise the case with the CSPCI and CCDAX.

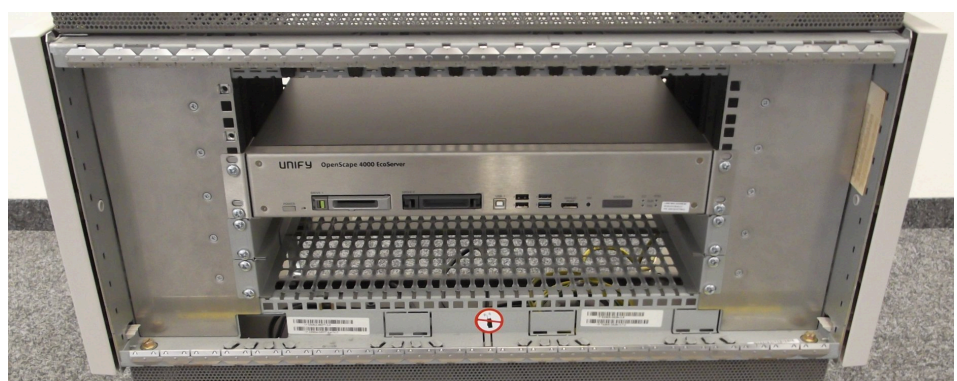


Figure 64: 30" installation

### 5.7.2 UPR Cabinet

---

**IMPORTANT:** The unit peripheral redundant (UPR) cabinet is otherwise known as the LTUW cabinet.

---

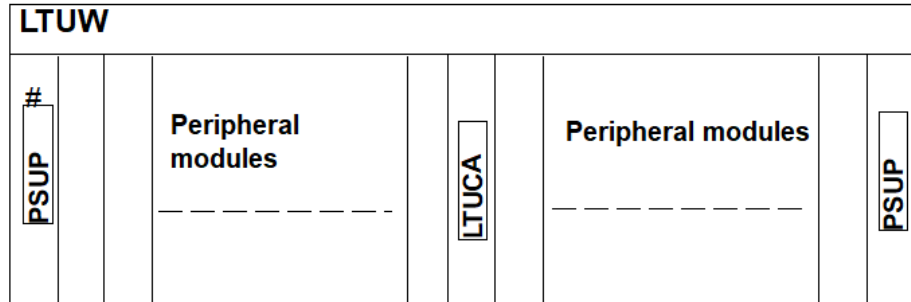


Figure 65: UPR cabinet

### 5.7.3 Unit Peripheral Nonredundant Cabinet

---

**IMPORTANT:** The unit peripheral nonredundant (UP) cabinet is otherwise known as the L80XF cabinet.

---

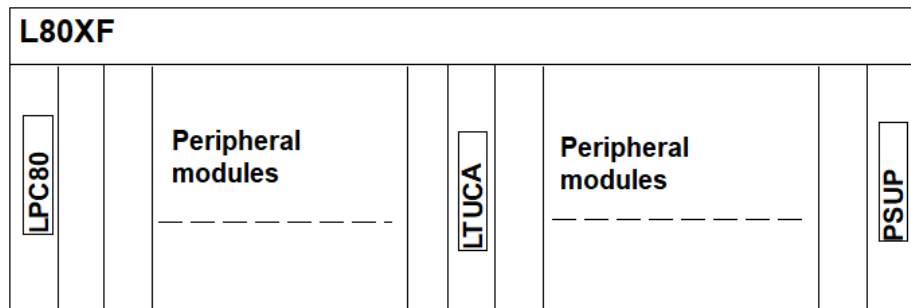


Figure 66: UP Cabinet

### 5.7.4 AP 3700-9

Part number: S30805-G5412-X

**Component placement (front side)**

- Slot 1-5: Peripheral boards
- Slot 6: Common control unit NCUI2 (AP3700-9)
- Slot 7-10: Peripheral boards
- Max. 3 LUNA 2/LUNA 3 power supplies

---

**IMPORTANT:** Only two power supplies are needed. The third LUNA2 is used for a redundant power supply.

LUNA3 is fully compatible with this slot configuration and supports the same functional placement as LUNA2.

- CompactPCI cassette (Survivability Server), only used in AP 3700-9 (OpenScape 4000)

**IMPORTANT:** This Compact PCI cassette can be installed in the shelves as an optional emergency server (Survivability Server).

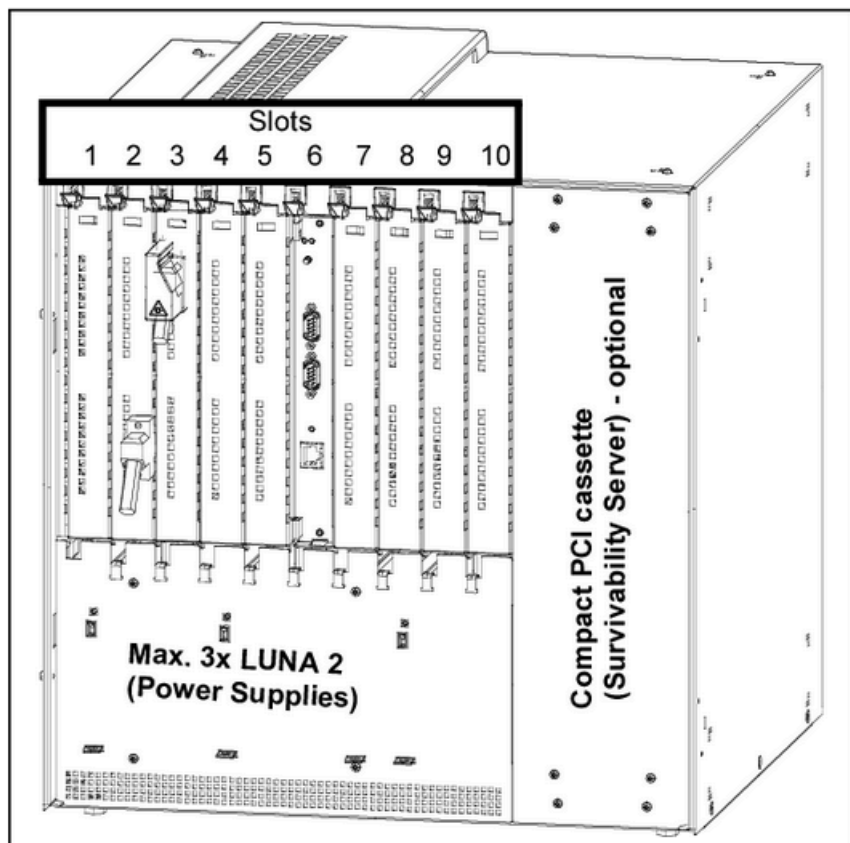


Figure 67: AP 3700-9 front view

**Component placement (back side) with patch panels**

- Slot 10-7: Patch panels (8-, 20- and 24-port RJ45 connectors/CHAMP connectors)
- Slot 6: Board for power connection (DC above/AC below)

## Installation Variants

- Slot 5-1: Patch panels (8-, 20- and 24-port RJ45 connectors/CHAMP connectors)

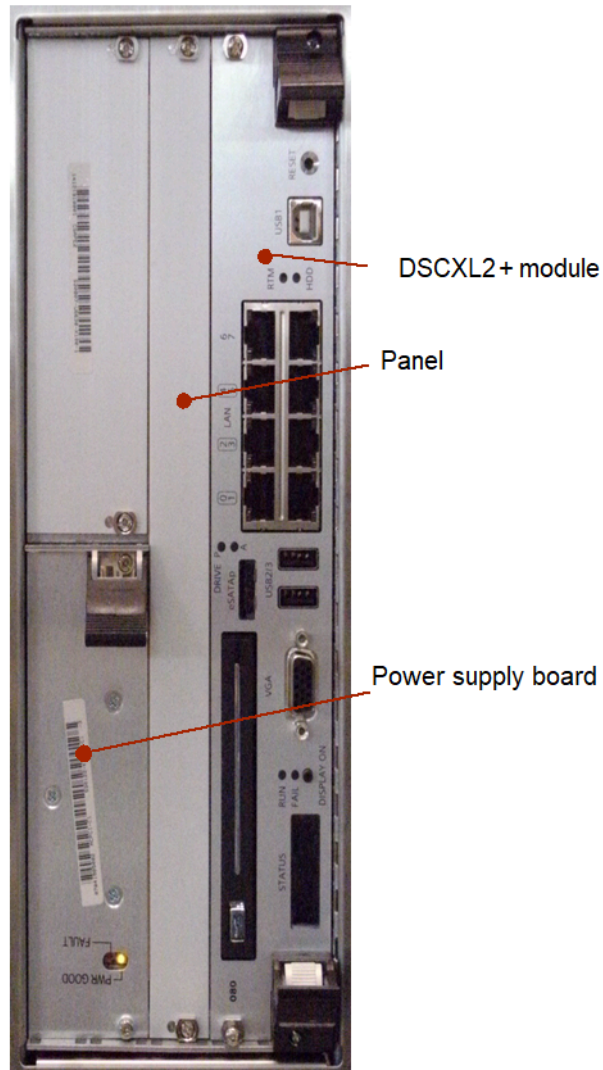


Figure 68: Survivability Server slide-in shelf

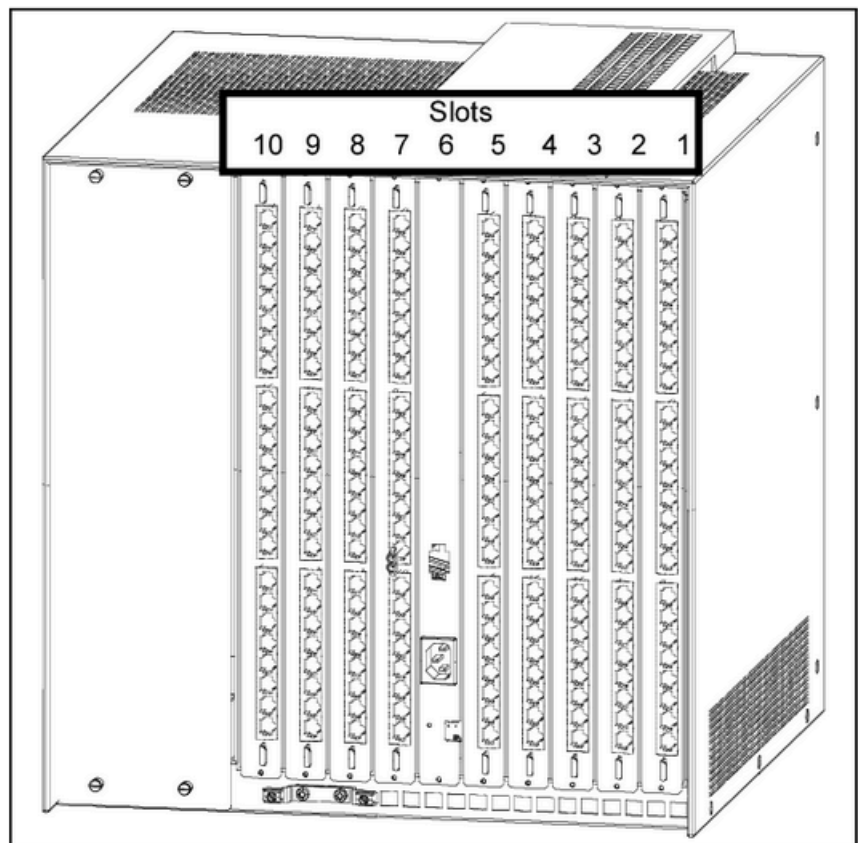


Figure 69: AP 3700-9 (back view) with patch panels

### 5.7.5 AP 3700-13 (Expansion Cabinet)

Part number: S30805-G5413-X

#### Component placement (front side)

- Slot 1-6: Peripheral boards
- Slot 7: Central control board LTUCA (AP3700-13)/with (H3800BB) not occupied
- Slot 8-14: Peripheral boards
- max. 4 LUNA 2/ LUNA 3 power supplies

---

**IMPORTANT:** Only three power supplies are needed. The fourth LUNA2/LUNA 3 is used for a redundant power supply.

---

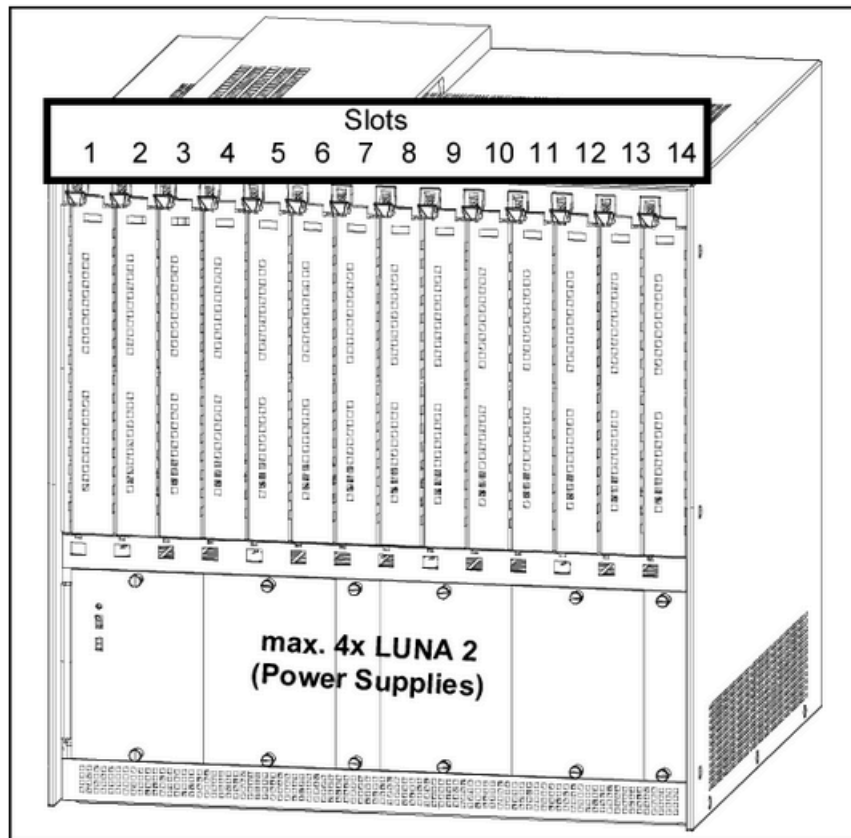


Figure 70: AP 3700-13 front view

**Component placement (back side) with patch panels**

- Slot 14-8: Patch panels (8-, 20- and 24-port RJ45 connectors/CHAMP connectors)
- Slot 7: Board for power connection (DC above/AC below)
- Slot 6-1: Patch panels (8-, 20- and 24-port RJ45 connectors/CHAMP connectors)

- Ground connector

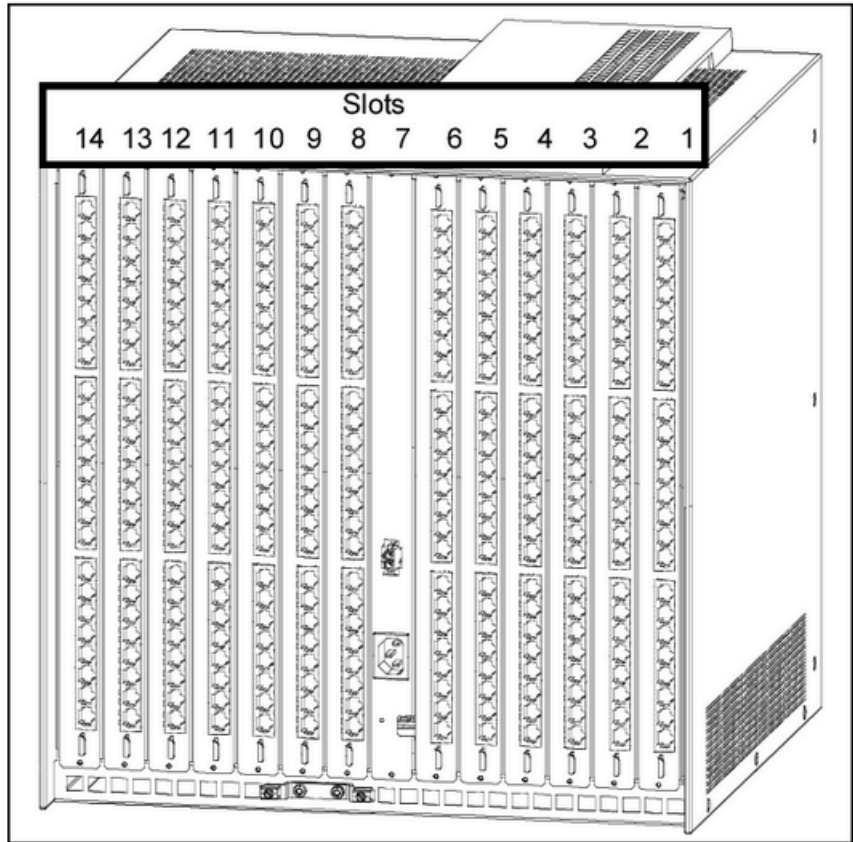


Figure 71: AP 3700-13 (back view) with patch panels

### 5.7.6 Redundant Power Box Stacks

UACD 2				
PDPX2 Stack 3/ 4	LPC 1	LPC 2	LPC 3	ACDPX
UACD 1				
PDPX2 Stack 1/2	LPC 1	LPC 2	LPC 3	ACDPX

Figure 72: Redundant power box stacks

## Installation Variants

### Installation with AP 3700 Cabinets

## 5.8 Installation with AP 3700 Cabinets

Depending on the system configuration, the following connections are possible when adding AP 3700 cabinets to a OpenScape 4000 system.

### 5.8.1 Connecting AP 3700-9 to L80XF/LTUW

In this example, an AP 3700 basic cabinet with 9 peripheral boards is connected to an OpenScape 4000 system.

Using an NCU14 board, the AP 3700 base cabinet is connected to an STMI4 board on an L80XF or LTUW shelf in a OpenScape 4000 system (see [Figure 23](#)).

### 5.8.2 Connecting AP 3700-13 to CСПCI/EcoServer

In this example, an AP 3700 expansion cabinet with 13 peripheral boards is connected to a OpenScape 4000 system. This expansion can only be done with a 19" cabinet.

The connection is via a cable from the RTM board/RTMx module on the CСПCI/EcoServer processor shelf to the LTUCA board in the expansion cabinet (see [Figure 23](#)).

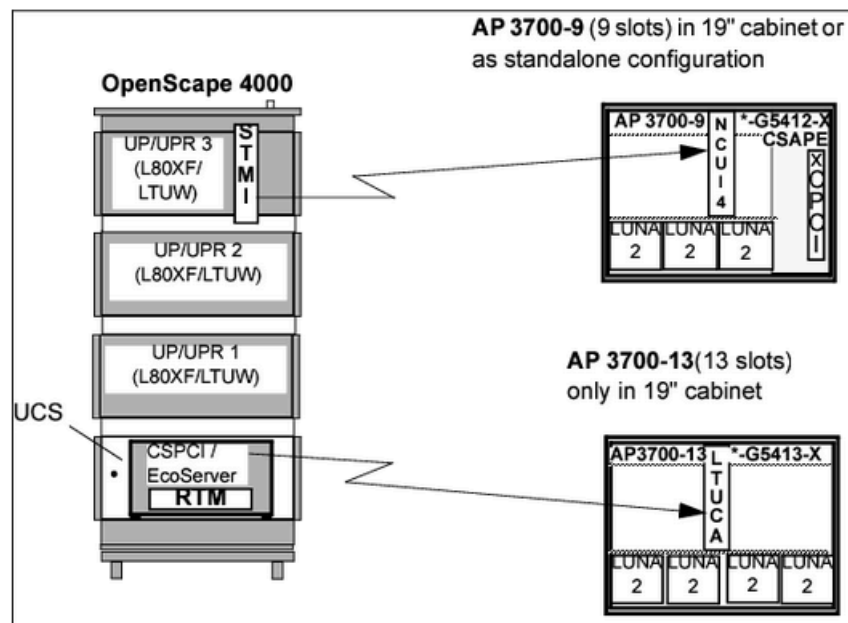


Figure 73: AP 3700 connections

### 5.8.3 AP 3700 Configuration Rules and Examples with 19" Cabinets/Open Racks

The rules apply to the installation of the CСПCI, AP 3700 IP, AP 3700 components and DCDR in standard commercial 19" cabinets or open 19" racks.

---

**NOTICE:** There are no installation requirements to be noted for the EcoServer. It can be installed at any height in the cabinet. See also the information in [Section 5.7.2.2, 19" Installation](#)".

---

**NOTICE:** The installation instructions below apply equally for closed cabinets and open racks.

---

### 5.8.3.1 Suitable Cabinet Models

The standard commercial 19" cabinets used for server and network applications in the IT sector are suitable for installing the OpenScape 4000 components.

The elements installed in the cabinet must be accessible from the back and front.

Cabinets that allow 19-inch components to be installed from the back and front should be used ( $\geq 4$  vertical struts).

In accordance with the relevant vendor's selected rack program, the following parts and devices must/can be obtained from the rack vendor:

- Fixing screws/material for installing devices/cabinets;
- Sliding rails/support rails;
- Wire feeding elements and cable management;
- Multiple socket busbars/outlets;
- Distribution cabinets/elements and patch panels for LAN connections;
- Fan unit(s) incl. connecting cables;
- Other accessories, for example, additional angles, shelves (ensure air permeability), C-rails, etc.

In line with the planned configuration, cabinets with the appropriate number of rack units (Us, 1 U = 44.45 mm) should be selected.

A typical cabinet width of 700 mm ...800 mm and height of at least 600 mm is recommended. Greater cabinet depths (800 mm ...900 mm) make installation easier and cable management more convenient and also allow more components to be installed at the back of the cabinet. The space between the cabinet rows should typically be the same as the width of the cabinet.

If AP 3700 IP and AP 3700 boards are to be installed, the cabinet must have sliding rails/supporting rails with a minimum load-bearing capacity of 40 kg.

The sliding rails can be obtained from the rack manufacturer.

The 19" installation brackets supplied should be used to fix the components to the cabinet struts.

To ensure sufficient heat removal, the cabinets should be arranged in accordance with the following sample configurations.

CSPCI requires 4 HEs and should preferably be placed in the bottom of the rack. Enough space should be allowed for ventilation (air drawn in from the left, air escapes on the right).

---

**NOTICE:** If an EcoServer is used instead of the CSPCI, there are no installation requirements to be noted for the EcoServer. It can be installed at any height in the cabinet. It must simply be

ensured with a duplex variant that both EcoServers are installed directly above one another since the cross-connect cable that connects the two EcoServers is only 130mm long.

---

The AP 3700-\* requires 11 HEs (10 HEs + free space).

Two AP 3700-\* boards can be installed without mandatory ventilation (without a fan unit).

If there are more than two AP 3700-\* boards, a 19" fan unit (1 U) must be used.

Ventilation should be provided across the whole area.

The required air flow rate of at least 600 m<sup>3</sup>/h should be ensured.

If necessary, it is possible to install a second fan unit (if redundancy is desired but not mandatory).

A minimum clearance of 2 HEs should be allowed between the CSCPI and the AP 3700-\* board

The cabinets should be chosen and configured so that there is sufficient air circulation.

---

**IMPORTANT:** As the individual cabinets already satisfy EMC requirements, the use of shielded racks is not necessary.

---

19" connector strips in the appropriate country-specific version should be provided for connection to the AC power supply (230V or 115 V).

Power requirement for EcoServer: 1A/115 V, 0,5A/230V

Power requirement for CSCPI: 4A/115V 2A/230V

Power requirement for AP 3700 IP: 6A/115V, 3A/230V

Power requirement for AP 3700: 8A / 115V, 4A/230V

Power requirement for survivability unit: 4A/115V, 2A/230V

Power requirement for fan unit: see manufacturer's information

In the case of DC systems (48V), you must ensure that a fused 16 A connection is used.

Separate protective grounding must be performed radially from the external ground busbar to each individual rack (minimum cross-section 102). All ground wires in the rack should be routed to the to the central ground connection point in the relevant cabinet. DC power lines must be shielded for EMC reasons.

The shielding should be removed on both sides.

5.8.3.2 Sample Configuration AP 3700 or AP3700 IP in a Cabinet with 25 Rack Units

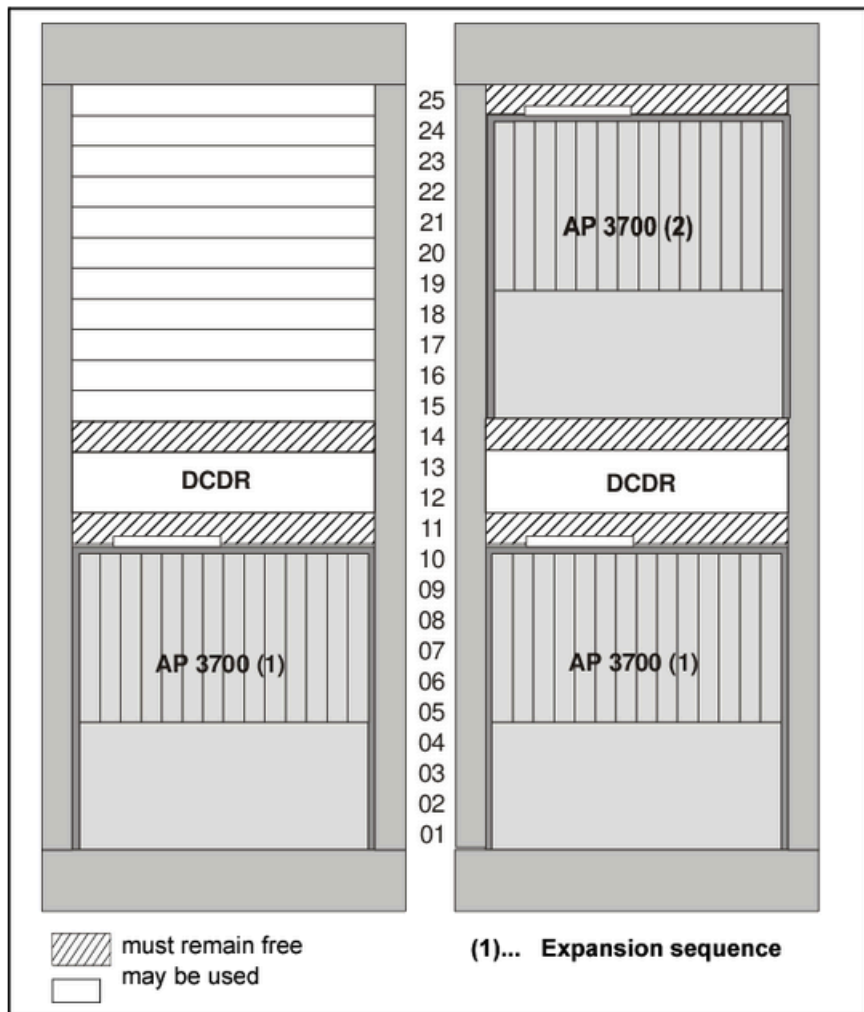


Figure 74: Installing AP 3700/AP 3700 IP in a cabinet with 25 rack units

5.8.3.3 Sample Configuration CSPCI with AP 3700 in a Cabinet with 37 Rack Units

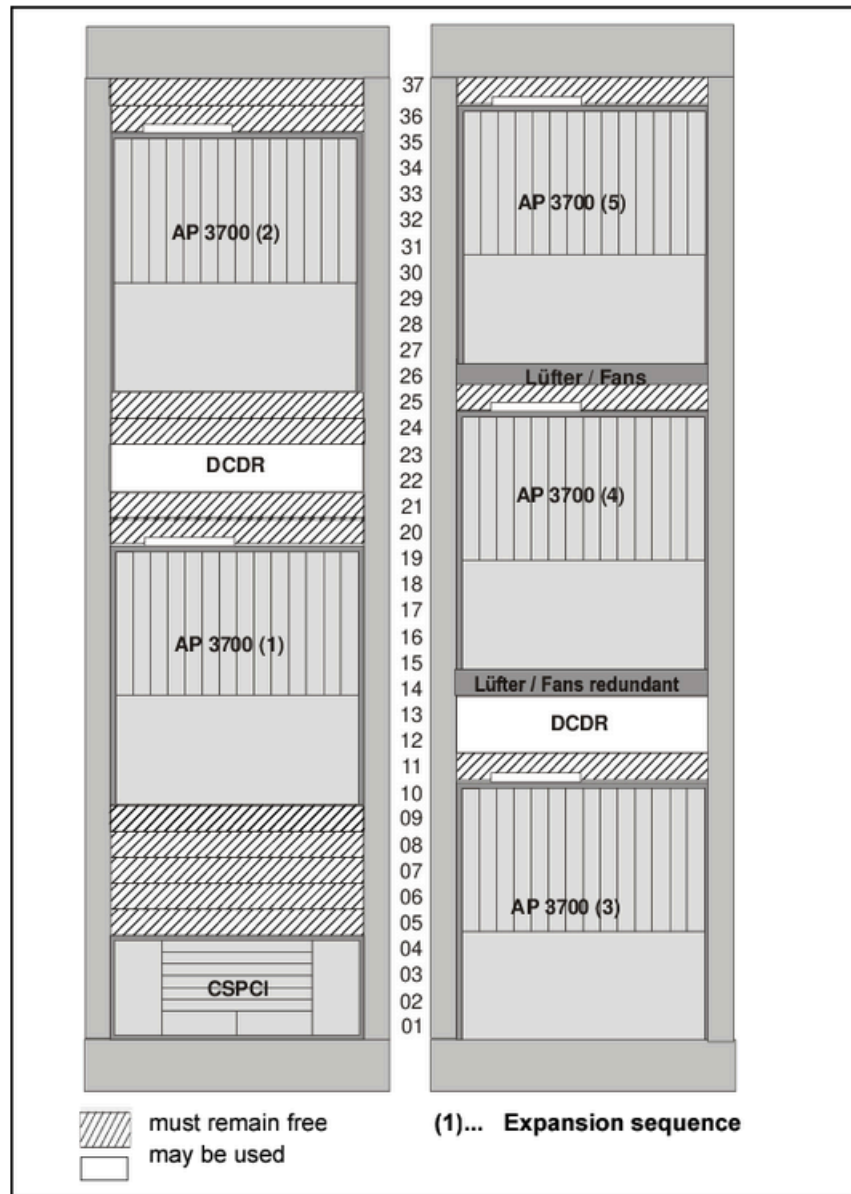


Figure 75: Installing CSPCI with AP 3700 in a cabinet with 37 rack units

5.8.3.4 Sample Configuration CSPCI with AP 3700 in a Cabinet with 42 Rack Units

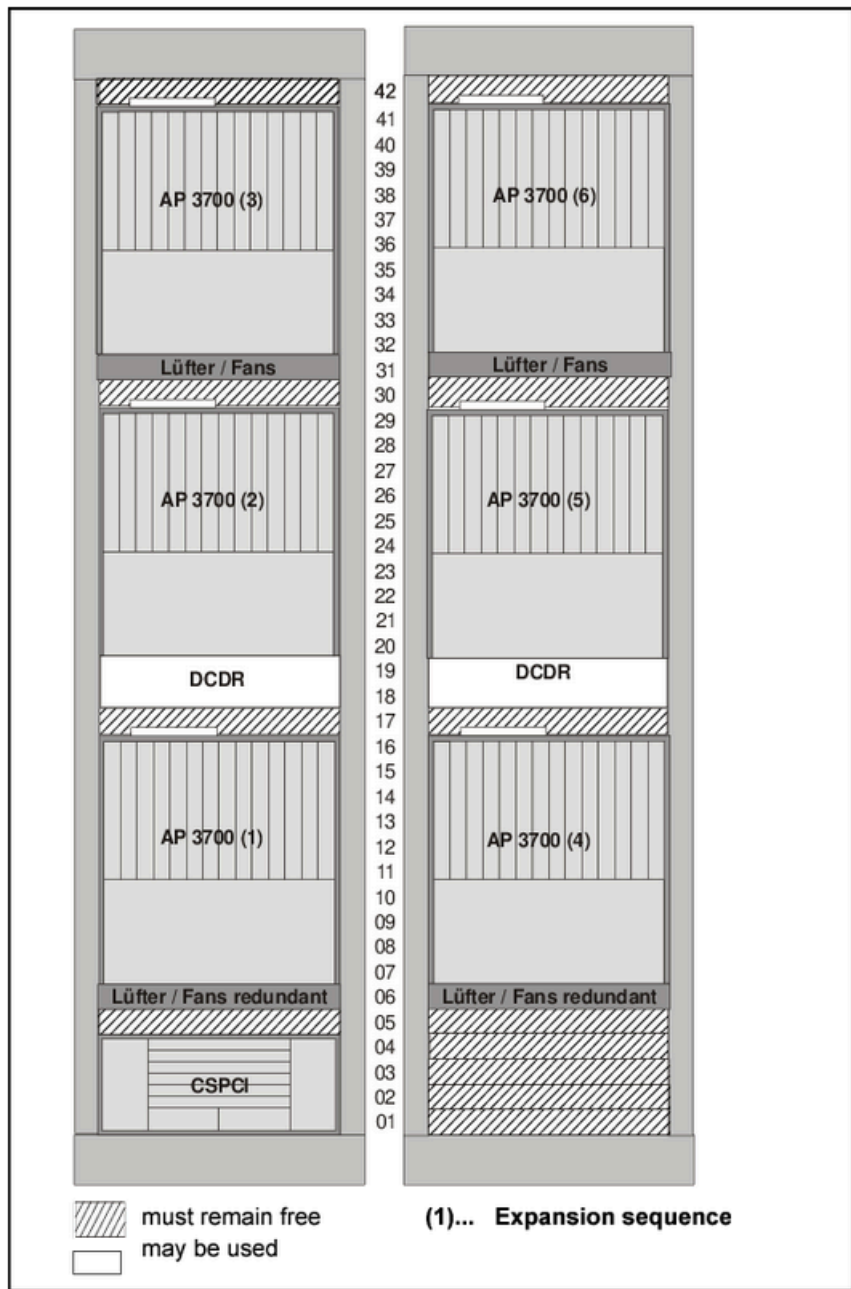


Figure 76: Installing CSPCI with AP 3700 in a cabinet with 42 rack units

5.8.3.5 Sample Configuration CSPCI with AP 3700 in a Cabinet with 47 Rack Units

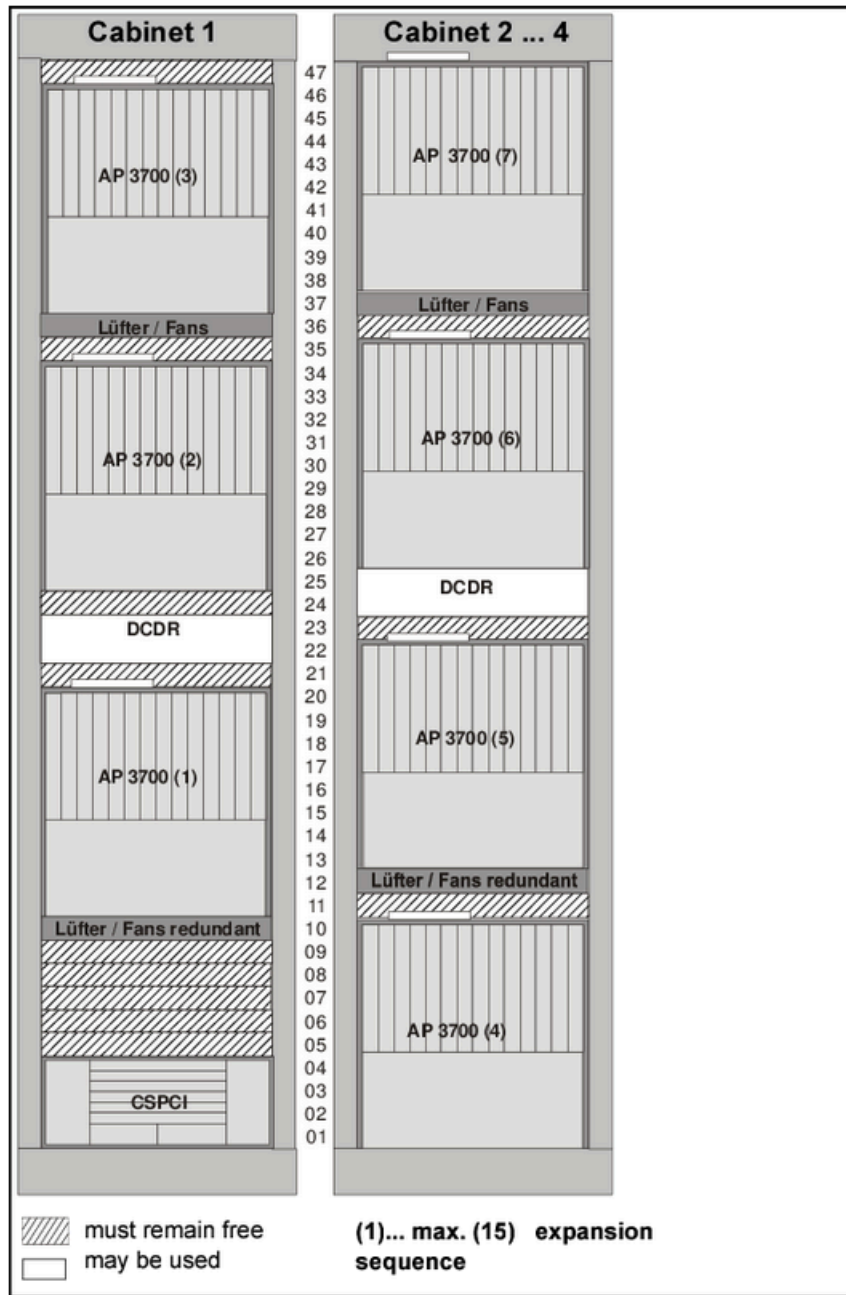


Figure 77: Installing CSPCI with AP 3700 in a cabinet with 47 rack units

5.9 MDFHX 6 Mounting Location, I.M.

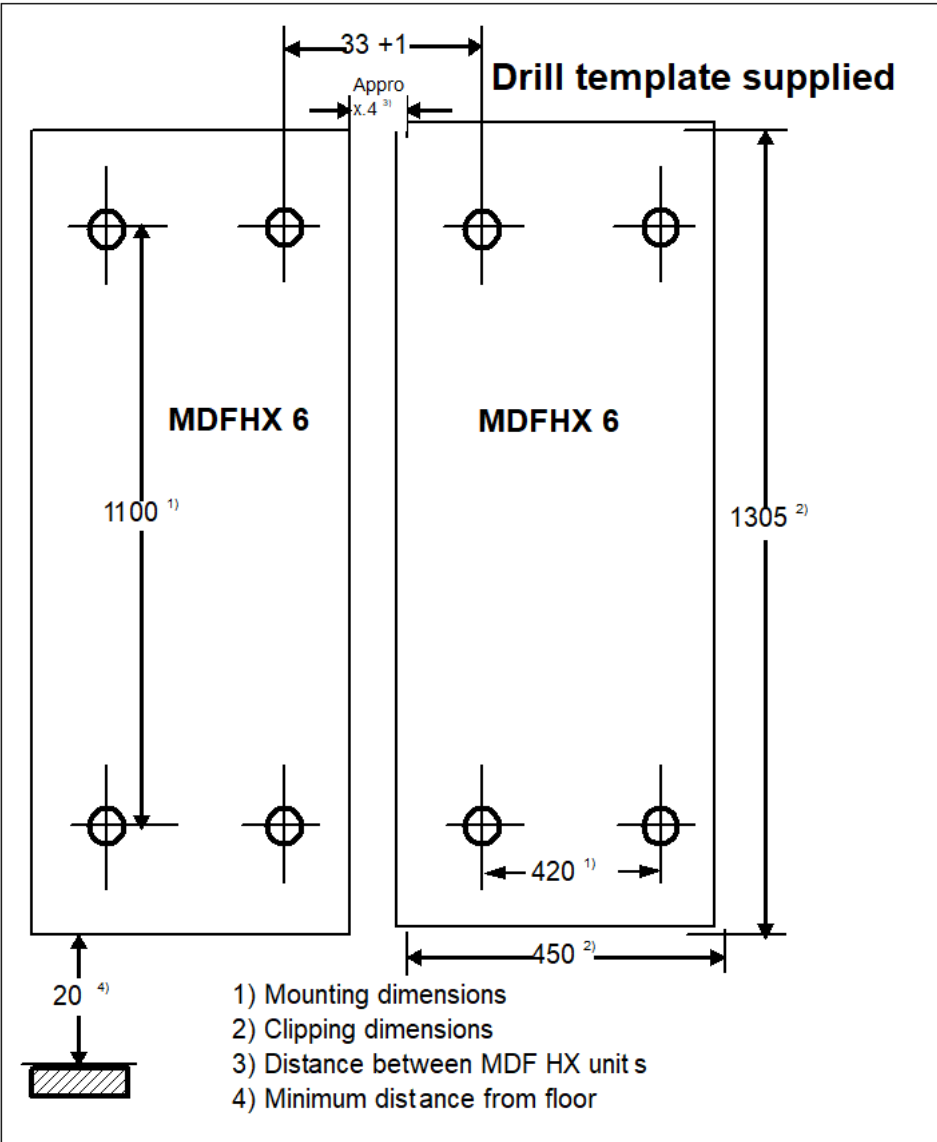


Figure 78: Mounting the MDFHX 6 wall fixture

### 5.10 MDFHX 8 Mounting Location, I.M.

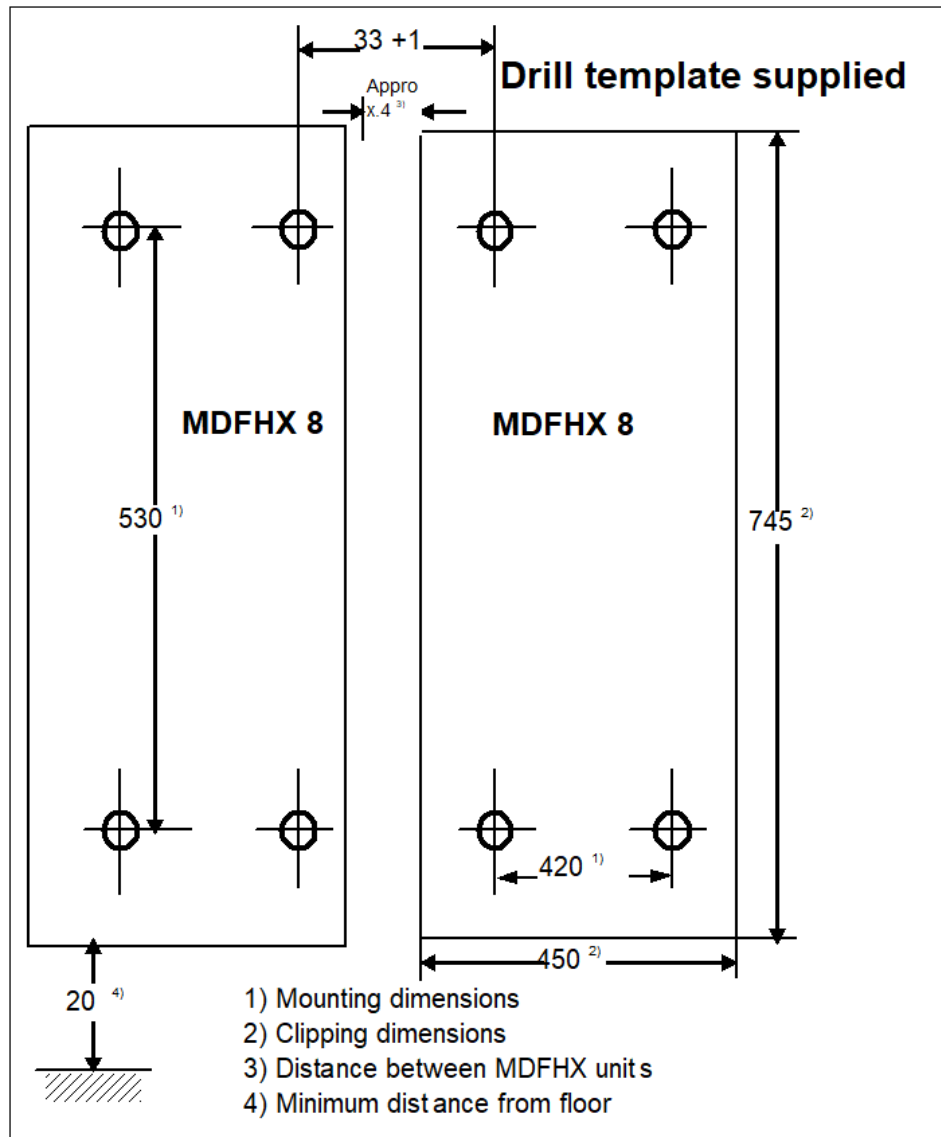


Figure 79: Mounting the MDFHX 8 wall fixture

## 6 Grounding the OpenScape 4000

This section describes instructions for grounding the main distribution frame (MDF) and the system.

---

**IMPORTANT:** Implementation regulations based on IEC 60364 and 60950-1 should be observed during installation. [Chapter 1, "Connection to the Power Supply"](#) should also be observed.

---

Separate protective grounding and equipotential bonding is particularly important within the framework of the safety regulations for OpenScape 4000.

This means it is extremely important for safety that a second ground is installed in addition to the ground wire on the supply according to the instructions in this installation guide. This guarantees the protection of boards from atmospheric overvoltages / lightning strikes even when the mains plug is removed and the overvoltage is coupled via the connected station and trunk lines. This is the only set-up that protects users from electric shocks.

---

**NOTICE:** If this regulation on system grounding is not followed, authorization for operating the system is no longer valid.

---

Thus, proper system grounding is extremely important when conforming to requirements for electromagnetic compatibility.

If the system is not grounded correctly, potential differences in the system when a critical switching threshold of voltage levels is reached can cause faults. Ground loops resulting from differing ground potentials in the ground busbars (fixed ground connection) and in the PE wires on the power supply unit should be prevented by implementing measures in the electro-installation (see [Section 6.5, "System Ground Connections \(19" variant\)"](#)).

Basic principles for installing a ground connection:

- Fixed ground connections are laid from the grounding point in the OpenScape 4000 housing directly to the ground busbar for the building.
- No further ground cables should be connected to the system or its components (MDF, etc.), as otherwise loops may occur.
- Additional components (MDF, etc.) are grounded by connecting the relevant grounding point directly to the grounding point in the OpenScape 4000 housing (=radial grounding). These components are not grounded using separate ground lines provided by the building installation.
- Please ensure that the PE ground wire supplied due to the connection of the 230V/110V power supply network has the same potential as the fixed ground connection. This is guaranteed when both ground wires are branched by the same ground busbar in the building installation and cannot create potential differences en route to the connection to OpenScape 4000.

### 6.1 Grounding the Main Distribution Frame (MDF)

---

**NOTICE:** The main distribution frames must be connected directly to the ground busbar. No ground connection should be

## Grounding the OpenScape 4000

### Connecting and Grounding the Boxes in the 30" Cabinet

established directly between the main distribution frame and the base cabinet.

To ground the main distribution frame:

- 1) Connect the grounding wire (green/yellow) from the ground busbar (building ground) to terminal connection (1) of the main distribution frame (see Figure 1).

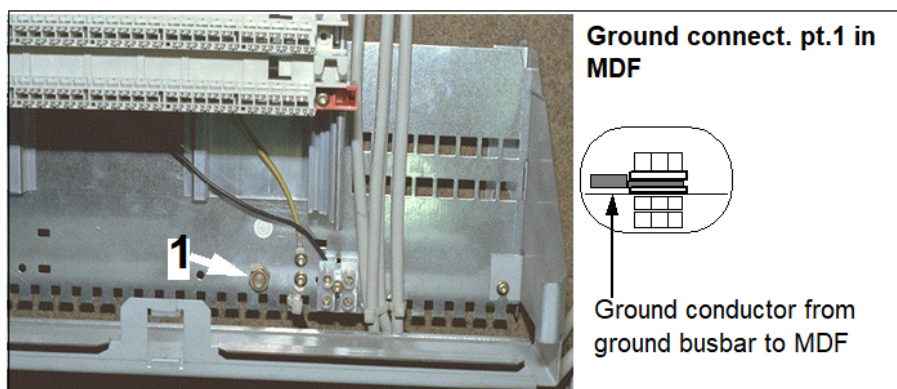


Figure 80: OpenScape 4000 ground connection

- 2) In the case of several main distribution frames, connect a grounding cable directly to each main distribution frame (star-shaped) from the ground busbar to terminal connection (1) of the main distribution frame (see Figure 1).

## 6.2 Connecting and Grounding the Boxes in the 30" Cabinet

Figure shows the placement of the connecting plate assemblies (straps) for grounding purposes.

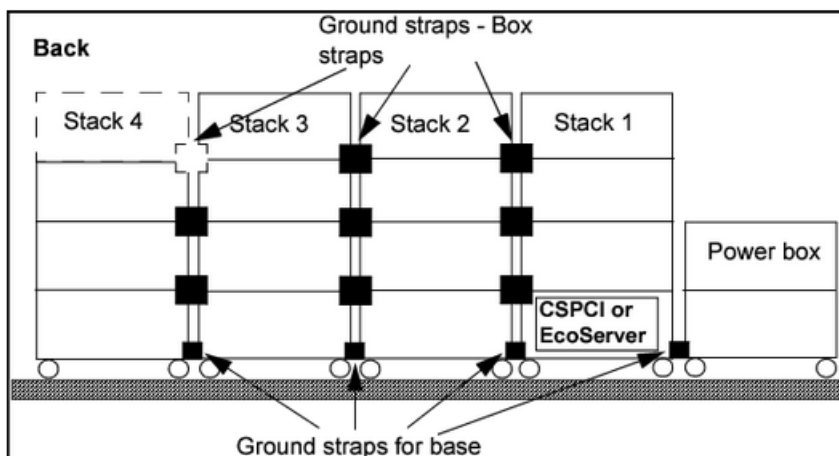


Figure 81: OpenScape 4000 grounding straps (30" cabinets)

**IMPORTANT:** No extra PE line (green/yellow) is needed for the CSPCI box or the EcoServer. An equipotential bonding conductor must simply be connected. Grounding occurs via the AC cable or the 0 V DC supply.

## 6.2.1 Grounding the Base Cabinets

To ground the base cabinets:

- 1) Position the individual stacks and the power box according to the site to avoid repositioning them later.
- 2) Using the supplied ground straps (1), determine the correct distance between the roller bases by inserting the straps in adjacent bases (see [Figure 3](#)).
- 3) Attach the various ground straps to the left (2) and right (3) of the roller base using the screws that are provided.



Figure 82: Installing the ground strap at the base of the cabinets

## 6.2.2 Installing the Ground Straps Between Cabinets



**WARNING:** Risk of electric shock as a result of an incorrect grounding conductor connection. Never operate the system without the specified straps. The strapping serves as an internal grounding conductor connection for the individual components.

To install the ground straps between cabinets:

- 1) Removing the four screws shown in (1) of [Figure 4](#).
- 2) Insert the supplied ground straps (2) and tighten the screws.

**Grounding the OpenScape 4000**  
Grounding the System (30" cabinet)

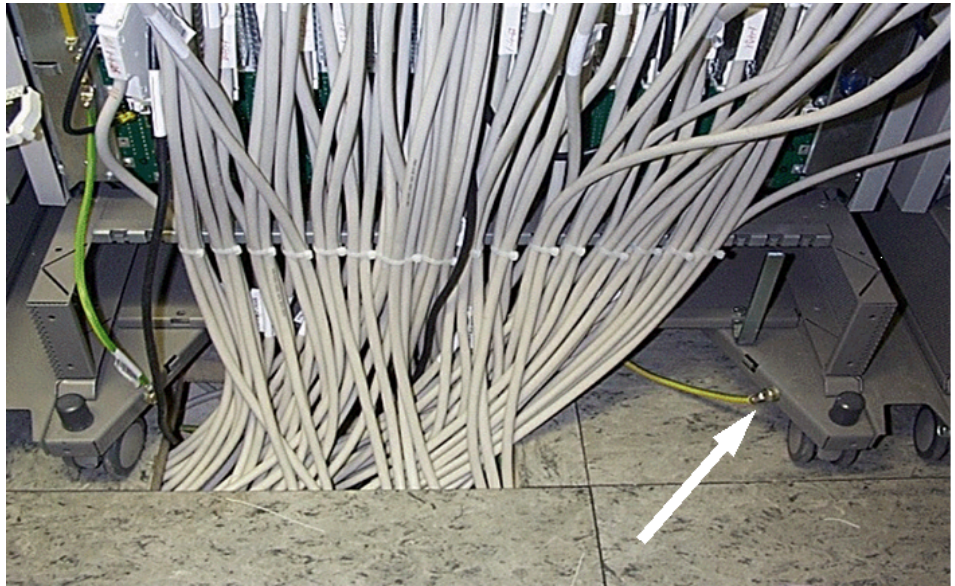
- 3) Depending on the system configuration, attach additional ground straps between the two stacks and the power (3) and (4).



**Figure 83: Installing the ground straps between the cabinets**

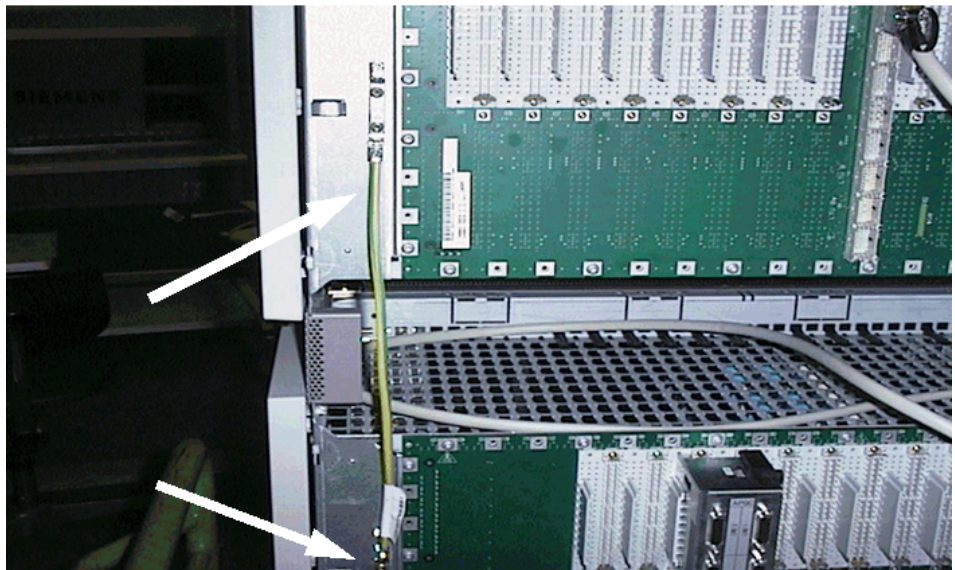
**6.3 Grounding the System (30" cabinet)**

Make sure to ground the system by connecting the grounding cable directly from the ground busbar to the ground connection on the roller base (see [Figure 5](#)).



**Figure 84: OpenScape 4000 grounding straps - 30" cabinet**

An internal ground conductor between the base cabinet and the expansion cabinets is supplied ex-works. See [Figure 6](#).



**Figure 85: OpenScape 4000 internal ground connection (30" cabinet)**

## 6.4 Grounding AP 3700 System Cabinets

To perform protective grounding (hereinafter referred to as "grounding") on the AP 3700 cabinets, see the following alternatives, which depend on the installation (standalone unit or expansion cabinet; see [Figure 7](#) for grounding connectors):

**Grounding the OpenScape 4000**  
System Ground Connections (19" variant)

- Connect the ground conductor directly from the ground busbar to the grounding connector.

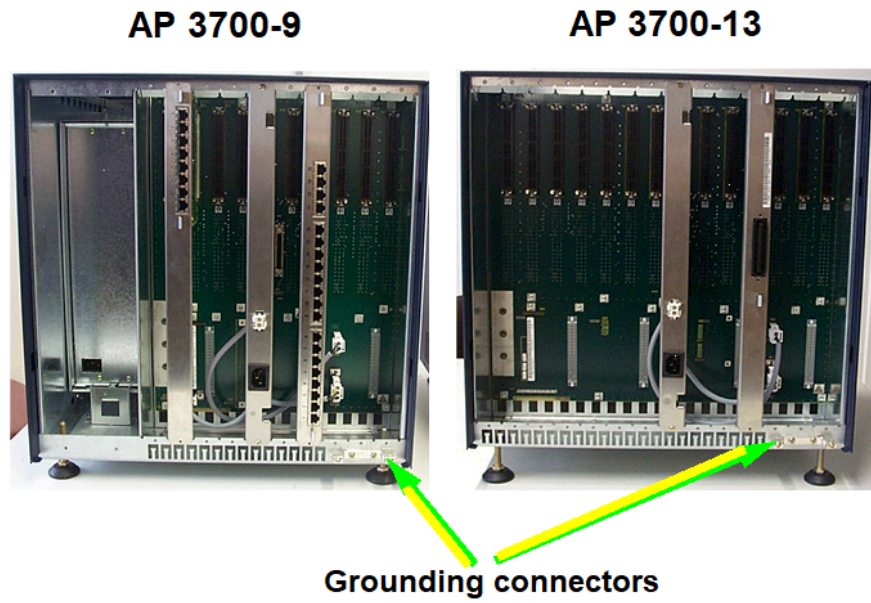


Figure 86: AP 3700-9/AP 3700-13 grounding connectors

**6.5 System Ground Connections (19" variant)**

### 6.5.1 Ground Pattern for 19" AC Connection

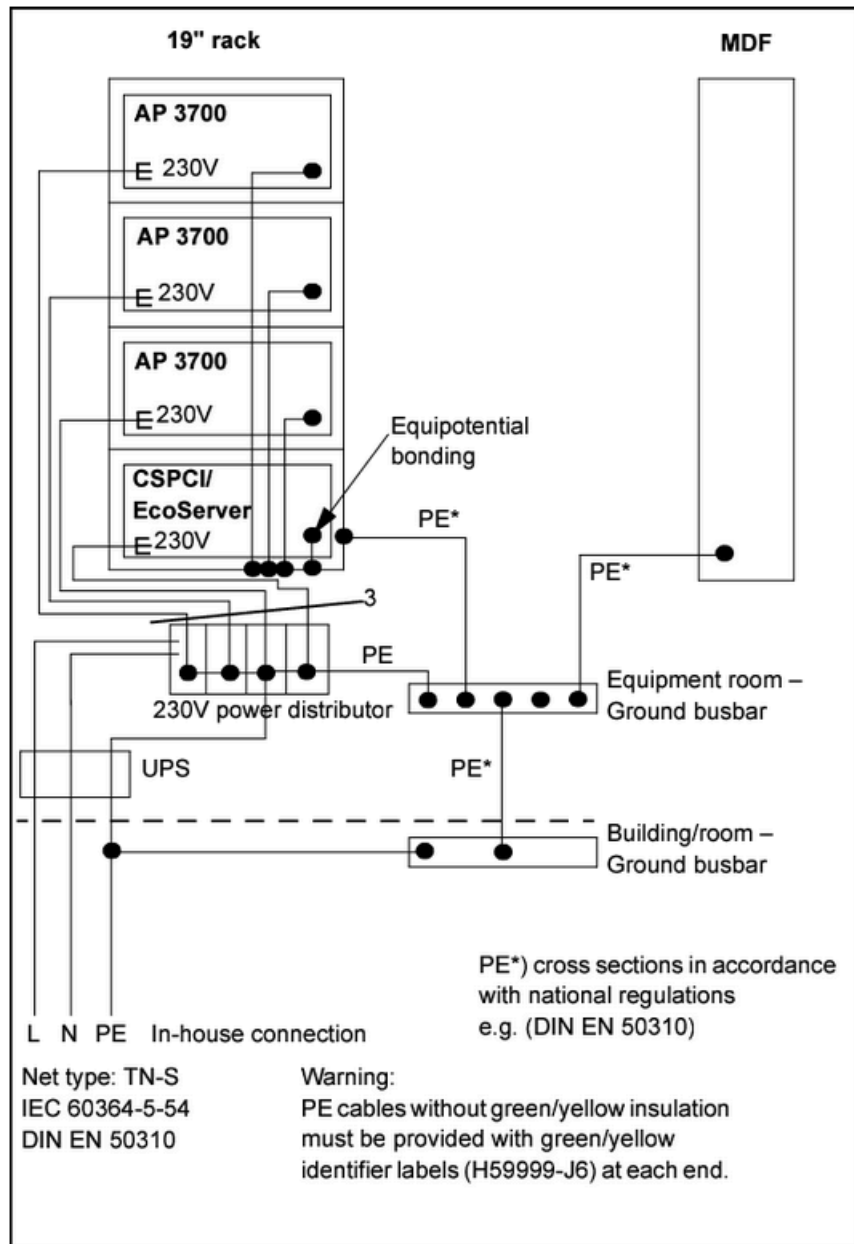


Figure 87: Ground pattern for 19" AC connection

### 6.5.2 Ground Pattern for 19" DC Connection

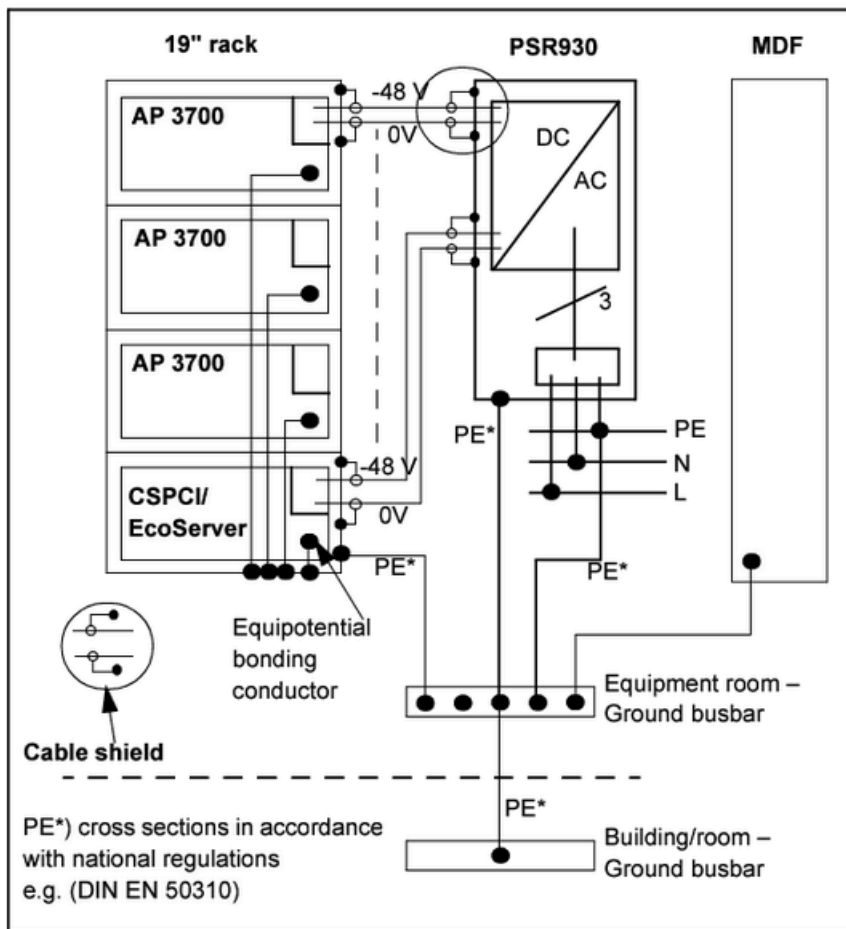


Figure 88: Ground pattern for 19" DC connection

### 6.5.3 Ground Pattern for AC Standalone

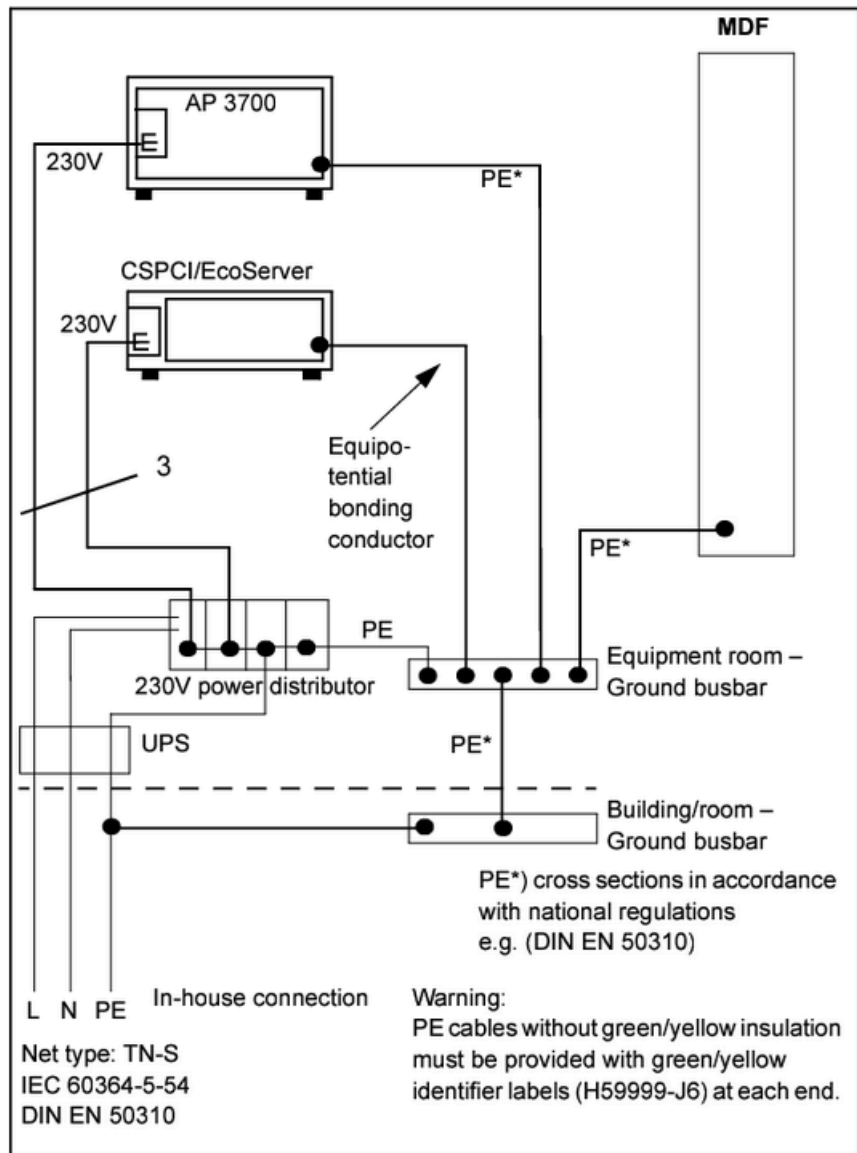


Figure 89: Ground pattern for AC standalone

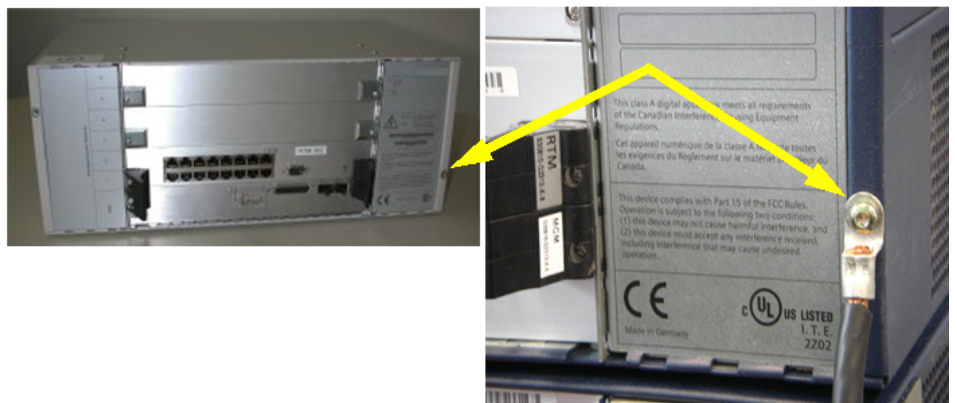


Figure 90: CSPCI backplane - Equipotential bonding conductor



Figure 91: EcoServer - Equipotential bonding conductor

### 6.5.4 Ground Pattern for DC Standalone

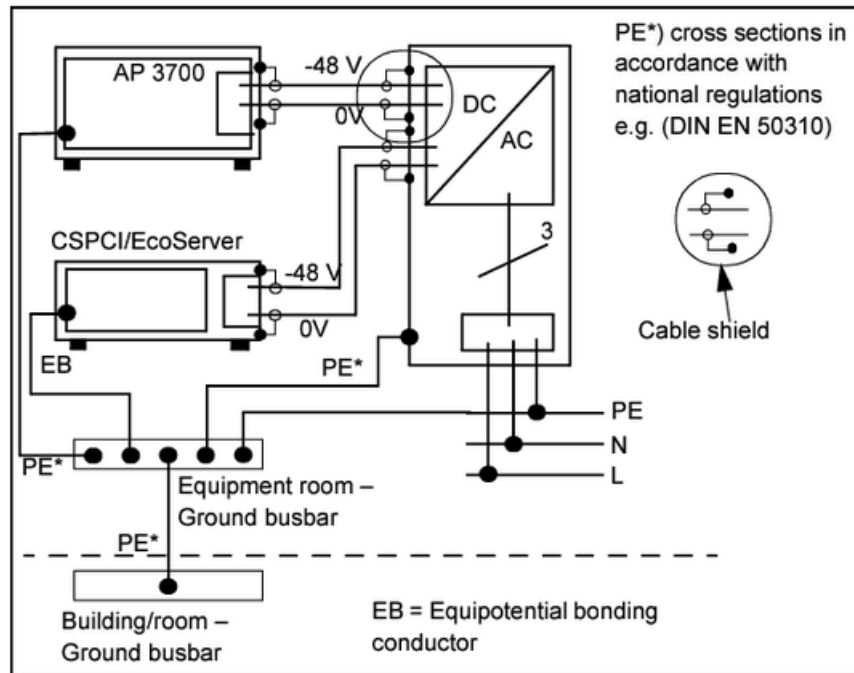


Figure 92: Ground pattern for DC standalone

Figure 14 and Figure 15 show a diagram of the system ground connections with the corresponding ground straps.

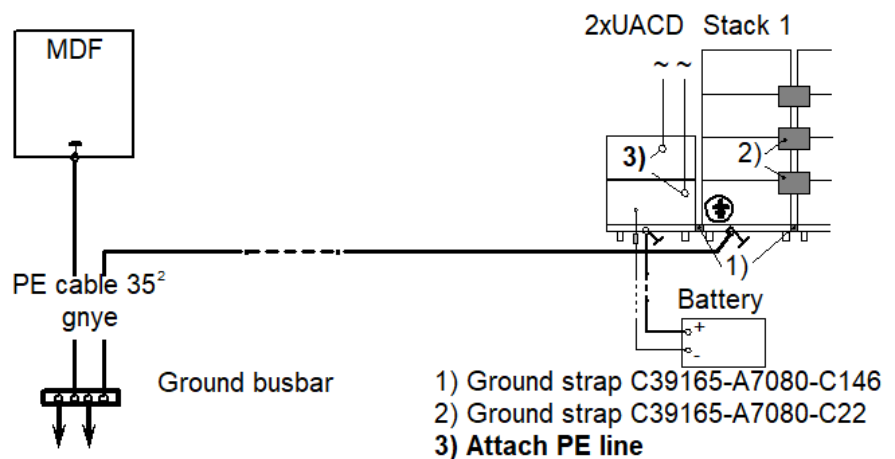


Figure 93: Schematic representation of OpenScape 4000 system ground connections

Figure 15 shows how the ground connector is connected to the 0-V busbar on the 30" cabinet

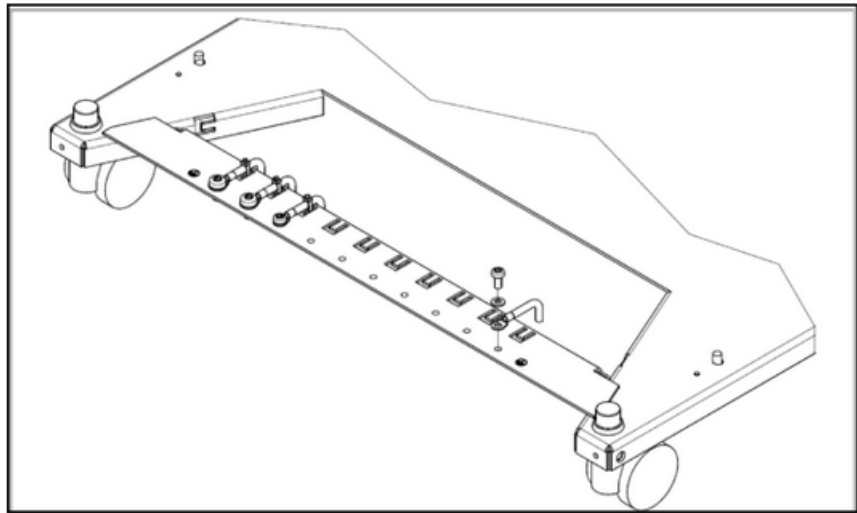


Figure 94: Ground connection from ground busbar to the 0-V busbar on the 30" cabinet

## 7 Connecting to the Mains and Power Supply

This chapter describes the various mains connection and power supply variants.

### 7.1 Connecting to the Mains

---

**NOTICE:** The OpenScope 4000 PSU is sufficiently protected on the mains power side (AC) against lightning strikes of up to 2kV. For areas at particular risk, it is recommended that additional lightning protection be provided before the connection line. The lightning ground bar with the part number C39334-Z7052-C32 offers increased protection up to 4kV. The use of a lightning ground bar is mandatory in Brazil.

---

---

**IMPORTANT:** Mains is a term used in Europe to describe a normal commercial outlet. Mains is going to be used throughout this document to describe the AC outlet.

---

---

**IMPORTANT:** The OpenScope 4000 must be connected to a TN-S network for installation purposes. An independent electric circuit must be used to protect both cabinets in the event of mains failure. TN-S is a type of grounding classification. Each letter indicates as follows: - T-All exposed conductive metalwork connected directly to ground. - N-All exposed conductive metalwork connected directly to the grounded supply conductor - S-Separate and neutral ground conductors.

---



**WARNING:** Electric shock due to disconnected ground wire! The grounding wire of the in-house power connector must always be connected to the mains power socket first.

---

OpenScope 4000 has been designed to accept four different types of power supply worldwide as follows:

- Three-phase mains (~230 V/400 V)
- Single-phase mains for max. 2 power supply units
- Single-phase mains with midpoint grounding (~110 V/220 V) or (~120 V/240 V)
- Three-phase mains (~120 V/208 V) or (~127 V/220 V)

**There are two connection variants to the mains:**

- Connecting to the mains directly by means of a power supply unit (nonredundant power supply) in the individual shelves (LUNA/LPC80). To connect the OpenScope 4000, modem and TAP (technician workstation) to the mains, a multiple-plug connector must be supplied by the customer. This multiple-plug connector must be installed so that the system power cable supplied is sufficient (length = 3 m [10 ft]).



**WARNING:** Safety cannot be guaranteed if the mains plugs are inaccessible. The mains plug must be easily and safely accessible in all installation variants. Unplug the mains plug immediately in the event of danger!

- 
- Connecting to the mains by means of a power box (redundant power supply)



**WARNING:** Electric shock due to disconnected ground wire! Before starting up the system and connecting the stations, connect the system correctly to the ground wire. Never operate the system without the required ground wire.

---

**IMPORTANT:** You can choose which variant is applicable to your installation.

---

### 7.1.1 Connecting to the Mains with LUNA/LPC80 Power Supply Units

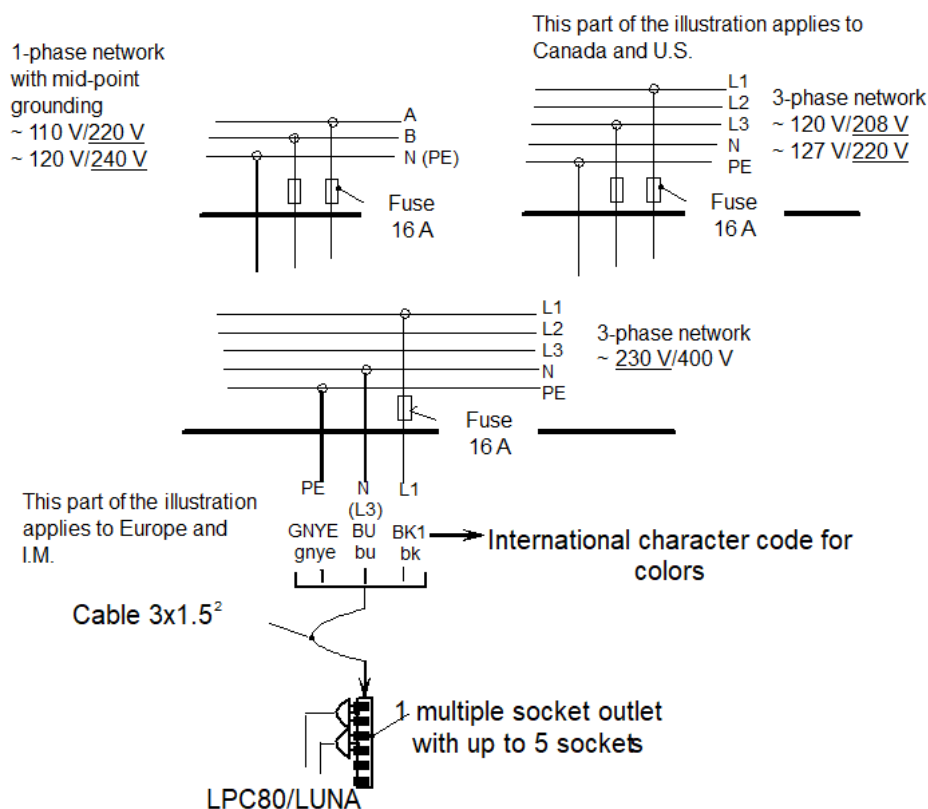
In the nonredundant power supply variant, the mains connection is made directly to the various power supply units by means of a connector strip (the connector strips are located in the base of each stack). Depending on the local power supply (in-house connection), you must observe the connection criteria in [Figure 1](#).

---

**IMPORTANT:** In Canada and U.S., only L1, L2, and PE are brought to the wall socket. The neutral lead for 208 Vac power is not brought to the wall socket.

---

## Connecting to the Mains and Power Supply



**Figure 95: Mains connection LPC80/LUNA**

The power cables should already be installed in new systems. Should the AC-to-DC shelf power supply cables become unplugged during transit, route the power cable in a OpenScope 4000 as follows:

- 1) Ensure that the system is off.
- 2) Plug the power cable into the AC-to-DC shelf power shelf supplies ( LPC80).
- 3) Route the power cable through the metal knock-out (see [Figure](#) ) and to the back of the system.
- 4) Secure the power cable with a tie-wrap on the metal knock-out.

**NOTICE:** Two cable ties are required for proper EMI (electromagnetic interference) grounding.

- 5) Route and plug the other end of the power cable to the mains socket (AC outlet) in the base unit (BAU) under the shelf (see [Figure](#) ).

- 6) Repeat this procedure to the L80XF (expansion) cabinets if you have a multi-cabinet installation.



Figure 96: Routing the power cable

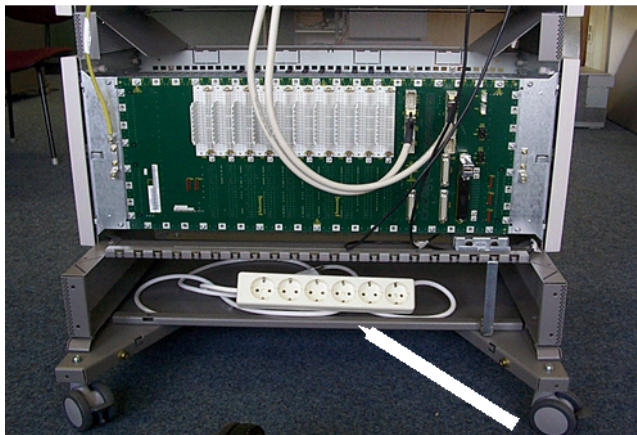


Figure 97: Connecting OpenScape 4000 to the mains, I.M.

---

**IMPORTANT:** Figure shows an illustration for the I.M. Canada and U.S. use a different outlet strip.

---

### 7.1.2 Connecting to the Mains Using the Power Box

---

**IMPORTANT:** In North America, connection is made to the mains using a power cable with a plug. This power cable is connected to the mains socket at the factory. The mains socket is mounted in the UACD and the strain-relieved connection cable is fed out of the power box.

---

In the case of the redundant power supply variant, the connection is made to the mains using a power connector socket on the power box. Depending on the local power supply, you may need to make a distinction between the different connection variants.

To connect to the mains by means of the power box:

- 1) Remove the shielded power line with connection box from the power box (Powershell 1 or Powershell 2) and remove the cover of the mains socket.
- 2) Plug the power cord to the mains socket.

## Connecting to the Mains and Power Supply

### Installing a Three-Phase Network

---

**IMPORTANT:** The shielded power lines of the powershelves no longer need to be attached to the frame using a grounding bracket.

---

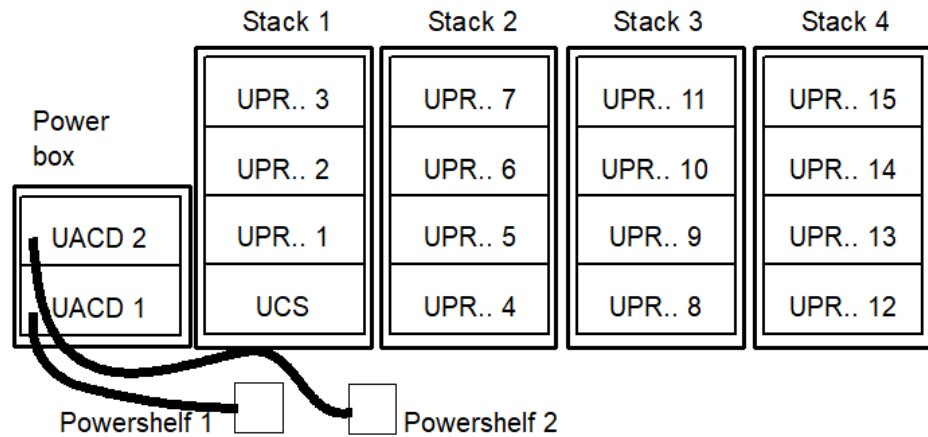


Figure 98: Connecting to the mains using the power box

## 7.2 Installing a Three-Phase Network

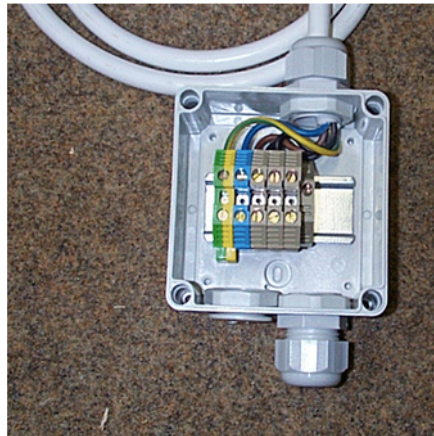


**WARNING:** Electric shock due to disconnected ground wire! Before you connect the three-phase power cable (~230 V/400 V), ensure that the protective ground terminal (building ground) is connected to the system frame.

To install a three-phase connection:

- 1) Remove the cover to the junction box.
- 2) Unscrew the coupling on the junction box.
- 3) Insert the open end of the power cable through the junction box.
- 4) Strip the wires on the power cable, insert, and secure the wires to the terminals as follows: (see [Figure](#) and [Figure](#)):
  - a) Attach the green/yellow wire to the (GNYE) terminal.
  - b) Attach the blue wire to the (BU) terminal.
  - c) Attach the brown wire to the (BN) terminal.
  - d) Attach each of the two black wires that emerge from the mains cable to a separate (BK) terminal on the distribution socket.
  - e) Depending on the system configuration, repeat the same procedure sequence for the second power socket.

- 5) Tighten the screw on the junction box and replace the cover.



The colored wires are as follows.

Green/yellow = grounding wire PE (GNYE)

Blue = neutral N (BU)

Brown = phase 1 L1 (BN)

Black = phase 2 L2 (BK)

Black = phase 3 L3 (BK)

Figure 99: UACD junction box

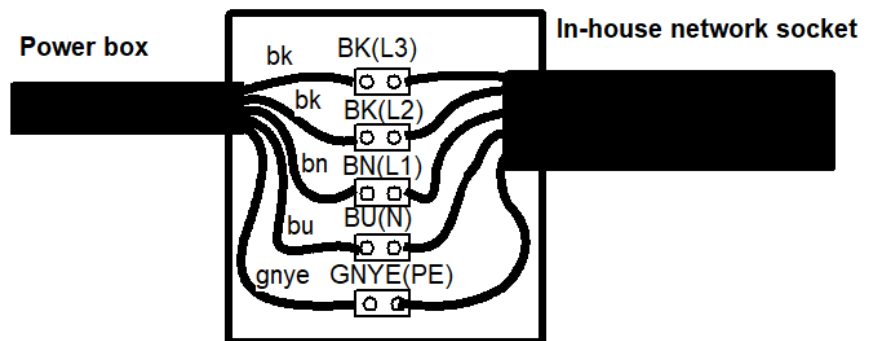


Figure 100: Wiring the UACD junction box

## 7.3 Installing a Single-Phase Network

With this type of connection, you need to make a few wiring changes in the junction box and UACD power supply frame before you can make the connection to the in-house network.



**WARNING:** Electric shock due to disconnected ground wire! Before you connect the single-phase power, ensure that the protective ground terminal (building ground) is connected to the system frame.

To install a single-phase connection to a maximum UACD configuration:

- 1) Remove the cover to the junction box.
- 2) Unscrew the coupling on the junction box.
- 3) Insert the open end of the power cable through the junction box.
- 4) Strip the wires on the power cable, insert, and secure the wires to the terminals as follows:
  - a) In the junction box, bridge the BN(L1) port with BK1(L2).
  - b) Connect the power switches 1, 2 and 3 to the ACDPX in the power supply frame of the UACD, as shown in the Figure [Figure 101: Three-phase/single-phase connection for two power supply units](#) on page 108

## Connecting to the Mains and Power Supply

### Overview of Mains Connection 1

- 5) Replace the cover of the junction box.
- 6) Route the power cable to the mains.

## 7.4 Overview of Mains Connection 1

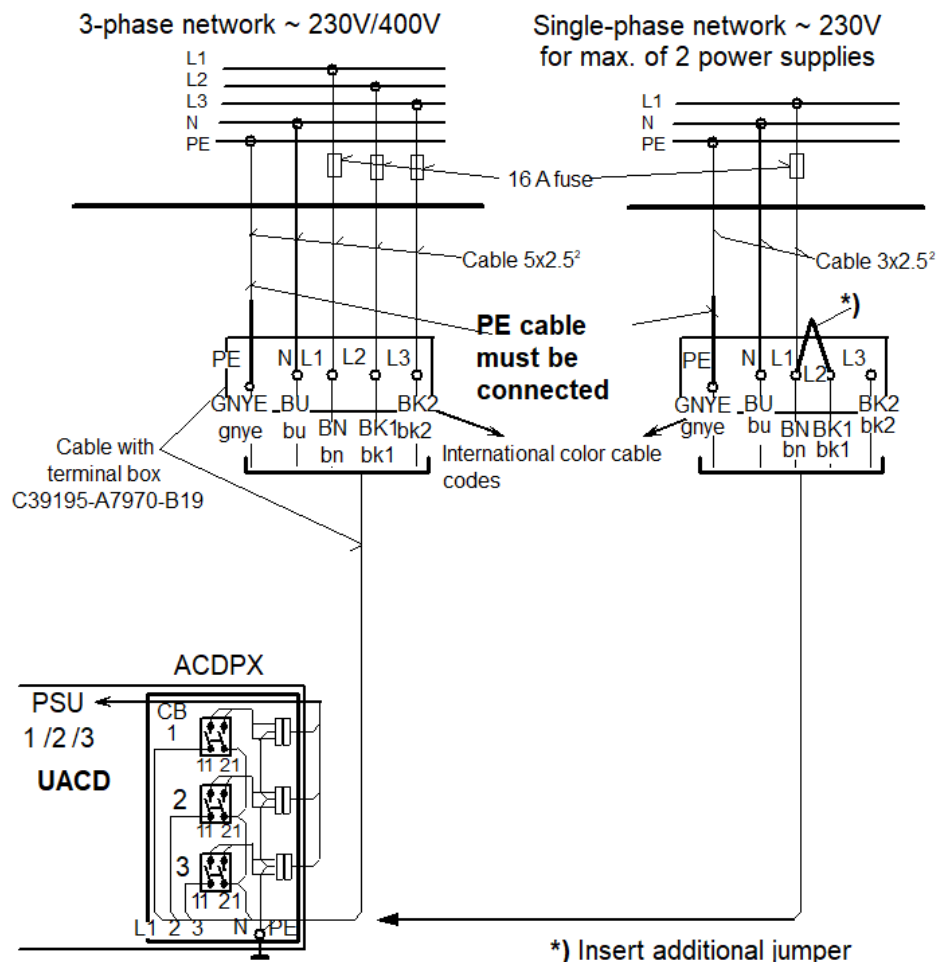


Figure 101: Three-phase/single-phase connection for two power supply units

## 7.5 Installing a Three-Phase or Single-Phase Connection with Mid-Point Grounding, I.M.

With this type of connection, you need to make a few wiring changes in the junction box and also in the power supply frame before you can make the connection to the in-house network.



**WARNING:** Electric shock due to disconnected ground wire! Before you connect the power phases, make sure that the protective ground terminal (building ground) is connected to the system frame.

To install a three-phase or single-phase connection with mid-point grounding:

- 1) Remove the cover to the junction box.
- 2) Unscrew the coupling on the junction box.
- 3) Insert the open end of the power cable through the junction box.
- 4) Strip the wires on the power cable, insert, and secure the wires to the terminals as follows:
- 5)
  - a) Insert and secure the blue (BU) and brown (BN) wires together in the junction box.
  - b) Insert and secure both black (BK) lines together.
  - c) Connect the power switches 1, 2 and 3 to the ACDPX in the power supply frame UACD, as shown in the [Figure 8](#).
- 6) Replace the cover of the junction box.
- 7) Route the power cable to the mains.



**WARNING:** Electric shock due to the connection of unapproved systems! Only one OpenScape 4000 DC system with a 25A fuse may be connected per stack to the UACD.

---



The DC power supply usually has a voltage of 48 V. However, some modules require 60 V. A power supply module (APPS) is used in this case. This -60-V power supply is only provided for individual shelves.

---

**NOTICE:** Never plug in or unplug the APPS module when the power is on.

---

## 7.8 AC Connection to Power Supplies

In systems with nonredundant power supply, the CSPCI shelf contains an ACPCI power supply unit (2 ACPCIs in duplex mode) and each expansion cabinet (L80XF) contains an LPC80 power supply unit. Each of these power supply units is separately fed with ~230V. This power supply unit has an input voltage range of ~176 V to ~253 V (45 Hz - 66 Hz) without supplementary settings. A 48V output voltage is generated and this in turn is transformed into several lower voltages by a second power supply unit. (PSUP).

### 7.8.1 Routing the Power Cables on an AC-Powered, Nonredundant OpenScape 4000

To route the power cables in an ac-powered, nonredundant OpenScape 4000 (see also [Figure](#) and [Figure](#)):

- 1) Ensure that the system is off.
- 2) If your system features redundant CPUs: Connect the power cables to the AC/AC power management unit (LPC80).
- 3) Route the power cables (1) downwards through the frame's metal knock-out (2) (see [Figure](#)) to the base unit assembly (BUA) below the CSPCI/ EcoServer shelf.
- 4) Secure the power cables with tie-wraps on the metal knock-outs (3).
- 5) Plug the other end of the power cables to the ac outlet in the BUA.
- 6) Follow steps 2 through 9 on page 7-157 in Chapter 7, "Routing the Power Cables on an AC-Powered, Redundant OpenScape 4000".

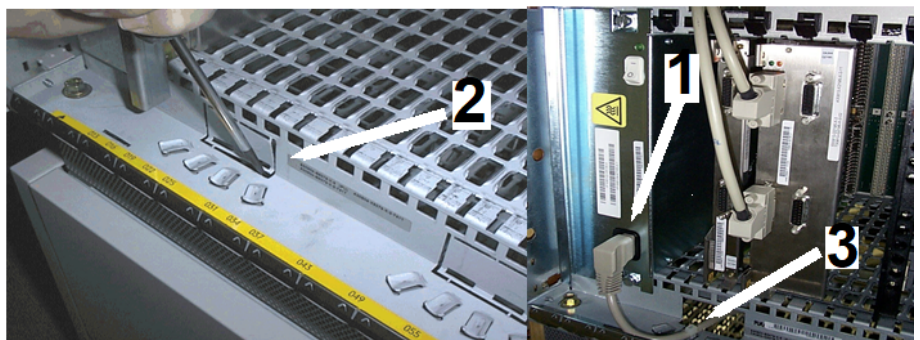


Figure 103: OpenScape 4000 AC installation

### 7.8.2 Attaching the Power Cable to the CSPCI Box

If the power cable has not already been attached at the factory, proceed as follows:

- 1) Remove the fixing screws (1) from the MCM board on the back of the CSPCI box and remove the board (see also [Figure](#) ).
- 2) Insert the power cable in the socket (2) on the CSPCI box and secure it to the cord grip (3) with a cable tie.
- 3) Route the power cable through the cable duct (4) on the MCM board and screw the MCM board back onto the CSPCI shelf.

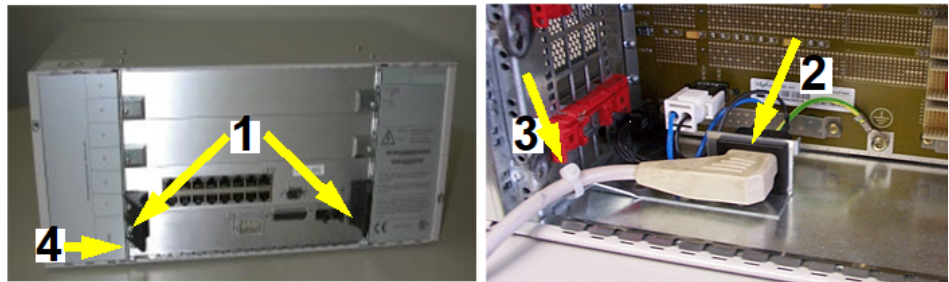
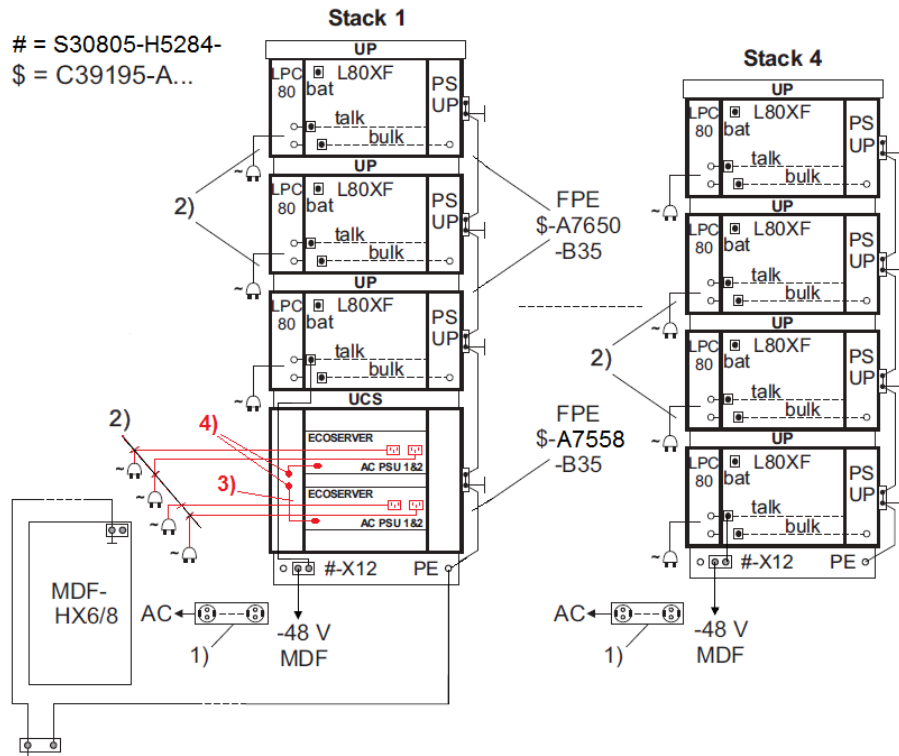


Figure 104: Attaching the power cable to the CSPCI box

**NOTICE:** A ferrite core must be attached to the relevant AC mains cable in order to prevent the system being impacted by external atmospheric interferences, such as radiation (see [Section 4.7, "Attaching the Ferrite"](#)).

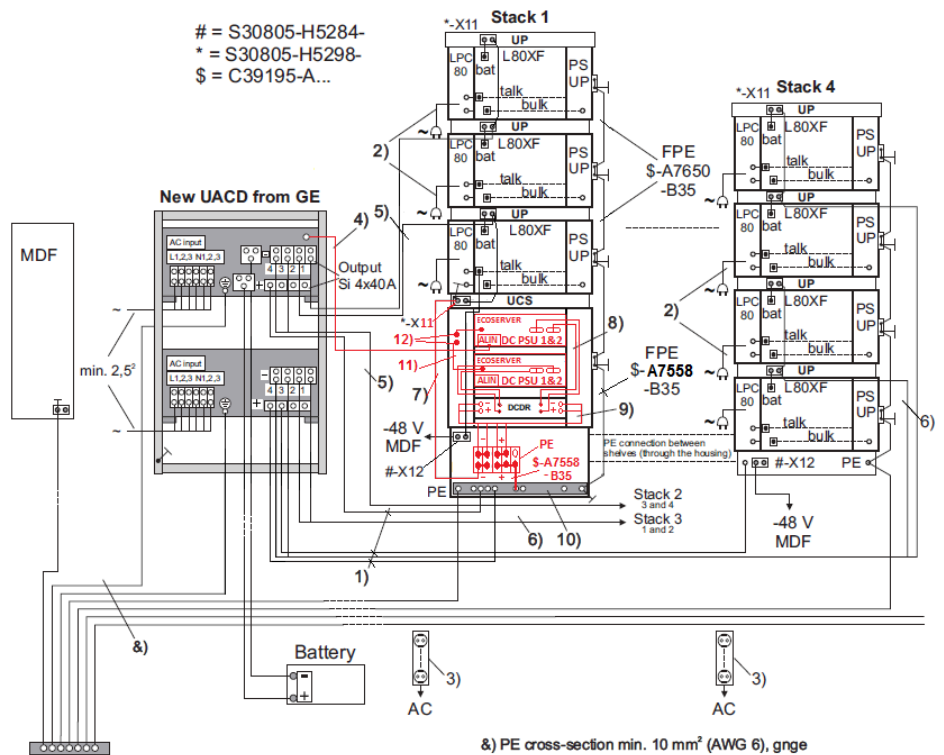
Figure shows a diagram of the AC connection with an L80XF cabinet.



Nr. Sachnummer / No code no.	Bez. / design	Bemerkung / remark von / from --> nach / to
1) C39334- Z7052-C22  S30807- H6586-X	Steckd.-schiene f. "IM"  NAPSK f. "NA"	für / for Stack 1...4
2) C39195- Z7001-C55  C39195- Z7001-C14	power cable for "IM"  " for "NA"	From LPC80 AC, EcoServer --> to Netz od. USV  From LPC80 AC, EcoServer --> to AC power or UPS
3) C39195- A7514-B80	Cable 80cm	Cable for EcoServer equipotential bonding
4) H60118-B4012- Z1	Screw	Screw for EcoServer equipotential bonding cable fixation

Figure 105: AC connection with UP/L80XF cabinet (nonredundant)

### 7.8.3 AC connection with UP/L80XF cabinet + battery backup (non-redundant)



## Connecting to the Mains and Power Supply

Nr. Sachnummer / No code no.	Bezeichnung / design	Bemerkung / remark von / from --> nach / to
1) C39195- A7556-B540	+ Leitung	From UACD --> to 0V-Schiene
2) C39195- Z7001-C55 C39195- Z7001-C14	Netz-Leitung f. "IM" AC pow.-cable f. "NA"	From LPC80 AC --> to Netz od. USV From " --> to AC power or UPS
3) C39334- Z7052-C22 S30807- H6586-X	Steckd.-schiene f. "IM" NAPSK f. "NA"	fur/ for Stack 1...4
4) S30122-X8011- X12	ALIN-cabo 5m	From UACD Basiscontroll. --> to EcoServer ALIN, DB9 connector.
5) C39195- A7944-B16	- Leitung	From UACD --> to Stack 1 ... 2
6) C39195- A7944-B17	- Leitung	From UACD --> to Stack 3 ... 4
7) C39195- A7954-B33	DC-CONNECT. CABLE	From UCS --> to DC terminal block (remove the clear tap)
8) C39195- A7944-B56	Leitung +/- 48V	From DCDR --> to EcoServer DC PSU
9) C39195-Z70- C91	CABLE 16MM2 BLACK	From DCDR --> to DC terminal block connection
10) C39165- A7080-D1	0V-Schiene	wird im Stack 1 an die Rollenplatte montiert
11) C39195- A7514-B80	Cable 80cm	Cable for EcoServer equipotential bonding
12) H60118-B4012- Z1	Screw	Screw for EcoServer equipotential bonding cable fixation

**Figure 106: AC connection with UP/L80XF cabinet + battery backup (nonredundant)**

### 7.8.4 Connecting the Mains Cable to the EcoServer

If the mains cable has not already been attached to the system at the factory, connect it to the power supply (1) on the rear of the EcoServer and run it downwards at the back of the system to the designated mains socket rail (only for cabling within a 19"/30" rack).



Figure 107: AC power supply for EcoServer

---

**NOTICE:** In case of redundancy, connect a second mains cable to the power supply (2) and likewise run it downwards to the designated mains socket rail.

---

Connect the mains cables individually to the designated mains sockets in case of a standalone connection.

## 7.9 Setting the Operating Mode for the LPC80, I.M.

Two power supply units (PSU) from two different manufacturers can be used for LPC80. A switch located at the back of the PSU allows you to set the operating mode of the PSU to Power Supply or Battery Charger, depending on the particular application. The operating modes are:

ON	=	Battery charger
OFF	=	Power Supply

---

**IMPORTANT:** The battery charger feature is not used in Canada or U.S.

---

Figure 14 shows the switch of the two different power supply units. Set the operating mode of the power supply unit using this switch.

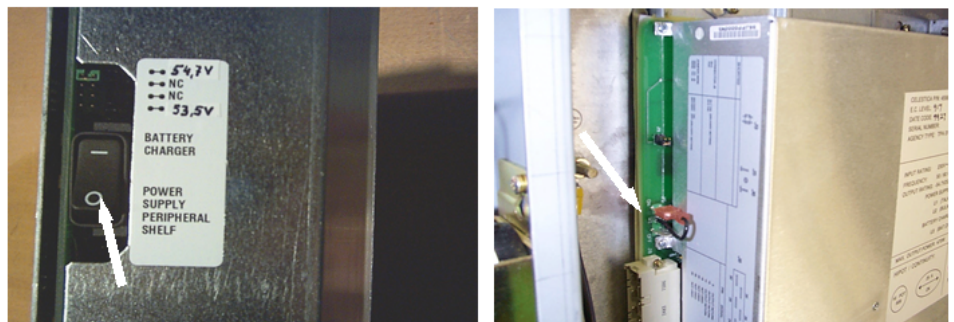


Figure 108: LPC80 settings

### 7.9.1 Setting the Operating Mode

Table 1 lists the operating modes of the LPC80.

**Connecting to the Mains and Power Supply**  
 DC Connection with the External Power Supply, I.M.

Between standard/charger mode (on the back of the LPC80)	for -K7162-	Artesyn: neutral switch, clearly identifiable from sticker  1st option: Battery Charger  2nd option: Power Supply Peripheral Shelf: standard mode forebodes
	for -K7163-	Celestica: jumper W1, clearly identifiable from sticker  ON --> connector W1 with J5 --> battery charger mode  OFF --> connector W1 with J6 --> standard mode for CAB80DSC
	for K7554-	Supplier: MagneTek 3-pin connector behind a window on the underside of the power supply unit. (2 screws)  1. Connector in "Mode1": as used with peripheral shelves  2. Connector in "Mode2": as used with battery chargers
Between two possible voltages (in charger mode)	for -K7162-	Artesyn: jumper setting, clearly identifiable from sticker  1st option: 54.7 V (factory setting)  2nd option: 53.5 V
	for -K7163-	Celestica: jumper J9, clearly identifiable from sticker  1st option: connection between pin 3 and pin 4 from J9 --> 54.7V (factory setting)  2nd option: connection between pin 3 and pin 4 from J9 --> 53.5V
	for K7554-	Supplier: MagneTek Switch on the underside of the power supply unit; (voltages shown on circuit board)  - Switch in left position --> 53.5V  - Switch in right position --> 54.7V

**7.10 DC Connection with the External Power Supply, I.M.**

---

**IMPORTANT:** In Canada and U.S., the UPS provides AC power only. It is not a source of DC power.

---

An external system power supply (uninterruptible power supply [UPS] in the U.S.) is a PSU in which a jumper is connected to the system instead of the LPC80 power supply unit (see [Figure 19](#)). The jumper feeds the “48 V external

power supply to the system. The external “48V is connected from the DC power box to the individual backplanes of the system cabinets.

The connection of an external battery is identical to the connection of an external power supply unit.

### 7.10.1 Routing the Power Cables on an AC-Powered, Redundant OpenScape 4000

The bulk and talk circuit breaker cables connect to the UACD or UDCD at one end. At the OpenScape 4000, you need to connect the bulk and talk circuit breaker cables as follows (see [Figure 22](#)):

- 1) Ensure that the system is off.
- 2) At the back of the CSPCI frame: Connect the BULK circuit breaker cable to the DC connector on the CSPCI box (see [Figure 16](#)) and then create a daisy-chain connection to the X12 connectors on the expansion cabinets.

---

**NOTICE:** Ensure that the cables are locked down, otherwise, the LTU shelf that is connected to is not going to function properly.

---

---

**IMPORTANT:** The top blue connector bulk cable on top of the CSPCI box connects to the bottom blue connector of the LTUW cabinet. The top blue connector bulk cable on the LTUW cabinet connects to the bottom blue connector of the LTUW cabinet immediately above it and so on.

---

- 3) At every cabinet: Connect and tie-wrap the shielded portion of the 48 Vdc bulk input power cables to the cabinet frame.
- 4) At every cabinet: Connect the -48-Vdc bulk input power cable to the shielded ground at the left side of each cabinet.
- 5) For systems with redundant power supply: Route the other two 48 Vdc bulk cables over to the left side of the CSPCI frame and tie-wrap the shielded portion of the cable to the shielded ground.
- 6) Connect the -48-Vdc input talk circuit breaker cables to the X11 connector of the LTUW shelf.
- 7) Daisy-chain the -48-Vdc input talk circuit breaker cables to the upper LTUW shelves.
- 8) At every cabinet: Connect the -48-Vdc talk input power cable to the shielded ground at the left side of each cabinet.
- 9) At the back of the CSPCI frame: Route the bottom blue connector -48-Vdc bulk cable (input) to the -48-Vdc connector at the back of the output distribution panel of the UACD or UDCD. In the UACD, this cable is called

## Connecting to the Mains and Power Supply

the ALUM cable, and it plugs to the TBD connector. In the UDCD, this cable is called the power fail cable, and it plugs to the DCPFX1-E3 connector.

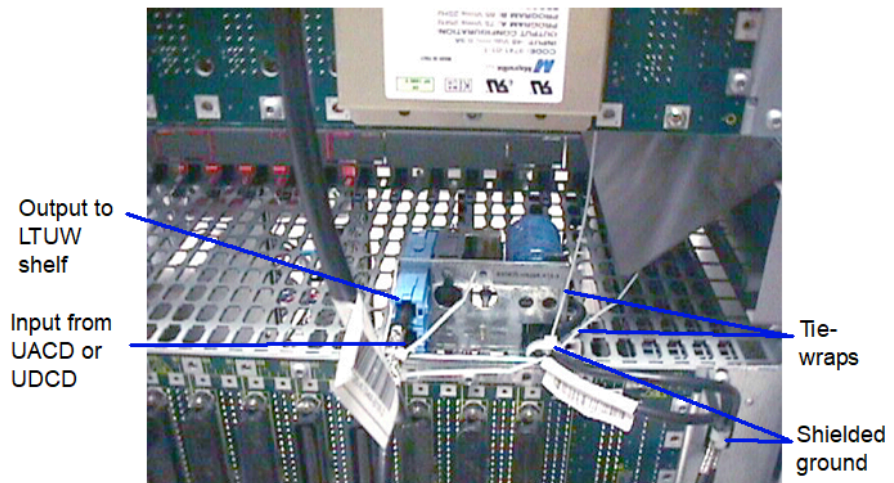


Figure 109: Connecting the bulk power

### 7.10.2 Routing the Power Cables from the UACD and UDCD to the OpenScape 4000

---

**NOTICE:** Ensure that the power is off.

---

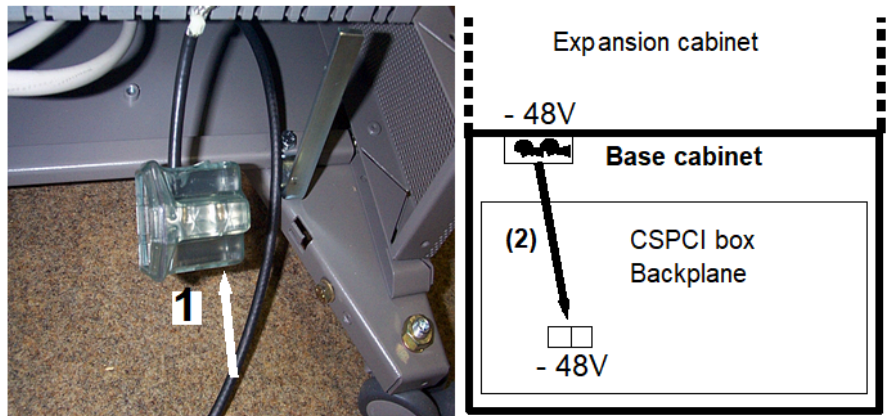
All internal cabling for the UACD and UDCD should be complete when the equipment goes out of the factory. The output power cables on the UACD and UDCD are also already connected on the power shelves.

In the UACD or UDCD, the output power cable must be connected to the CSPCI connector (bottom blue connector of the bulk circuit breaker, see [Figure 15](#)).

### 7.10.3 Attaching a DC Cable to the CSPCI Box

If the DC cable has not already been attached at the factory, proceed as follows:

- 1) Connect the -48V cable from the external battery to the DC terminal (1) on the base cabinet (see [Figure 16](#)).



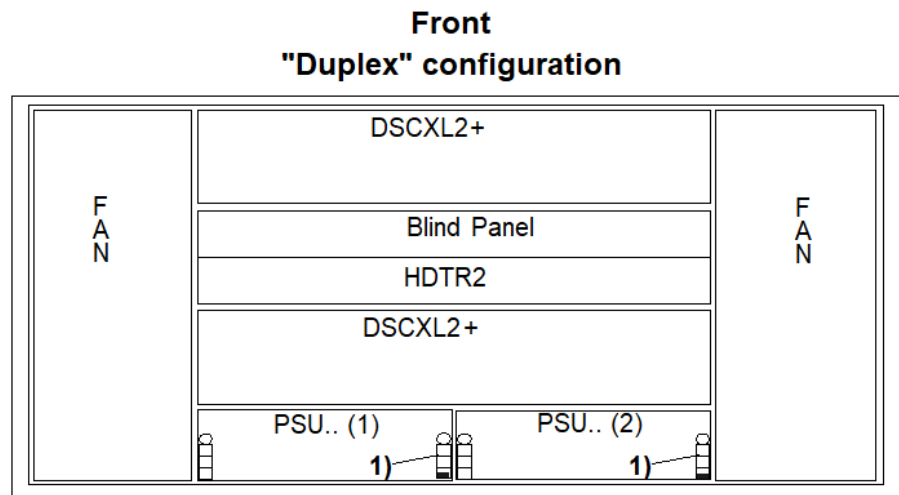
**Figure 110: Connecting the external “48V to the DC terminal on the base cabinet**

- 2) Route the -48V from the -48V fuse module to the CSPCI backplane (2).
- 3) Remove the fixing screws from the MCM board (3) on the back of the CSPCI box and remove the board (see [Figure 18](#)).

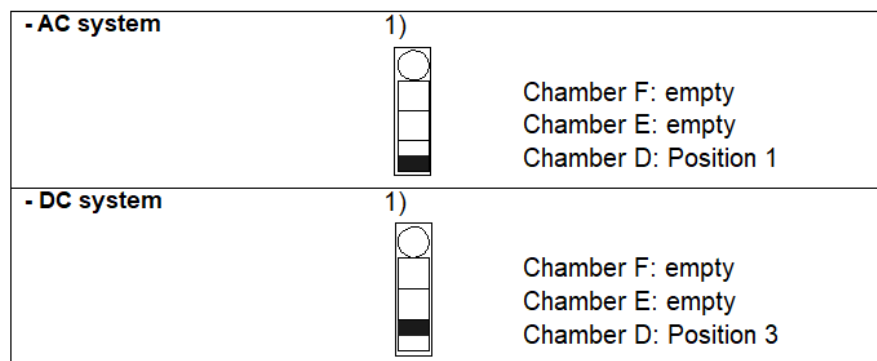
---

**IMPORTANT:** The factory setting for the CSPCI shelf's power supply coding is always set to ACPCI. To use DC

power supplies (DCPCI), you must change the coding as indicated in Figure 17.



**1) Coding of power supplies:**



**Figure 111: Coding for power supply configurations ACPCI/DCPCI**

- 4) Insert the DC cable in the socket (4) on the CSPCI box.
- 5) Strip away the cable insulation from the two DC cables (5) up to the shield (if not already done in advance).
- 6) Secure the DC cable shield (use a cable tie with metal shield to get a 360° shield connector, part no.:PNQ:1036026) to the cord grip provided for this purpose (6).

- 7) Route the DC cable out through the cable duct (7) on the MCM board and screw the MCM board back onto the CSPCI shelf.

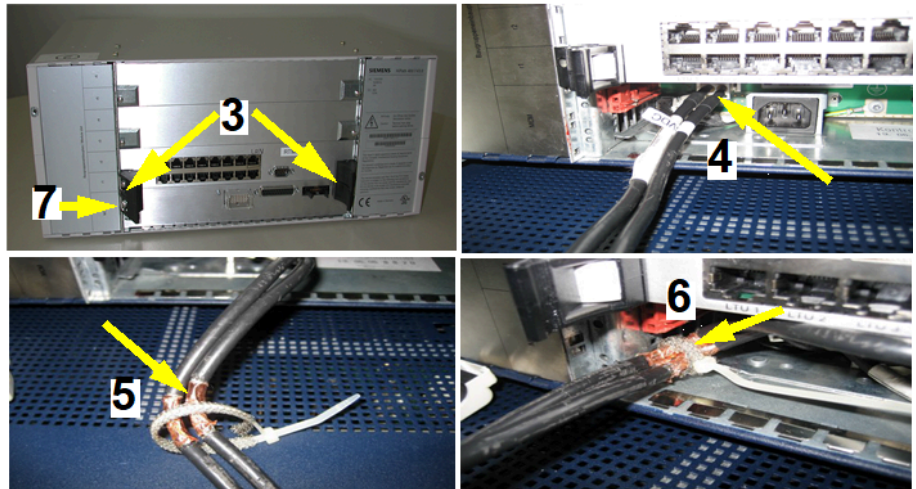


Figure 112: Attaching a DC cable to the CSPCI box

**NOTICE:** A ferrite core must be attached to the relevant AC cables in order to prevent the system being impacted by external atmospheric interferences, such as radiation (see [Section 4.7, "Attaching the Ferrite"](#)).

- 8) Once the -48V cable is connected, check that the correct jumper is plugged into the designated plug connector for the LPC80 (see [Figure 19](#)).

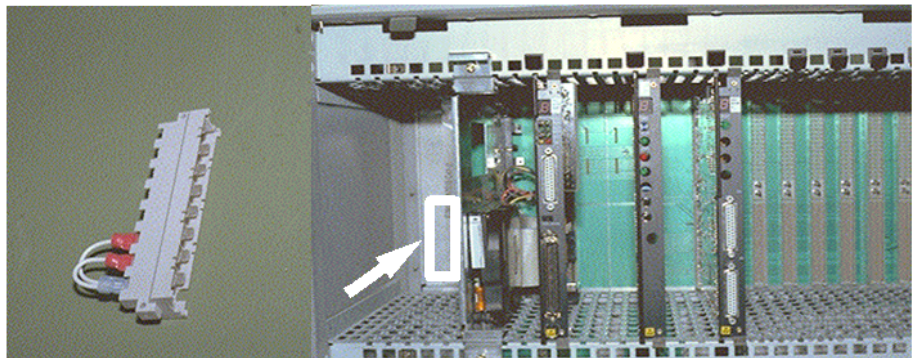


Figure 113: OpenScope 4000 jumper

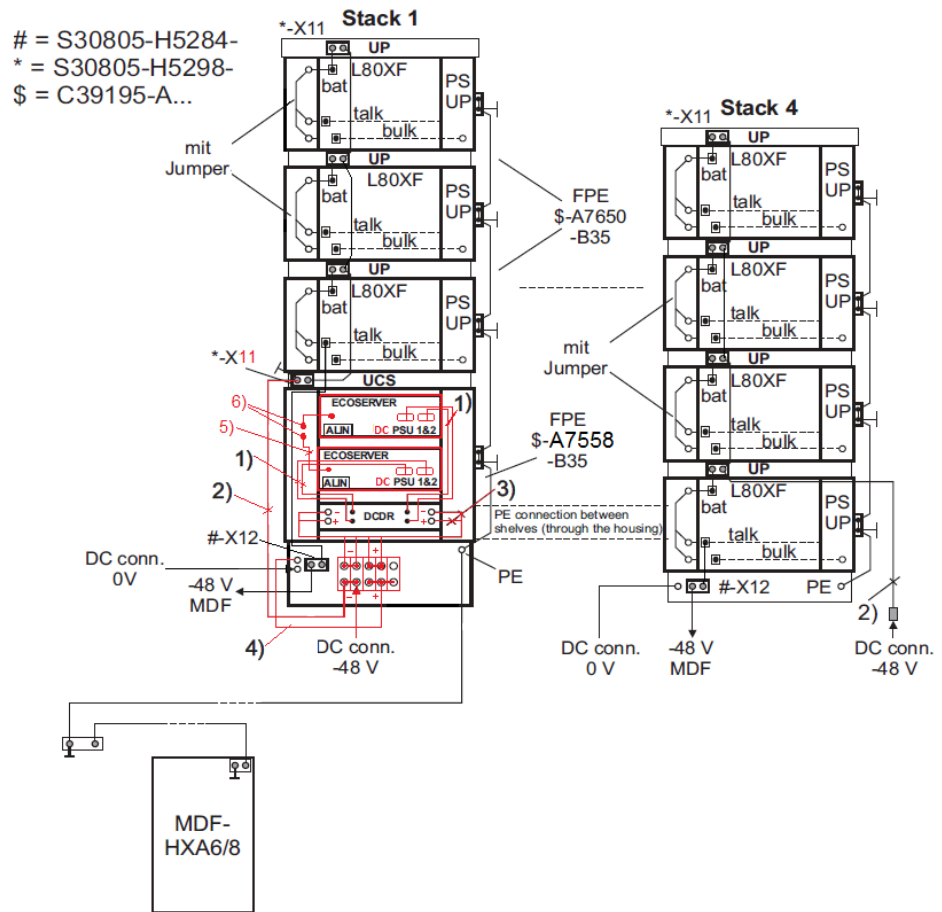
### 7.10.4 Connecting the DC Cable to the EcoServer

If the DC cable has not already been attached to the EcoServer at the factory, proceed as follows [Section 7.10.3, "Attaching a DC Cable to the CSPCI Box"](#).



Figure 114: DC power supply for EcoServer

### 7.11 DC Connection with UP/L80XF Cabinet, I.M.



Nr. Sachnummer / No code no.	Bez. / design	Bemerkung / remark von / from --> nach / to
1) C39195-A7944-B56	DC Cable 2.5m	From DCDR --> to DC PSU of the EcoServer
2) C39195-A7944-B33	Leitung	From UCS --> to DC terminal block (remove the clear tap to connect into the DC terminal block) From UP --> to DC-Ansch.-48V
3) C39195-Z70-C91	CABLE 16MM2 BLACK	From DC terminal block --> to DCDR
4) C39195-A7556-B540	Cable 0V	From DC terminal block --> to system housing
5) C39195-A7514-B80	Cable 80cm	Cable for EcoServer equipotential bonding
6) H60118-B4012-Z1	Screw	Screw for EcoServer equipotential bonding cable fixation

**IMPORTANT:** In Canada and U.S., a DC input configuration is not available.

**Figure 115: DC connection with UP/L80XF cabinet, nonredundant (IM Version)**

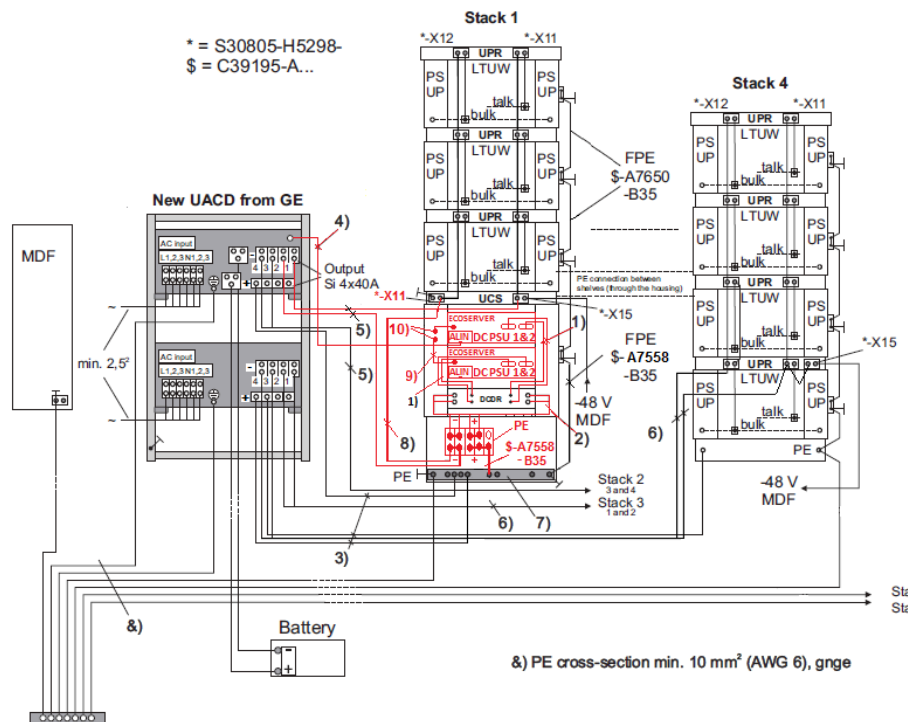
## 7.12 AC-to-DC Connection with a Redundant LTUW Cabinet

In systems with redundant power supply, there are two PSUP power supplies per LTUW. A 48 V output is provided to each power supply from a separate power box using the backplane, that is, the ~230 Vac is directly connected to the power box and not to the system.

An AC-powered OpenScope 4000 supports one stack of two UACD cabinets.

An external battery connection can also be used to support the power supply.

**IMPORTANT:** In North America, an external battery is not supported.



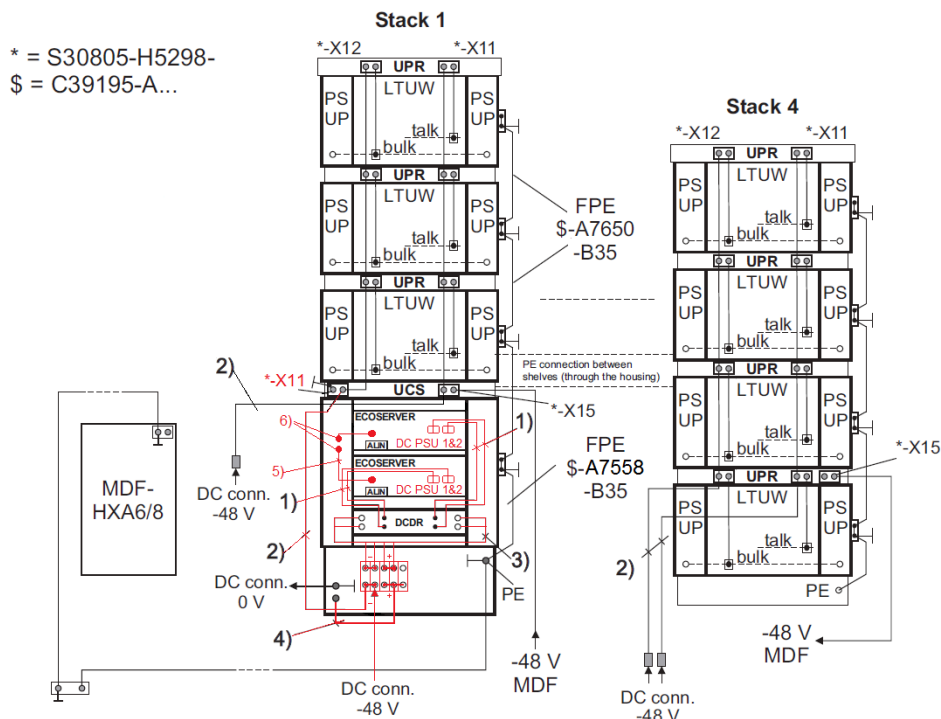
Nr. Sachnummer / No code no.	Bez. / design	Bemerkung / remark von / from --> nach / to
1) C39195-A7944-B56	DC Cable 2.5m	From DCDR --> to DC PSU of the EcoServer
2) C39195-Z70-C91	CABLE 16MM2 BLACK	From DCDR --> to terminal block

**Connecting to the Mains and Power Supply**  
 DC Connection with Redundant UPR/LTUW Box, I.M.

Nr. Sachnummer / No code no.	Bez. / design	Bemerkung / remark von / from --> nach / to
3) C39195-A7556-B540	+ Leitung	From UACD, DC terminal block --> to 0V-Schiene
4) S30122-X8011-X12	New ALIN Cable	From GE UACD --> to EcoServer
5) C39195-A7944-B16	Leitung	From UACD --> to Stack 1-2
6) C39195-A7944-B17	Leitung	From UACD --> to Stack 3-4
7) C39165-A7080-D1	0V-Schiene	wird im Stack 1 an die Rollenplatte montiert
8) C39195-A7954-B33	DC-CONNECT. CABLE	From UCS --> to DC terminal block (remove the clear tap)
9) C39195-A7514-B80	Cable 80cm	Cable for Ecoserver equipotential bonding
10) H60118-B4012-Z1	Screw	Screw for Ecoserver equipotential bonding cable fixation

**Figure 116: AC/DC connection with redundant UPR/LTUW shelves + UACD (IM version)**

**7.13 DC Connection with Redundant UPR/LTUW Box, I.M.**



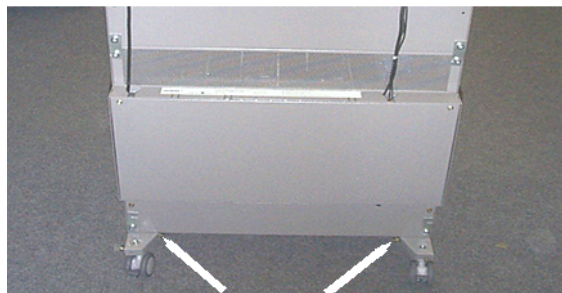
Nr. Sachnummer / No code no.	Bez. / design	Bemerkung / remark von / from --> nach / to
1) C39195- A7944-B56	DC Cable 2.5m	From DCDR --> to DC PSU of the EcoServer
2) C39195- A7944-B33	Leitung	From UCS --> to DC terminal block (remove the clear tap to connect into the DC terminal block) From UPR --> to DC-Ansch.-48V
3) C39195-Z70- C91	CABLE 16MM2 BLACK	From DC terminal block --> to DCDR
4) C39195- A7556-B540	Cable 0V	From DC terminal block --> to system housing
5) C39195- A7514-B80	Cable 80cm	Cable for Ecoserver equipotential bonding
6) H60118-B4012- Z1	Screw	Screw for Ecoserver equipotential bonding cable fixation

Figure 117: DC connection with redundant UPR/LTUW shelves (IM version)

### 7.13.1 Connecting the Battery to the Power Box, I.M.

To connect an external battery to the OpenScape 4000:

- 1) Connect the 0 V supply from the battery to the roller base of the power box (see [Figure 24](#)).



The arrows indicate the points where a 0 V battery connection is made to the power box.

Figure 118: 0 V battery connection

## Connecting to the Mains and Power Supply

- Attach the 48 V supply from the external battery to the cable drawn from the system (see [Figure 25](#)).

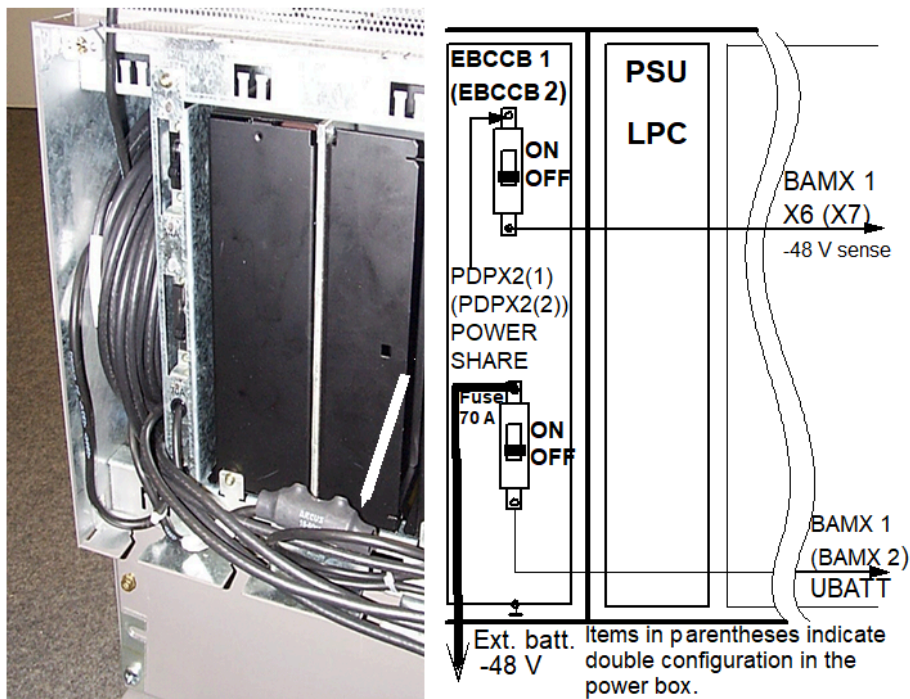


Figure 119: External battery connection to power box (back view)

### 7.13.2 Connecting the MDF for a Non-redundant, System, I.M.

---

**IMPORTANT:** In Canada and U.S., the UPS provides AC power only. It is not a source of DC power.

---

The power supply for the main distribution frame is branched from extension boxes 1 and 2 and connected to the main distribution frame by means of fuse modules (Si1/Si2), each with 1.6 A fuses (see [Figure 26](#) and [Figure 27](#)). The “48 V connectors from the MDFs can be combined as required. Ensure that the number of MDFs connected at a fuse does not exceed the overall power requirement for each 1.6 A fuse.

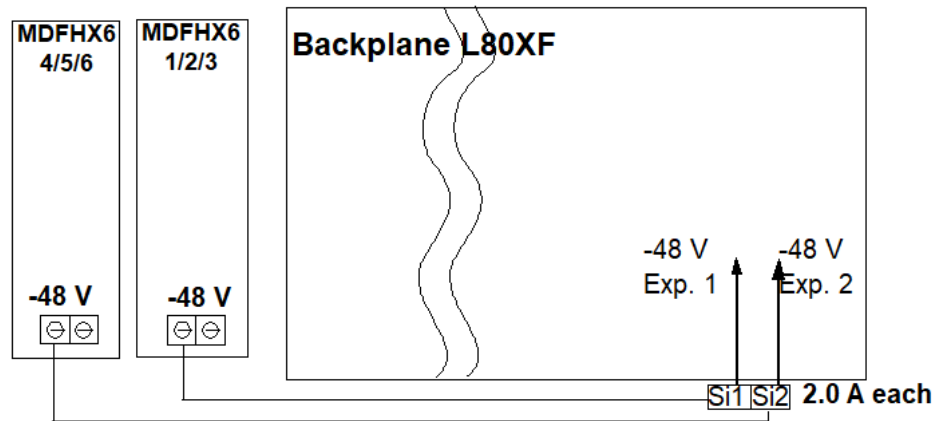
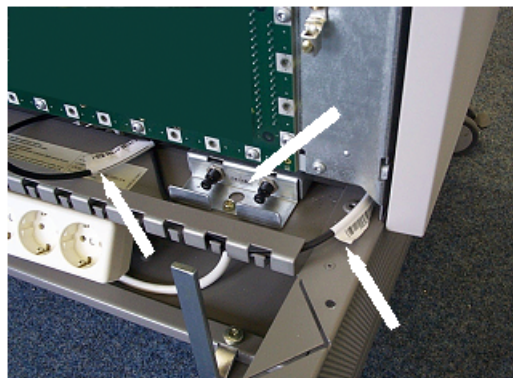


Figure 120: Example of a “48 V connection for main distribution frame (nonredundant)

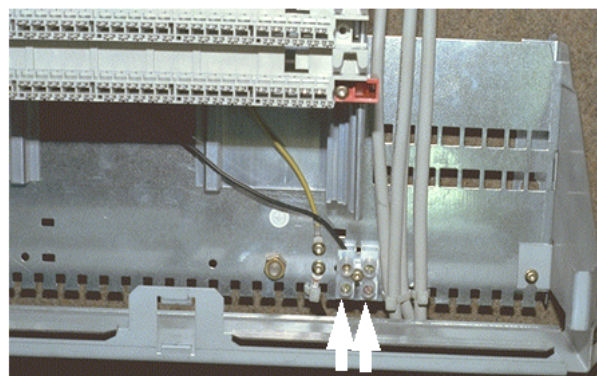


The arrows indicate the -48 V cables and fuse module (Si1, Si2). The cable from Si1 is connected to MDF 1/2/3. The cable from Si2 is connected to MDF 4/5/6.

Fuses:

L80XF = 2.0 A  
LTUW (X15) = 1.6A

Figure 121: -48 V fuse module for MDF (nonredundant)



The arrows indicate the connection for -48 V on the main distribution frame. The -48 V cables from the various fuses must be connected here.

If necessary, this connection can also be connected to other main distribution frames (up to a maximum power consumption of 1.6 A per fuse).

Figure 122: -48 V main distribution frame connection

## 7.14 AC-to-DC Connection with AP 3700

The following shows the AC and DC connections for the AP 3700 (base and expansion cabinet).

### 7.14.1 AC Connection AP 3700-9/AP 3700-13

Figure 29 shows the power inputs for the AP 3700-9 and AP 3700-13.

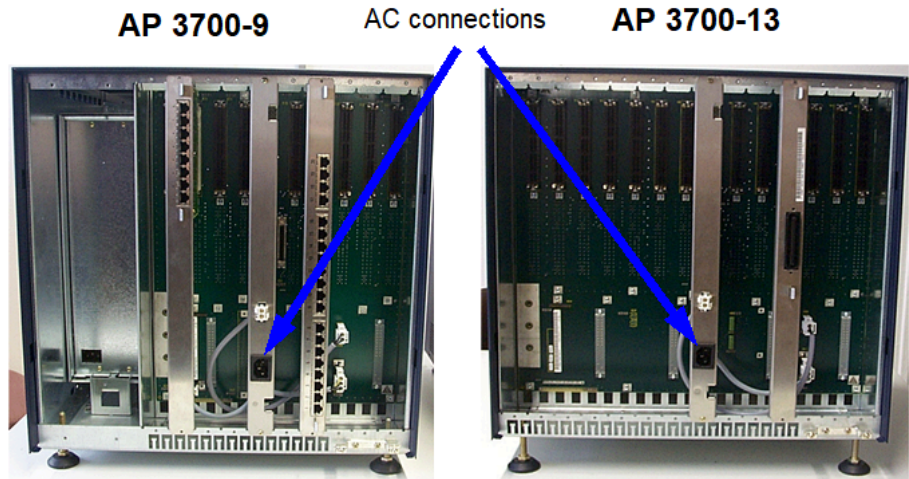


Figure 123: AC connections AP 3700-9/AP1100 3700-13

### 7.14.2 DC Connection AP 3700-9/AP 3700-13

Figure 30 shows the DC inputs for the AP 3700-9 and AP 3700-13.

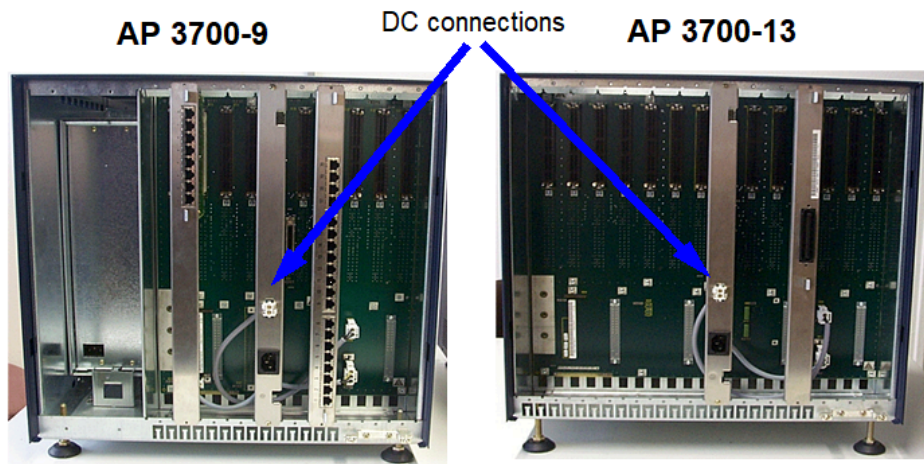
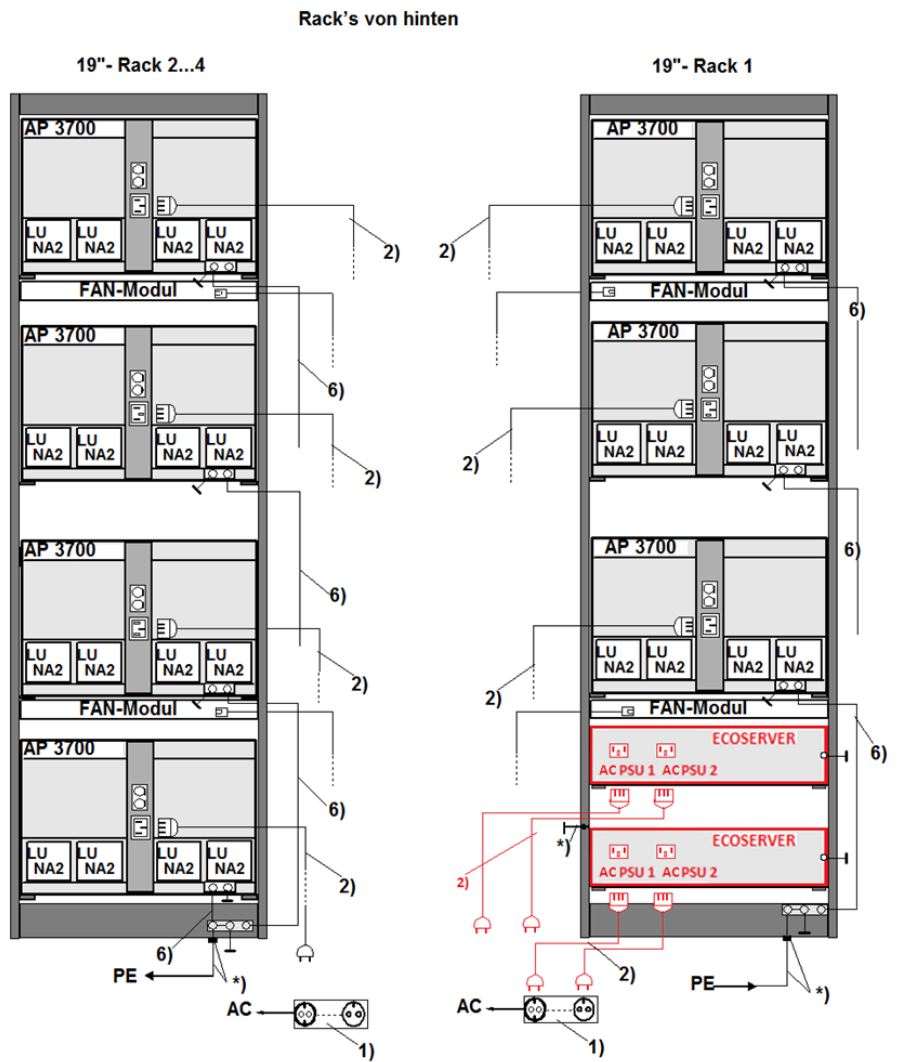


Figure 124: DC connections AP 3700-9/AP 3700-13

### 7.14.3 AC Connection AP 3700 in 19" Cabinet



\*) Achtung:  
sichere Erdverbindung, sternförmig von der ext. Erdschiene zum Schrank, herstellen.  
Leitung mit Kabelbinder befestigen

\*) Set up a secure star-shaped earth connection from the earth bar to the cabinet. Secure cable with cable ties.

Figure 125: AC connection AP 3700 in 19" cabinet

### 7.14.4 DC Connection AP 3700 with DCDR (Fuse Unit)

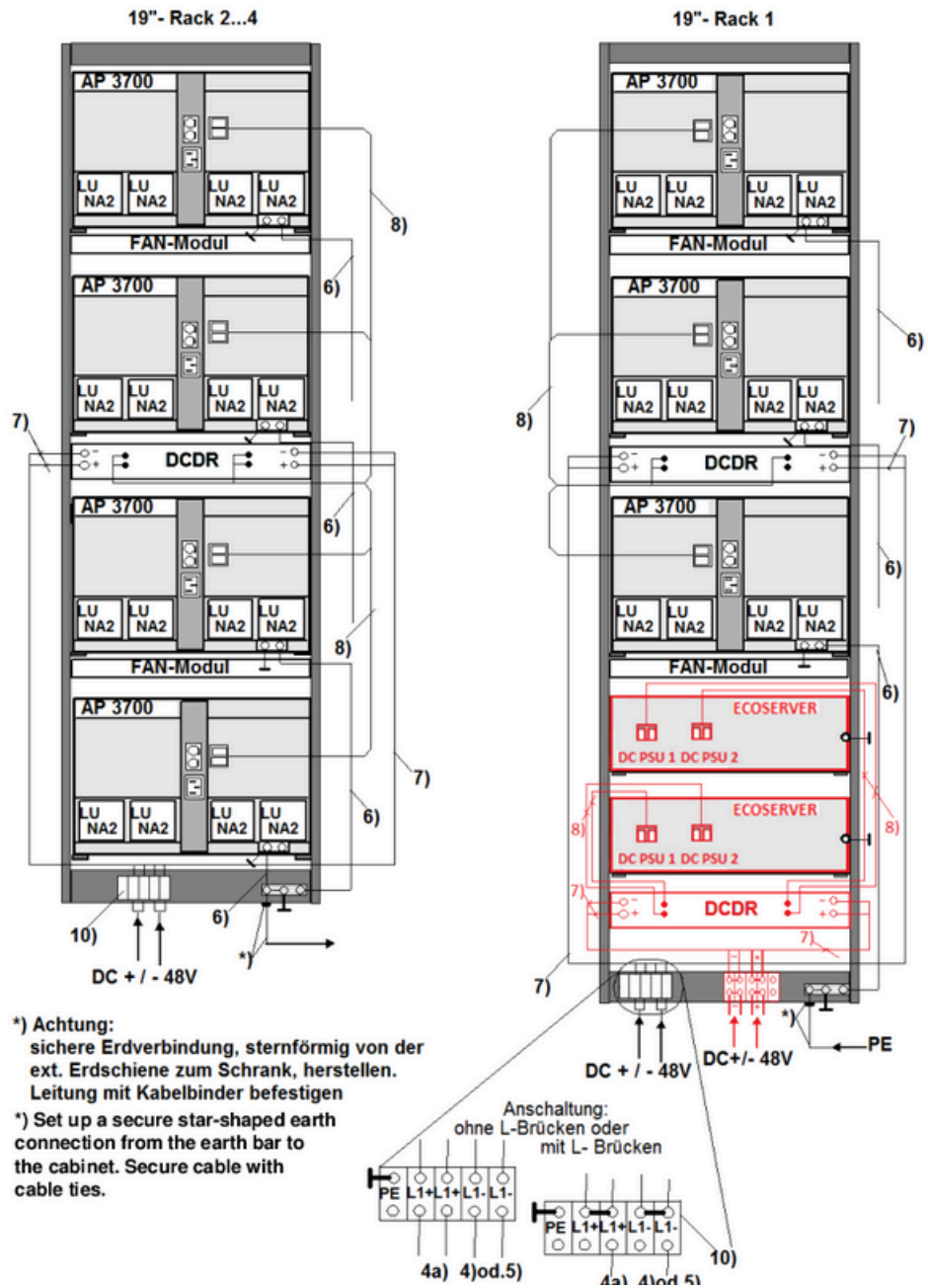


Figure 126: DC Connection AP 3700 with DCDR (Fuse Unit)

Table 2 lists the cables to be used when the AP 3700 is to have AC/DC wiring in the 19" cabinet (see the numbers in Figure 31, Figure 32, Figure 33 and Figure 36).

**Table 2: Cables for AP3700 AC/DC connection in the 19" cabinet**

No.	Part number	Name	From	To	Remark
1)	from the rack vendor	AC multiple socket outlet	19-inch rack, AC multiple socket outlet	Housing installation	
2)	C39195-Z7001-C17 or C39195-Z7001-C19	Power cable	CSPCI / AP 3700	AC multiple socket outlet 230V	f. IM f. NA
4)	C39195-A7944-B16/17	Cable	UACD (1), (2) -48V, Bulk/Talk -> -48V, Bulk/Talk ->	Rack 1 ... 4, DC connection - X10 or terminal block	
4a)	C39195-A7556-B540	Cable	UACD (1), (2), DC+/-48V	DC Terminal block	
5)	C39195-A7954-B33	Cable	DC -48V feed	Rack 1 ... 4, DC connection - X10	Interim solution
6)	C39195-A7650-B250	Cable 10 mm2	AP 3700 - grounding connector	Central ground point in the rack	PE
7)	C39195-Z70-C91	Cable 16 mm2 black	DCCR	DC Terminalblock connection	
8)	C39195-A7944-B56	Cable +/- 48 V	19"-Rack, DCCR Si F01/F02/F32 u. F31	EcoServer / AP 3700	Series
9)	C39195-A7488-B800	Cable	Rack, central ground point	External earth bar	
10)	S30122-X8018-X2	Terminal block	Mounted in the 19" rack		Will be delivered
11)	C39195-A7240-B500 oder " - " -B951	Cable - 48 V	Fuse cover	HVT	

No.	Part number	Name	From	To	Remark
12)	C39195- A7267-A372/ "- "-A373 S30267- Z196- A150/250	Cabling unit	REALS-BG BP-Stecker 'X116'	HVT	

### 7.14.5 DC Connection AP 3700 with DCDR (DC Kit for 19-Inch Cabinet)

This chapter describes DC connection to the DCDR fuse unit if the delivery includes a kit for 19-inch cabinet installation in the AP 3700 cabinets.

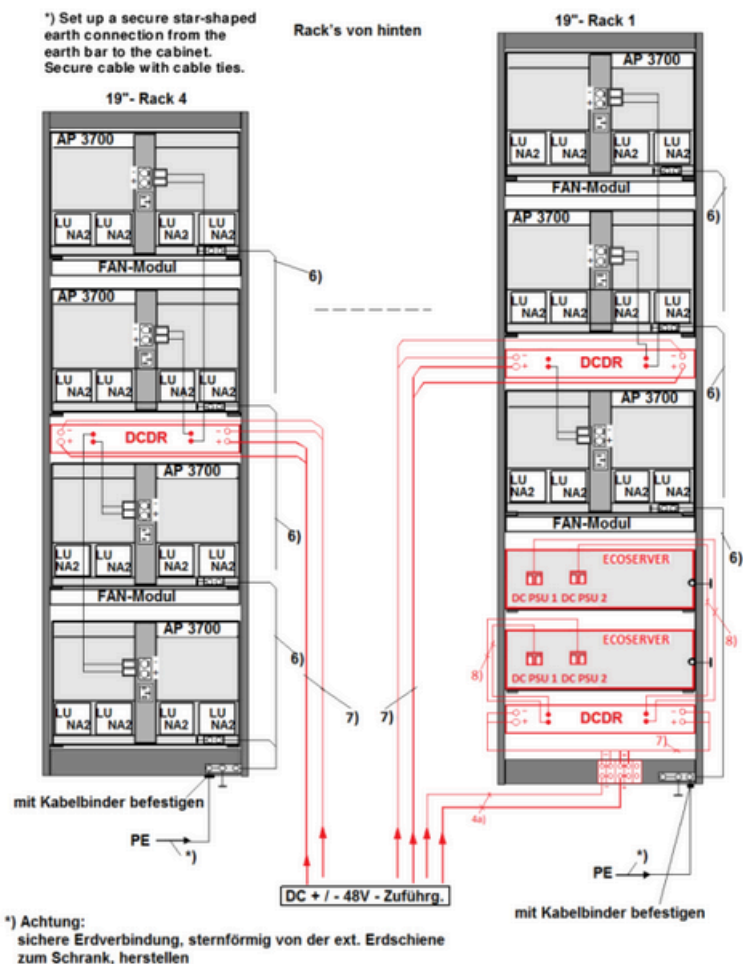


Figure 127: DC connection AP 3700 with DCDR (DC kit for 19-inch cabinet)

### 7.14.6 DCDR Connection from Behind

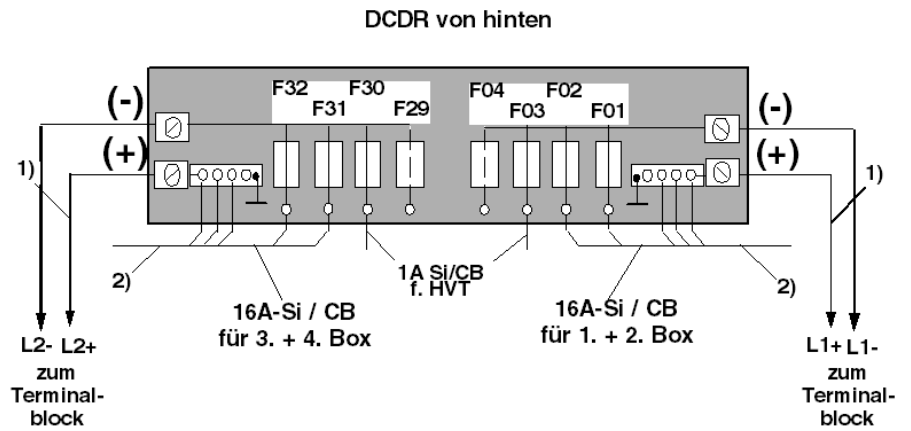


Figure 128: DCDR connection from behind

Table 3 lists the cables to be used for DC wiring in the AP 3700 in the 19-inch cabinet (see numbering in Figure 34).

Table 3: Cables for DC connection of AP 3700 in the 19-inch cabinet

No.	Part number	Name	From	To	Remark
1)	from DCDR manufact. S30122-X8019- X4	Cable 2 x +/-48V, 162	19" rack, DCDR	Terminal block in 19-inch rack, S30122- X8018-X2	
2)	C39195-A7944- B56	Cable +/- 48V	19" rack, DCDR Si/CB F01/F02/ F32 and F31	CSPCI / AP 3700	
3)	Installation materials	Cable 10 mm <sup>2</sup>	AP 3700 - grounding connector	Rack, central ground point central rack PE point	PE
4)	C39195-A7944- B16/17 from S30805-G5405-X	Cable -48 V, 102	UACD (1), (2) -48 V, Bulk/Talk ->	Rack 1 ... 4, Terminal block	
5)	C39195-A7556- B540 from S30805-G5405-X	Cable 0 V, 102	UACD earth bar	Rack 1 ... 4, Terminal block	

## Connecting to the Mains and Power Supply

No.	Part number	Name	From	To	Remark
6)	C39195-A7488-B800	Cable 35 mm <sup>2</sup>	Rack, central ground point  central rack PE point	External earth bar	PE

Figure 35 shows the DCDR fuse unit for the 19" installation version



**Figure 129: DCDR fuse unit for 19" installation**

### Technical specifications

Dimensions: Width = 435 mm, Depth = 205 mm, Height = 90 mm, Installation height = 2 U

Weight: Complete with fuses approx. 4kg

The power supply connection cables are also supplied (see SK S30122-K7698-X).

Fixing screws for DCDR and the terminal block for rack installation should be obtained from the rack vendor for the specific rack used.

---

**NOTICE:** The breaker panel unit DCDR must always be installed above a CSPCI or AP3700-9/13.

---

Operating characteristics of DCDR:

- Operating voltage: 80 Vdc (the OpenScope 4000 system always requires 60 Vdc)
- Total current per side: 80 A
- Maximum nominal current for automatic circuit breaker per slot: 25 A

---

### IMPORTANT:

- The approved 16-A automatic circuit breaker (V39118-Z7180-A6) should always be used to connect the cabinets CSPCI, AP3700-9, and AP 3700-13.

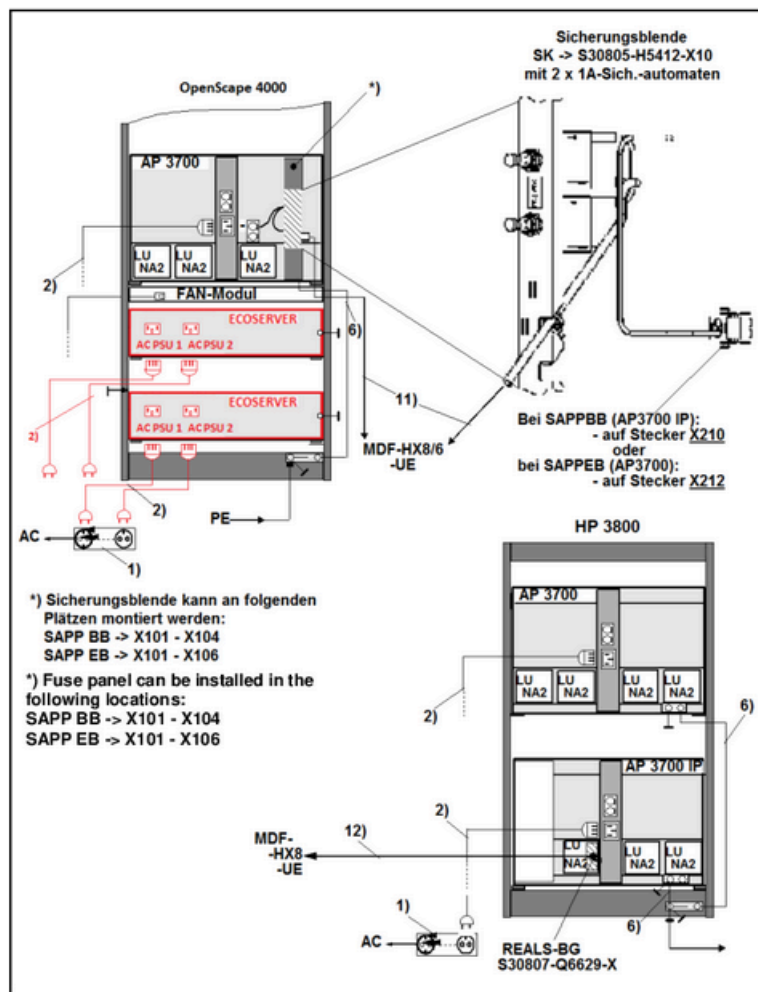
- In the case of LM orders based on the project planning procedures, the 16-A automatic circuit breakers are automatically planned depending on the configuration.
- For each DCCR, two 1-A automatic circuit breakers (V39118-Z7180-A8) are provided in advance for the connection of external devices.
- An order with part number is required in all other cases (for example, additional requirements).

- Cable cross-section: 35 mm<sup>2</sup>
- Short-circuit current: 3000 A

### 7.14.7 DC Connection of AP 3700 to the MDF

To set up a -48-V connection from an AP 3700 cabinet to an MDF, an appropriate fuse panel must first be installed on the back of the AP 3700 because this does not have a -48-V fuse for the MDF.

For information on where to install and connect the fuse panel, refer to [Figure](#).



## Connecting to the Mains and Power Supply

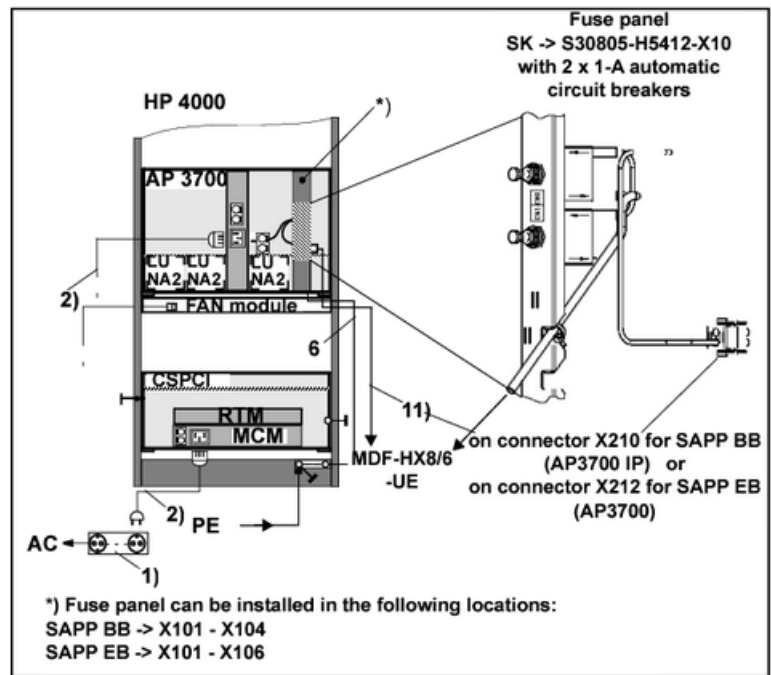
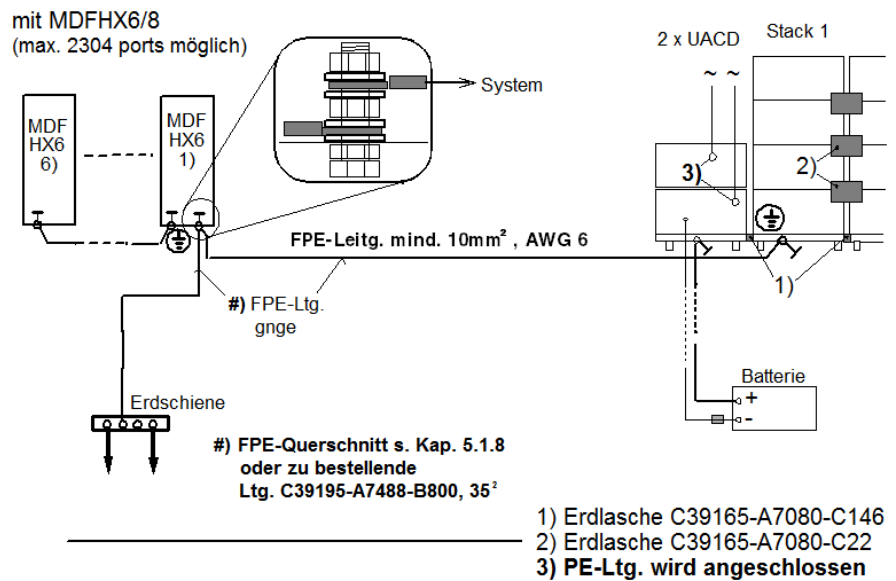


Figure 130: DC connection of AP 3700 to the MDF

### 7.14.8 Earth and 0 V power rating - for stacking



mit Fremd-HVT

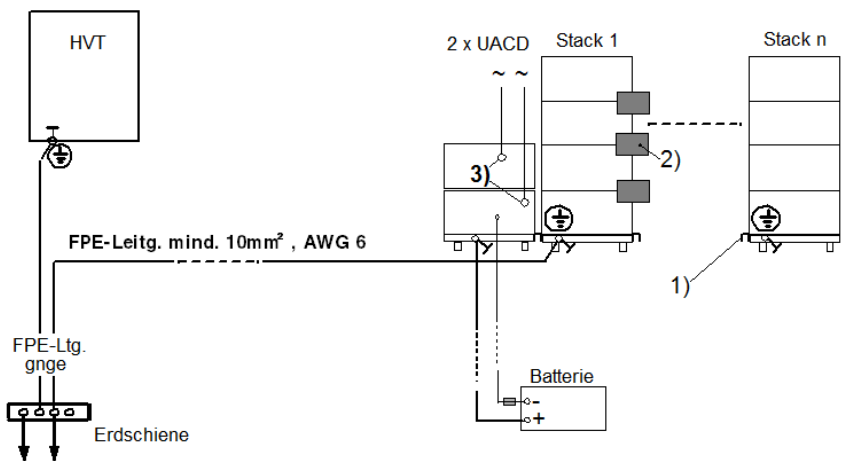


Figure 131: Earth and 0 V power rating - for stacking

### 7.15 UACD (GE) 19-Inch Installation

**NOTICE:** A Installation without 19 inch is not supported.

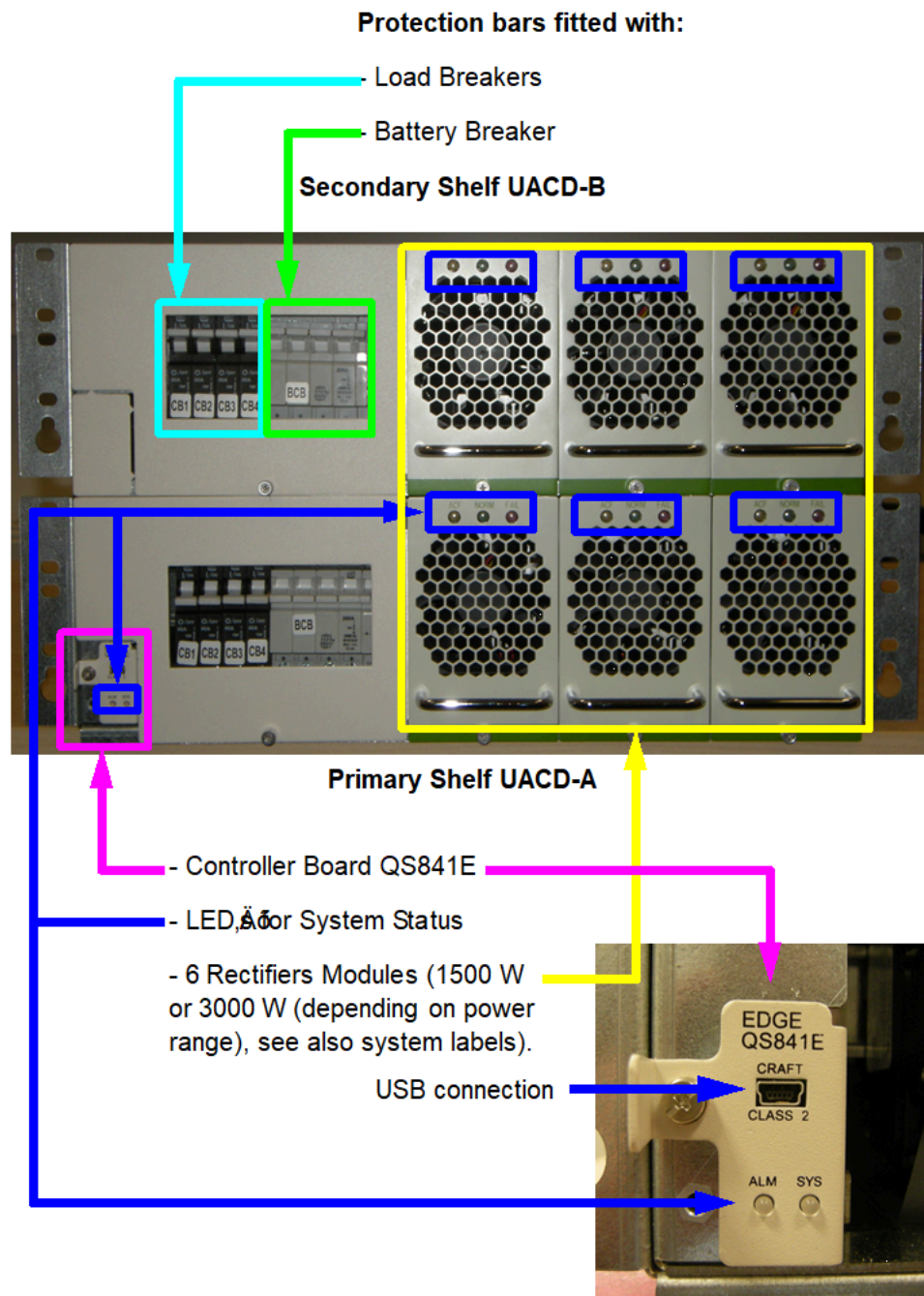
The UACD power box (Lineage Power) is a new AC/DC power box for use in 19-inch cabinets which replaces the old UACD (PSR930/PSR930E).

It consists of the following 19-inch mounting units:

- Primary Shelf UACD-A (with the QS841E controller board)
- Secondary Shelf UACD-B

## Connecting to the Mains and Power Supply

**IMPORTANT:** - The new UACD power box may only be serviced by authorized service personal. - All UACD lines (in the 19" cabinet) must be secured with an appropriate cord grip (e.g. cable tie).



**Figure 132: UACD-A&B - Front View (Details)**

**NOTICE:** The equipment comes with all circuit breakers already equipped!

The UACD expansion cabinet (UACD Secondary Shelf) has the same structure as the base cabinet minus the base controller.

---

**IMPORTANT:** - Before starting up the power, ensure that all rectifiers modules on the front are securely screwed into the shelf to guarantee a secure contact.

---

### 7.15.1 Connect the power supply to an UACD

---

**IMPORTANT:** Always consider personal safety before beginning any procedure. Review the Safety section.

---



**WARNING:** Risk of injury resulting from following items: - Be aware of the presence of unfused battery potential in the vicinity. - Use only insulated tools. - Make sure the system is properly grounded per the National Electrical Code and local building codes. - Remove all metal jewelry before beginning the installation.

---

#### Installation Material:

- Wire cutters and strippers
- 18 to 22 AWG wire
- Jewelers screwdriver (Flat and Phillips)
- Small needle nose pliers
- Digital meter, +/- 0.02%
- Screw Drivers (flat-blade and Phillips)
- ESD wrist strap
- Wire-wrap tool or Amp alarm punch-down tool

#### 7.15.1.1 Install Primary Shelf A

##### Hardware:

Attach each shelf to the frame using a minimum of four (two on each side) of the 12-24 screws included with the shelf. Torque to 30 in-lbs using 5/16" nut driver. Allow a minimum 2 inch clearance at back of shelf for rectifier airflow, no vertical spacing is required.

##### Wiring Guidelines:

All wiring is located on the rear of the shelf:

- commercial ac input wiring,
- dc output wiring,
- inter-shelf signal connector
- LAN port
- alarm wiring to general office alarms
- Load and battery connections

## Connecting to the Mains and Power Supply

Make all electrical connections using the proper crimping tools and dies. Torque to values specified. Verify all wiring complies with the NEC and other applicable local codes. The temperature rating of the wire must be no less than 90° Celsius and should be sized using the 60° Celsius ampacity table in the NEC handbook.



**DANGER:** Risk of electric shock through contact with live wires. Only qualified personnel should install and service the UACD system and modules. Hazardous energy and voltages are present in the unit and on the interface cables and will shock or cause serious injury or death if safety precautions are ignored. Follow all safety warnings and practices when servicing this equipment.

**Table 4: UACD Interface Reference**

Interface Ref.	Description
J6	10/100 Base-T LAN/Ethernet interface (see <a href="#">Figure 39</a> )
J1	Connector for controller Input / Output (see <a href="#">Figure 39</a> )
J4	Temperature probe (see <a href="#">Figure 39</a> )
USB	USB interface on the Controller Board QS841E (see <a href="#">Figure 38</a> )
HDR3	Primary Shelf A connection to Secondary Shelf B (see <a href="#">Figure 40</a> )
HDR2	Secondary Shelf (B) connection to Primary Shelf A (see <a href="#">Figure 40</a> )

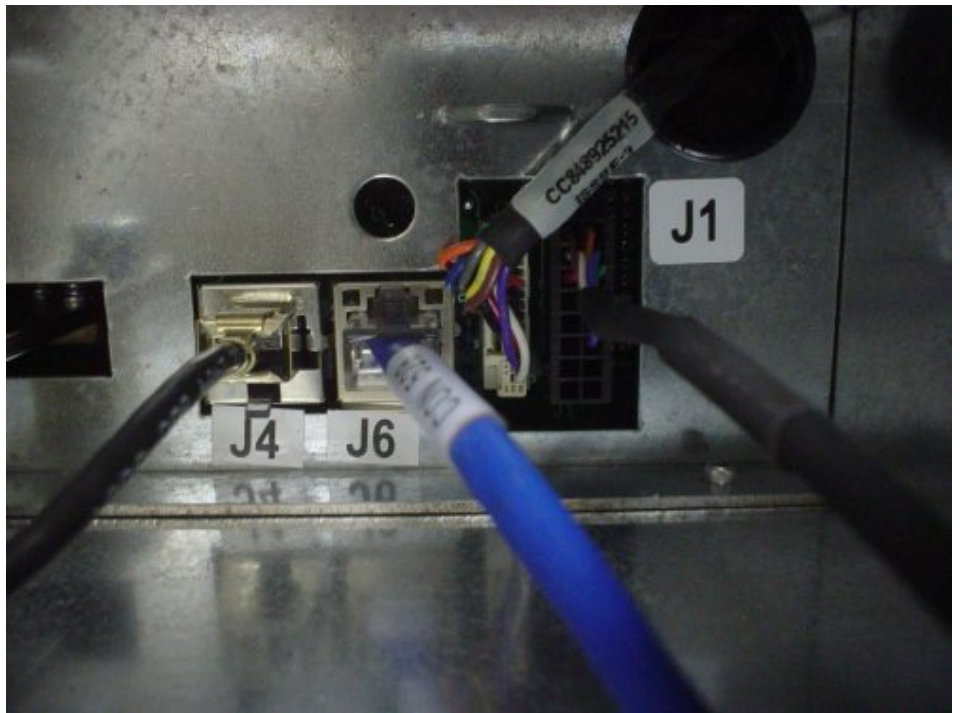
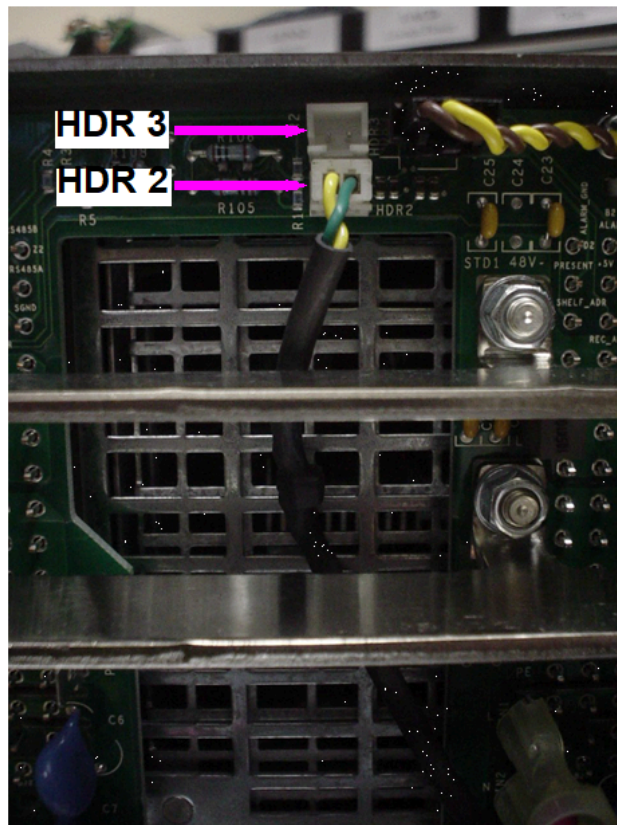


Figure 133: Reference connectors J1, J4, J6



Install DC reference and frame ground cable (see also [Figure 42](#)):

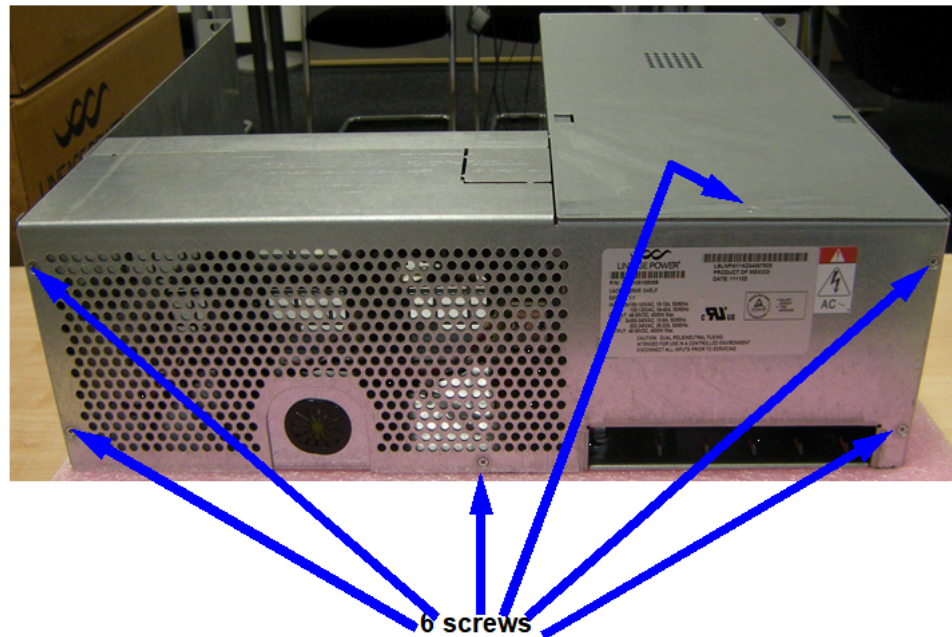
---

**NOTICE:** DC reference and frame ground cables are not included. Some installations may not require separate reference and frame ground wires.

---

**Figure 134: Reference connectors HDR2, HDR3**

1) Step 1: Remove the 6 screws and rear access cover see [Figure 41](#).



**Figure 135: Rear access cover**

Step 2: Will separate dc reference and frame grounds be used? If Yes, then use a # 10 AWG (user provided) cable, strip the insulation and install one M4 single hole lug and one M8 single hole lug to form a cable. Install the ground cable from the dc reference point to the frame point shown below. If no, then go on with c).

Step 3: Use a # 10 AWG (user provided) cable, strip the insulation and use one 3/8" single-hole lug to form a ground cable. Install the lugged cable from the M8 frame ground connection to the appropriate building ground point.

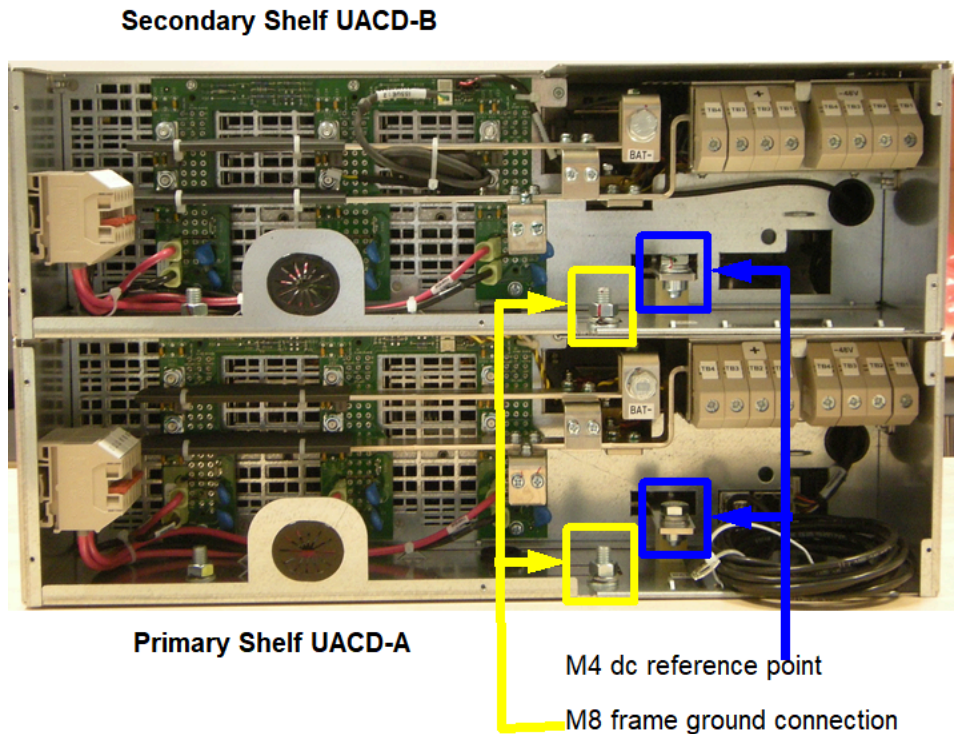


Figure 136: DC reference point and frame ground connection

### 7.15.1.2 Install Secondary Shelf B - Two shelf System

#### Install shelf to shelf busses (required only in two shelf system)

Two shelf systems consists of a Primary Shelf (A) and a Secondary Shelf (B). The Secondary Shelf (B) may be installed on top of the Primary Shelf (A), as described, or below the Primary Shelf (A). Two shelf systems share battery power through the shelf to shelf busses. Each shelf is equipped with one 200 Amp battery circuit breaker that connects one battery string to each shelf. The battery terminal connections accept up to a 1/0 AWG wire.



**WARNING:** Risk of electric shock through contact live wires. Verify all circuit breakers are in the open position before proceeding.

- 1) Remove the shelf to shelf bus bar knockout (see [Figure 44](#)).

## Connecting to the Mains and Power Supply

- 2) Take the bus bars from package (see [Figure 43](#)).



**Figure 137: Bus bar package**

- 3) Align the bus bars through the opening (see [Figure 45](#)).

- 4) Install the battery bus bars and secure with hardware (screws, see [Figure 45](#)) previously removed. Torque hardware to 60 inch lbs (see [Figure 44](#) and [Figure 45](#)).

Primary shelf A is installed on bottom and Secondary shelf B is on top in this figure.

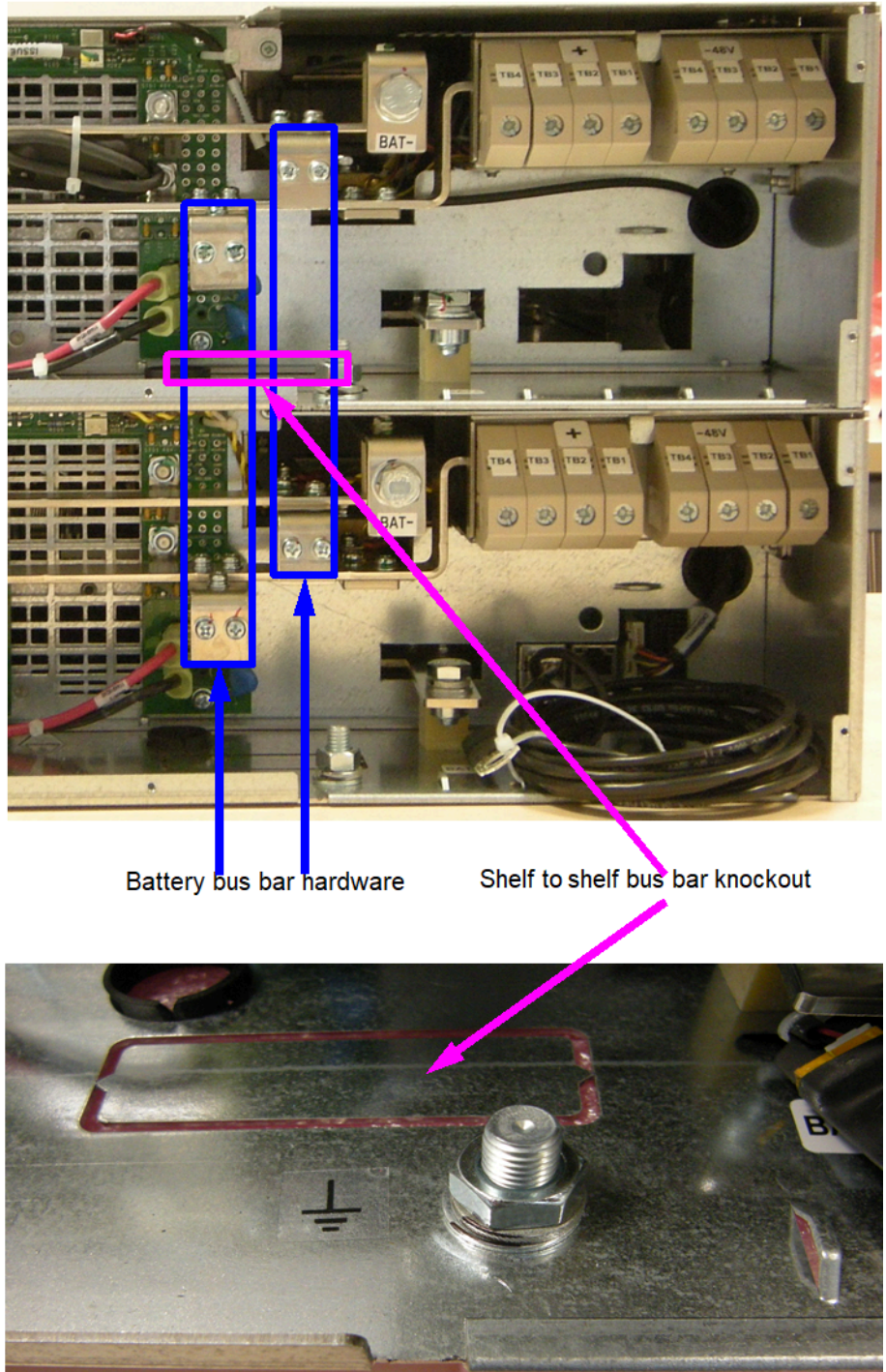


Figure 138: Install shelf to shelf bus

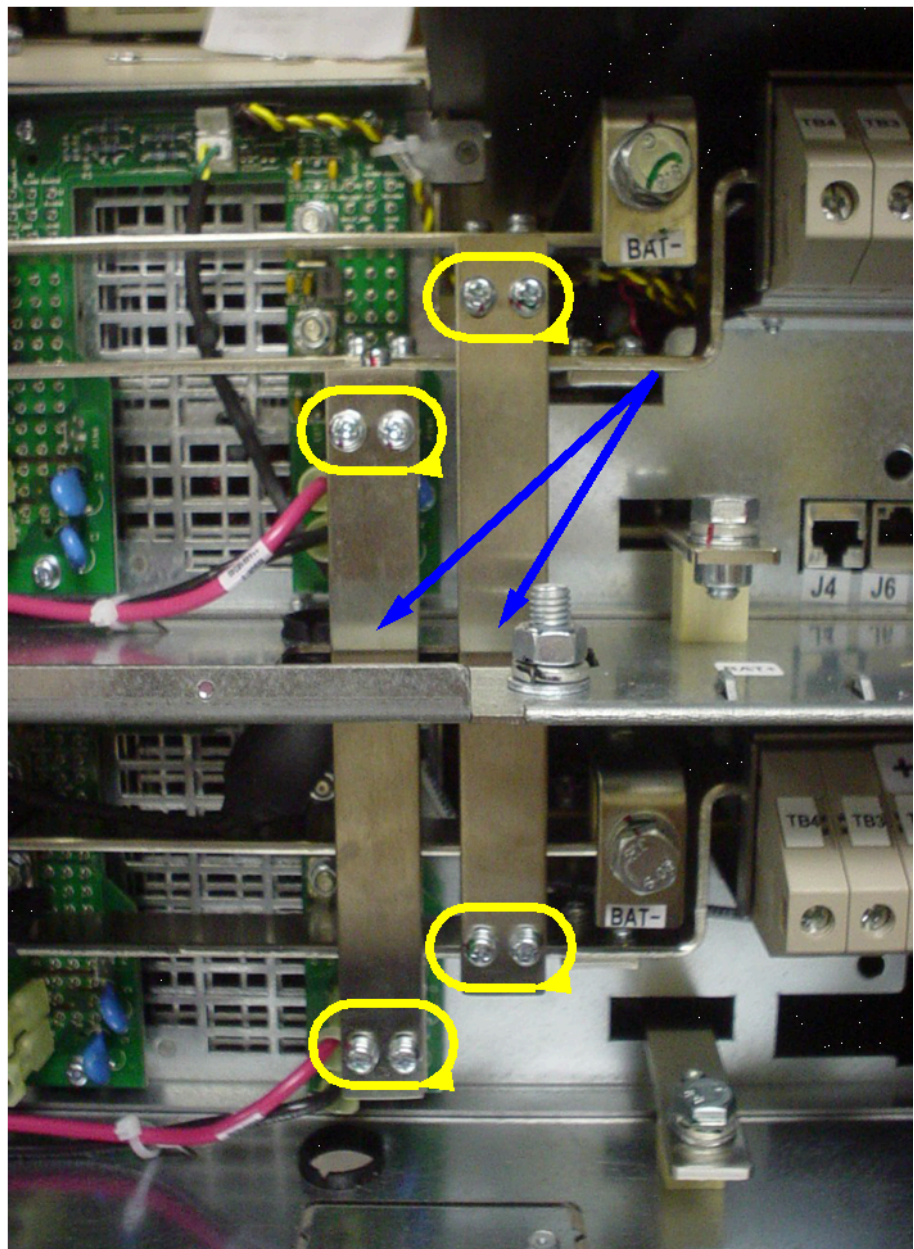


Figure 139: UACD bus bar connection

### 7.15.1.3 Shelf to shelf communication (Required only in two shelf systems)

The Pulsar controller communicates to each rectifier through a serial data communication bus. In two shelf systems, with the Primary Shelf (A) on the bottom as shown, connect the shelf-to-shelf interconnect from the top Secondary Shelf (B) HDR2 to the bottom Primary Shelf (A) HDR3 connector (see [Figure 40](#) and [Figure 46](#)). The shelf-to-shelf cable is attached to the Secondary shelf (B), connector HDR2, at the factory. The cable will be coiled and secured by a tie wrap.

- 1) Step1: Cut the tie wrap and uncoil the shelf to shelf communication cable. Route the cable through the round hole to the second shelf.

- 2) Step 2: Plug the opposite end of the cable into the HDR3 connector of the second shelf.

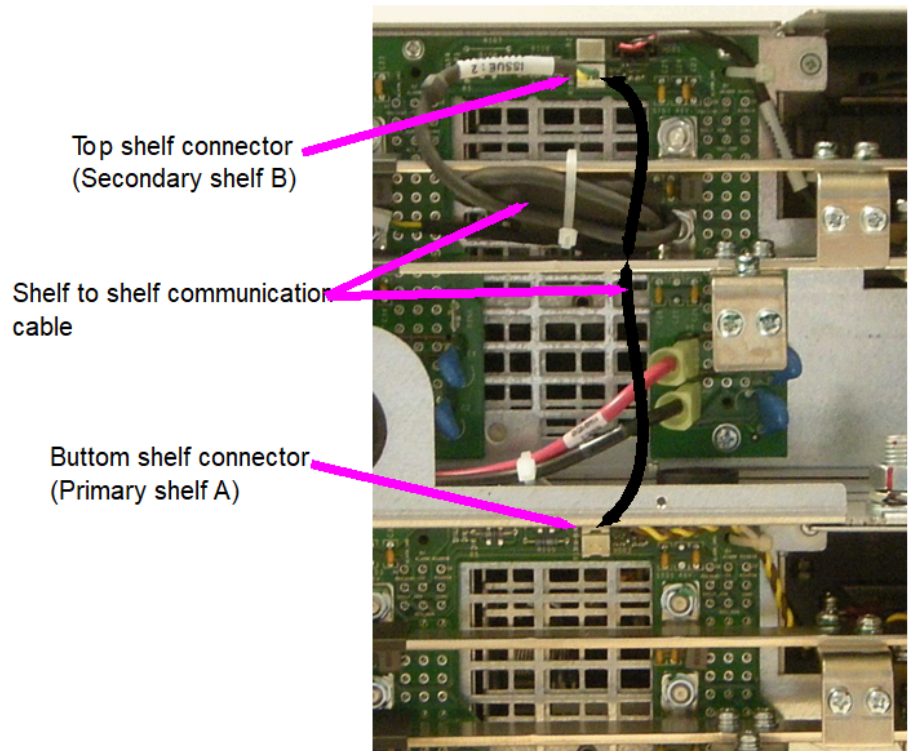


Figure 140: Shelf to shelf communication (rear view)

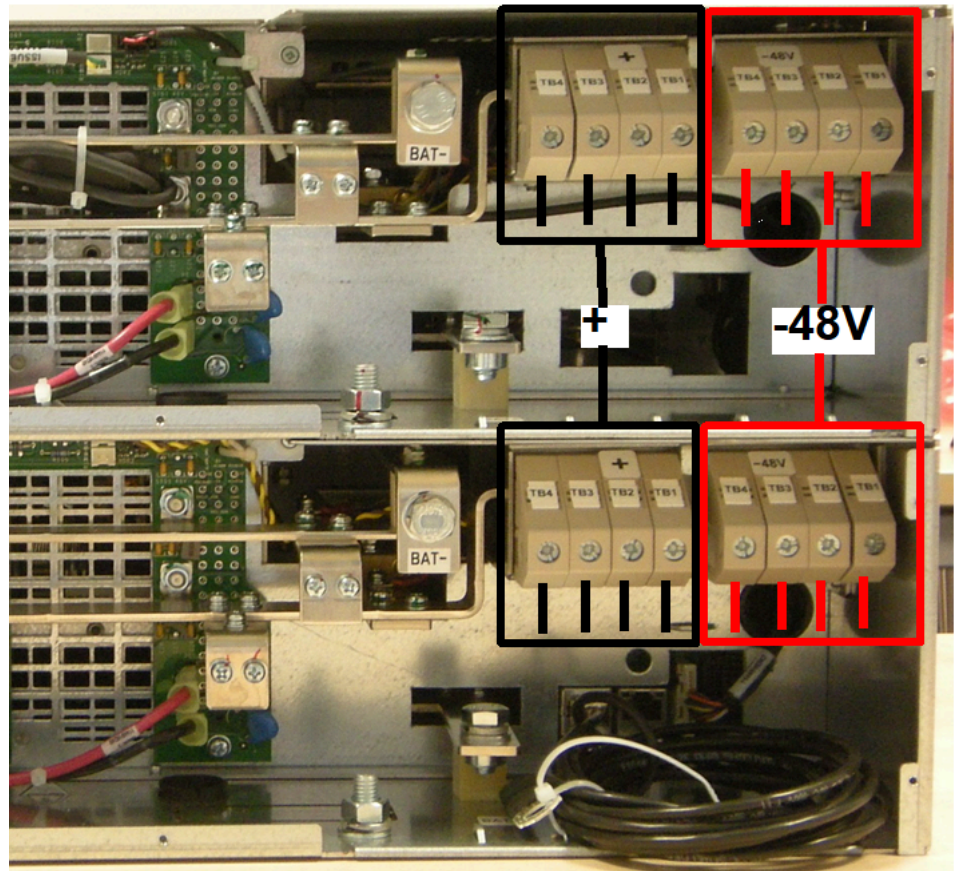
#### 7.15.1.4 Install DC load output cables

There are four 40 Amp load circuit breakers located on the front of each shelf. Load wiring connects on the rear of the shelf. Up to a 8 AWG wire can be terminated.

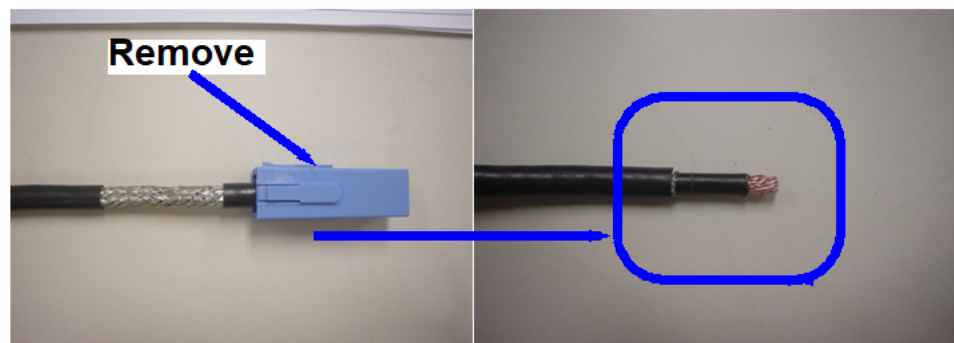
- 1) Step 1: Strip insulation from wires, insert wires into terminals. Torque connection to 20 inch lbs. Repeat for each load circuit.
- 2) Step 2: Dress and strain relieve wires in a downward direction and route the wires through the outlet on backside (see [Figure](#)).

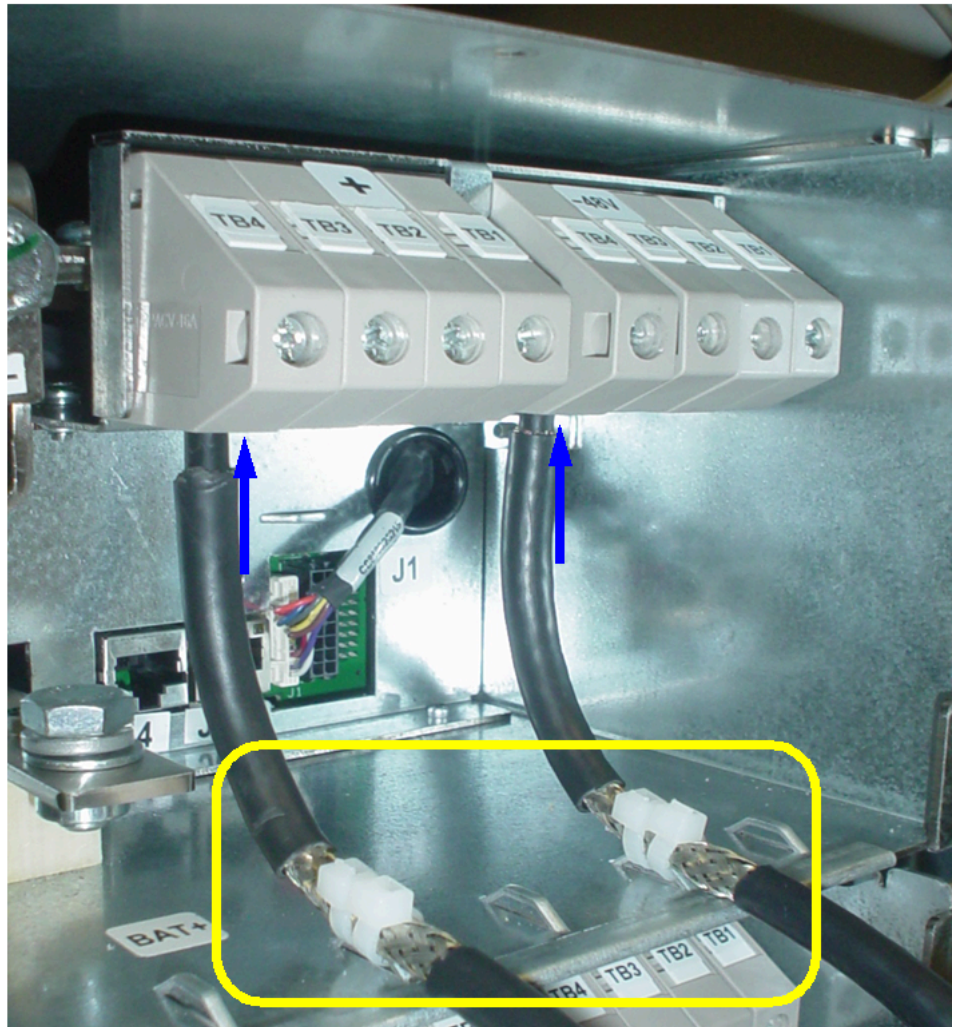
## Connecting to the Mains and Power Supply

4 Outputs (-48V) for each shelf



**IMPORTANT:** To connect the +/-48V to the system at the UACD's output terminals (see [Figure](#)), you must first remove the blue cable connector at one end of the cable supplied and strip the wire (see [Figure](#)). This cable is connected directly to the terminals.





---

**NOTICE:** To ensure a correct shielding contact of load cables to the housing, you have to strip and fix the cable with 2 cable ties as shown in the [Figure](#).

---

## Connecting to the Mains and Power Supply



### 7.15.1.5 Thermal Probes

Without thermal probes, many of the controller's battery management features will not function; Slope Thermal Compensation and Battery Reserve Time Prediction require battery temperature be monitored. If either of these features will be used battery temperature input must be connected to J4 temperature probe connector on the rear of the shelf.

Some features requiring thermal inputs are:

- Slope Thermal Compensation
- Reserve Time Prediction
- High Temperature Alarm
- Ambient High and Low Temperature Alarms
- High Temperature Disconnect

---

**NOTICE:** Temperature probes mount on top of the battery connectors. Do not mount under the lug.

---

- 1) Step 1: Install the temperature probe on the battery post as shown in the [Figure 51](#).

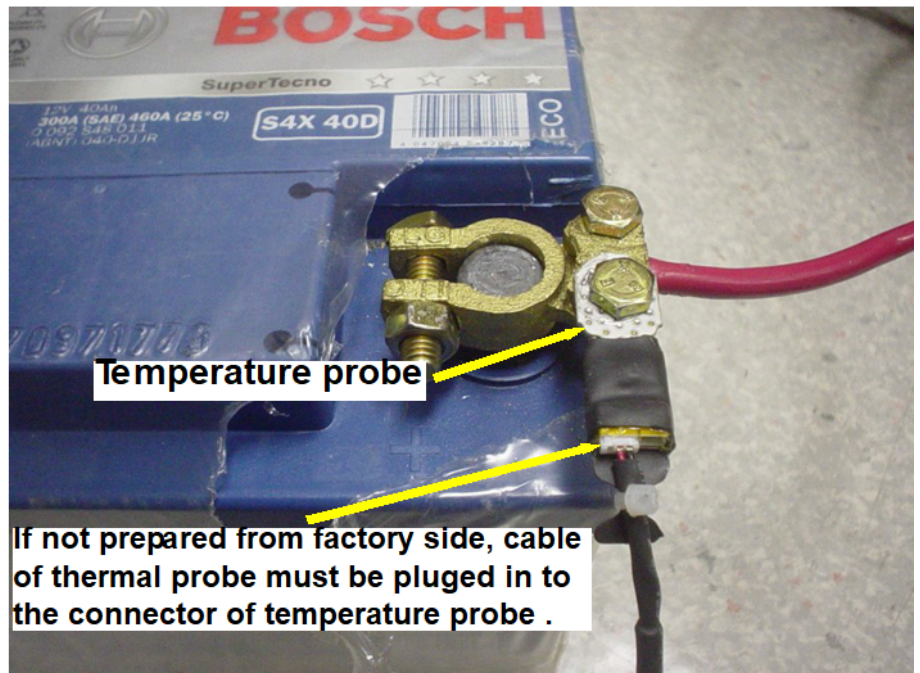


Figure 141: Thermal probe connection

## Connecting to the Mains and Power Supply

- 2) Step 2: Locate J4 on the rear of the shelf and plug-in the RJ45 connector (see [Figure 52](#)). Route the cable to the temperature probe and plug it into the connector (see [Figure 53](#)).

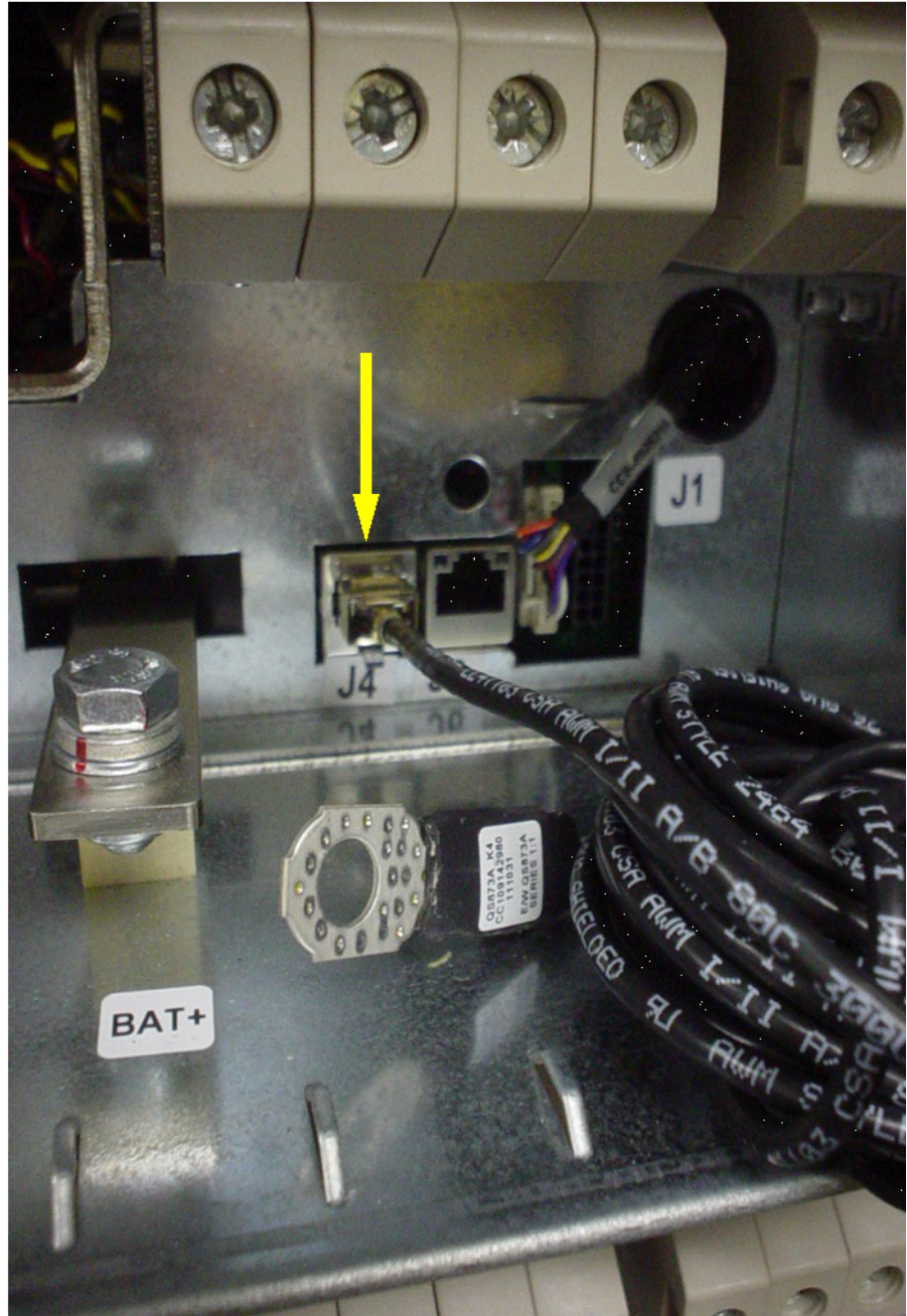
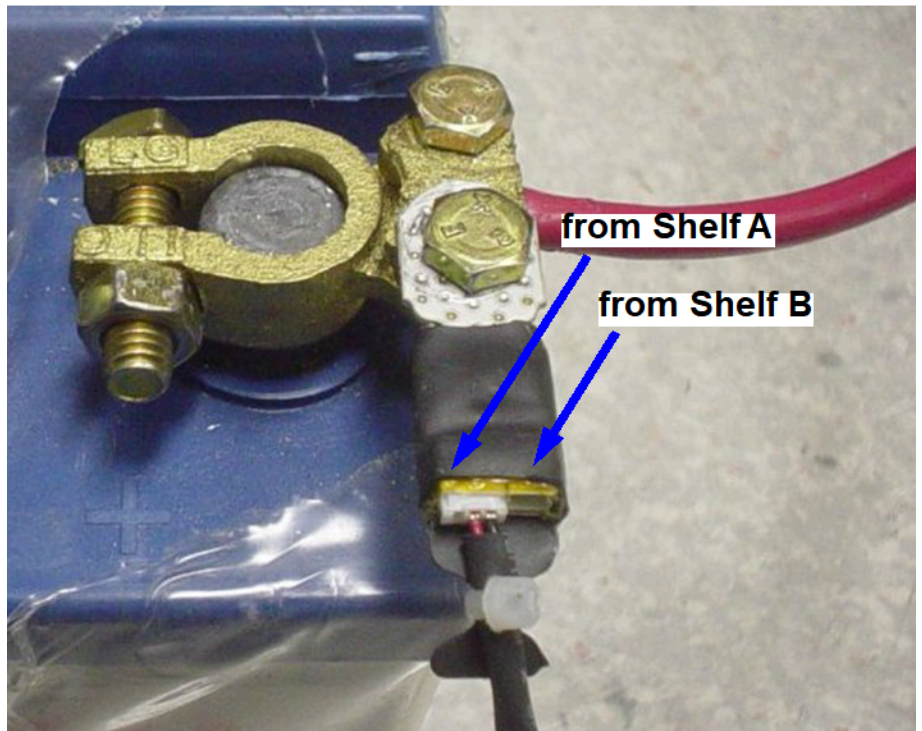
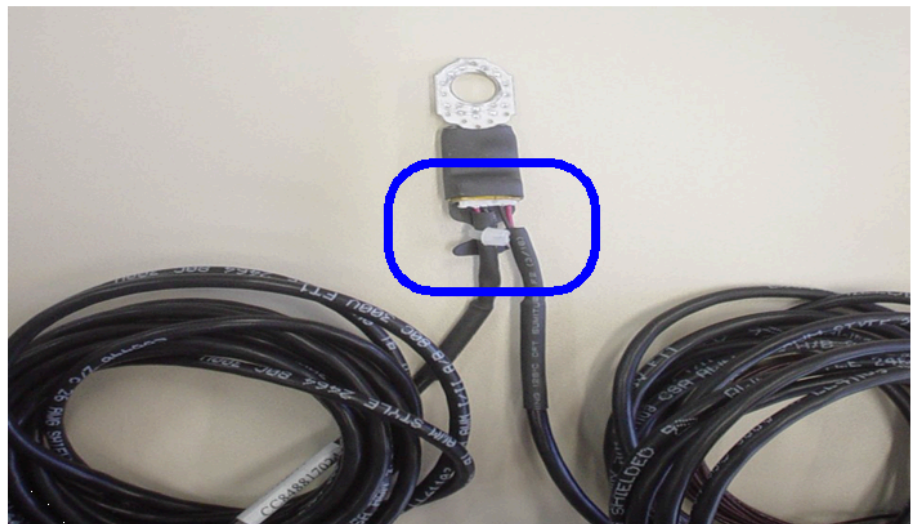


Figure 142: Thermal probe connection J4



**Figure 143: Thermal probe connection to the battery**

- 3) Step 3: Secure the temperature probe cover to the probe (see [Figure 53](#)).
- 4) Step 4: In case of an secondary shelf B secure the temperatur probe additionally beside the temperature probe of the primary shelf A (see [Figure 53](#) and [Figure 54](#)).



**Figure 144: Thermal probe connection for Shelf A and B**

## 7.15.2 Alarm Outputs

The alarm outputs connect from J1 on the rear of the shelf to the customer office alarm system. There are six form-C alarm output relays rated at 60Vdc, 0.5A each. The factory default alarm descriptions are shown in the table below.

**Table 5: Alarm Outputs (PIN Description)**

PIN	Description
1	Door Open Alarm
2	Auxiliary Major Alarm
3	VBUS (PTC protected)
4	Power Major Alarm Return
5	Power Minor Alarm Return
6	Battery On Discharge Alarm Return
7	Rectifier Fail Alarm Return
8	AC Fail Alarm
9	SPD Fail (Surge Protection Fail)
10	Air Conditioner Fail
11	Unassigned
12	Power Major Alarm
13	Power Minor Alarm
14	Battery On Discharge Alarm
15	Rectifier Fail Alarm
16	AC Fail Alarm

### 7.15.3 UACD Power Box Part Numbers

Table 6 provides an overview of the equipment (and corresponding part numbers) used in UACD-A and UACD-B

**Table 6: Equipment in UACD (Lineage Power)**

Qty.	Name	Part number	Remark
UACD-A			
1	UACD-A for (Primary Shelf)	S30122-H7744-X	Power supply and distribution cabinet
3	EP3000TE	S30122-X8009-X22	Rectifier Module (Order Separately)
4	CBI Circuit Breaker 40A Single Pole	S30122-X8011-X8	Overload protection for system

Qty.	Name	Part number	Remark
1	CBI Circuit Breaker 200A Four Pole with aux sense	S30122-X8011-X9	Overload protection for battery
1	ALIN Cable 2.5m	S30122-X8011-X12	Communication alarm cable
1	Controller	S30122-X8011-X4	For spare parts order
1	Thermal Probe	S30122-X8011-X5	Thermal Probe Cable to controller
1	Thermal Probe Cable	S30122-X8011-X6	Thermal Probe Cable to controller - 1m
UACD-B			
1	UACD-B for (Secondary Shelf)	S30122-H7745-X	Power supply and distribution cabinet
3	EP3000TE	S30122-X8009-X22	Rectifier Module (Order Separately)
4	CBI Circuit Breaker 40A Single Pole	S30122-X8011-X8	Overload protection for system
1	CBI Circuit Breaker 200A Four Pole with aux sense	S30122-X8011-X9	Overload protection for battery

#### 7.15.4 AC/DC Connection - Cabinet variants

7.15.4.1 AC/DC Connection UACD with AP3700

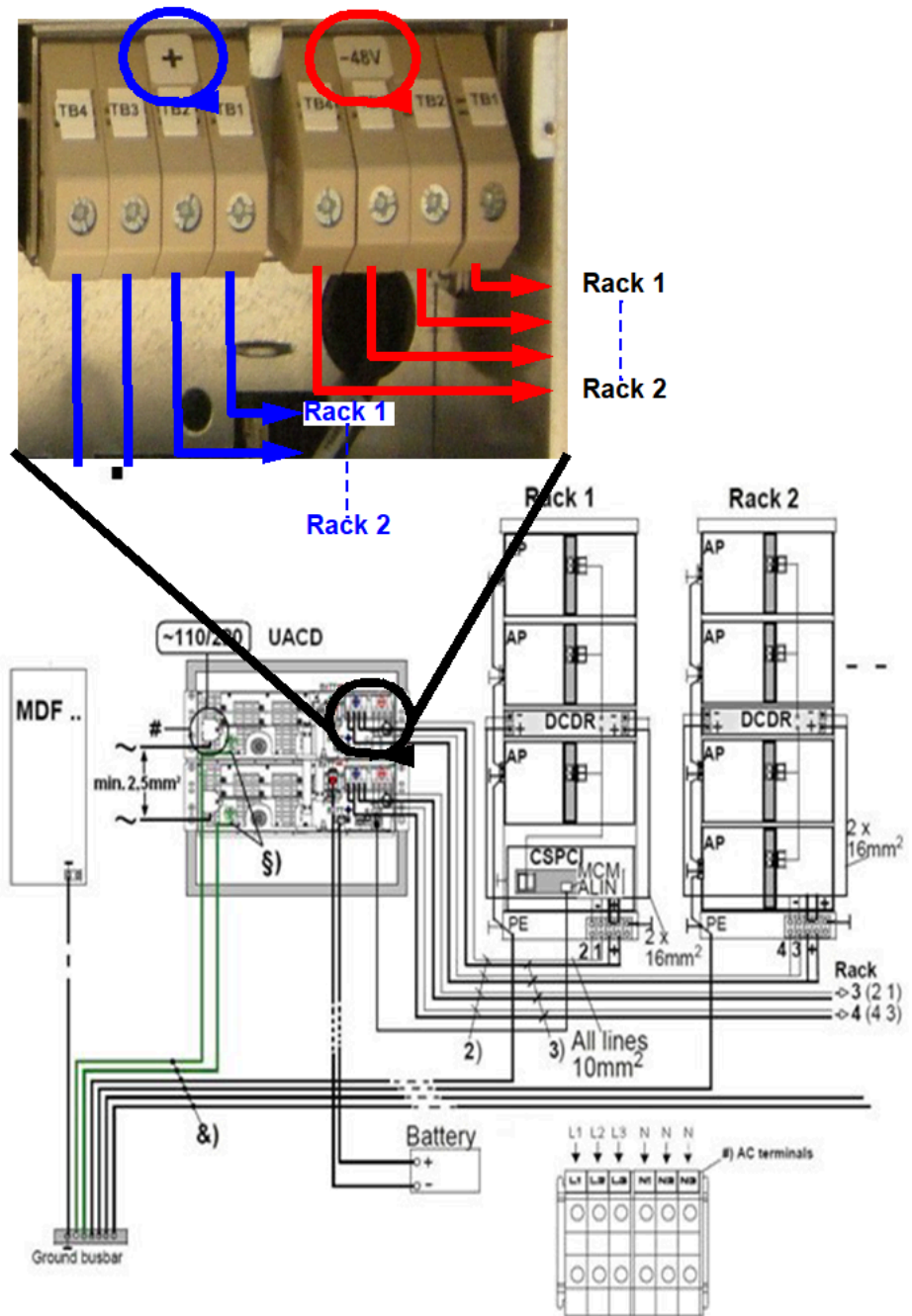


Figure 145: AC/DC Connection UACD with AP3700

7.15.4.2 AC/DC Connection UACD with UPR/LTUW"

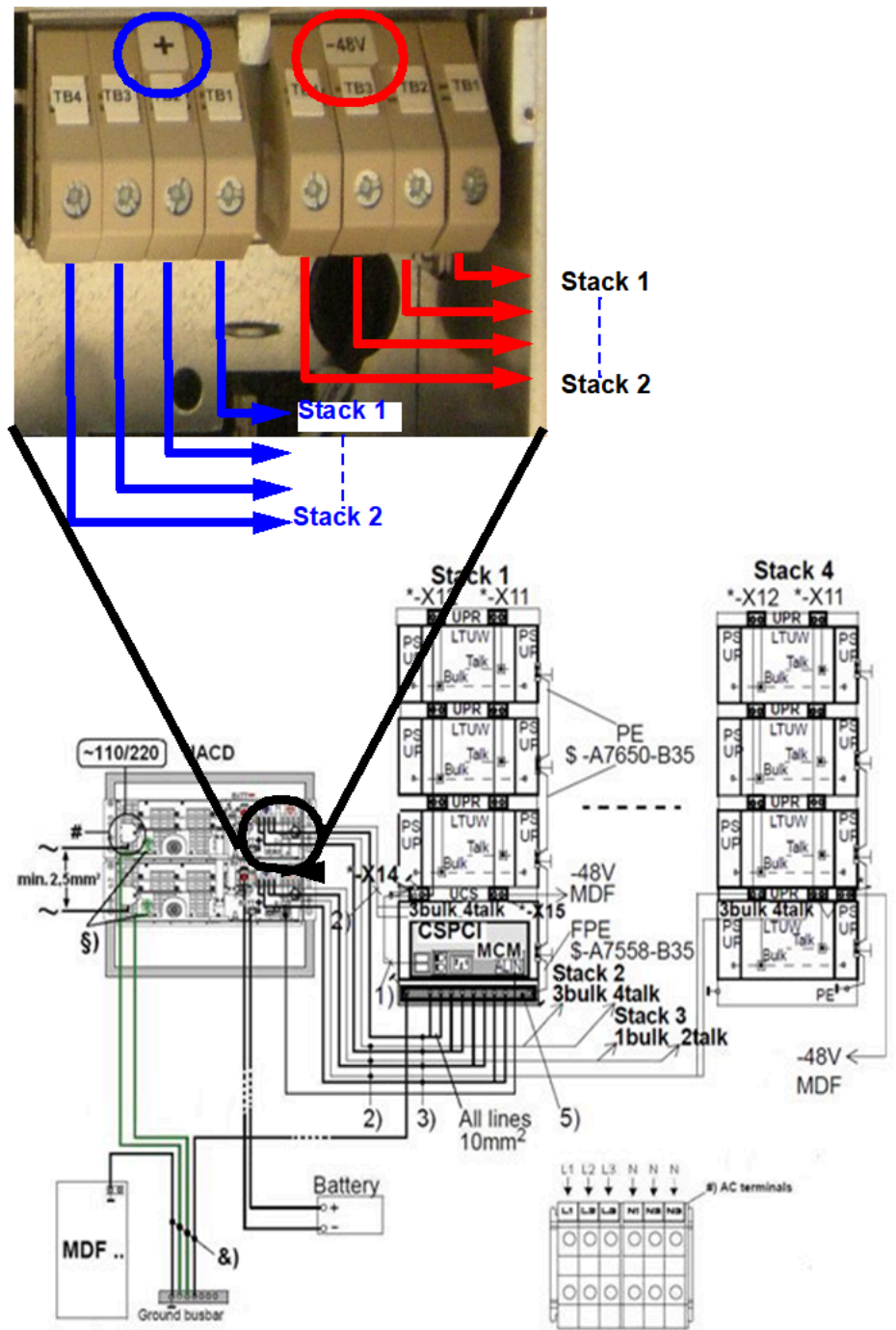


Figure 146: AC/DC Connection UACD with UPR/LTUW"

7.15.4.3 UACD Cable list

Table 7 refers to Figure 55 and Figure 56.

**Table 7: Cable table for UACD (Lineage Power)**

Qty.	Name	Part number	Remark (from --> to)
1)	DC cable	S30805-H5298-X14 C39195-A7944-B38	Stack 1, UCS, -X14 --> CSPCI, Mate-N-Lok connector
2)	- Cable	C39195-A7944-B16/17	UACD --> Stack 1.... 4
3)	+ Cable	C39195-A7556-B540	UACD --> Stack 1, 0-V busbar
4)	ALIN cable	S30122-X8011-X12	UACD, base controller --> CSPCI, MCM, ALIN
5)	0-V busbar	C39165-A7080-D1	Mounted in stack 1 on the roll plate
Remark			
&)	PE cross-section min. 10mm <sup>2</sup> , 6 AWG (AWG = American Wire Gage)		
Â§)	PE line is connected		
#)	AC Terminals		
*)	S30805-H5298-X...		
\$)	C39195-A...		

### 7.15.5 Mains Connection Variants for UACD

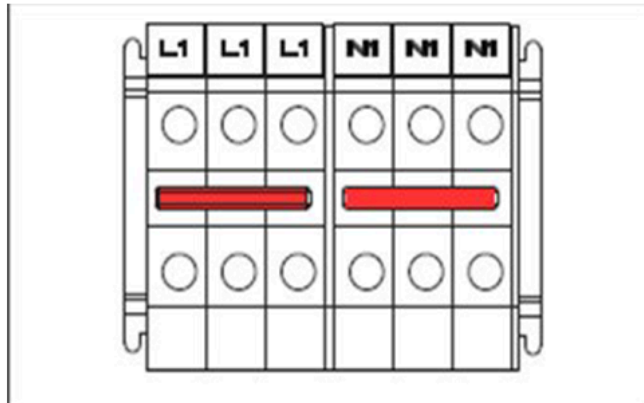
The following country-specific mains connection variants are available for UACD:

#### Install AC input wiring

AC input terminations are located behind the cover on the rear of the shelf. AC inputs can range between 90 to 290 VAC. Jumpers are provided to configure the options. The jumpers are factory configured for option 1 (Single/Dual phase). The three options are shown in the following figures.

#### AC input options

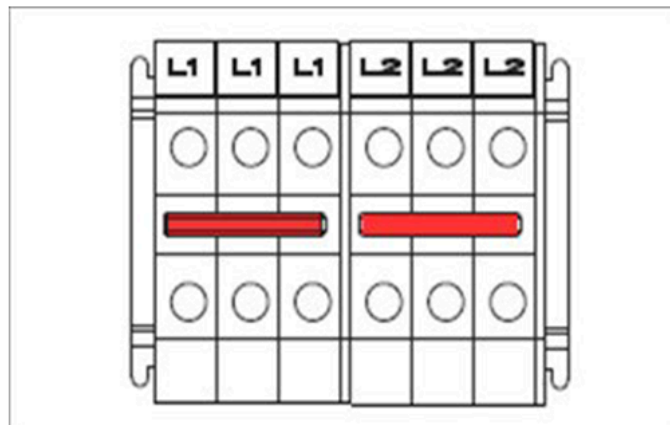
Single phase (factory default); L1, L2, L3 jumpered and N1, N2, N3 jumpered.



Typical 3 wire input; phase to neutral with PE ground. Three rectifiers are fed from one input.

**Figure 147: AC input option 1 (Single phase)**

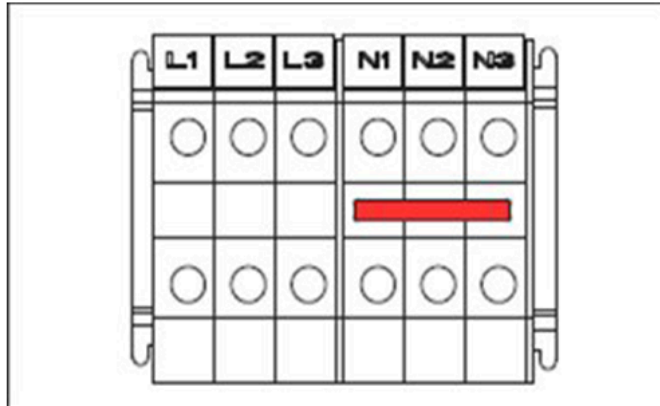
Dual phase (factory default); L1, L2, L3 jumpered and N1, N2, N3 jumpered.



Typical 3 wire input; phase to neutral with PE ground. Three rectifiers are fed from one

**Figure 148: AC input option 1 (Dual phase)**

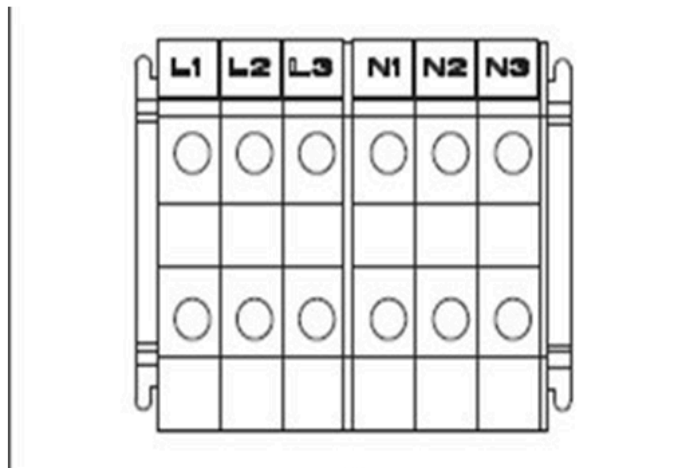
Three phase star connection; L1, L2, L3 individual feeds. N1, N2, N3 jumpered.



Typical 5 wire input; 3 phase inputs (L1, L2, L3), one neutral and one PE ground. Three rectifiers are fed from three phases with one neutral feed.

**Figure 149: AC input option 2 (Three phase star connection)**

Three phase triangle connection; No jumpers.

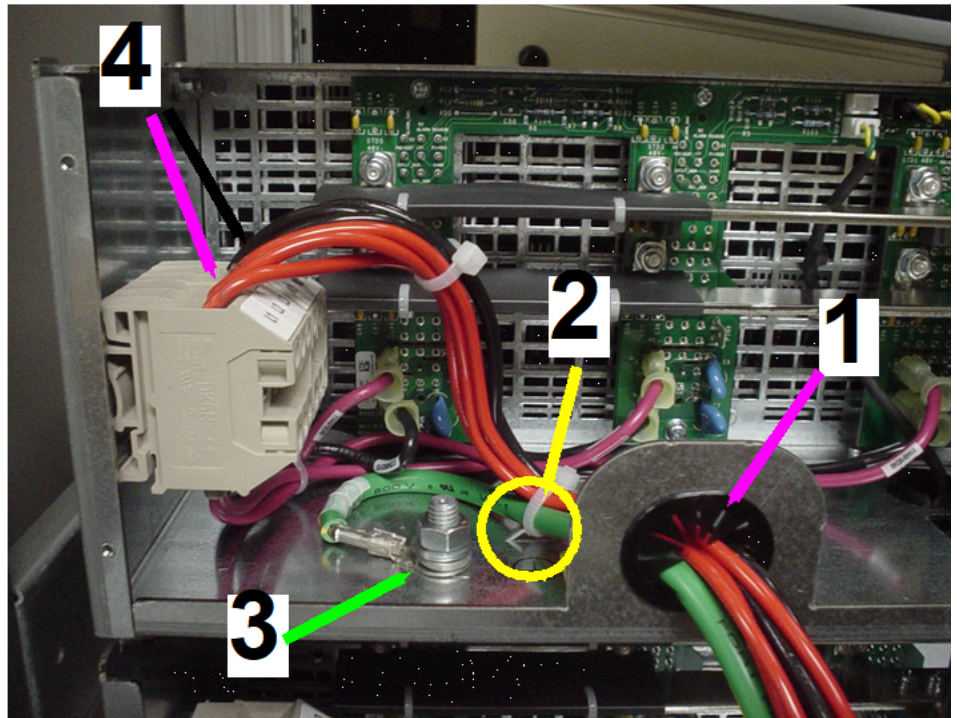


Typical 7 wire input; 3 phase inputs (L1, L2, L3) and 3 neutral inputs (N1, N2, N3) and one PE ground. Three rectifiers are individually fed from three circuits.

**Figure 150: AC input option 2 (Three phase star connection)**

Step 1: Remove the 6 screws and cover from the rear of the shelf (see [Figure](#) ).

Step 2: Route the ac wires through the shelf grommet (1). Bundle the wires together and secure the bundle with a zip tie behind the grommet. Use a second zip tie to strain relieve the bundle to the shelf tie point (2).



**Figure 151: Routing AC wires**

Step 3: Secure the Ground (PE) wire (green-yellow), see (3) on [Figure](#) . Torque to 20 -lbs.

Step 4: Strip insulation from the ac input wires, insert and secure wires to the terminal blocks, see (3) on [Figure](#). Torque terminal screws to 20 in - lbs.

### 7.15.6 Connecting a Battery to the UACD

One set of battery connections are located on each shelf. Two battery strings can be connected to a two shelf system; one on each shelf. The battery connections accept up to a 1/0 AWG cable. Shelves share battery power in a two shelf system. A 200 Amp battery circuit breaker is located on the front of each shelf.

---

**NOTICE:** Verify correct battery cable polarity before landing battery cables.

---

Step 1: Remove the M8 bolts and connect battery cables to the battery bus bars as shown in [Figure](#). Torque connections to 60 - inch lbs.

Step 2: Dress and strain relieve battery cables in a downward direction and route the wires through the outlet on backside (see [Figure](#)).

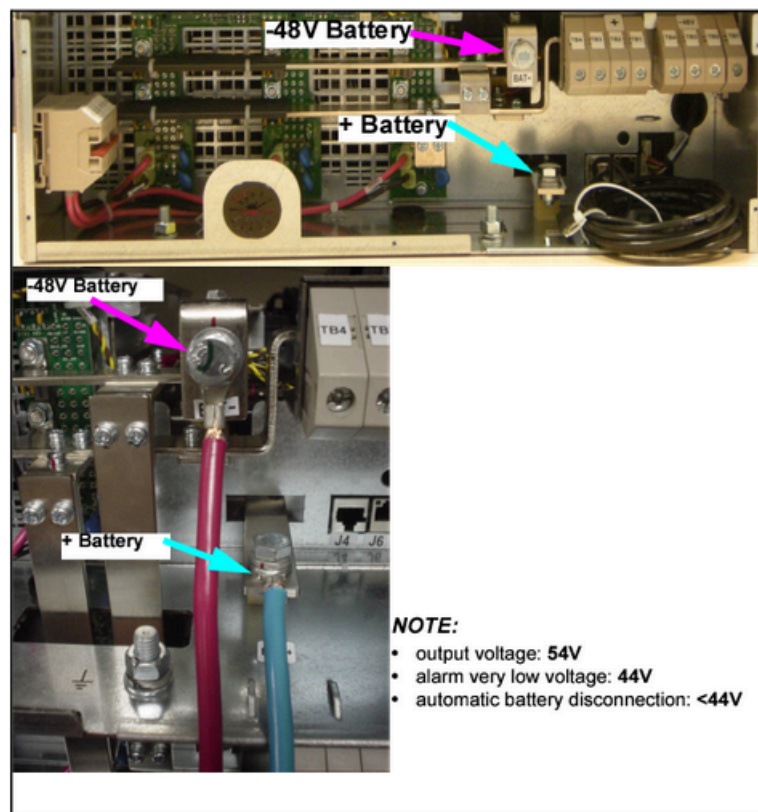


Figure 152: Battery connection to the bus bars

### 7.15.7 UACD Additional informations

For additional information about the UACD, it may be checked the UACD installation and users guide document, provided by the UACD manufacturer, which comes together with the product, inside the package. This document contains some clarifications about the below topics:

- Product overview
- Safety statements
- Warning and precautions
- Installation
- Alarm descriptions
- User interfaces (LAN and USB)



**WARNING:** The user interfaces may be used for monitoring the UACD status and alarms. The UACD controller (Pulsar controller) parameters are factory configured, according to Unify's systems requirements. Therefore, for Unify system's usage, the original UACD Pulsar controller parameters must not be changed.

## 7.16 UACD (GE) 30-Inch Installation (for upgrade installations only)

Table 8 provides an overview of the equipment (and corresponding part numbers) used for UACD (GE) 30-inch installation.

**Table 8: Equipment for UACD (GE) 30-Inch Installation**

Qty.	Name	Part number	Remark
1	Kit used on the front side	C39165-A7080-B177-1	
1	Kit used on the back side	C39165-A7080-B176-1	
1	Connection Cable used on the back side	C39195-A7944-B59-1	
1	Communication Cable used on the back side	C39195-A7944-B60-1	



**Figure 153: One Shelf 30"**

---

**NOTICE:** The pictures used in this chapter showed the Connection Bars without the specified surface treatment (tin plated).

---

General Remarks:

- All components and surface treatment must be RoHS compliant.
- Front Panel with protective foil must be packed with bubble wrap and the fasteners should be put in a plastic bag. Each kit consists of one Front Panel and fasteners according to the specific Kit Part Number (e.g: B176 or B177).

### 7.16.1 Kit C39165-A7080-B177-1 “ Components to be used on the Front side

No.:	Qty.	Part number Remark
1	1	Front Panel Stainless Steel sheet metal according to AISI 304 or AISI 430 (polished grain 240) - Thickness 1,5 mm according to the supplier
2	8	Torx Screw M4x8mm - stainless steel or 2A;
2A	8	Alternative Screw M4x8mm steel Screw head according to the supplier;
3	4	Torx Screw M6x12mm - stainless steel or 3A; (3A. Alternative Screw M6x12mm steel Screw head according to the supplier);
3A	4	Alternative Screw M6x12mm steel Screw head according to the supplier
4	4	Clip Nut M6 steel (Example: C39121-Z7001-C22)

Kit C39165-A7080-B177-1 Components to be used on the Front side

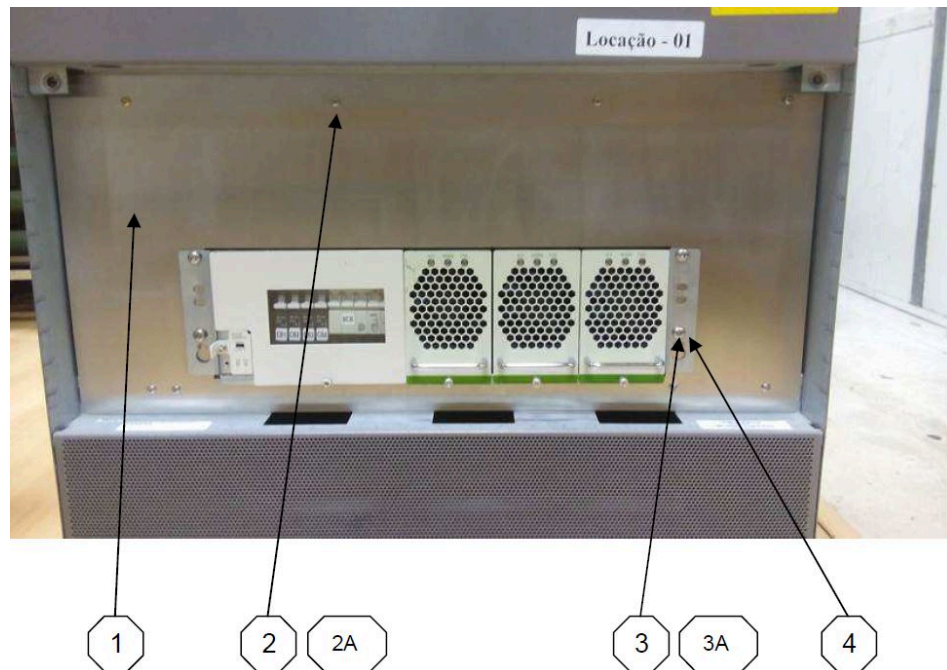
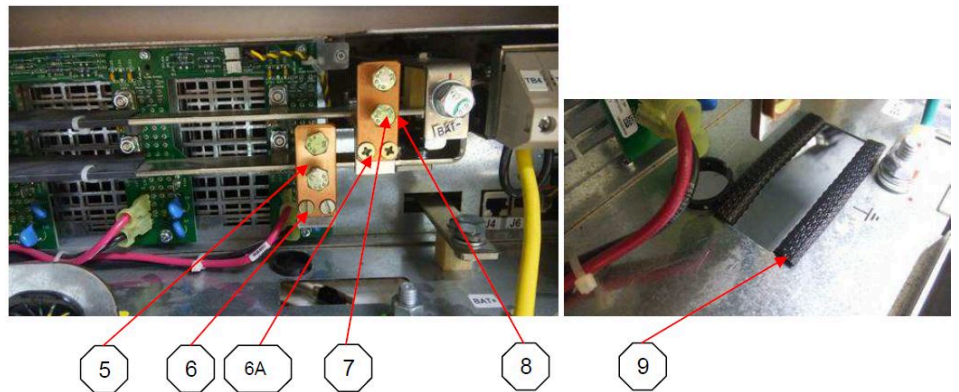


Figure 154: Kit C39165-A7080-B177-1 Components to be used on the Front side

### 7.16.2 Kit C39165-A7080-B176-1 “ Components to be used on the Back side

No.:	Qty.	Part number Remark
5	2	Connection Bar Copper Sheet according to DIN1751-E-CU57F20-3 (Tin plated) - Thickness 3,0 mm
6	4	Flat Head Screw M4x8mm steel
6A	4	6A. Flat Head Screw M4x8mm steel type according to the supplier)
7	4	Hexagon Screw M6x12mm steel
8	4	Locking contact washer M6 steel
9	1	Locking contact washer M6 steel

Kit C39165-A7080-B176-1 Components to be used on the Back side



**Figure 155: Kit C39165-A7080-B176-1 Components to be used on the Back side**

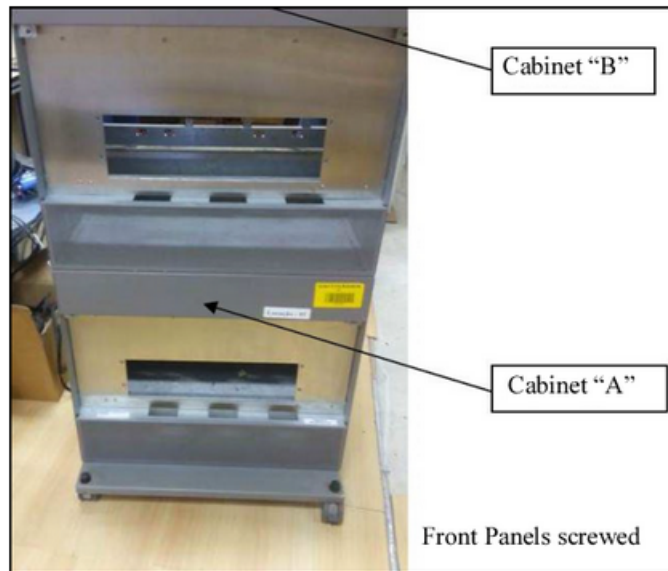
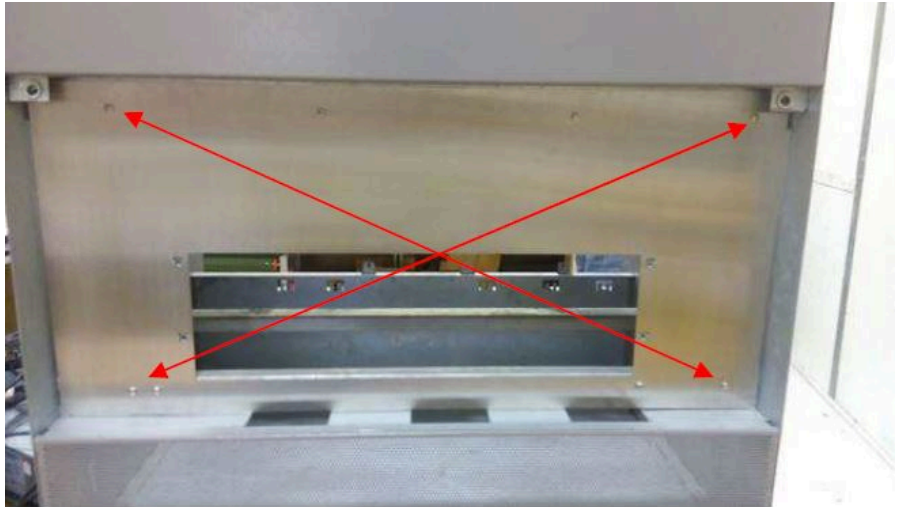
### 7.16.3 Mounting Guideline for Two Shelves 30 Inch Step by step

- 1) Remove the protective foil of the Front Panel C39165-A7080-C177-1. Put the Clip Nuts M6 (4x) on the square holes of the front panel and put it on the front side of the shelf 30" according to the picture below.

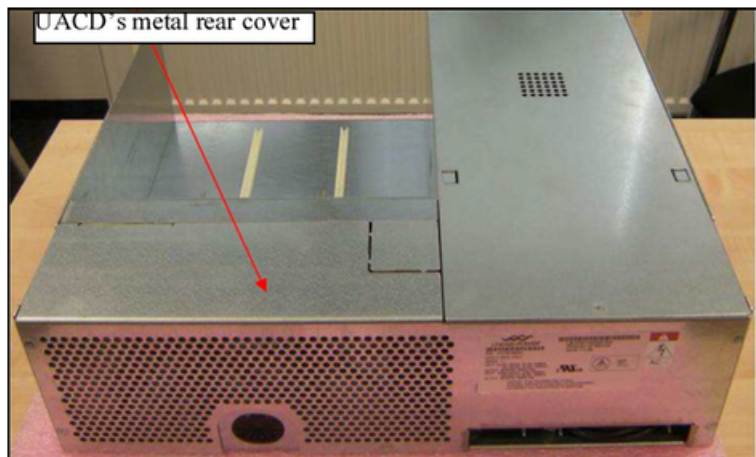


- 2) Screw the Front Panel C39165-A7080-C177-1 using the screws M4x8mm (8x) by tightening them diagonally (in red on the next picture), to divide the

gap between the holes of the panel in relation to the threads of the shelf 30".



- 3) Remove the UACD metal rear cover.



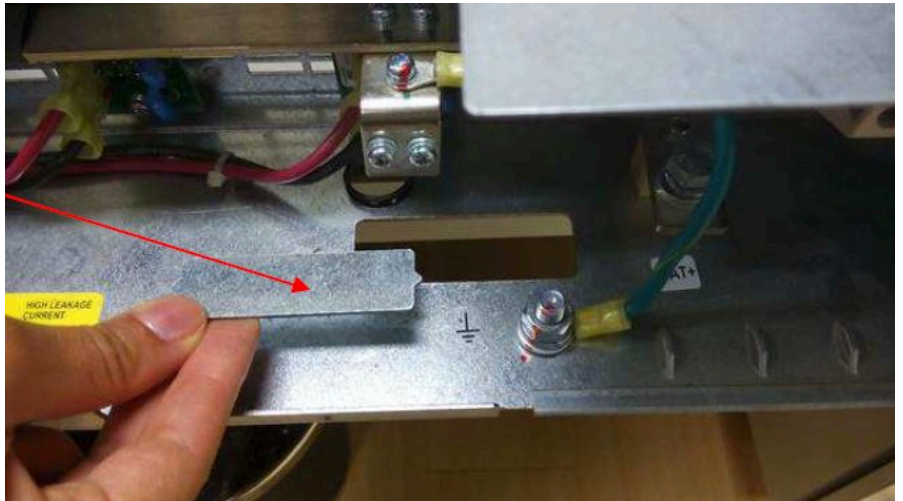
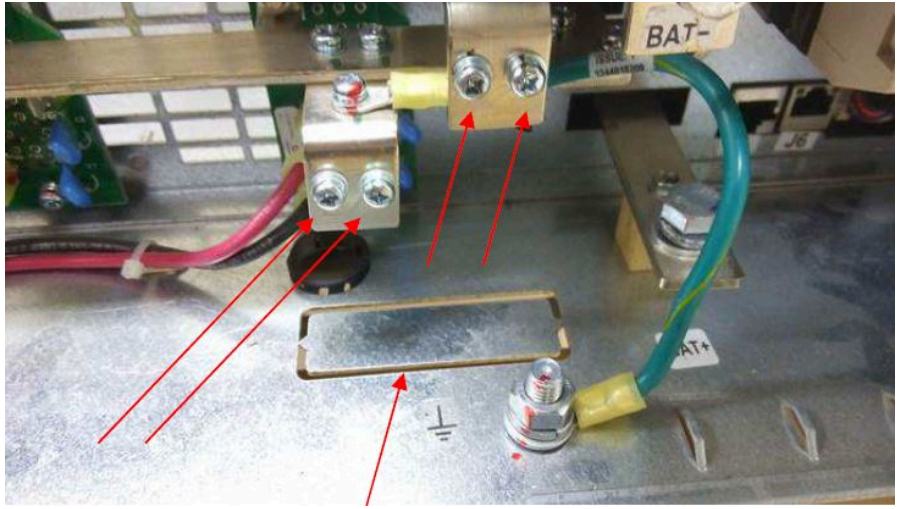
## Connecting to the Mains and Power Supply

- 4) Insert partially the UACDs on the front side of the shelves - without rectifiers.

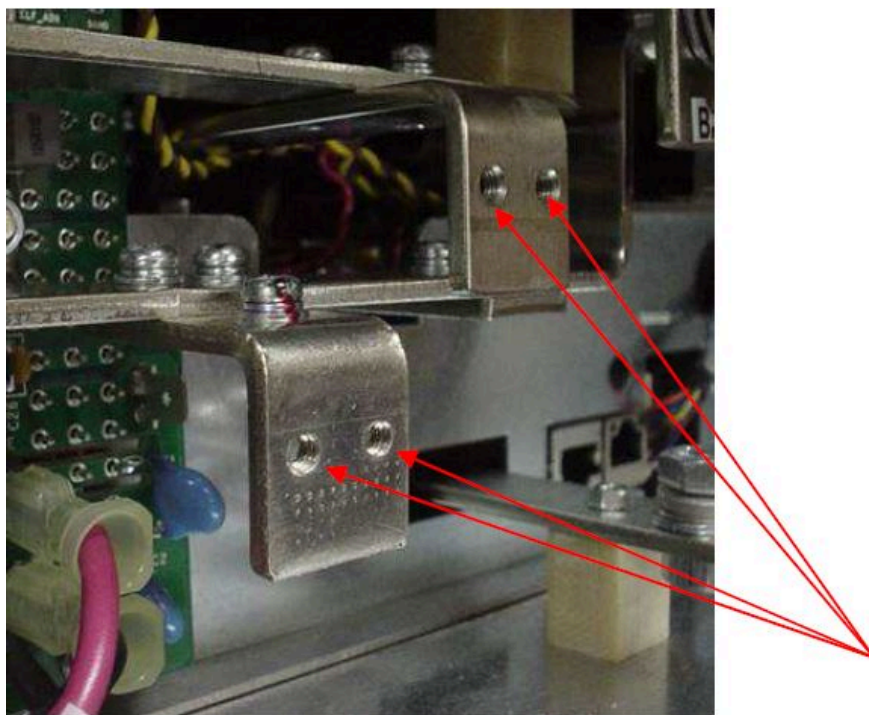


Space required for handling the cables easily on the back side!

- 5) On the back side of the UACD, remove the original screws (4x) of the internal connection bars and also the piece of sheet metal according to the pictures below.



## Connecting to the Mains and Power Supply



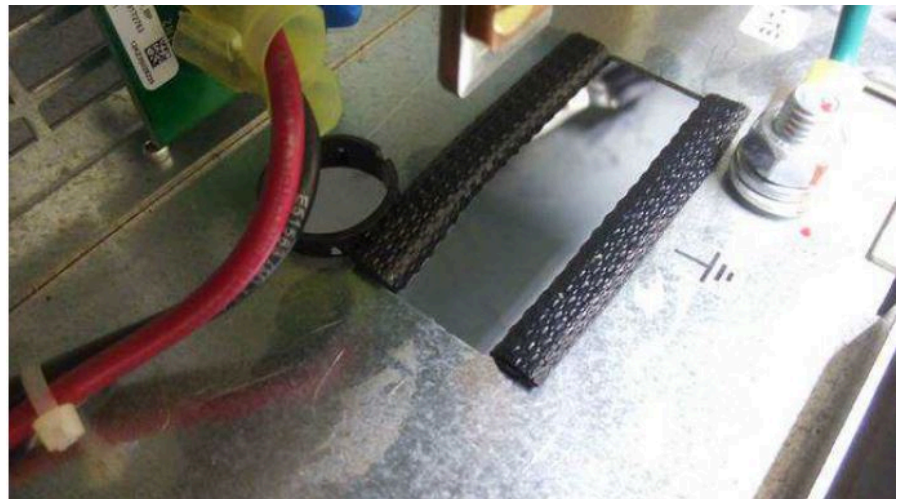
- 6) Fix the connection bars C176 (2x) on the original internal bars of the UACD using the Flat Head Screw M4x8mm (4x).

### Connection bars C176 (2x)



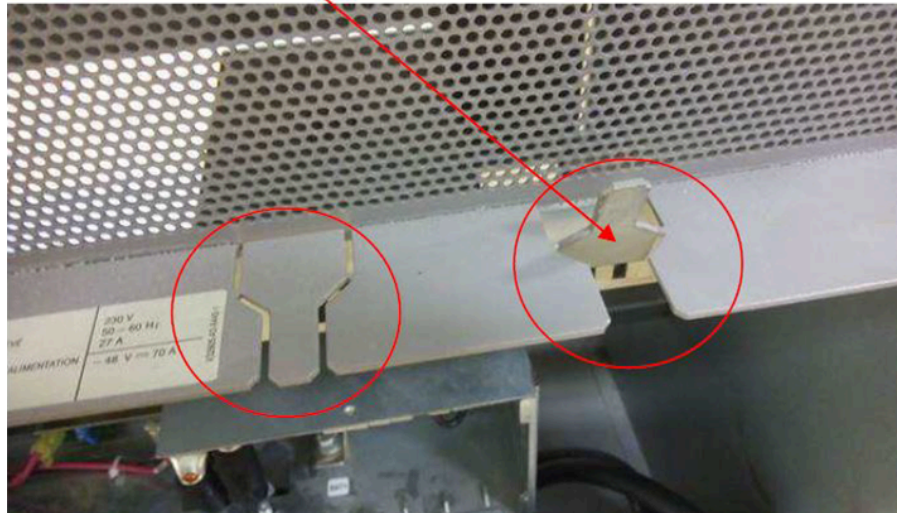
## Connecting to the Mains and Power Supply

- 7) Cut the protection edge C39123-Z4-C24 (1x) in two pieces (+70mm each) and fix them on the corners of the rectangular hole to protect the connection cables, according to the pictures below.



- 8) Remove the UACDs pieces of sheet metal (2x), according to the appropriated connection cables B59 runs.

UACDs pieces of sheet metal (2x)



## Connecting to the Mains and Power Supply

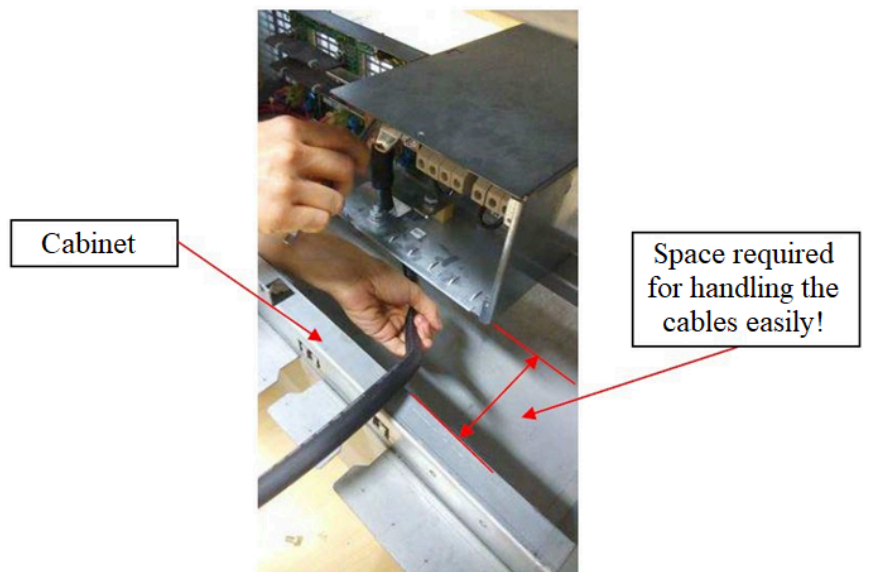
- 9) Position one at a time or both Connection Cables C39195-A7944-B59 (2x) on UACDs.



- 10) Fix the terminals of the two Connection Cables C39195-A7944-B59 (2x) on the connection bars C176 (2x) using the Hexagon Screw M6x12mm and the Locking contact washer M6 (4x). Note: To facilitate assembling and

## Connecting to the Mains and Power Supply

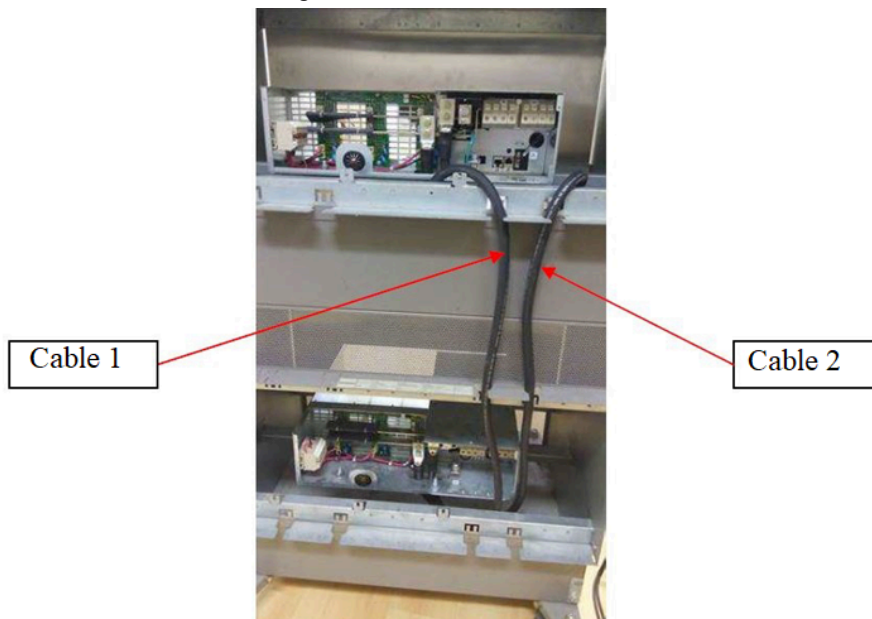
positioning of the terminals, hold the cables with one hand and with the other use the suitable tool to tighten the hexagonal screws.



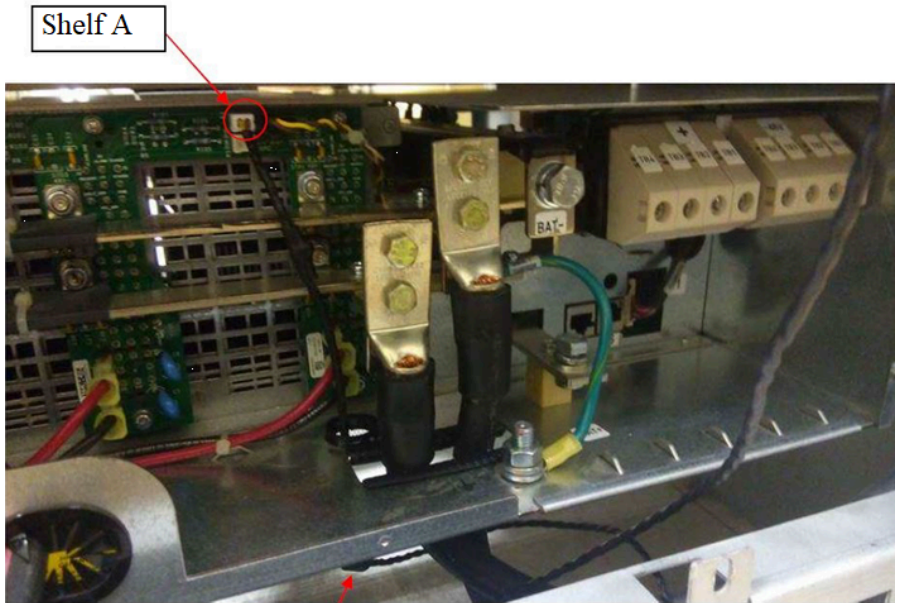
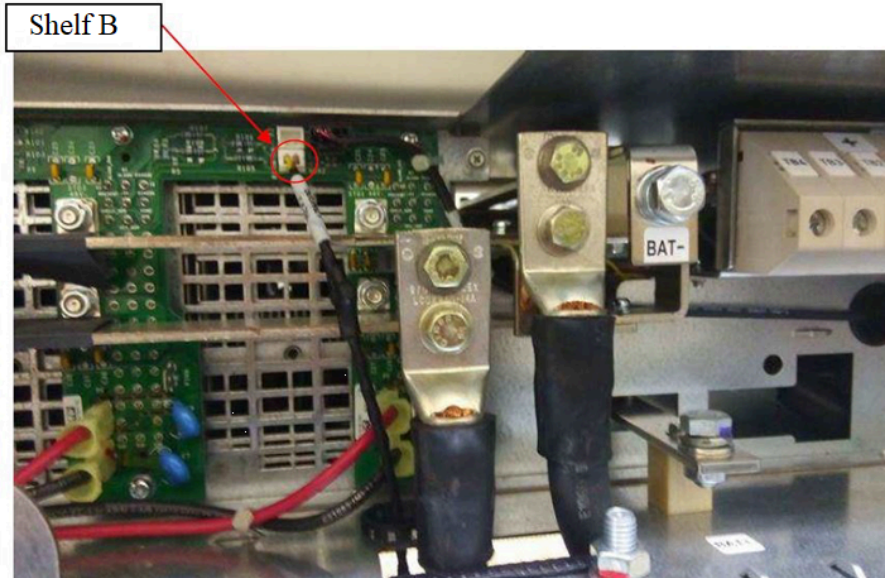
- 11) Repeat the same steps (from 3 to 9) for the other Shelf.
- 12) Finished the fixation of the terminals and the positioning of the Connection cables, check if the electrical connection of the cables is correct.

## Connecting to the Mains and Power Supply

Suggestion: to avoid cables inversion, use a cable strip or a label to identify one of these cables during installation.

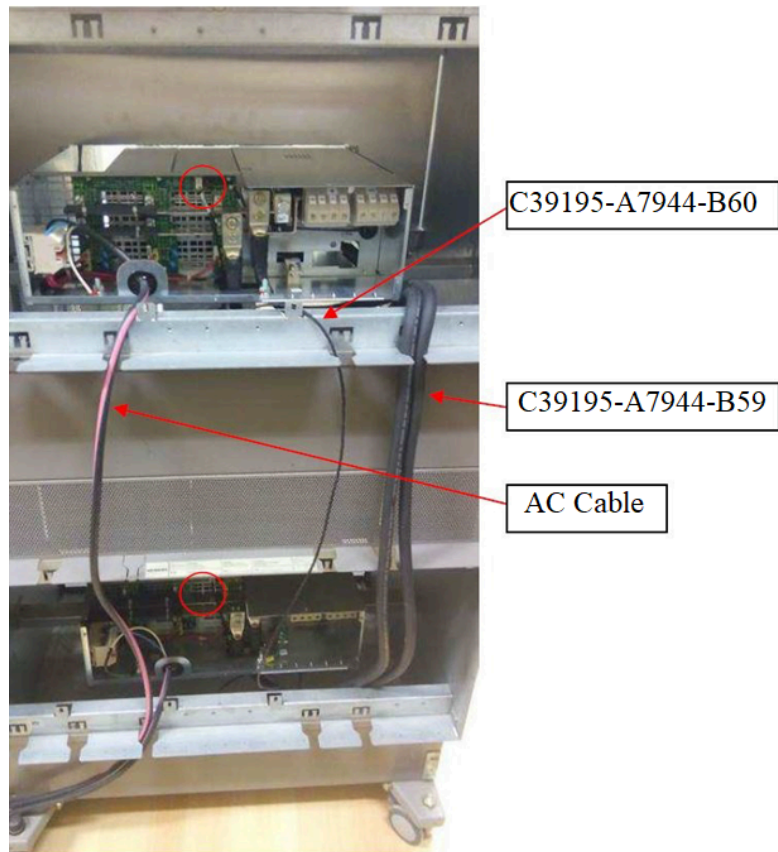


- 13) Connect the Communication Cable C39195-A7944-B60 (1x) according to the pictures below. Pay attention on the correct slots of the UACDs Shelves and the positioning of the ferrite.



The ferrite is below the sheet metal.

## Connecting to the Mains and Power Supply

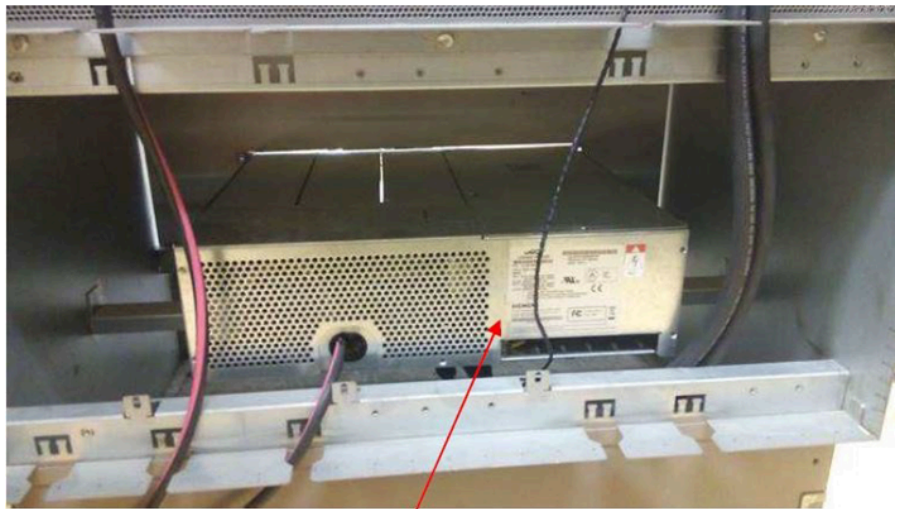


Remark: The path/passage of the cables between the Shelves is the choice of each installer!

- 14) Put the metal rear covers of the both UACDs.



Metal rear cover  
UACD B



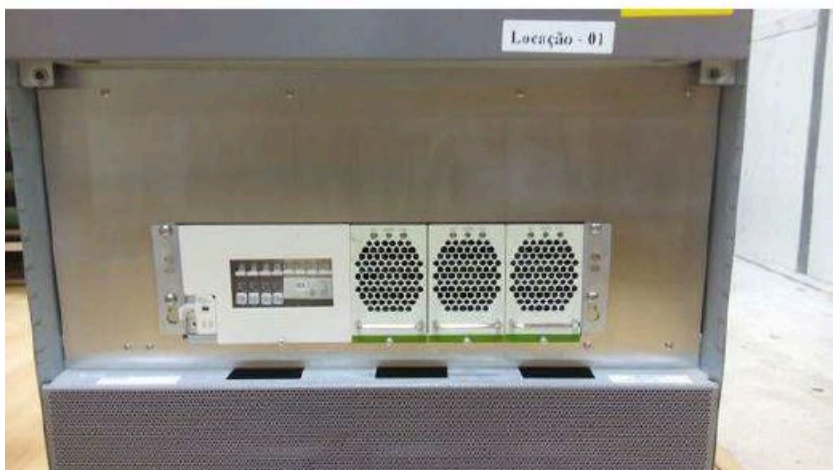
Metal rear cover  
UACD A



- 15) Insert totally both UACDs on the Shelves and fix them using the Screws M6x12mm (4x).



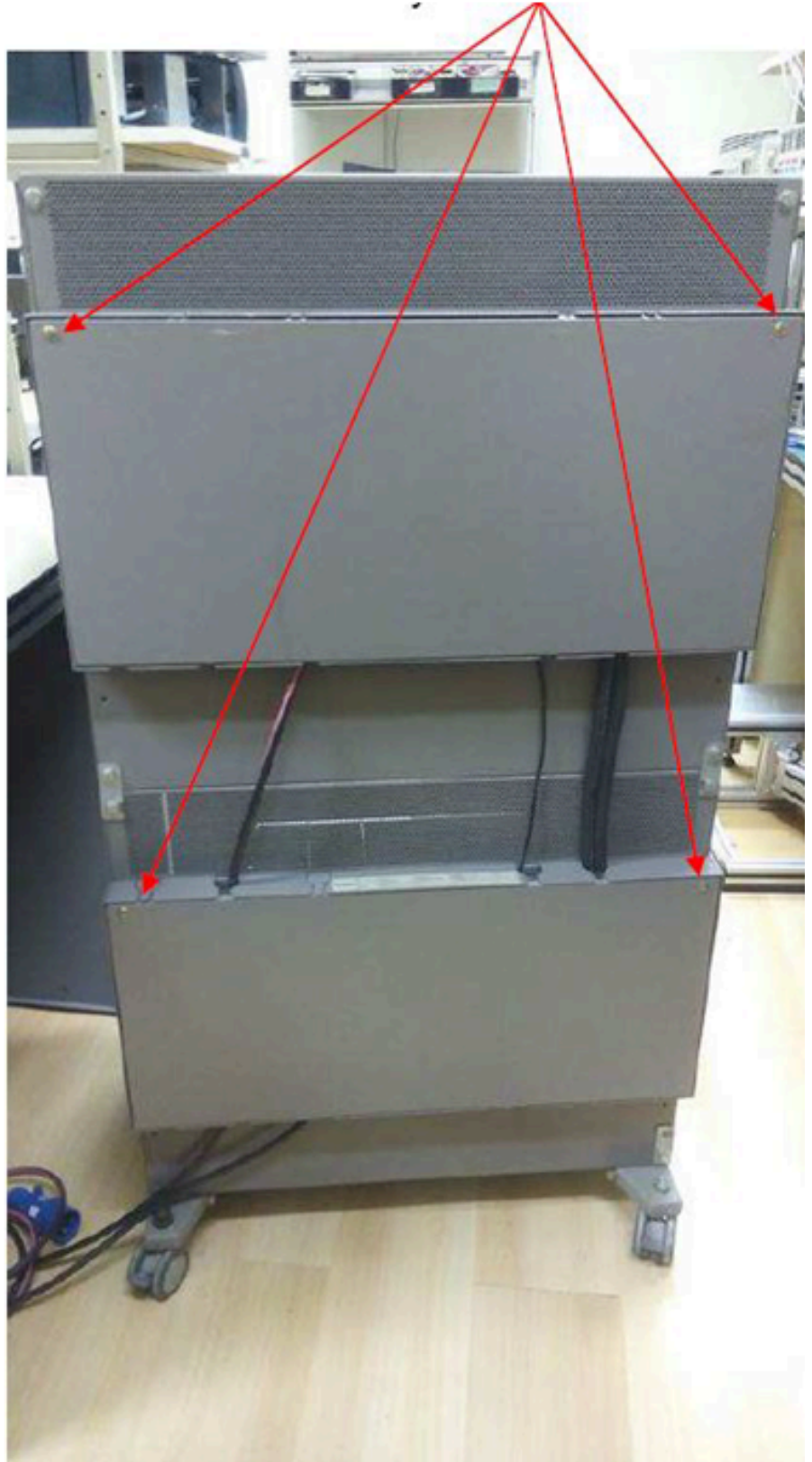
- 16) Insert the rectifiers on both UACDs.



## Connecting to the Mains and Power Supply

- 17) Put the Shelf's back covers and fix them by the bolts.

Bolts



## Connecting to the Mains and Power Supply



- 18) Put the Shelf's frontal covers, fix them by the bolts and check if everything is OK.

## Connecting to the Mains and Power Supply



## 7.17 UACD (PSR930/PSR930E) 19-Inch Installation

The UACD power box (PSR930/PSR930E) is a AC/DC power box for use in 19-inch cabinets.

It consists of the following 19-inch mounting units:

- Base cabinet PSR930 (with basic controller board A901)
- Expansion cabinet PSR930E

---

### IMPORTANT:

- The UACD power box (PSR930/PSR930E) may only be installed in a separate, closed 19" cabinet. This cabinet must ensure mechanical and electrical protection and may only be serviced by authorized service personnel.
  - All PSR930 lines (in the 19" cabinet) must be secured with an appropriate cord grip (e.g. cable tie).
- 

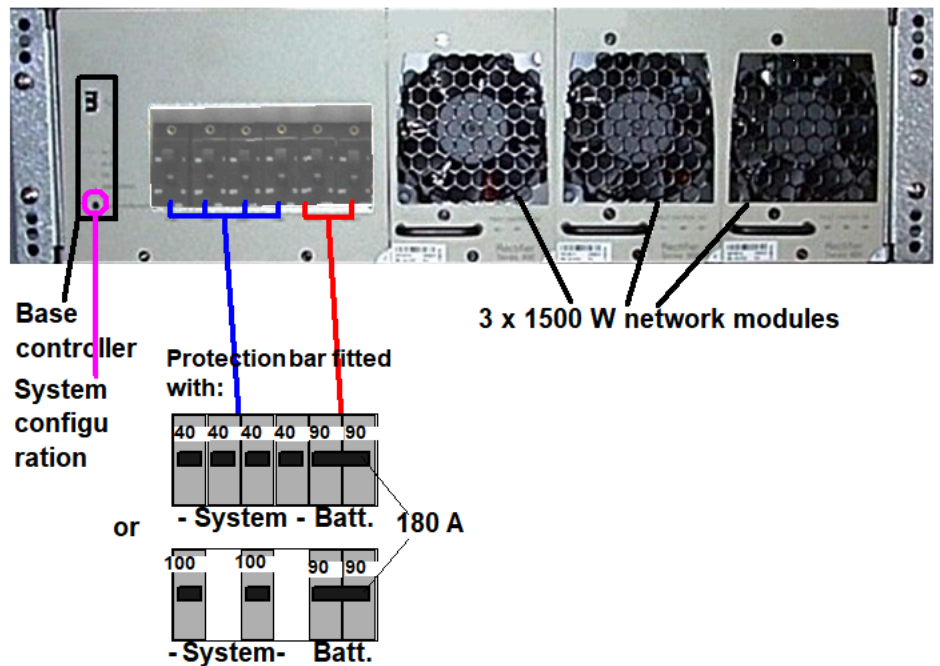


Figure 156: UACD base cabinet PSR930 (front view)

The UACD expansion cabinet PSR930E has the same structure as the base cabinet minus the base controller.

---

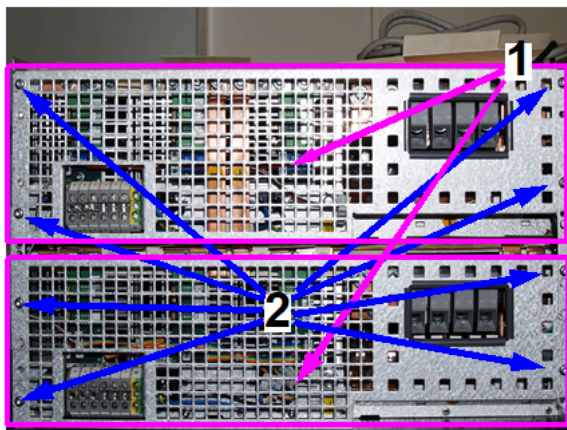
### IMPORTANT:

- Before starting up the power, ensure that all network modules on the front are securely screwed into the shelf to guarantee a secure contact.
- If you need to replace a network module or change the number of network modules, you must hold down the "System configuration" button for at least 3s on the controller (see Figure ) after the replacement/expansion to ensure that

## Connecting to the Mains and Power Supply

the new network module can be reassigned to the alarm system.

To connect the power supply cables to an UACD, you must first remove the rear covers.



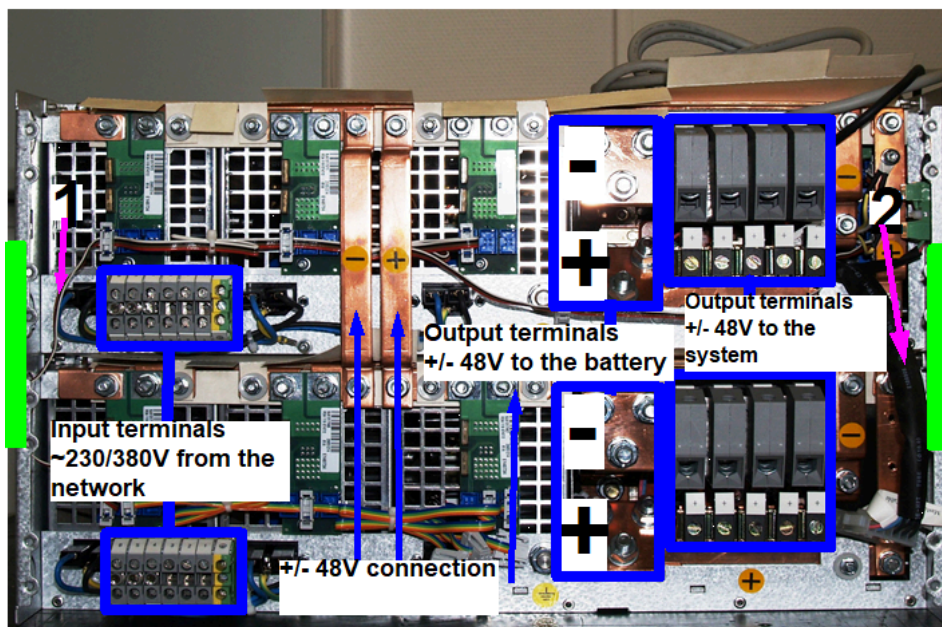
First of all, remove the cover panel (1) at the back of the UACD by removing the lateral fixing screws (2).

Figure 157: Removing the UACD Cover

Figure shows the UACD base and expansion cabinet PSR930/PSR930E.

### IMPORTANT:

The base and expansion cabinets are physically connected left and right at the rear by a metal bracket (indicated in green in Figure ) (see also the Service Manual).



If a base and expansion cabinet are used, the +/-48V are connected as shown in this image.

Figure 158: UACD power box PSR930/PSR930E (back view)

To establish communication with the expansion cabinet, first connect the base cabinet's relevant bus cable (1) to the expansion cabinet. Then plug the base cabinet's contactor control monitoring cable (2) into the expansion cabinet (see also the Service Manual).

---

**IMPORTANT:** To connect the +/-48V to the system at the UACD's output terminals (see [Figure](#) ), you must first remove the blue cable connector at one end of the cable supplied and strip the wire. This cable is connected directly to the terminals.

---

### 7.17.1 UACD Power Box Part Numbers (PSR930/PSR930E)

[Table 11](#) provides an overview of the equipment (and corresponding part numbers) used in PSR930/PSR930E.

**Table 9: Equipment in PSR930/PSR930E**

Qty.	Name	Part number	Remark
1	PSR930 (1)	EZY:S30050-G6383-X100	Power supply and distribution cabinet
3	Rec/mod. GR90 1500W	EZY:S30050-K6383-X	Rectifier (network module), order separately
1	Base Controller	EZY:S30050-Q6383-X100	for spare parts order
4	Circuit Breaker 40A	V39118-Z7180-A11	Overload protection for system or
2	Circuit Breaker 100A	V39118-Z7180-A12	Overload protection for system
1	Circuit Breaker 180A	V39118-Z7180-A14 (2x90A)	Overload protection for the battery
1	PSR930E (2)	EZY:S30050-G6383-E100	Power supply and distribution cabinet, expansion
3	Rec/mod. 48V/1500W	EZY:S30050-K6383-X	Rectifier (network module), order separately
4	Circuit Breaker 40A	V39118-Z7180-A11	Overload protection for system or
2	Circuit Breaker 100A	V39118-Z7180-A12	Overload protection for system
1	Circuit Breaker 180A	V39118-Z7180-A14 (2x90A)	Overload protection for the battery

7.17.2 AC/DC Connection with UACD (PSR930/PSR930E) in 19" Cabinet with AP3700

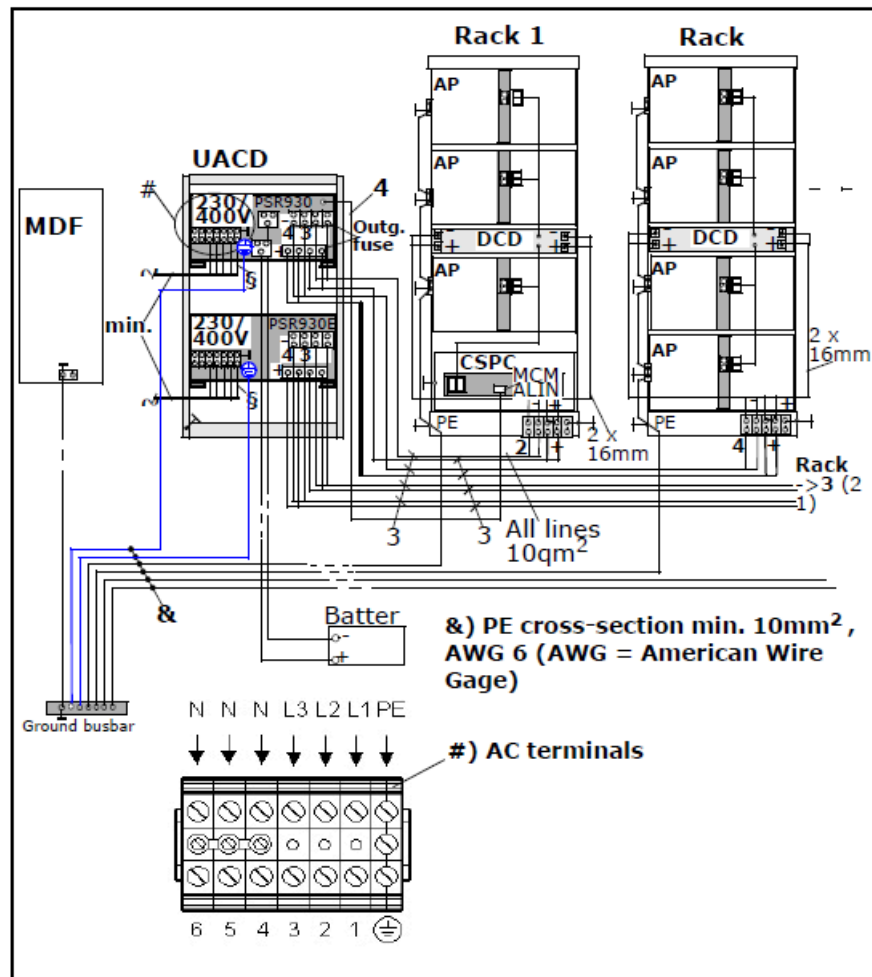
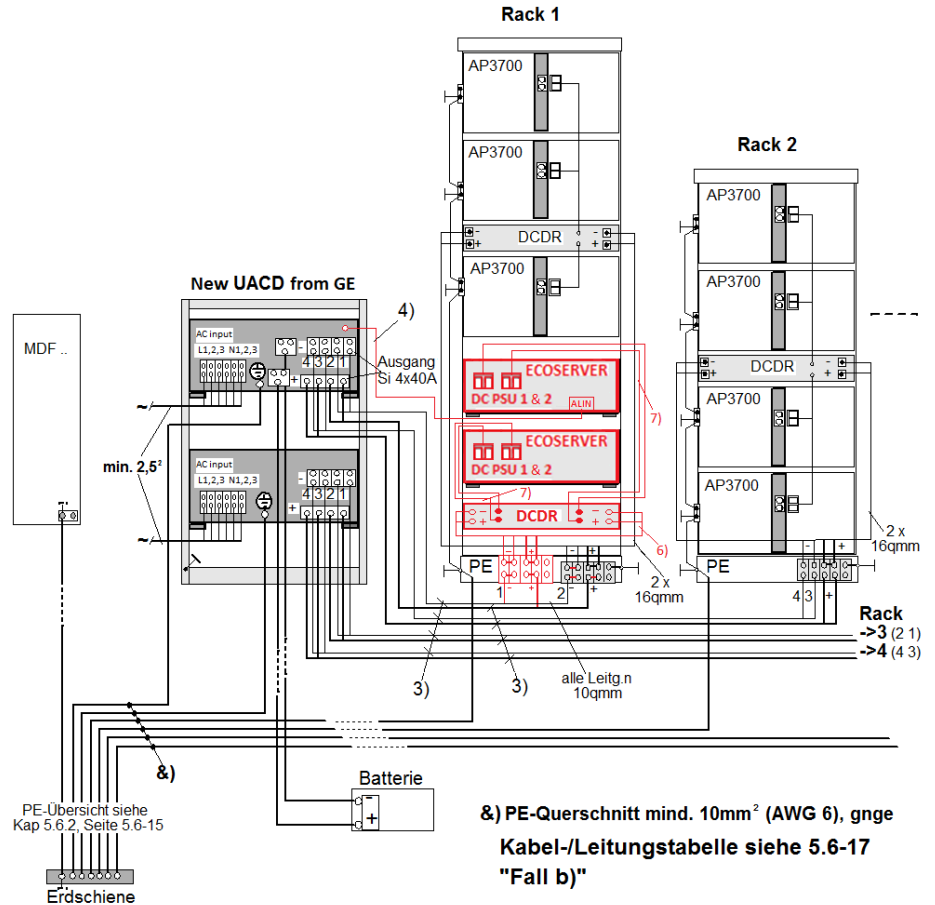


Figure 159: AC/DC Connection with UACD (PSR930/PSR930E) in 19" Cabinet with AP3700

### 7.17.3 AC/DC Connection - SAPP Boxes (from HP4 V2.0) with EcoServer and UACD from GE in 19" Cabinet



**Figure 160: AC/DC Connection - SAPP Boxes (from HP4 V2.0) with NEW in 19" Cabinet**

Nr. Sachnummer / No code no.	Bezeichnung / design	Bemerkung / remark von / from --> nach / to
3) C39195- A7556-B540	+ Cable	From UACD --> to DC terminal block connection
4) S30122-X8011- X12	ALIN-cable 5m long	From UACD Basiscontroll. --> to EcoServer ALIN, DB9 connector.
6) C39195-Z70- C91	CABLE 16MM2 BLACK	From DCDR --> to DC terminal block connection
7) C39195- A7944-B56	Cable +/- 48V	From DCDR --> to EcoServer DC PSU

7.17.4 AC/DC Connection with UACD (PSR930/PSR930E) in 19" Cabinet with UPR/LTUW

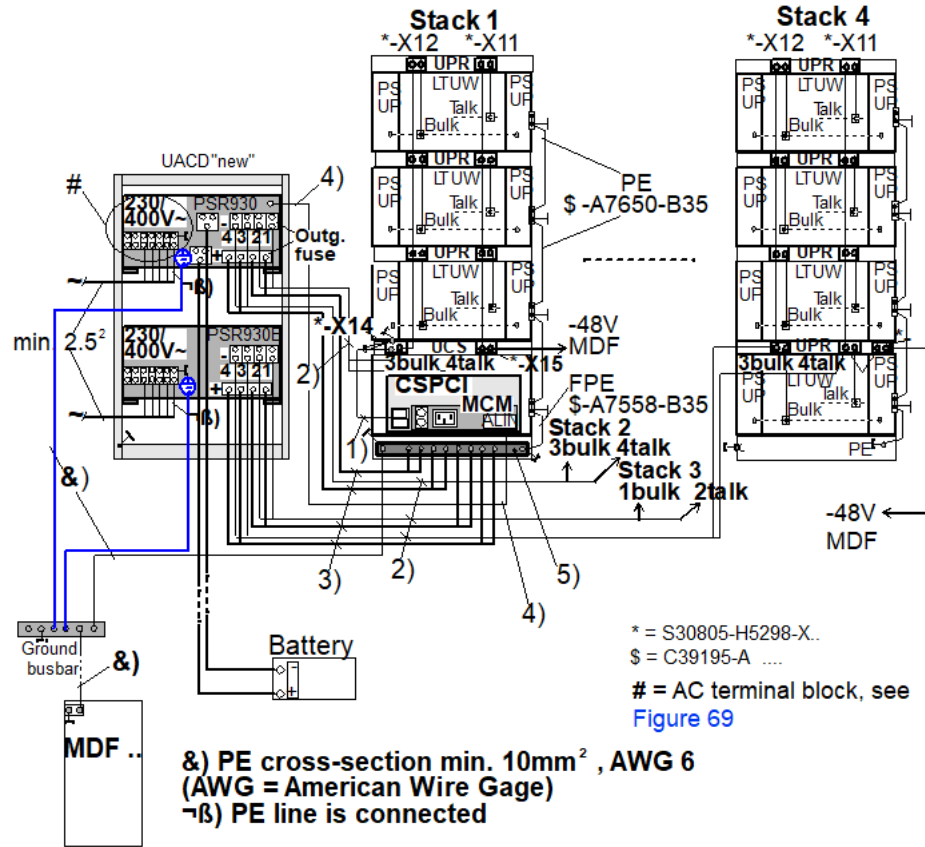


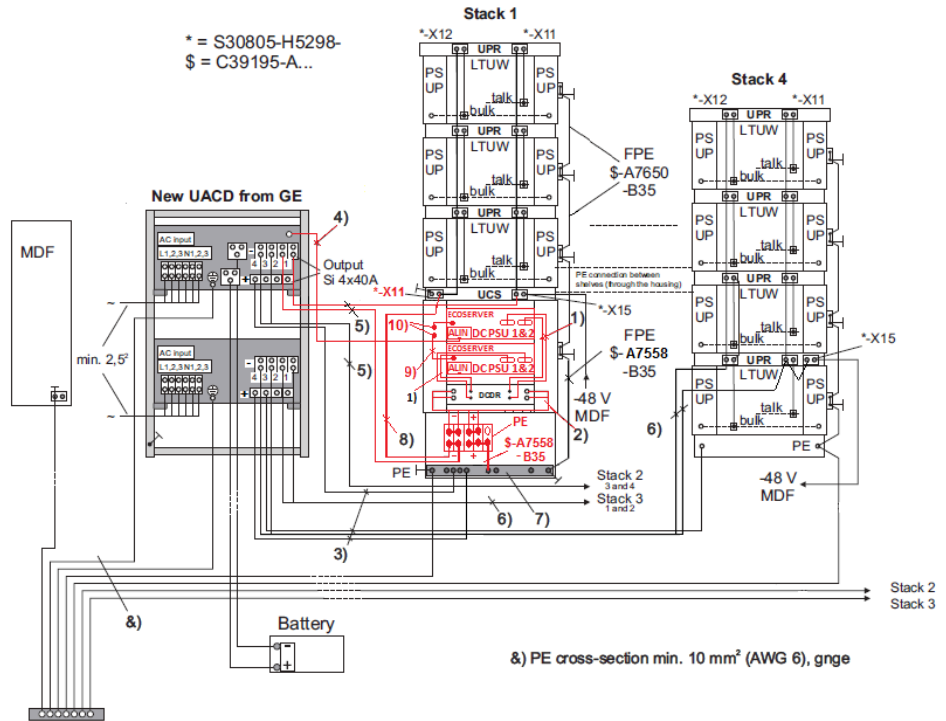
Figure 161: AC/DC connection with UACD (PSR930/PSR930E) in 30" cabinet with UPR/LTUW

Table 13 refers to Figure 69 and Figure 71.

Table 10: Cable table for UACD (PSR930/930E)

Qty.	Name	Part number	Remark (from --> to)
1)	DC cable	S30805-H5298-X14	Stack 1, UCS, -X14 --> CSPACE, C39195-A7944-B38 Mate-N-Lok connector
2)	- Cable	C39195-A7944-B16/17	UACD, PSR930/930E --> Stack 1.... 4
3)	+ Cable	C39195-A7556-B540	UACD, PSR930/930E --> Stack 1, 0-V busbar
4)	ALIN cable	Cable length supplied: 2.5 m	UACD, PSR930, base controller --> CSPACE, MCM, ALIN
5)	0-V busbar	C39165-A7080-D1	Mounted in stack 1 on the roll plate

### 7.17.5 Stacking construction (up to HP4 V2.0) with UACD NEW in 19" Cabinet with UPR/LTUW periph.



Nr. Sachnummer / No code no.	Bezeichnung / design	Bemerkung / remark von / from --> nach / to
1) C39195-A7944-B56	DC Cable 2.5m	From DCDR --> to DC PSU of the EcoServer
2) C39195-Z70-C91	CABLE 16MM2 BLACK	From DCDR --> to terminal block
3) C39195-A7556-B540	+ Cable	From UACD, DC terminal block --> to 0V-Schiene
4) S30122-X8011-X12	New ALIN Cable	From GE UACD --> to EcoServer ALIN, DB9 connector..
5) C39195-A7944-B16	Cable	From UACD --> to Stack 1-2
6) C39195-A7944-B17	Cable	From UACD --> to Stack 3-4
7) C39165-A7080-D1	0V-bar	Will be mounted in Stack 1 on the roll plate
8) C39195-A7954-B33	DC-CONNECT. CABLE	From UCS i to DC terminal block (remove the clear tap)
9) C39195-A7514-B80	Cable 80 cm	Cable for EcoServer equipotential bonding

## Connecting to the Mains and Power Supply

Nr. Sachnummer / No code no.	Bezeichnung / design	Bemerkung / remark von / from --> nach / to
10) H60118-B4012- Z1	Screw	Screw for Ecoserver equipotential bonding cable fixation

### 7.17.6 Mains Connection Variants for UACD (PSR930/PSR930E)

The following country-specific mains connection variants are available for UACD (PSR930/930E):

#### 7.17.6.1 Installing a Three-Phase Network

With a three-phase network, the 3 neutral wires are connected with a contact jumper (1). Connect the corresponding power line as illustrated below.

Figure shows the mains connection to the UACD for a three-phase network.

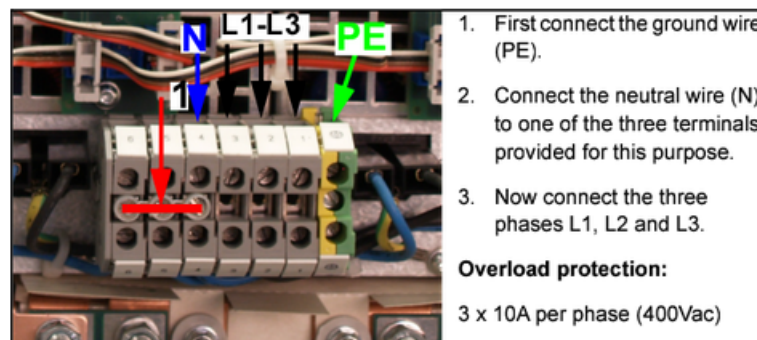


Figure 162: Sample connection for a three-phase network (PSR930/PSR930E)

#### 7.17.6.2 Installing a Single-Phase Network

The jumper (1) - if still installed - must be removed for a single-phase connection. Connect the corresponding power line as illustrated below.

Figure shows the mains connection to the UACD for a one-phase network.

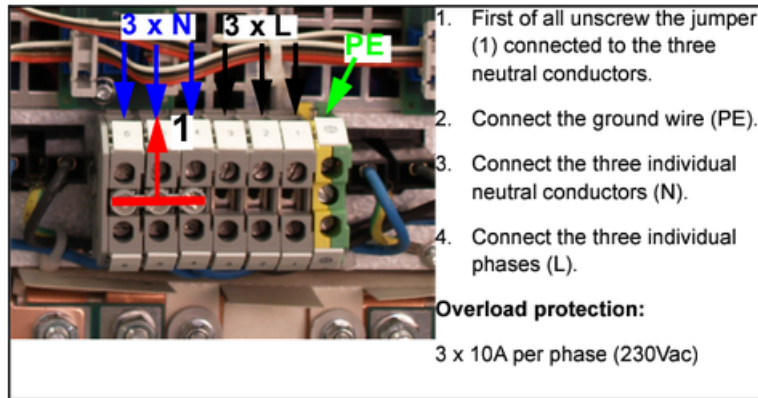


Figure 163: Installing a single-phase network (PSR930/PSR930E)

### 7.17.6.3 Installing a Two-Phase Network

The jumper (1) - if still installed - must be removed for a two-phase connection. Connect the corresponding power line as illustrated below.

Figure shows the mains connection to the UACD for a two-phase network.

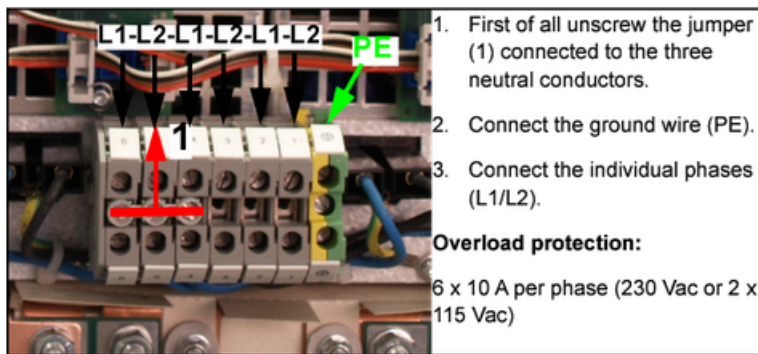


Figure 164: Installing a two-phase network (PSR930/PSR930E)

### 7.17.6.4 Installing a Mains Delta Connection

The jumper (1) - if still installed - must be removed for a mains delta connection. Connect the corresponding power line as illustrated below.

Figure 75 shows the mains connection to the UACD for a mains delta connection.

**Connecting to the Mains and Power Supply**  
 UACD (with BAMX1 and BAMX2) 30-Inch Installation

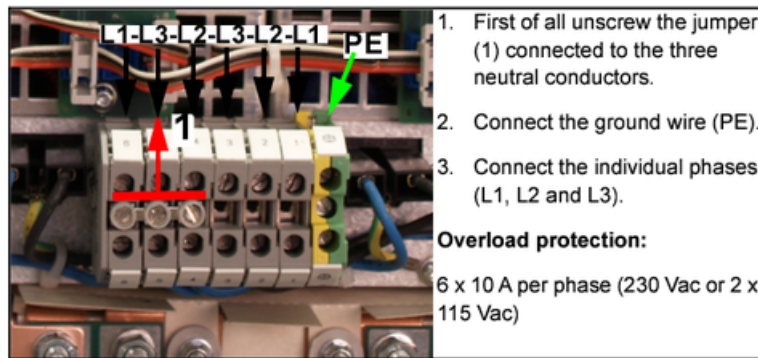


Figure 165: Connecting a mains delta connection (PSR930/PSR930E)

**7.17.7 Connecting a Battery to the UACD (PSR930/PSR930E)**

Proceed as indicated in the following diagram to connect a battery to the UACD.

Figure shows how to connect a battery to the UACD (PSR930/PSR930E).

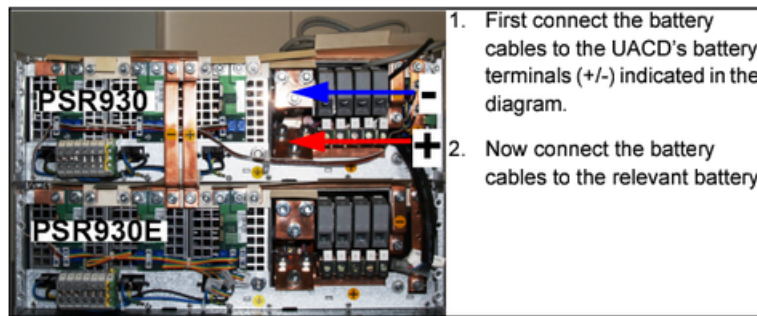


Figure 166: Connecting a battery to the UACD (PSR930/PSR930E)

---

**IMPORTANT:** The UACD's temperature sensor must be disconnected if it is not in use or if the battery is located at a distance of over 20m from the power box.

---

**7.18 UACD (with BAMX1 and BAMX2) 30-Inch Installation**

Figure 77 shows the UDCD DC-to-DC power box.

---

**IMPORTANT:** The EBCCB is not used in the U.S.

---

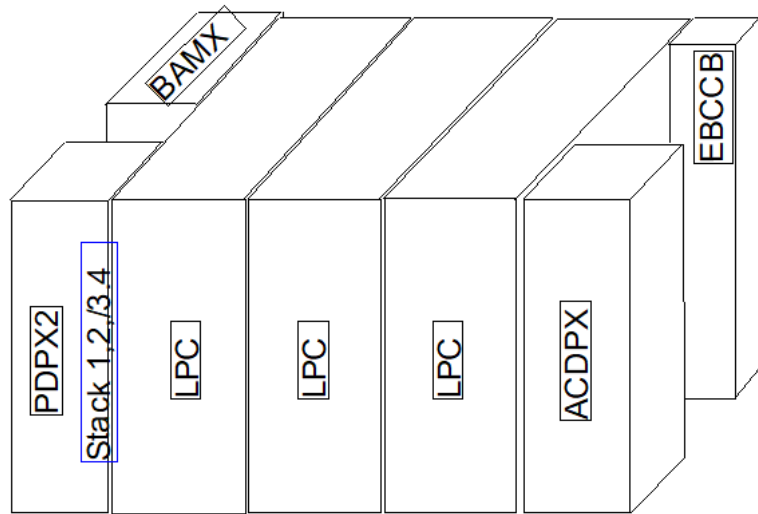


Figure 167: UACD for a redundant LTUW cabinet

### 7.18.1 UACD Equipment Part Numbers

Table 14 lists the equipment and corresponding part numbers of the UACD.

Table 11: UACD equipment part numbers for a redundant LTUW cabinet

Qty.	Name	Part number	Description
1	UACD (1)	S30805-G5405-X	Power supply and distribution cabinet for OpenScape 4500
1	ACDPX	S30050-K7028-X1	Power supply field
3	LPC, NG-Module	S30807-H6120-X1/X2	Component parts for main power supply modules with cable types
1	PDPX2	S30807-E6250-X	Terminal field
1	BAMX1	S30805-H5401-X11	Battery Manager 1, kit
	BAMX1	S30807-K6215-X1	Battery Manager 1
	BAEX	S30050-Q7048-X	Battery control and power failure management
1	EBCCB	S30807-K6710-X	Battery connection with safety cutout
1	UACD (2)	S30805-G5405-X	Power supply and distribution cabinet for OpenScape 4500
1	ACDPX	S30050-K7028-X1	Power supply field

## Connecting to the Mains and Power Supply

Qty.	Name	Part number	Description
3	LPC, NG-Module	S30807-H6120-X1/X2	Component parts for main power supply modules with cable types
1	PDPX2	S30807-E6250-X	Terminal field
1	BAMX2	S30805-H5401-X12	Battery Manager 2, kit
	BAMX2	S30807-K6215-X2	Battery Manager 2
1	EBCCB	S30807-K6710-X	Battery connection with safety cutout

### 7.18.2 UACD 1 Connections

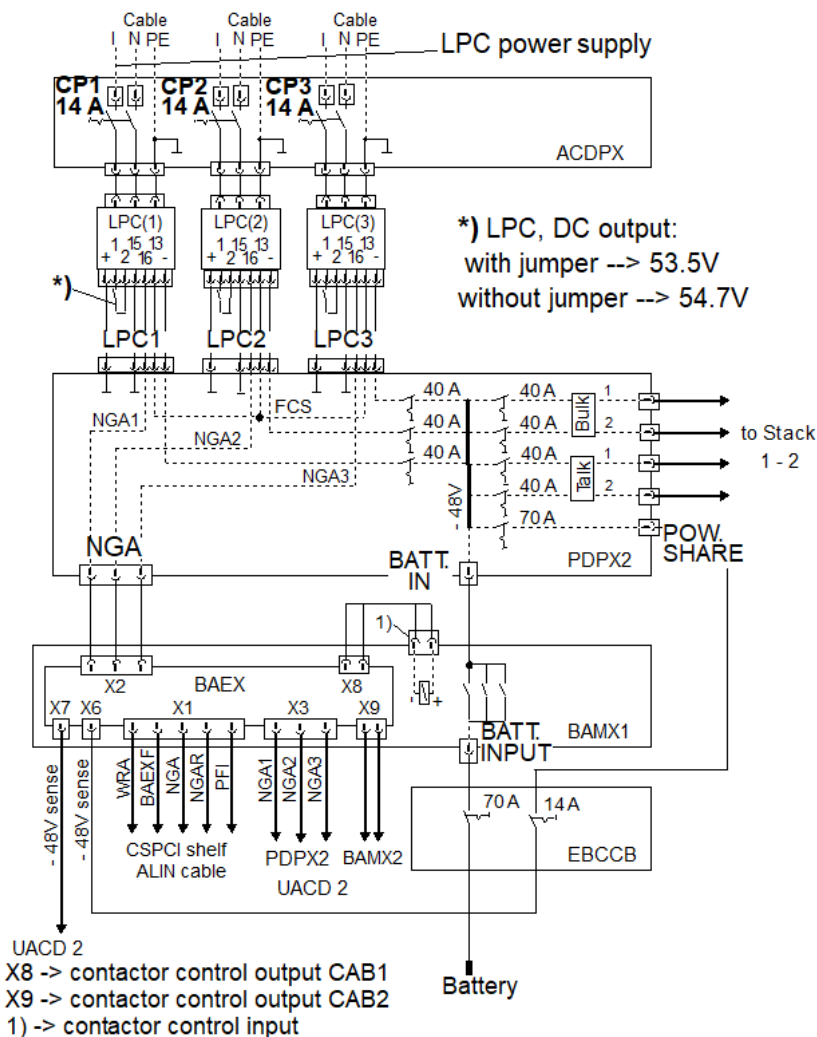


Figure 168: UACD 1 connections



## 7.19 Battery Manager Cabinet for L80XF Shelf

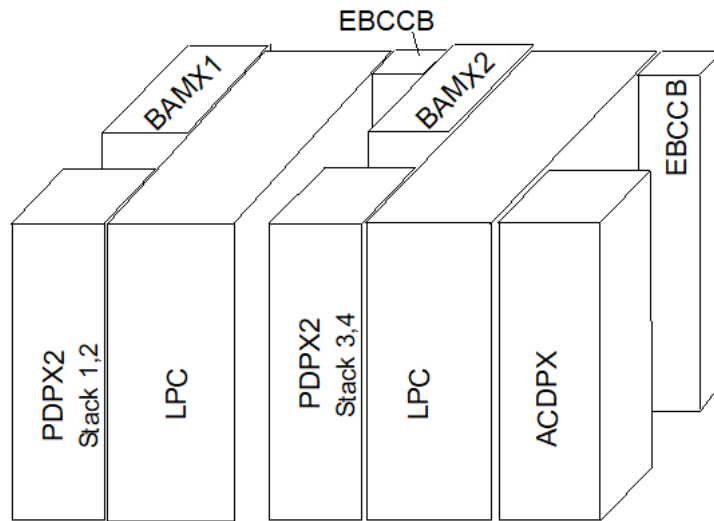


Figure 170: Battery Manager cabinet for L80XF shelf

### 7.19.1 Part Numbers for Battery Manager Cabinet

Table 15 lists the equipment and corresponding part numbers of the Battery Manager cabinet.

Table 12: Battery Manager cabinet equipment

Qty.	Name	Part number	Description
1	UACD	S30805-G5405-X	Power supply and distribution cabinet for H4000
1	ACDPX	S30050-K7028-X1	Power supply field
2	LPC, NG-Module	S30807-H6120-X1/ X2	Component parts for main power supply modules with cable types
1	PDPX2	S30807-E6250-X	DC terminal field
1	BAMX1	S30805-H5401-X11	Battery Manager 1, kit
	BAMX1	S30807-K6215-X1	Battery Manager 1
	BAEX	S30050-Q7048-X	Battery Control and Power Fail Management
1	EBCCB	S30807-K6710-X	Batt. conn. w. automatic circuit-breakers
1	PDPX2	S30805-H5401-X10	DC terminal field, kit
		S30807-E6250-X	DC terminal field

Qty.	Name	Part number	Description
1	BAMX2	S30805-H5401-X12	Battery Manager 2, kit
	BAMX2	S30807-K6215-X	Battery Manager 2
1	EBCCB	S30807-K6710-X	Batt. conn. w. automatic circuit-breakers
1	UACD	S30805-G5405-X	Power supply and distribution cabinet for H4000

### 7.19.2 Battery Manager, Connection Configurations

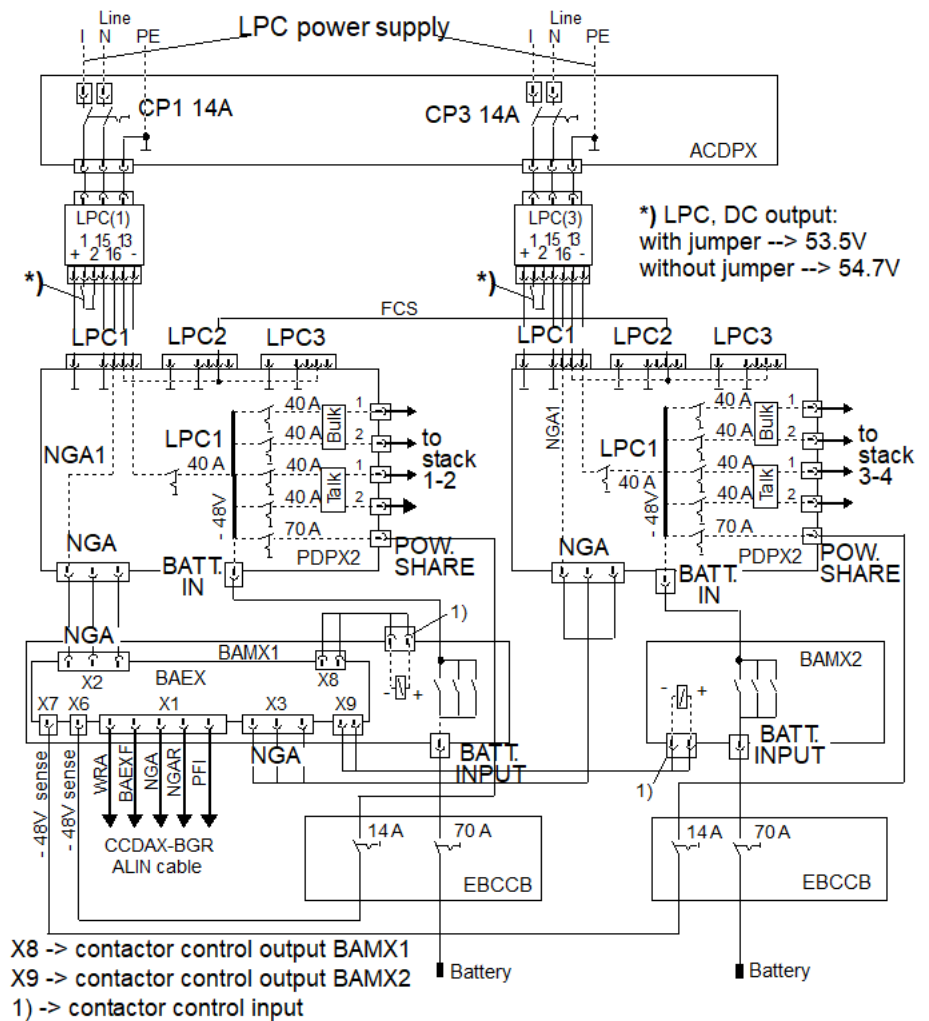
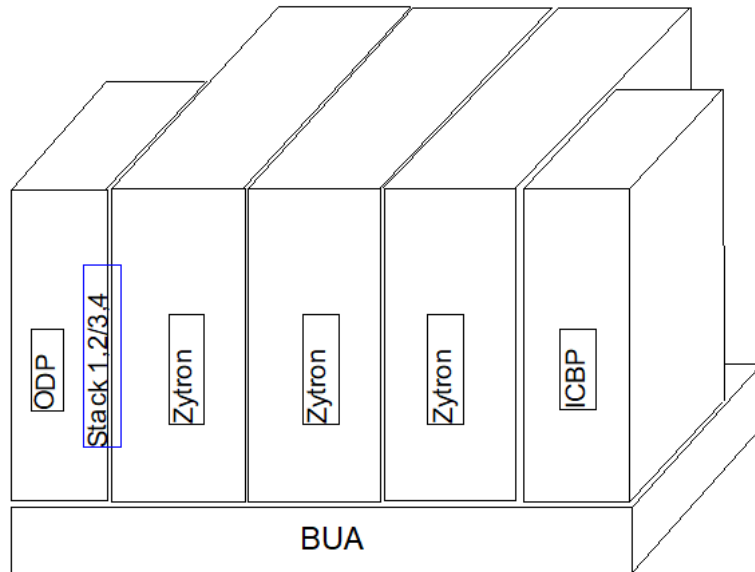


Figure 171: Battery Manager, connection configurations

**Connecting to the Mains and Power Supply**

UDCD (Zytron), North America Only

**7.20 UDCD (Zytron), North America Only**



**Figure 172: UDCD DC-to-DC power box (North America only)**

**7.20.1 UDCD Equipment Part Numbers, North America Only**

Table 16 lists the equipment and corresponding part numbers of the UDCD.

**Table 13: Equipment for UDCD DC-to-DC power box**

Qty.	Name	Part number	Description
1	BUA	S30805-G5409-X	Base Unit (Base unit assembly)
1	UDCD (1)	S30805-G5406-A	Unit DC Distribution
1	ICBP	S30807-E6588-X	Input circuit breaker panel
3	Zytron-Module	S30122-H5308-X	DC-to-DC converter
1	ODP	S30807-E6589-X	Output distribution panel
	DCPFX	S30807-Q6220-X	DC power fail card
1	UDCD (2)	S30805-G5406-X	Unit DC Distribution
1	ICBP	S30807-E6588-X	Input circuit breaker panel
3	Zytron-Module	S30122-H5308-X	DC-to-DC converter
1	ODP	S30807-E6589-X	
	DCPFX	S30807-Q6220-X	

## 7.20.2 Overview of UDCD stack 1 connections

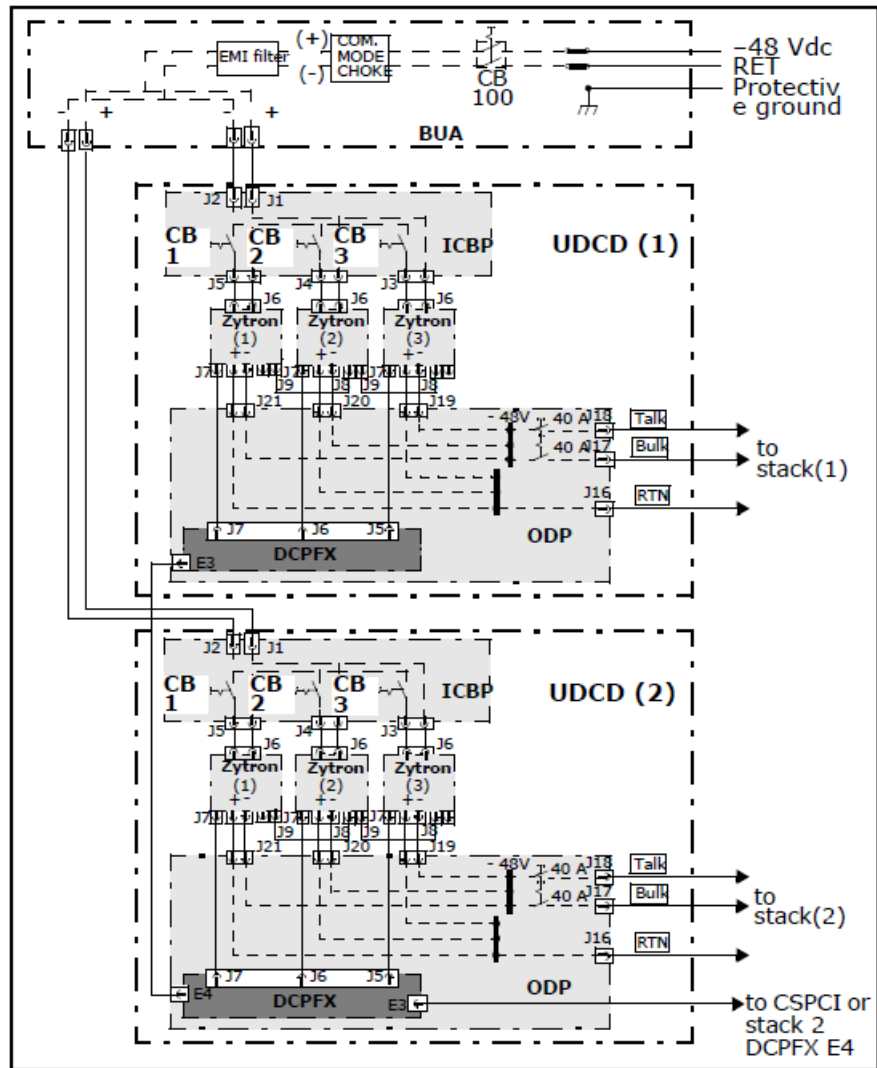


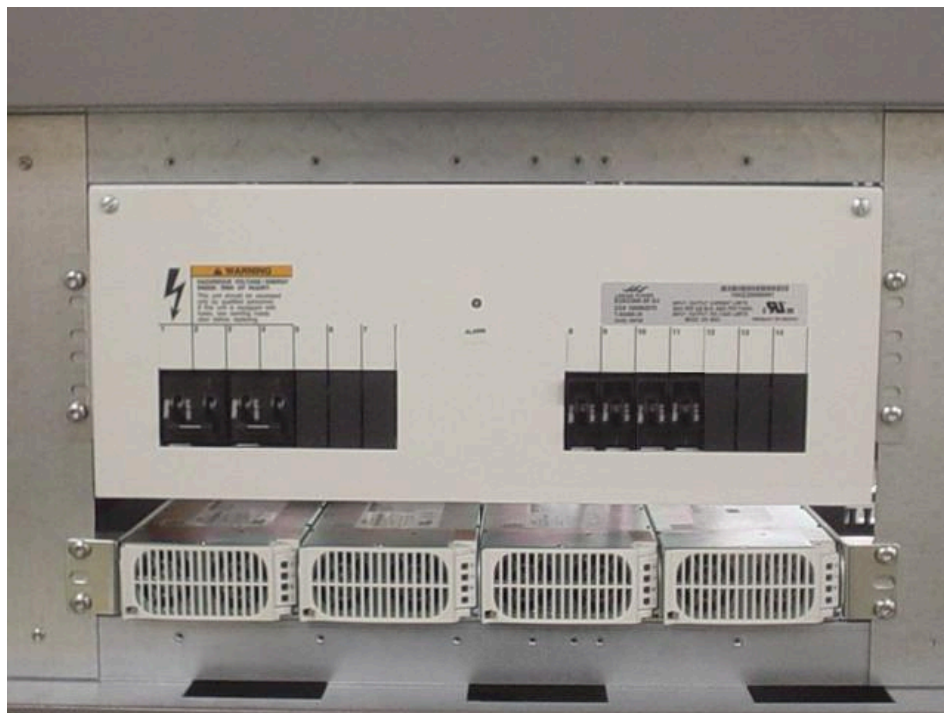
Figure 173: Overview of UDCD Stack 1 Connections

## 7.21 UDCD (Lineage Power)

The UDCD powerbox from Lineage Power will be used in the future as a replacement for the previous powerbox, which was fitted with Zytron power supplies.

**NOTICE:** The initial installation for the UDCD and their documentation will be covered by local company in US.

**Connecting to the Mains and Power Supply**  
 Connecting the Power Box to the System



**Figure 174: Lineage Powerbox (complete configuration)**

**7.22 Connecting the Power Box to the System**

To connect the power box to the system:

- 1) Attach the cable from connector X1 in the BAMX1 (BAEX) to the ALIN connector in the CSPCI box (stack 1).
- 2) From PDPX2 (1), stack 1/2, and PDPX2 (2), stack 3/4, connect one 48-V TALK and one 48-V BULK cable to the relevant 48-V connectors on the lower shelves at the back of each stack. [Table 17](#) and [Figure 85](#) show how to connect the bulk and talk cables from the BAMX to the OpenScape 4000 cabinets.

**Table 14: List of redundant -48-V connections between BAMX and a OpenScape 4000 cabinet**

Stack 1 (CABCCD)	Stack 2 (LTU..4)	Stack 3 (LTU..8)	Stack 4 (LTU..12)
TALK PDPX2 (1) to center -48-V connector	TALK NEW CAB PDPX2 (1) to center -48-V connector	TALK PDPX2 (2) to center -48-V connector	TALK NEW CAB PDPX2 (2) to center -48-V connector
BULK PDPX2 (1) to right -48-V connector	BULK NEW CAB PDPX2 (1) to right -48-V connector	BULK PDPX2 (2) to right -48-V connector	TALK NEW CAB PDPX2 (2) to right -48-V connector

Refer also to the [Section 7.23, "PSDXE Connection"](#) for additional information.

**Back**

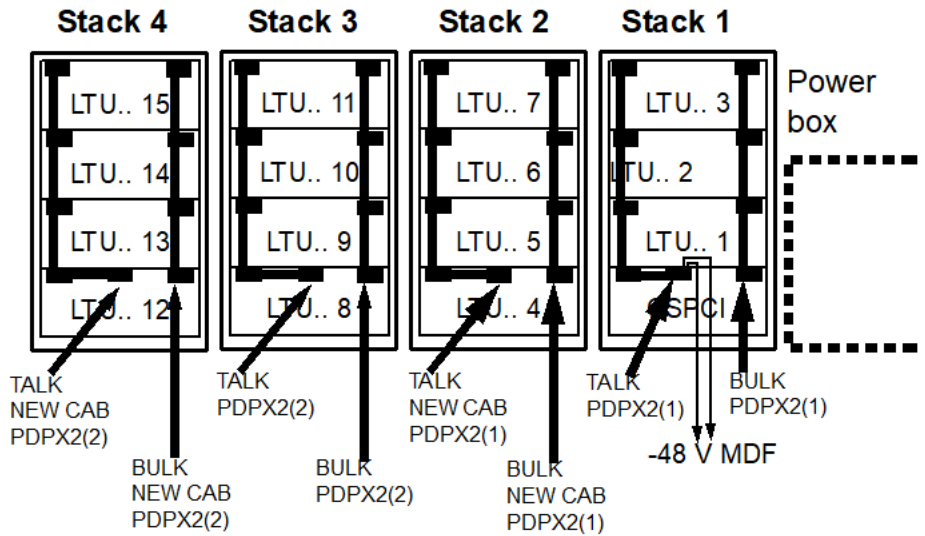


Figure 175: Redundant -48-V connections from PDPX2 to the shelves

**7.22.1 Connecting the MDF for a Redundant System, I.M.**

The power supply for the main distribution frame is branched from UACD 1 (48-V connector unit TALK PDPX2(1)) and connected to the main distribution frame by means of two 1.6-A fuses. (Refer to [Figure](#) ).

The 48 V connectors from the MDFs can be combined as required. Ensure that the number of MDFs connected at a fuse does not exceed the overall power requirement for each 1.6 A fuse.

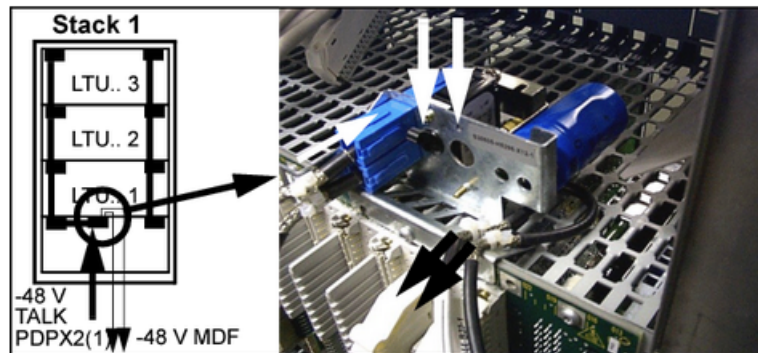


Figure 176: Redundant -48-V connection unit for MDF

The main distribution frame connection of 48 V is the same as that described in the [Section 7.13.2, "Connecting the MDF for a Non-redundant, System, I.M."](#).

**7.23 PSDXE Connection**

[Figure 87](#) shows the connectors in the PSDXE required for connecting the power supply and the battery manager to the system.

**Connecting to the Mains and Power Supply**  
Calculating the Battery Cabling, I.M.

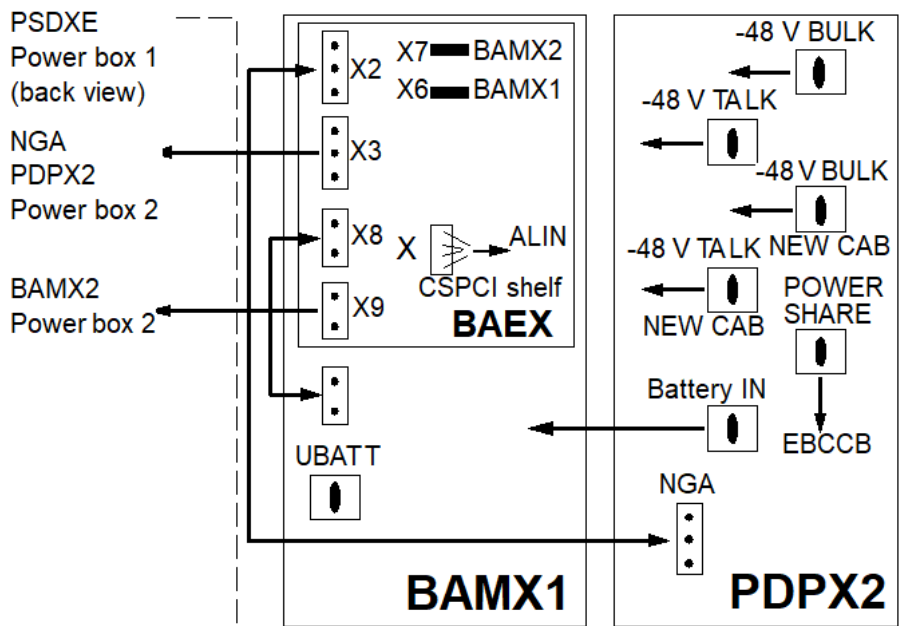


Figure 177: PSDXE connection

**7.24 Calculating the Battery Cabling, I.M.**

battery cable cross section	mm <sup>2</sup>							System power at	U <sub>v</sub>
	16 <sup>2</sup>	25 <sup>2</sup>	35 <sup>2</sup>	50 <sup>2</sup>	70 <sup>2</sup>	95 <sup>2</sup>	2x70 <sup>2</sup>		
Stack 1 PSU2	15	23	32	46	65	84	130	46 A	1.5 V
Stack 2 PSU3	10	15	22	31	43	56	86	69 A	
Stack 3 PSU4								23 A	
Stack 4 PSU5	15	23	32	46	65	84	130	46 A	
Stack 1 + Stack 2	10	15	22	31	43	56	86	69 A	
Stack 3 + Stack 4									

Figure 178: Battery cable cross-section

- Minimum system voltage 42.5 V at the BAEX module (in the BAMX1 in CABPSD)
- Permissible voltage drop (U<sub>v</sub>) on the battery cable, from the terminal to the battery, if the battery is to be discharged to 44V (1.83V/battery)
- The system current is based on the power supply units output as follows:
- – Maximum 2 UACDs with up to 6 power supply units (PSUs)
- – For every PSU -->continuous load 23 A
- – Maximum 23 A x n (PSU) (power supplies are in accordance to [Figure](#) )

**NOTICE:** If possible, the battery cable cross-section should not be less than 70 mm<sup>2</sup>, even in configurations with fewer than 6 PSUs. A cross-section of at least 70 mm<sup>2</sup> if the configuration is subsequently expanded to the maximum of 6 PSUs in order to ensure proofing against short-circuits. Expansions should always provide for a certain reserve, as otherwise, the battery cable must be

reinforced or replaced if the voltage drop (Uv) is exceeded at 1.5 V.

---

$\frac{2 \times \# \text{ (m)} \times * \text{ (qty)} \times 23 \text{ (A)}}{1.5 \text{ (Uv)} \times 58(\text{æ})} = \frac{?}{87} = \underline{\underline{?}} \text{ mm}^2 \text{ per +/- cable}$
<p>The formula must be supplemented with two values:</p> <p style="margin-left: 150px;">#) = Distance between system &amp; battery</p> <p style="margin-left: 150px;">*) = Required number of PSUs</p>

**Figure 179: Formula for calculating battery cable cross-section**

## 8 Internal Line Cables

This chapter provides instructions for installing internal cables on the OpenScope 4000 system.

### 8.1 Installing Signal Cables

Signal cables are referred to as LTU signal cables. Signal cables should already be connected when the system is shipped out of the factory. Should the cables become loose or removed during transit, install the signal cables on the OpenScope 4000 as follows:

---

**NOTICE:** To avoid a short-circuit, ensure that the power on the system is off before connecting and removing the LTU cables.

---

1) [Table 1](#) contains an overview of the signal cable connections between the LTUCA ports of the LTU/AP3700 expansion cabinets (see [Figure 1](#)) and the CSPCI backplane ports on the RTM board (see [Figure](#) ). The following default cable lengths are used depending on the installation variant:

- 2 m (in stack 1)
- 5 m (from stack 2-4)
- 5 m or 10 m (if the CSPCI frame is installed in the external 19" frame)

**Table 15: Signal cable connections to CSPCI/RTM**

System Type	From	To
Simplex	LTU.. 1 - LTU.. 15 (LTUCA board CCA)	CSPCI RTM(EBT 1/2)
Duplex	LTU.. 1 - LTU.. 15 (LTUCA board CCA)	CSPCI RTM (EBT 2/3)
	LTU.. 1 - LTU.. 15 (LTUCA board CCB)	CSPCI RTM(EBT 5/6)

The cables for trunk failure transfer, reference clock and alarm signaling are connected to the MCM board.

System Type	From	To
Simplex	LTU.. 1 - LTU.. 15 (LTUCA board CCA)	EcoServer RTMx
Duplex	LTU.. 1 - LTU.. 15 (LTUCA board CCA)	EcoServer RTMx

System Type	From	To
	LTU.. 1 - LTU.. 15 (LTUCA board CCB)	EcoServer RTMx

Signal cable connections to EcoServer/RTMx

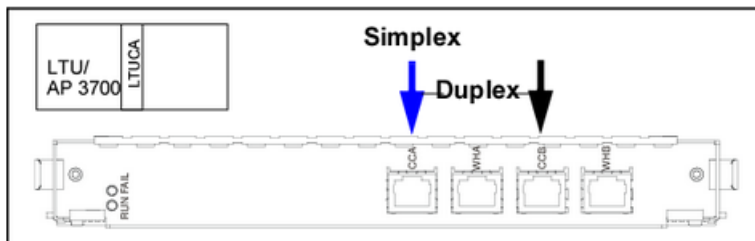


Figure 180: LTUCA board in the LTU/AP 3700 shelf (CCA/CCB)

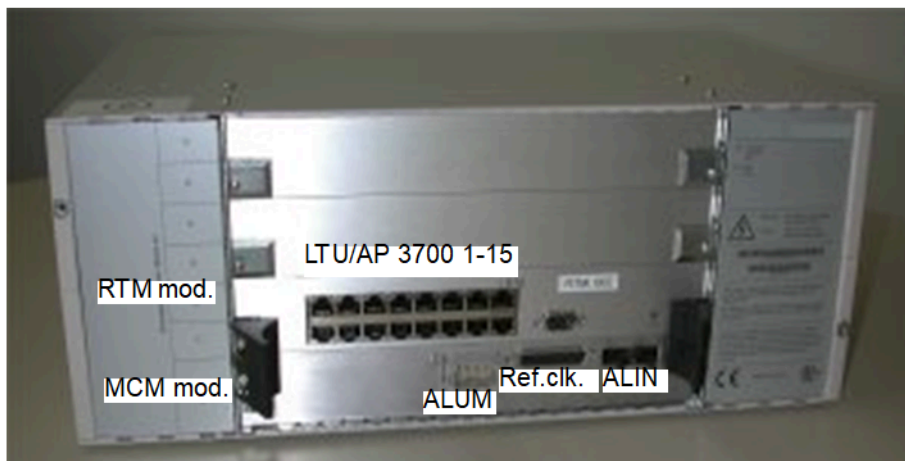
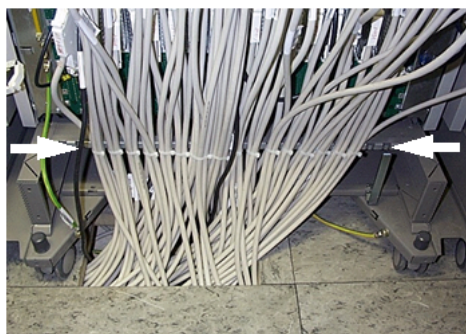


Figure 181: CSPCI backplane (RTM board), example simplex

- 2) All cables that lead to the main distribution frames (I.M.) must be attached to the relevant stack frames with cable fasteners (see [Figure](#) ).

































This figure shows the cable attachment points on the stack.

Figure 182: Attaching cables on the OpenScape 4000

### 8.1.1 Overview of EcoServer (RTMx) Connection to L80XF/LTUW/AP 3700 (LTUCA Board)

Table 16: Overview of EcoServer (RTMx) connection to L80XF/LTUW/AP 3700 (LTUCA board)

C39195- Z7211-A...	20	20	20	50	50	50	50	50	50	50	50	50	50	50	50
L80XF/ LTUW/ AP3700	1	2	3	4	5	6	7	8	9	10	11	12	13	14	15
Front LTUCA board	CCA	CCA	CCA	CCA	CCA	CCA	CCA	CCA	CCA	CCA	CCA	CCA	CCA	CCA	CCA
EcoServer 1															
Cab. connector	LTU1	LTU2	LTU3	LTU4	LTU5	LTU6	LTU7	LTU8	LTU9	LTU10	LTU11	LTU12	LTU13	LTU14	LTU15
1 x RTMx (mono) or 2 x RTMx, duplex	-----	-----	-----	-----	-----	-----	-----	-----	-----	-----	-----	-----	-----	-----	-----
Cab. connector	LTU1	LTU2	LTU3	LTU4	LTU5	LTU6	LTU7	LTU8	LTU9	LTU10	LTU11	LTU12	LTU13	LTU14	LTU15
EcoServer 2															
Front LTUCA board	CCB	CCB	CCB	CCB	CCB	CCB	CCB	CCB	CCB	CCB	CCB	CCB	CCB	CCB	CCB

C39195-Z7211-A...	20	20	20	50	50	50	50	50	50	50	50	50	50	50	50
L80XF/LTUW/AP3700	1	2	3	4	5	6	7	8	9	10	11	12	13	14	15



Figure 183: EcoServer backplane (RTMx)

### 8.1.2 Overview of CSPCI Peripheral Connections

Table 17: Overview of CSPCI peripheral connections

		Ext. I/F	Service PC	Maintenance	Host Slots	LTUCA/LTUCR Periph.	Maintenance	Ext. Clock Box	UA
		↑ Front	↑ Front	↑ Front	↑ Front	↑ Front	↑ Rear	↑ Rear	↑
CSPCI Board	SLOT>	1 / 2 / 5	----DSCXL2----			RTM		----MCM----	
KAST name		8 x LAN 8-8pos	1 x USB slave	1 x V.24 DSUB-9 VGA	2 x USB 2.0	15xLAN 1) 8-8pos	1 x V.24 DSUB-9 VGA	ref.clock 25-25pos	AL 10
C39195-Z7211-A..	7...120					20...100			
C39195-Z7702-A20			20						
S30267-Z355-A..							25		
C39195-Z7615/7602-A..				30/100					
Standard commercial USB cable					X				

## Internal Line Cables

C39195-Z7612-A..3)

C39195-Z7613-A..

C39195-Z7614-A..4)

External cable

X

S30122-X8011-X10

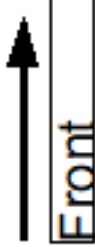
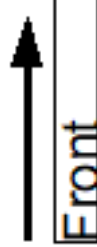
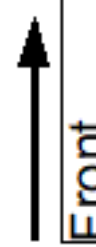
25

1) 15 LAN cable for LTU1...LTU15 (AP3700 --> 1 ... 15), see also label on RTM panel (cable lengths: 2m, 5m, 10m)

## 8.1.3 Overview of EcoServer Periphery Connections

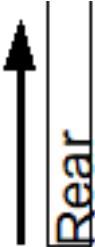
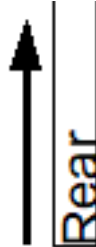
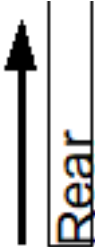
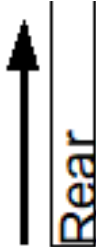
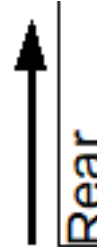
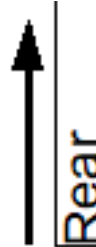
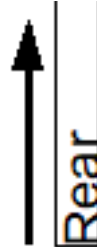
### 8.1.3.1 Front

Table 18: Overview of EcoServer periphery connections

	Service	Maintenance	Display Port
			
EcoServer			
KASt name	1 x USB slave	4 x USB USB 2-5	HDMI
C39195-Z7702-A20	20		
Standard commercial USB cable		X	
C39195-Z7617-A1			20

### 8.1.3.2 Back

**Table 19: Overview of EcoServer periphery connections**

	for RTMx duplex config.	LTUCA/LTUCR Periph.	External clock box	UACD Box	MDF IM / US	Main board ext. I/F	Remote I/F
							
EcoServer	-----RTMx-----						
KAST name	Cross-connect	15 x LAN 1) 8-8pos	Ref.clock SUB-D 25	ALIN SUB-D 9	ALUM SUB-D 15	8 x LAN 8-8pos.	1 x LAN 1-Gbit
	SCSI2 50-50pos.		25-25pos.		-open	1-Gbit	
C39195-Z7211-A..		20...100				7...120	
C39195-Z7612-A..					100... 950 (IM)		
C39195-Z7613-A...					Patch panel (IM) 50 / 150		
C39195-Z7614-A..					100/ 150 (US)		
External cable			X				
C39195-Z7409-A1	130mm						
S30122-X8011-X12				50			
C39195-Z7702-A20							20

1) 15 LAN cable for LTU1...LTU15 (AP3700 --> 1 ... 15), see also label on EcoServer rear side (15 x Lan, cable lengths: 2m, 5m, 10m).

## 8.1.4 Replacing Cross-Connect Cables



---

**CAUTION:** The cross-connect cable must not be unplugged or plugged into the active server when the system is online, unless the server is in standalone mode.

---

To avoid malfunctions when inserting the cross-connect cable, connect the cable depending on the application in the sequence described below:

### 8.1.4.1 Application 1: A server in the duplex system is defective:

- 1) Switch off the defective server using the Power button.
- 2) Remove the power cable.
- 3) Remove the cross-connect cable on the defective server only (do not remove the cross-connect cable from the active server as this would trigger a restart of the active server).
- 4) Replace the EcoServer.
- 5) Connect the cross-connect cable, which is still plugged into the active server, to the second EcoServer.
- 6) Connect the power cable to the second EcoServer and switch on the power supply.

### 8.1.4.2 Application 2: Replacing the cross-connect cable / operation without cross-connect cable:

- 1) First remove the cross-connect cable from the standby server.
- 2) Switch the active server to standalone mode (see "Separated Duplex": standalone\_operation enable).
- 3) You can now also remove the cross-connect cable from the standalone server.
- 4) Now connect the new cross-connect cable to the two EcoServers, starting with the active server.
- 5) Standalone mode is disabled automatically when the cross-connect cable is connected.

### 8.1.4.3 Application 3: Switching from standalone to duplex:

#### Starting situations

- 1) Operation of the first system with connected cross-connect cable.
  - a) Connect the cross-connect cable to the second EcoServer.
  - b) Connect the power cable to the second EcoServer and switch on this server.

- 2) Operation of the first system in standalone mode.
  - a) Connect the cross-connect cable supplied to the EcoServer that is running in standalone mode.
  - b) Now connect the cross-connect cable to the second EcoServer (standby).
  - c) Connect the power cable to the second EcoServer.
  - d) Switch on the power supply for the second EcoServer.

The active server in standalone mode detects the second EcoServer by means of the cross-connect cable and automatically switches from standalone mode to duplex mode.

## 8.2 Installing the Service Alarm Cable and Trunk Bypass

To install the service alarm cable and trunk bypass on the OpenScape 4000:

The connectors for the alarm interface and trunk failure transfer are located on the rear of the EcoServer.

- 1) Insert the cable for the trunk bypass (S30267-Z7612-A\*), (S30267-Z7613-A\*), (S30267-Z7614-A\*) in the DSUB jack (ALUM jack).
- 2) Connect the open end cable to the MDF (or the cable (S30267-Z7613-A\*) to the patch panel).
- 3) Connect the cable (S30122-X8011-X10) for the alarm interface to the ALIN connector on the EcoServer and connect the other end of the cable to the ALIN connector on the UACD box.

## 9 External Cabling Assemblies

This chapter provides installation and cabling diagrams for the OpenScope 4000 system. Diagrams for the IPDA are located in the associated chapter. Unless otherwise noted, all diagrams apply to both U.S. and I.M. installations.

This section describes the assembly of the main distribution frames and the cables that must be connected from the MDF splitting strips to the corresponding LTU/AP 3700 slots in the OpenScope 4000 (also refer to the cable plugging list that accompanies the relevant system). Two different MDFs can be used (MDFHX6) depending on the system configuration.

---

**NOTICE:** In new installations, always connect shielding wires. Do not modify existing shielding wires if a main distribution frame is already being used. Do not use shielding wires for ground distribution. Use the YV 2x0.5/0.9 jumper wires for jumpering.

---

### 9.1 MDFHX6 Assembly, I.M.

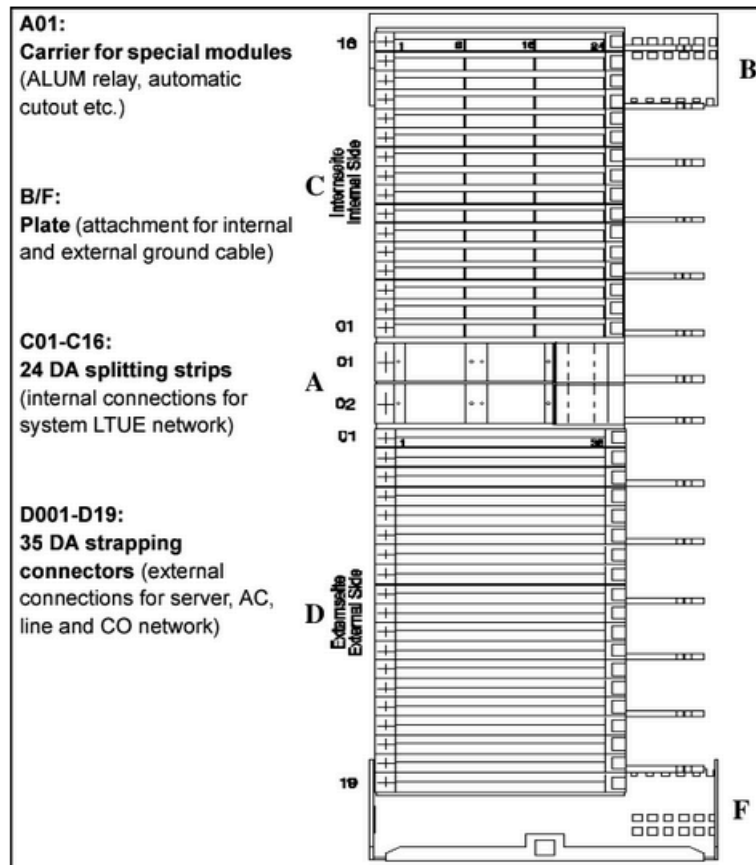


Figure 184: MDFHX6 assembly

### 9.1.1 Cabling from the LTU to the MDF, I.M.

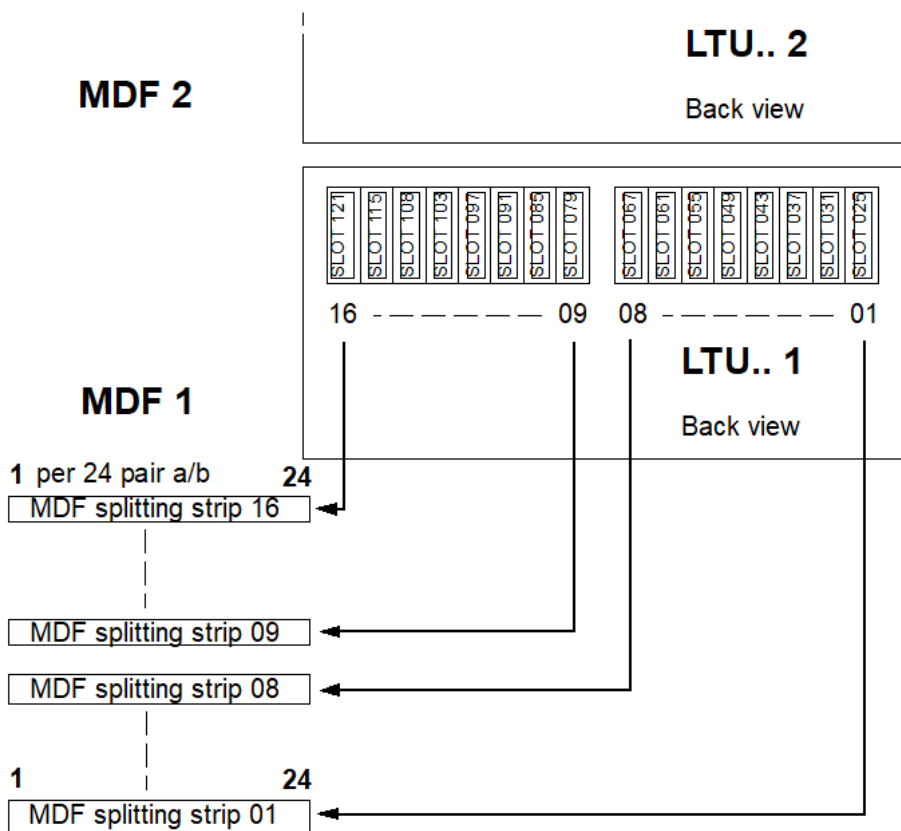


Figure 185: LTU to MDF cabling

### 9.1.2 Cable Routing from AP 3700-13 Cabinet to the MDF, I.M.

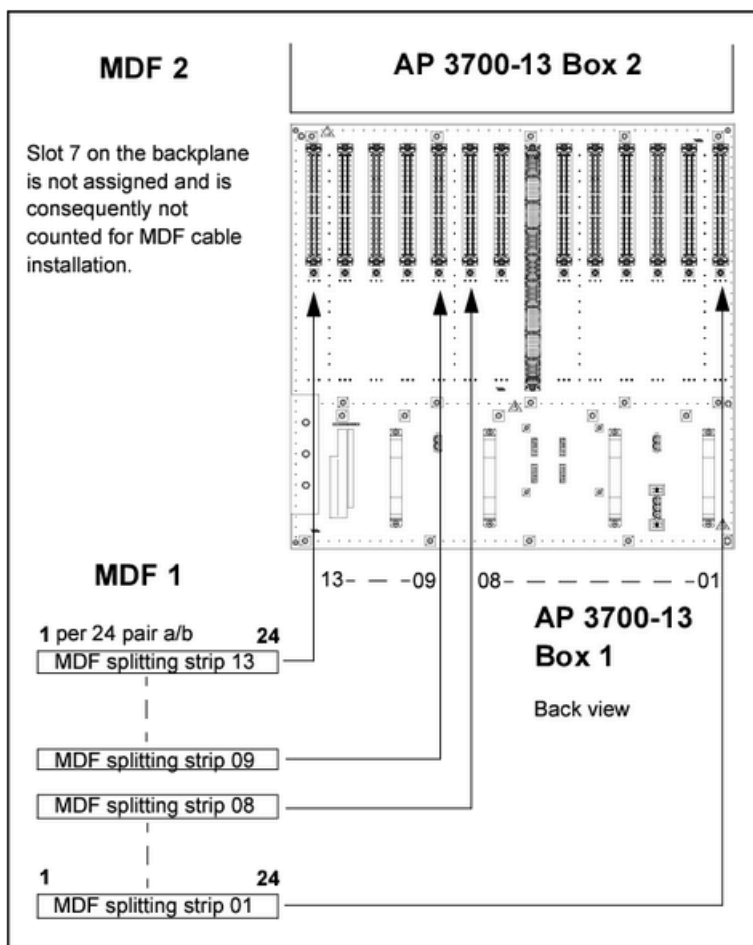


Figure 186: Cable routing from AP 3700-13 cabinet to MDFHX6

### 9.2 Overvoltage Protection of the Modules, I.M.

---

**NOTICE:** Lightning protection on the boards: Analog and digital subscriber lines are protected on the boards using protection up to 2KV longitudinal voltage and 1KV transverse voltage against high-energy overvoltage in pulses from 10/700us and 1.2/50us, which can be induced by a lightning strike. This protection is only effective, however, if the system is grounded correctly in accordance with the assembly guidelines. Grounding: Once OpenScope 4000 has been grounded, check the low-impedance grounding of the system via the ground connector of the power supply circuit as well as the low-impedance connection of the additional permanently connected protective grounding conductor to the building's equipotential busbars.

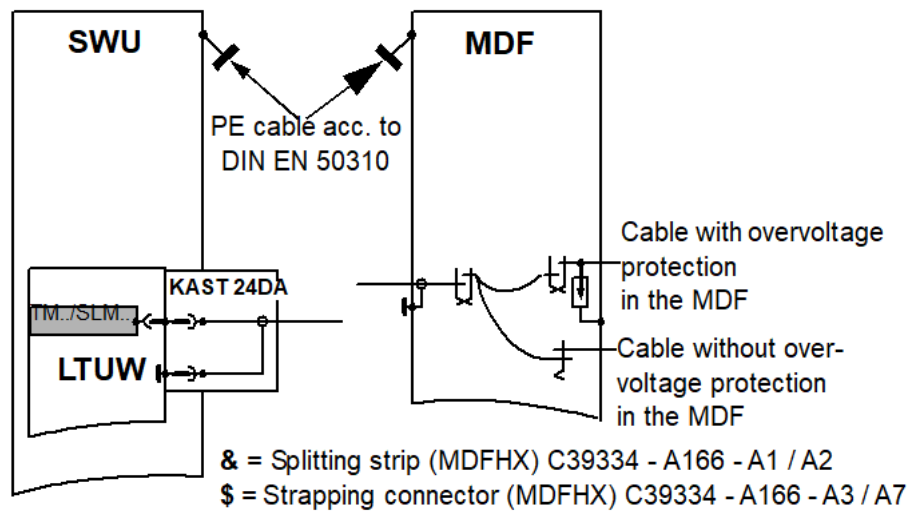
---

**NOTICE:** External lightning protection: With line lengths of over 500m and if the lines leave the building, analog and digital subscriber boards must be protected by external lightning

protection. This type of lightning protection is referred to as "additional primary protection". This is either installed on the main distribution frame (MDF) or at the entry point of the line into the building. A surge arrester (ÄsAG) with a rated voltage of 230V is switched to ground by every lead that is to be protected. Without this additional primary protection, lightning which exceeds the voltage values described above can lead to the destruction of the boards. This can result in failure of the overall system or to overheating (risk of fire) of components.

Overvoltage protection is integrated in the module for 24DA cables. The cable connectors do not contain any other overvoltage protection devices.

Where necessary, you can use overvoltage protectors to protect external cables to the main distribution frame against atmospheric pressure.



**Figure 187: Installing additional primary protection**

### 9.3 MDF Cable Connections, I.M.

**IMPORTANT:** PIN assignment is different on the LTUW backplane and the cable connectors!

**Table 20: MDF 16DA/24DA cabling**

Connect. Cable Pin		Connect. Cable Pin		Connect. Cable Pin	
ModCab Pin	Wire Cable Color Wire Ring	ModCab Pin	Wire Cable Color Wire Ring	ModCab Pin	Wire Cable Color Wire Ring
1 20	1a White-- Blue	17 4	9a Red-- Brown	43 58	17a Yellow-- Orange

## External Cabling Assemblies

Connecting the Signal or Alarm Cables to the MDF, I.M.

Connect. Cable				Connect. Cable				Connect. Cable			
Pin				Pin				Pin			
23	38	1b	Blue-- White	18	3	9b	Brown-- Red	44	57	17b	Orange-- Yellow
3	18	2a	White-- Orange	19	2	10a	Red-- Gray	45	56	18a	Yellow-- Green
4	17	2b	Orange-- White	20	1	10b	Gray-- Red	46	55	18b	Green-- Yellow
5	16	3a	White-- Green	24	37	11a	Black-- Blue	47	54	19a	Yellow-- Brown
6	15	3b	Green-- White	25	36	11b	Blue-- Black	48	53	19b	Brown-- Yellow
7	14	4a	White-- Brown	26	35	12a	Black-- Orange	49	52	20a	Yellow-- Gray
8	13	4b	Brown-- White	27	34	12b	Orange-- Black	50	51	20b	Gray-- Yellow
9	12	5a	White-- Gray	29	32	13a	Black-- Green	51	50	21a	Violet-- Blue
10	11	5b	Gray-- White	30	31	13b	Green-- Black	52	49	21b	Blue-- Violet
11	10	6a	Red-- Blue	31	30	14a	Black-- Brown	53	48	22a	Violet-- Orange
12	9	6b	Blue-- Red	32	29	14b	Brown-- Black	54	47	22b	Orange-- Violet
13	8	7a	Red-- Orange	34	27	15a	Black-- Gray	55	46	23a	Violet-- Green
14	7	7b	Orange-- Red	35	26	15b	Gray-- Black	56	45	23b	Green-- Violet
15	6	8a	Red-- Green	37	24	16a	Yellow-- Blue	57	44	24a	Violet-- Brown
16	5	8b	Green-- Red	38	23	16b	Blue-- Yellow	58	43	24b	Brown-- Violet

### 9.4 Connecting the Signal or Alarm Cables to the MDF, I.M.

Connect the signal or alarm cable to the MCM board (ALUM connector) and to the main distribution frame on splitting strip D1 (only on MDF1). For D1 splitting strip, see [Figure 1](#)).

#### ALUM (trunk failure transfer)

The following three signals from the EcoServer hardware are routed via this interface:

- ALUM (trunk failure transfer), max. 1A/30W
- – ALUM off: System is ok (ALUM contact is closed)
  - ALUM on: System had a problem, e.g. reload (ALUM contact is open)
- NAL (Not urgent Alarm)
- UAL (Urgent Alarm)

These signals are transmitted via relays to the front connector (15-pin), which is connected in turn to the main distribution frame via the cable C39195-Z7612-A\* (DSub connector, open end).

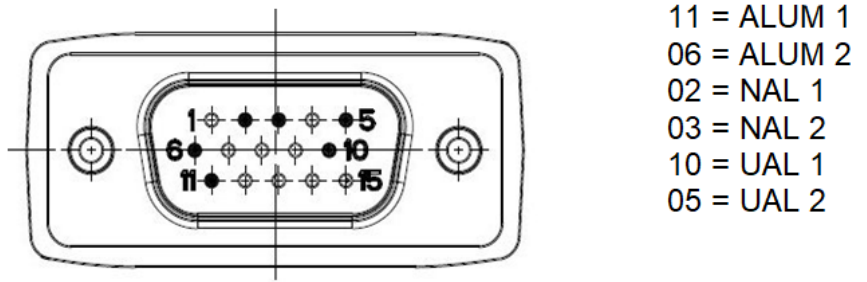


Figure 188: ALUM pin assignment

ALUM cable types

Table 21: ALUM cable types

Sachnummer /	Type	Cable length
C39195-Z7612-A100	ASW cable to MDF (release for IM)	10m
C39195-Z7612-A200	ASW cable to MDF (release for IM)	20m
C39195-Z7612-A550	ASW cable to MDF (release for IM)	55m
C39195-Z7612-A950	ASW cable to MDF (release for IM)	90m
C39195-Z7613-A50	ASW cable to patch panel (release for IM)	5m
C39195-Z7614-A100	ASW cable to MDF (release for US)	10m
C39195-Z7614-A150	ASW cable to MDF (release for US)	15m

### 9.5 Connecting Subscriber Line Modules/Trunk Boards

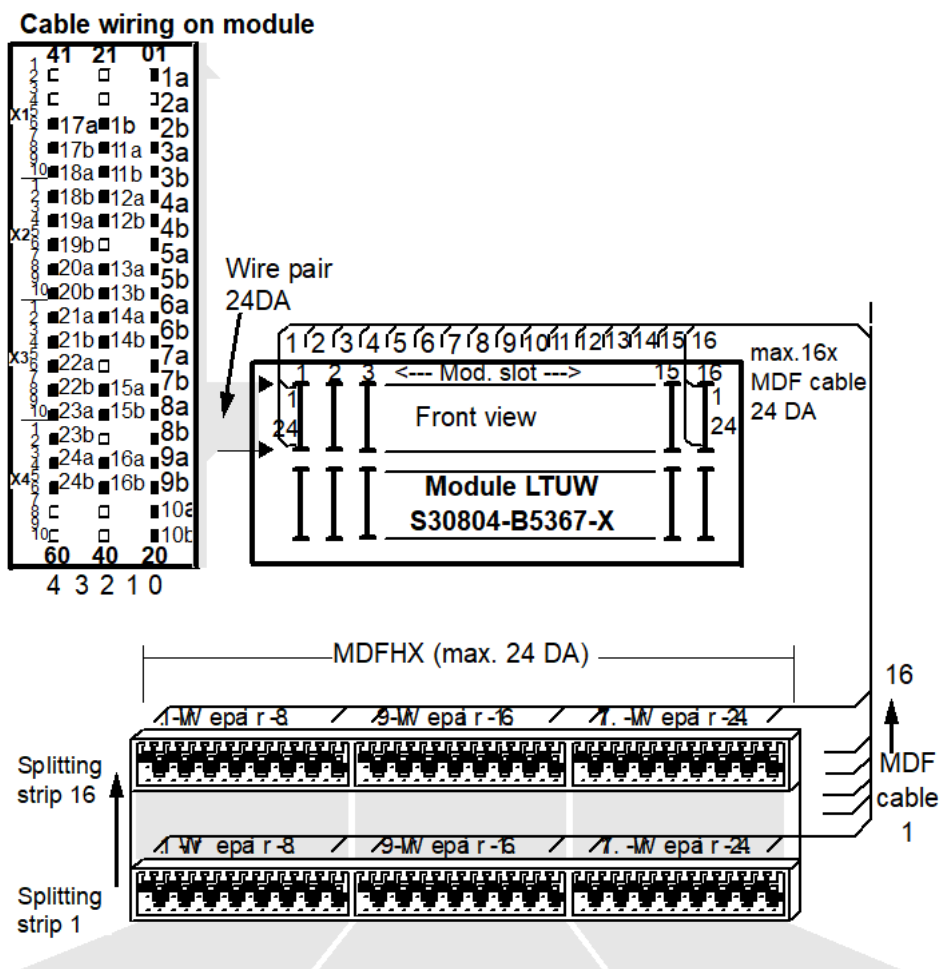


Figure 189: Connecting subscriber line modules/trunk boards

#### 9.5.1 Subscriber-Line Module Boards

Table 22: Subscriber line modules and part numbers

Part No. S30810-	Board Abbreviation	Remarks
-Q6194 -X	SLCSM	
-Q2153 -X	SLMQ	
-Q2153 -X100	SLMQ	
-Q2141 -X	SLMA	
-Q2191 -X	SLMA3	
-Q2246 -X	SLMA	

Part No. S30810-	Board Abbreviation	Remarks
Q2191-C	SLMAC	
Q2225-X	SLMAE	
Q2227-X	SLMAV	Replaces SLMAC and SLMAE
-Q2193-X100	SLC24	Symmetrical signaling lines
-Q2193-X200	SLC24	Asymmetrical signaling lines
-Q2479 -X	SLMQ3	
-Q2160 -X	STMA	OWG-multimode
-Q2160 -X100	STMA	OWG-singlemode
-Q2163-X	STMD2	
-Q2163-X100	STMD2	
-Q2168-X	SLMO2	
-Q2174 -X	STMD	
-Q2177 -X	STHC	
-Q2184 -X	SLMAB	
-Q2169 -X100	SLMOP	
-Q2480 -X	SLMAR	
-Q2809 -X100	SLMT	Project-specific
-Q2816 -X	SLMY	
-Q2324-500X	STMI4	
-Q2324-510X	STMI4	
-Q2815-X	STMVI	

### 9.5.1.1 Connecting the Subscriber Line Modules

Table 4 lists the line connections for the subscriber line modules.

External Cabling Assemblies

Table 23: Subscriber line module connections

..... Subscriber Circuits .....																									
ID/ Part No.	HW ID	Dial Mode			Range			Type of Operation												per a/b					
		DTI	DP	Pro	ISD	Damping			Remarks												Mo	PE			
S30810-		Dig															Circuit								
MDF cable a/b no., circuit no. per module, wire identification per circuit																									
1	2	3	4	5	6	7	8	9	10	11	12	13	14	15	16	17	18	19	20	21	22	23	24		
SLC24								X	1 km			LT - digital UP0/E												24	1
-Q2193 -X								X	For local feed; dependent on cable type			4 x B (48 Kbps) + D (24 Kbps)													
1	2	3	4	5	6	7	8	9	10	11	12	13	14	15	16	17	18	19	20	21	22	23	24		
---	---	---	---	---	---	---	---	---	---	---	---	---	---	---	---	---	---	---	---	---	---	---	---		
a	a	a	a	a	a	a	a	a	a	a	a	a	a	a	a	a	a	a	a	a	a	a	a		
b	b	b	b	b	b	b	b	b	b	b	b	b	b	b	b	b	b	b	b	b	b	b	b		
SLMA		001XH		X	X				2 x 750 Ohm			TS - analog Dual SICOFI												16	1
-Q2141 -X								0 dB Â± 0.3 dB			for DP and DTMF terminals														
						7 dB Â± 0.3 dB																			
1	2	3	4	5	6	7	8	9	10	11	12	13	14	15	16										
---	---	---	---	---	---	---	---	---	---	---	---	---	---	---	---										
a	a	a	a	a	a	a	a	a	a	a	a	a	a	a	a										
b	b	b	b	b	b	b	b	b	b	b	b	b	b	b	b										
SLMAR		EBOXH		X	X				2 x 600 Ohm			TS - analog Quad- SICOFI												8	1
-Q2480 -X								3 dB Â± 0.3 dB (FRG) -10 dB Â± 0.3 dB (FRG)			for DP and DTMF terminals														
1	2	3	4	5	6	7	8																		
---	---	---	---	---	---	---	---																		
a	a	a	a	a	a	a	a																		
b	b	b	b	b	b	b	b																		
SLMA2		EC0XH		X	X				2 x 600 Ohm			TS - analog Quad- SICOFI												24	1
-Q2246 -X								3 dB Â± 0.3 dB (FRG) -10 dB Â± 0.3 dB (FRG)			for DP and DTMF terminals														

..... Subscriber Circuits .....																							
ID/ Part No.	HW ID				Dial Mode DTI DP Pro ISD				Range Damping				Type of Operation Remarks				per a/b Mo PE Circuit						
S30810-					Dig																		
MDF cable a/b no., circuit no. per module, wire identification per circuit																							
1	2	3	4	5	6	7	8	9	10	11	12	13	14	15	16	17	18	19	20	21	22	23	24
1	2	3	4	5	6	7	8	9	10	11	12	13	14	15	16	17	18	19	20	21	22	23	24
---	---	---	---	---	---	---	---	---	---	---	---	---	---	---	---	---	---	---	---	---	---	---	---
a	a	a	a	a	a	a	a	a	a	a	a	a	a	a	a	a	a	a	a	a	a	a	a
b	b	b	b	b	b	b	b	b	b	b	b	b	b	b	b	b	b	b	b	b	b	b	b
SLMOP	009XH								X	X	1 km				TS - digital UP0/E				24	1			
-Q2180	-X								For local feed;				2 x B (64 Kbps)										
									dependent on cable				+ D (16 Kbps)										
									resistance														
1	2	3	4	5	6	7	8	9	10	11	12	13	14	15	16	17	18	19	20	21	22	23	24
---	---	---	---	---	---	---	---	---	---	---	---	---	---	---	---	---	---	---	---	---	---	---	---
a	a	a	a	a	a	a	a	a	a	a	a	a	a	a	a	a	a	a	a	a	a	a	a
b	b	b	b	b	b	b	b	b	b	b	b	b	b	b	b	b	b	b	b	b	b	b	b
SLMO2	80FXH								X	X	1 km				TS - digital UP0/E				24	1			
-Q2168	-X								For local feed;				2 x B (64 Kbps)										
									dependent on cable				+ D (16 Kbps)										
									resistance														
1	2	3	4	5	6	7	8	9	10	11	12	13	14	15	16	17	18	19	20	21	22	23	24
---	---	---	---	---	---	---	---	---	---	---	---	---	---	---	---	---	---	---	---	---	---	---	---
a	a	a	a	a	a	a	a	a	a	a	a	a	a	a	a	a	a	a	a	a	a	a	a
b	b	b	b	b	b	b	b	b	b	b	b	b	b	b	b	b	b	b	b	b	b	b	b
SLMQ	078XH								X	5.5 ... 9 km				TS - digital or 2B1Q-Uk0 NT				16	1				
-Q2133	-X								For local feed;				PABX or 2 x B (64 Kbps)										
									dependent on cable				LT-+NT operation + D (16 Kbps)										
									resistance														
1	2	3	4	5	6	7	8	9	10	11	12	13	14	15	16								
---	---	---	---	---	---	---	---	---	---	---	---	---	---	---	---								
a	a	a	a	a	a	a	a	a	a	a	a	a	a	a	a								
b	b	b	b	b	b	b	b	b	b	b	b	b	b	b	b								

**External Cabling Assemblies**

..... Subscriber Circuits .....																							
ID/ Part No.	HW ID	Dial Mode			Range			Type of Operation			per a/b												
		DTI	DP	Pro	ISD	Damping			Remarks			Moc PE											
S30810-		Dig									Circuit												
MDF cable a/b no., circuit no. per module, wire identification per circuit																							
1	2	3	4	5	6	7	8	9	10	11	12	13	14	15	16	17	18	19	20	21	22	23	24
SLMQ	07AXH						X	X	5.5 ... 9 km			LT - digital or 2B1Q-Uk0 LT-+NT			16	1							
-Q2153	-X	07CXH					X	X	For local feed;			2 x B (64 Kbps) + D (64 Kbps)											
-X100									dependent on cable resistance														
1	2	3	4	5	6	7	8	9	10	11	12	13	14	15	16								
---	---	---	---	---	---	---	---	---	---	---	---	---	---	---	---								
a	a	a	a	a	a	a	a	a	a	a	a	a	a	a	a								
b	b	b	b	b	b	b	b	b	b	b	b	b	b	b	b								
STMD	077XH							X	1000 m			TS/AS - digital ISDN, S0 2 x B			8	2							
-Q2174	-X								(to NT)			(64 Kbps)											
												+ D (16 Kbps)											
												R=receive, T=transmit											
1	1	2	2	3	3	4	4	5	5	6	6	7	7	8	8								
---	---	---	---	---	---	---	---	---	---	---	---	---	---	---	---								
a0	a1	a2	a3	a4	a5	a6	a7	a8	a9	a10	a11	a12	a13	a14	a15								
b0	b1	b2	b3	b4	b5	b6	b7	b8	b9	b10	b11	b12	b13	b14	b15								
S0	S0	S0	S0	S0	S0	S0	S0	S0	S0	S0	S0	S0	S0	S0	S0								
R	T	R	T	R	T	R	T	R	T	R	T	R	T	R	T								
STHC	375XH							X	1000 m			TS/AS - digital UP0/E 2 x B (64			16	1							
-Q2177	-X								(extended bus 500			Kbps) S0											
									m			+ D (16 Kbps)											
									short bus 150 m			R=receive, T=transmit											
									in subscriber mode)														
1	2	3	4	5	6	7	8	9	10	11	12	13	14	15	16	17	17	18	18	19	19	20	20
---	---	---	---	---	---	---	---	---	---	---	---	---	---	---	---	---	---	---	---	---	---	---	---
a0	a1	a2	a3	a4	a5	a6	a7	a8	a9	a10	a11	a12	a13	a14	a15	a16	a17	a18	a19	a20	a21	a22	a23
b0	b1	b2	b3	b4	b5	b6	b7	b8	b9	b10	b11	b12	b13	b14	b15	b16	b17	b18	b19	b20	b21	b22	b23
																S0	S0	S0	S0	S0	S0	S0	S0
																R	T	R	T	R	T	R	T

..... Subscriber Circuits .....																							
ID/ Part No.	HW ID	Dial Mode			Range			Type of Operation			per a/b			Mo PE			Circuit						
S30810-		DTI	DP	Pro	ISD	Damping			Remarks														
		Dig.																					
MDF cable a/b no., circuit no. per module, wire identification per circuit																							
1	2	3	4	5	6	7	8	9	10	11	12	13	14	15	16	17	18	19	20	21	22	23	24
STMD2	075XH							X	1000 m						TS/AS - digital ISDN, S0 2 x B	8	2						
-Q2163 -X	074XH								(to NT)						(64 Kbps)								
-X100															+ D (16 Kbps)								
															R=receive, T=transmit								
1	1	2	2	3	3	4	4	5	5	6	6	7	7	8	8								
---	---	---	---	---	---	---	---	---	---	---	---	---	---	---	---								
a0	a1	a2	a3	a4	a5	a6	a7	a8	a9	a10	a11	a12	a13	a14	a15								
b0	b1	b2	b3	b4	b5	b6	b7	b8	b9	b10	b11	b12	b13	b14	b15								
S0	S0	S0	S0	S0	S0	S0	S0	S0	S0	S0	S0	S0	S0	S0	S0								
R	T	R	T	R	T	R	T	R	T	R	T	R	T	R	T								

### 9.5.2 Trunk Module Part Numbers

Table 24: Subscriber line modules and part numbers

Part No. S30810-	Board Abbreviation	Remarks
Q2226-X200	DIUT2	
Q2327-X100	TMANI	
Q2197-T	TMDID	
-Q2012 -X100	TMEM	
-Q2064 -X100	TMLR	
-Q2123 -X	TMLBL	
-Q2123 -X100	TMLBL	
-Q2147 -X	TMSFP	
-Q2147 -X300	TMSFP	
-Q2147 -X400	TMSFP	
-Q2159 -X100	TM2LP	

**External Cabling Assemblies**

Part No. S30810-	Board Abbreviation	Remarks
-Q2159 -X110	TM2LP	
-Q2159 -X120	TM2LP	
-Q2159 -X130	TM2LP	
-Q2159 -X140	TM2LP	
-Q2159 -X150	TM2LP	
-Q2159 -X160	TM2LP	
-Q2159 -X170	TM2LP	
-Q2159 -X180	TM2LP	
-Q2159 -X190	TM2LP	
-Q2452-X	TMDID	
-Q2286 -X	TMLRB	
-Q2186 -X100	TMLRB	
-Q2216 -X	DIU2U	
-Q2214 -X100	TMOM2	
-Q2288 -X	TMCOW	
-Q2288 -X10	TMCOW	
-Q2288 -X20	TMCOW	
-Q2288 -X40	TMCOW	
-Q2288 -X50	TMCOW	
-Q2288 -X60	TMCOW	
-Q2288 -X100	TMCOW	
-Q2288 -X120	TMCOW	
-Q2288 -X130	TMCOW	
-Q2288 -X310	TMCOW	
-Q2292 -X100	TMEW2	
-Q2476 -X	TM3WO	
-Q2477 -X	TM3WI	
-Q2469 -X	TMEMUS	
-Q2485-X	TMC16	

### 9.5.2.1 Connecting the Trunk Modules to the MDF

Table 6 lists the trunk module connections to the MDF.

**Table 25: Connection to MDF**

..... Trunk Circuits .....																							
ID/ Part No.	HW ID	Dial Mode				Range				Type of Operation				per a/b mod per Circuit									
S30810-		DTI	DP	DP	2.W	Damping				Remarks													
		or	1.6:	2:1		IL = Long cable																	
		MF				kL = Short cable																	
MDF cable a/b no., circuit no. per module, wire identification per circuit																							
1	2	3	4	5	6	7	8	9	10	11	12	13	14	15	16	17	18	19	20	21	22	23	24
TMEM	021XH					X			2 x 1000 Ohm													4	3
-Q2012 -									-3.5/-3.5 dBr														
X100																							
1	2	3	4	1	2	3	4	1	2	3	4	-	-	-	-								
---	---	---	---	---	---	---	---	---	---	---	---	---	---	---	---	---	---	---	---	---	---	---	---
ka	ka	ka	ka	ga	ga	ga	ga	E	E	E	E												
kb	kb	kb	kb	gb	gb	gb	gb	M	M	M	M												
TMEW2	029XH	DTMF	X	X				2 x 1000 Ohm														4	4
-Q2292 -																							
X100																							
1	2	3	4	1	2	3	4	1	2	3	4	1	2	3	4	-							
---	---	---	---	---	---	---	---	---	---	---	---	---	---	---	---	---	---	---	---	---	---	---	---
AE	AE	AE	AE	AM	AM	AM	AM	E	E	E	E	MA	MA	MA	MA	<--							
BE	BE	BE	BE	BM	BM	BM	BM	M	M	M	M	MB	MB	MB	MB	Standard							
---	---	---	---	---	---	---	---	---	---	---	---	---	---	---	---	---	---	---	---	---	---	---	---
T	T	T	T	T1	T1	T1	T1	E	E	E	E	-	-	-	-	<--							
R	R	R	R	R1	R1	R1	R1	M	M	M	M	-	-	-	-	Type I							
---	---	---	---	---	---	---	---	---	---	---	---	---	---	---	---	---	---	---	---	---	---	---	---
Fan	Fan	Fan	Fan	Fab	Fab	Fab	Fab	-	-	-	-	-	-	-	-	<--							
A	A	A	A	A	A	A	A	San	San	San	San	-	-	-	-	Type Ia							
B	B	B	B	B	B	B	B	Sab	Sab	Sab	Sab	-	-	-	-								
---	---	---	---	---	---	---	---	---	---	---	---	---	---	---	---	---	---	---	---	---	---	---	---
T	T	T	T	T1	T1	T1	T1	E	E	E	E	M	M	M	M	<--							
R	R	R	R	R1	R1	R1	R1	SG	SG	SG	SG	SB	SB	SB	SB	Type II							

**External Cabling Assemblies**

..... Trunk Circuits .....																							
ID/ Part No.	HW ID	Dial Mode				Range				Type of Operation								per a/b mod per Circuit					
S30810-		DTMF	DP	DP	2.W	Damping				Remarks													
		or	1.6: 2:1			IL = Long cable																	
		MF				kL = Short cable																	
MDF cable a/b no., circuit no. per module, wire identification per circuit																							
1	2	3	4	5	6	7	8	9	10	11	12	13	14	15	16	17	18	19	20	21	22	23	24
TMLBL	43AXH	DTMF				2 x 9 KOhm				Local battery bi-directional COFI								8	1				
-Q2123 -X	436XH					-7/-0 dB				No direct inward dialing (DID)													
-X100						IL: -0/-7 dB																	
						kL: -5/-2 dB																	
						-7/-0 dB																	
1	2	3	4	5	6	7	8																
---	---	---	---	---	---	---	---	---															
a	a	a	a	a	a	a	a	a															
b	b	b	b	b	b	b	b	b															
TMLR	0A5XH	DTMF				2 x 1000 Ohm				Tie-line circuit - direct current loop								2	1				
-Q2064 -						depending on				Bi-directional SICOFI													
X100						remote system;																	
1	-	2	-																				
---	---	---	---	---																			
a		a																					
b		b																					
TMOM2	051XH	DTMF				a/b > 17 mA				APSE QUAD-SICOFI								4	3				
-Q2214 -						max. 2 x 500 / 1000				(adapter for special equipment)													
X100						Ohm				Paging equipment, dictation													
						(depending on				equipment, TERM, ELA, NWS,													
						partner)				announcement equipment, QU,													
						c-wire max.				and outgoing loop monitoring													
						200Ohm																	
						(with 3-wire																	
						connection)																	
						-0/-7 dBr																	
1	3	2	4	1	1	2	2	3	3	4	4												
---	---	---	---	---	---	---	---	---	---	---	---	---	---	---	---	---	---	---	---	---	---	---	---
a	a	a	a	J	D	J	D	J	D	J	D												
b	b	b	b	P	C	P	C	P	C	P	C												

..... Trunk Circuits .....																								
ID/ Part No.	HW ID	Dial Mode			Range			Type of Operation			per a/b mod per Circuit													
S30810-		DTMF	DP	DP	2.W	Damping			Remarks															
		or	1.6:	2:1		IL = Long cable																		
		MF				kL = Short cable																		
MDF cable a/b no., circuit no. per module, wire identification per circuit																								
1	2	3	4	5	6	7	8	9	10	11	12	13	14	15	16	17	18	19	20	21	22	23	24	
TMSFP	43BXH	DTMF	X						-4.0/-4.0 dBr													8	2	
-Q2147 -X	43EXH	*)	*)						-3.5/-3.5 dBr													4Dr		
-x300	43FXH								:															
-x400									-6.0/-1.0 dBr															
									-7.0/-0.0 dBr															
1	1	2	2	3	3	4	4	5	5	6	6	7	7	8	8									
---	---	---	---	---	---	---	---	---	---	---	---	---	---	---	---									
Fan	Fab	Fan	Fab	Fan	Fab	Fan	Fab	Fan	Fab	Fan	Fab	Fan	Fab	Fan	Fab	Fan	Fab	Fan	Fab	Fan	Fab	Fan	Fab	
AE	AM	AE	AM	AE	AM	AE	AM	AE	AM	AE	AM	AE	AM	AE	AM	AE	AM	AE	AM	AE	AM	AE	AM	
BE	BM	BE	BM	BE	BM	BE	BM	BE	BM	BE	BM	BE	BM	BE	BM	BE	BM	BE	BM	BE	BM	BE	BM	
0	0	1	1	2	2	3	3	4	4	5	5	6	6	7	7									

9.5.2.2 Connection to MDF with DID

Table 9-3 lists the trunk connections to the MDF with DID.

External Cabling Assemblies

Table 26: Connection to MDF with DID

..... Trunk Circuits .....																										
ID/ Part No.	HW ID	Dial Mode				DID	Range	Type of Operation																	per a/b mod per Circuit	
S30810-		DTMF	DP	DP	2.W		Damping	Remarks																		
		or	1.6:	2:1			IL = Long cable																			
		MFC						kL = Short cable																		
MDF cable a/b no., circuit no. per module, wire identification per circuit																										
1	2	3	4	5	6	7	8	9	10	11	12	13	14	15	16	17	18	19	20	21	22	23	24			
TMLRB -Q2286 -X	460XH								DP, DTMF, MFC R2; Socotel		2 x 1000 Ohm													8	1.5	
												IL: -8/+2 dBr														
												kL: -5/-1 dBr														
												IL: -7.9/-2.9 dBr														
												kL: -4.9/-5.9 dBr														
												-5/-2 dBr														
1	2	3	4	5	6	7	8	1	3	5	7															
---	---	---	---	---	---	---	---	---	2	4	6	8														
a	a	a	a	a	a	a	a	---	---	---	---															
b	b	b	b	b	b	b	b	bu	bu	bu	bu															
								bu	bu	bu	bu															
TM3WI -Q2477 -X	EEFXH	DTMF	X																					4	1	
												2 x 1500 Ohm														
												- 3.5/ -1 dBr														

..... Trunk Circuits .....																								
ID/ Part No.	HW ID	Dial Mode			DID	Range	Type of Operation																per a/b mod per Circuit	
S30810-		DTI	DP	DP	2.W		Damping	Remarks																
		or	1.6:	2:1			IL = Long cable																	
		MF					kL = Short cable																	
MDF cable a/b no., circuit no. per module, wire identification per circuit																								
1	2	3	4	5	6	7	8	9	10	11	12	13	14	15	16	17	18	19	20	21	22	23	24	
1	-	1	-	2	-	2	-	3	-	3	-	4	-	4	-									
---	---	---	---	---	---	---	---	---	---	---	---	---	---	---	---	---								
a		c		a		c		a		c		a		c										
b				b				b				b												

9.5.2.3 Connecting to the MDF with CDR and DID

Table 7 lists the trunk connections to the MDF with CDR and DID.

External Cabling Assemblies

Table 27: Connection to the MDF with CDR and DID

..... Trunk Circuits .....																									
Name / Part No.	HW ID	Dial Mode for CO								CDR				DID		Range Damping		Type of Operation	Remarks		per a/b	mo	per circuit		
S30810-		DTI	DP	DP	2.W	50	12	16	Sil							IL = Long cable									
		or	1.6:	2:1		Hz	kHz	kHz	Rev							kL = Short cable									
		MF																							
MDF cable a/b no., circuit no. per module, wire identification per circuit																									
1	2	3	4	5	6	7	8	9	10	11	12	13	14	15	16	17	18	19	20	21	22	23	24		
TM2LP	480XH	X	X	X	X	X	X	X	X	X	X	X	DID						AS	QSI	COFI	8	1		
-Q2159 -	481XH	X	X	X	X	X	X	X	X	X	X	X	DID						MSI						
X100	482XH	X	X	X	X	X				X	X	X	DID/						MSI						
X110	483XH	X	X	X	X	X					X		DOD						MSI						
X120	484XH	X	X	X	X	X					X								MSI						
X130	485XH	X	X	X	X														MSI						
X140	486XH																								
X150	487XH																								
X160																									
X170																									
X180																									
1	2	3	4	5	6	7	8	1	3	5	7														
---	---	---	---	---	---	---	---	---	2	4	6	8													
a	a	a	a	a	a	a	a	a	---	---	---	---													
b	b	b	b	b	b	b	b	b	bu	bu	bu	bu													
										bu	bu	bu	bu												

9.5.2.4 Connecting to the MDF with CDR but without DID

Table 8 lists the trunk connections to the MDF with CDR but without DID.

**Table 28: Trunk connection to the MDF with CDR but without DID**

..... Trunk Circuits .....																							
ID/ Part No.	HW ID	Dial Mode for CO			CDR				Range				Type of Operation				per a/b Mo per Circuit						
S30810-		DTI	DP	DP	2.W	50	12	16	Sil	IL = Long cable													
		or 1.6: 2:1				Hz	kHz	kHz	Rev	kL = Short cable													
		MF(																					
MDF cable a/b no., circuit no. per module, wire identification per circuit																							
1	2	3	4	5	6	7	8	9	10	11	12	13	14	15	16	17	18	19	20	21	22	23	24
TMCOW	450XH	X	X			X	X	X	X	X	X	X	2x185-530Ohm	DUAL-SICOFI				8	1				
-Q2288	-X 451XH	X	X			X		X	X	X	X	(J = 20 mA)	Trunk circuit										
-X10	452XH	X	X							X	X	kL: -5/-2 dB	MSI										
-X20	454XH	X	X							X	X	IL: -7/0 dB	Without DID										
-X40	45CXH	X	X							X	X	IL: -6/-1 dB	Incoming and										
-X50	458XH	X	X							X	X	kL: -4/-3 dB	Outgoing										
-X60	459XH	X	X							X		Â# -3/-4 dB	Loop start										
-X120	45AXH	X	X							X		Â,, -4/-3 dB	Ground start										
-X130	457XH	X	X							X		Â, -4.5/-2.5 dB	Loop monitoring										
-	45FXH	X	X							X		-7/0 dB	changing										
X310													0/-7 dB										
													-5/-2 dB										
													-7/0 dB	Â# = 4 different									
													-5/-2 dB	Â# = 2 different									
													-6/0 dB (Austr)	Impedance combinations									
													-9/3 dB (Austr)										
													-5/-2 dB (ITL)										
													-6/-1 dB (ITL)										
													-5.75/-IL: -8 / +2										
1	2	3	4	5	6	7	8																
---	---	---	---	---	---	---	---																
a	a	a	a	a	a	a	a																
b	b	b	b	b	b	b	b																

## External Cabling Assemblies

Creating a Strapping List, I.M.

..... Trunk Circuits .....																							
ID/ Part No.	HW ID	Dial Mode for CO											CDR	Range Damping				Type of Operation Remarks				per a/b Moc per Circuit	
S30810-		DTI	DP	DP	2.W	50	12	16	Sil	IL = Long cable													
		or	1.6:	2:1		Hz	kHz	kHz	Rev	kL = Short cable													
		MF																					
MDF cable a/b no., circuit no. per module, wire identification per circuit																							
1	2	3	4	5	6	7	8	9	10	11	12	13	14	15	16	17	18	19	20	21	22	23	24
TMLRB	561XH	X			X								1400 Ohm				DUAL-SICOFI				8	1	
-Q2186 -													-6 / -1 dBr				Trunk circuit with						
X100																	DID						
																	BPO loop signal.						
																	Ground signal						
																	recognition						
1	2	3	4	5	6	7	8																
---	---	---	---	---	---	---	---																
a	a	a	a	a	a	a	a																
b	b	b	b	b	b	b	b																

## 9.6 Creating a Strapping List, I.M.

To create a list of all positions that are necessary in the MDF:

- 1) Use the tables in [Section 9.6.1, System Assignment 16/24 DA Splitting Strip](#) and [Section 9.6.2, Network Assignment 25/35 DA Strapping Connector](#) as templates to strapping the MDF. You can also query the assignment of positions with the AMOs SBCSU and SCSU.
- 2) Include these lists with the customer documentation. These are the current working documents for activities performed on the MDF.

### 9.6.1 System Assignment 16/24 DA Splitting Strip

BGR	a-
SLOT	b
/P	
Pin47/	24
(a/ 48	
b) 45/	23
46	

43/	22
44	
41/	21
42	
39/	20
40	
37/	19
38	
35/	18
36	
33/	17
34	
31/	16
32	
29/	15
30	
27/	14
28	
25/	13
26	
23/	12
24	
21/	11
22	
19/	10
20	
17/	9
18	
15/	8
16	
13/	7
14	
11/	6
12	

## External Cabling Assemblies

9 /																	5
10																	
7 /																	4
8																	
5 /																	3
6																	
3 /																	2
4																	
1 /																	1
2																	
MDF	C	C	C	C	C	C	C	C	C	C	C	C	C	C	C	C	Da
SLOT	016	015	014	013	012	011	010	009	008	007	006	005	004	003	002	001	

### 9.6.2 Network Assignment 25/35 DA Strapping Connector

Pin69/ (a/ b) 70
67/
68
65/
66
63/
64
61/
62
59/
60
57/
58
55/
56
53/
54

51/
52
49/
50
47/
48
45/
46
43/
44
41/
42
39/
40
37/
38
35/
36
33/
34
31/
32
29/
30
27/
28
25/
26
23/
24
21/
22
19/
20

## External Cabling Assemblies

17/

18

15/

16

13/

14

11/

12

9 /

10

7 /

8

5 /

6

3 /

4

1 /

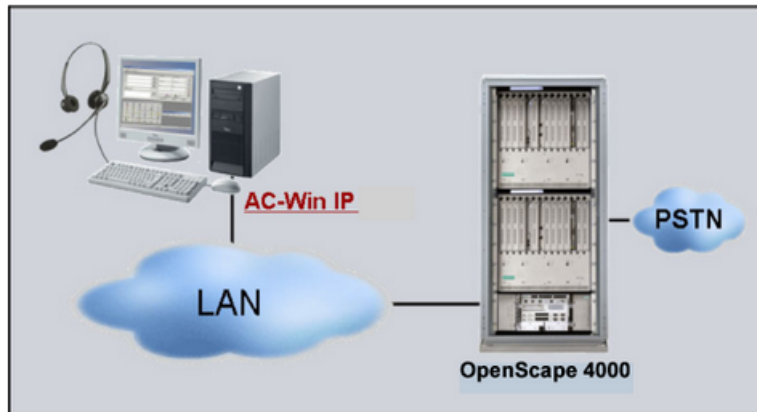
2

Slot - 0016 002 003 004 005 006 007 008 009 010 011 012 013 014 015 016 017 018 019  
D

## 10 Installing Peripheral Equipment

### 10.1 Installing the AC-WIN IP Attendant Console

The AC-Win IP attendant console is connected over IP to an HG3530 V2.0 in a OpenScape 4000 system. The USB device (handset and headset) is connected to the PC. Although any standard commercial PC can be used, Fujitsu-PCs have been tested and are recommended. The functionality offered is only provided via software.



---

**IMPORTANT:** For detailed information on installation and configuration, refer to the latest service manual for the AC-Win IP enhanced attendant console.

---

## 10.2 Connecting the Service Terminal

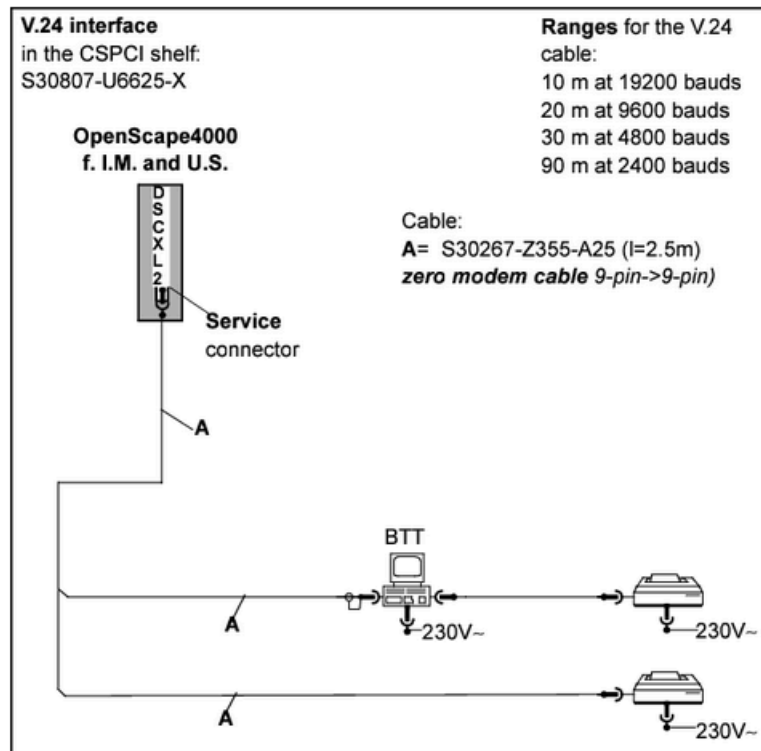


Figure 190: Service terminal connection

### 10.3 HiPath SIRA (Secured Infrastructure For Remote Access)

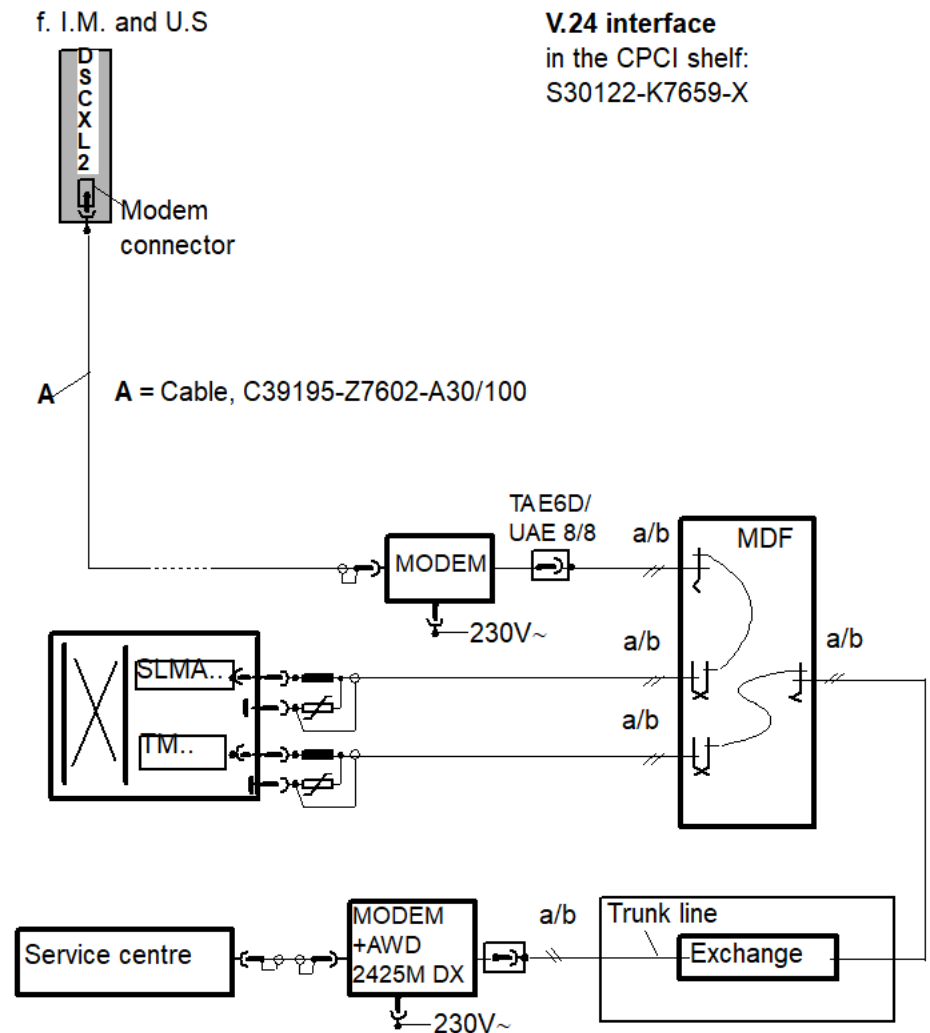


Figure 191: HiPath SIRA

### 10.4 Connecting Cables

**NOTICE:** The shield of all front cables (except network cables and optical fiber cables) must be secured to the frame with two cable ties at the shelf opening. See also [Section 4.6, Shielding Connection on the Opening of the LTU Frame](#).

#### 10.4.1 Connecting ISDN Connections

10.4.1.1 PNE/PBXXX Back-to-Back with Modem and DIUT2

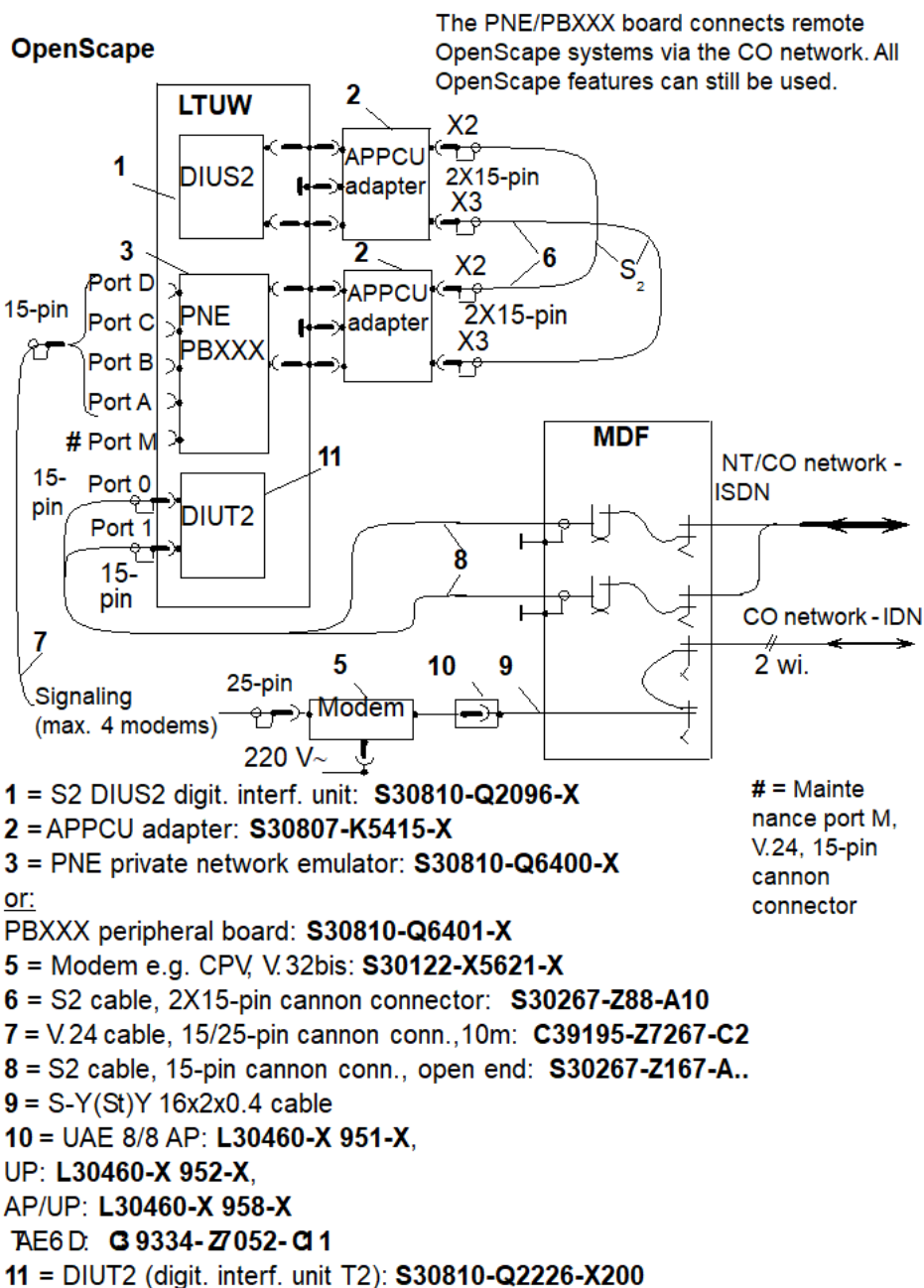
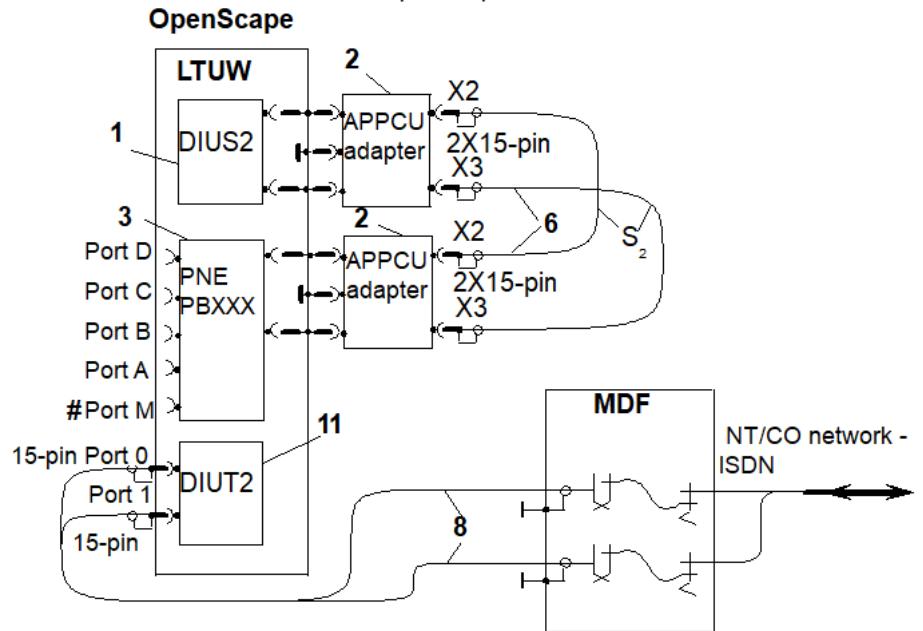


Figure 192: PNE/PBXXX back-to-back with modem and DIUT2

### 10.4.1.2 PNE/PBXXX Back-to-Back with DIUT2

The PNE/PBXXX board connects remote OpenScope systems via the CO network. All OpenScope features can still be used.



# = Maintenance port M, V.24, 15-pin cannon connector

1 = S2 DIUS2 digit. interf. unit: **S30810-Q2096-X**

2 = APPCU adapter: **S30807-K5415-X**

3 = PNE private network emulator: **S30810-Q6400-X**

or:

PBXXX peripheral board: **S30810-Q6401-X**

6 = S2 cable, 22X15-pin cannon connector: **S30267-Z88-A10**

8 = S2 cable, 15-pin cannon conn., open end: **S30267-Z167-A..**

11 = DIUT2 (digit. interf. unit T2): **S30810-Q2226-X200**

Figure 193: PNE/PBXXX back-to-back without modem and with DIUT2

10.4.1.3 PNE/PBXXX Back-to-Back with Modem in DIUS2 Emulation with DIUT2

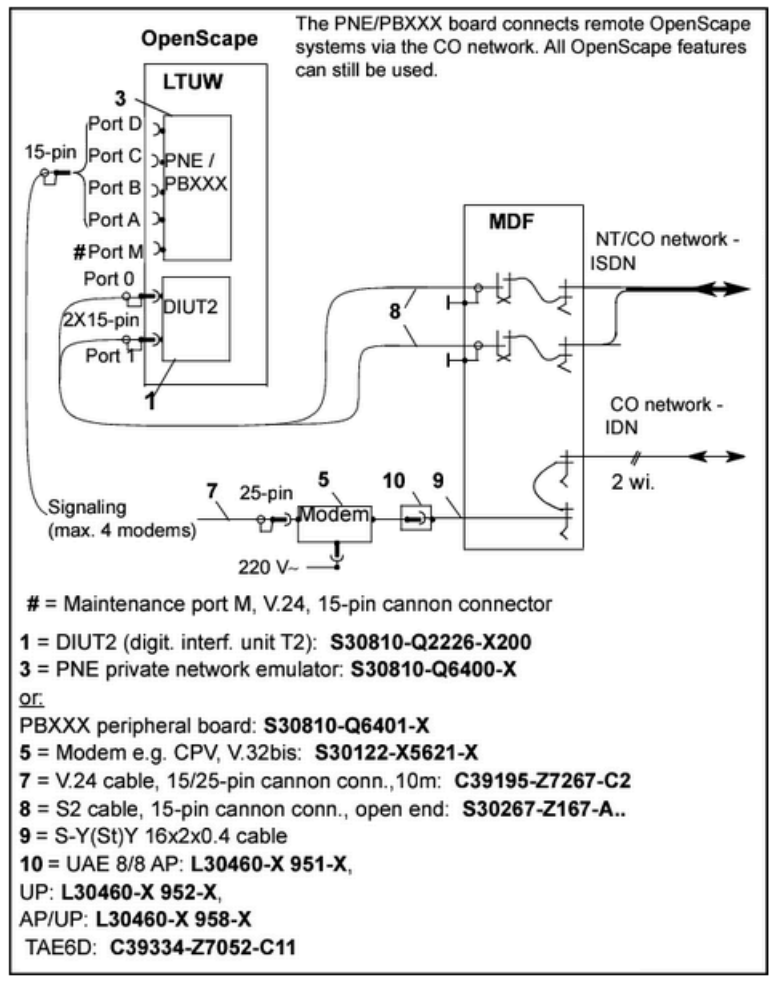


Figure 194: PNE/PBXXX back-to-back with modem in DIUS2 emulation with DIUT2

#### 10.4.1.4 PBXXX as Gateway, Fully Integrated Mode

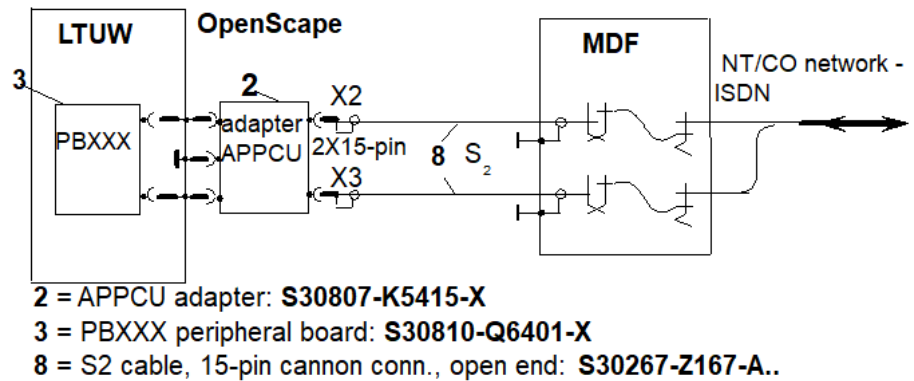


Figure 195: PBXXX as Gateway, Fully Integrated Mode

#### 10.4.1.5 PBXXX with DIUT2 as Gateway, Partially Integrated Mode

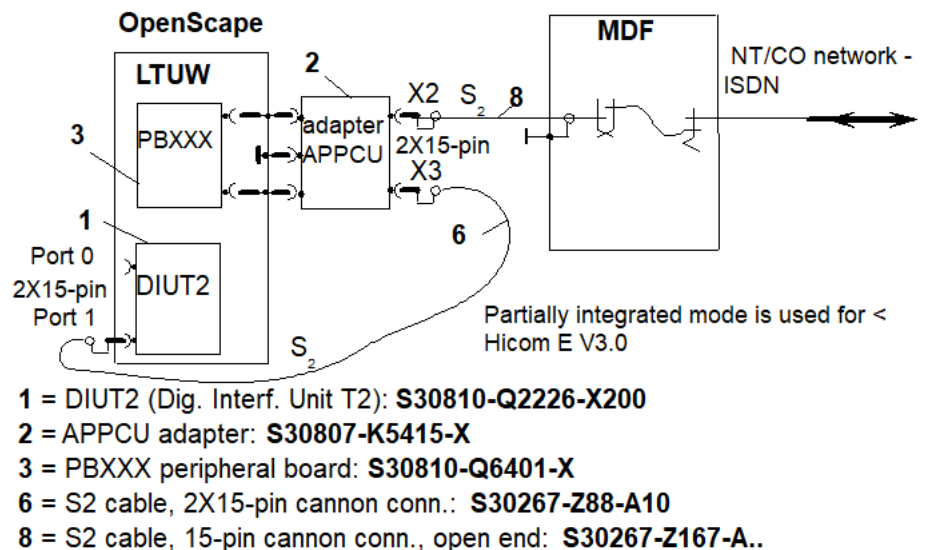


Figure 196: PBXXX with DIUT2 as Gateway, Partially Integrated Mode

### 10.5 Installing the Distance Adapter

The distance adapter converts the 2-wire U2B1Q interface of the subscriber line module 2B1Q 3 (SLMQ3) board to the UP0/E interface of the Optiset E or OptiPoint telephone.

To install the distance adapter:

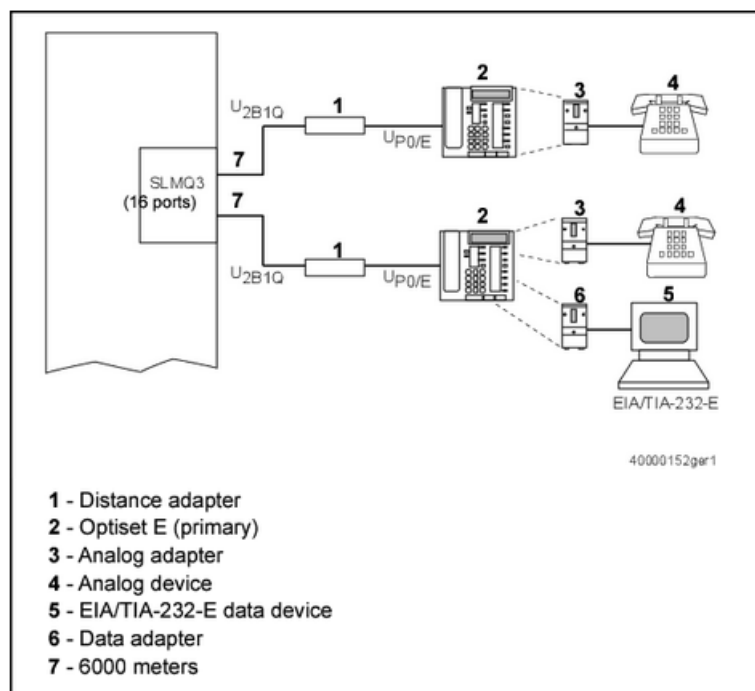
## Installing Peripheral Equipment

- 1) At the back of the distance adapter, connect one end of a line cord to the UP0/E connector (see [Figure](#) ).
- 2) Connect the other end of the line cord to the Optiset E or OptiPoint telephone.
- 3) At the back of the distance adapter, connect another line cord to the PABX U2B/1Q connector.
- 4) Connect the other end of the line cord to the MDF.
- 5) Plug the power supply into an ac outlet
- 6) At the back of the distance adapter, connect the other end of the power supply into the PS connector.

---

**IMPORTANT:** For additional information, refer to the installation instructions that are shipped with the product.

---



**Figure 197: Connectivity options for the distance adapters**

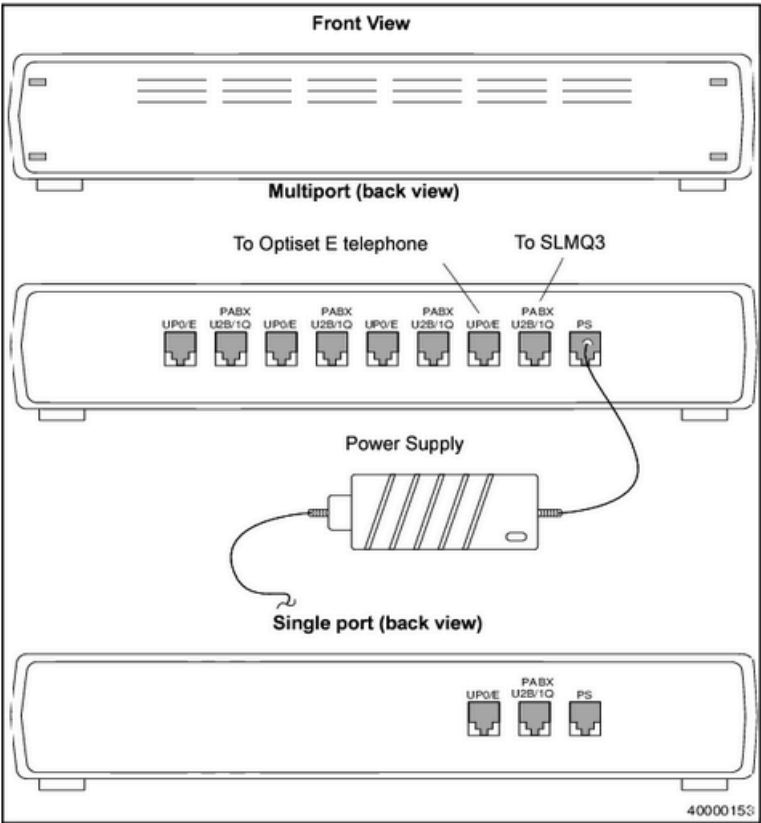


Figure 198: Distance adapter

## 11 Installing the IPDA

This chapter describes the connection of the OpenScape 4000 to the (IP Distributed Architecture) IPDA system. It also provides procedures to install the OpenScape IPDA components.

---

**IMPORTANT:** Refer to the OpenScape 4000 Service Manual for additional information about the IPDA installations (IP solutions).

---

[Figure 1 on page 300](#) shows a diagram of the OpenScape 4000/IPDA connectivity. The systems can be installed as free-standing systems or can be built into a 19-inch cabinet.

OpenScape 4300 supports up to 40 access points connected over IP (AP 3300 IP or AP 3700-9 IP) as well as up to 3 shelves that are connected directly (AP3300/AP3700-9 IP).

OpenScape 4000 facilitates the distribution of access points over an IP network. These access points are shelves (AP3300 IP or AP3700-9 IP) that accommodate standard OpenScape 4000 interface modules. The stations at the access points are treated exactly the same way as if they were directly connected to a OpenScape 4000 system as before. All IP-distributed components are administered as a single system over one OpenScape 4000 system connection point.

The system consists of a maximum 4 stacks (AP 3300 IP only) and one power management unit attached to each other in a single row. The system can be placed anywhere in the room (maximum expansion of 15 LTUW = 5760 ports). Each stack can be configured with up to 4 boxes. The stacks are permanently connected. A maximum of 6 wall main distribution frames (MDFHX6) can be used. This corresponds to expansion up to a maximum 2304 ports.

Cabling should only be configured underfloor (double floor). The reference point for system cabling is located at the lower end of the stack (see [Figure 7](#)).

The system can also be configured using IPDA instead of one single stack (maximum of four boxes for every stack). These systems can be installed as free-standing systems or can be built into a 19-inch cabinet.

OpenScape 4500 supports up to 83 IP-connected access points (AP 3300 IP or AP 3700/9 IP) in addition to up to 15 directly connected module frames (AP 3300).

OpenScape 4000 also facilitates the distribution of access points over an IP network. These access points are frames (AP 3300 IP or AP 3700/9 IP) that include standard OpenScape 4000 interface modules. User connection to access points is identical to standard, direct connection to a OpenScape 4000 system. Administration of all IP-distributed components is carried out as a single system using a OpenScape 4000 system connection point.

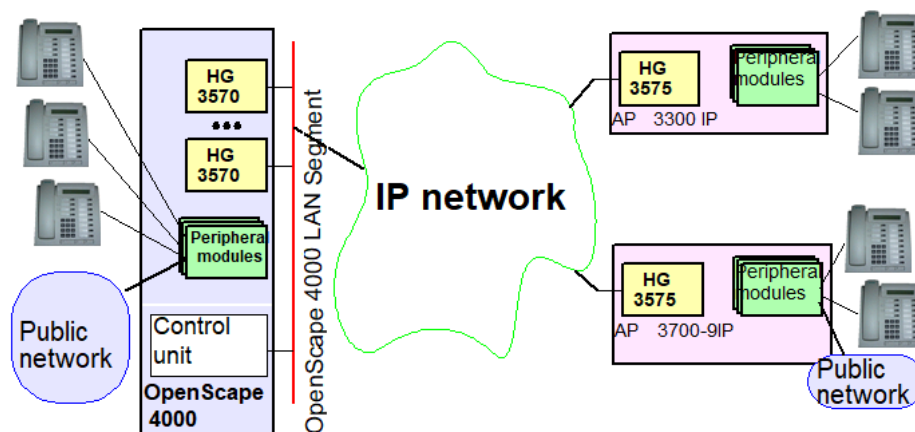


Figure 199: System architecture overview

---

**NOTICE:** Each cabinet, including the front cover, forms a shielded unit. Ensure to lock the cabinets while the system is running and replace the covers immediately following testing and maintenance.

---

## 11.1 IPDA Connection Variants

### 11.1.1 Connecting to AP 3700-9 IP

This section describes possible connections for IPDA system installations: OpenScape 4000 permits you to use both existing AP 3300 cabinets (L80XF) and the new AP 3700 IP cabinets (AP 3700-9 IP) as IPDA frames (see [Figure 2 on page 301](#)).

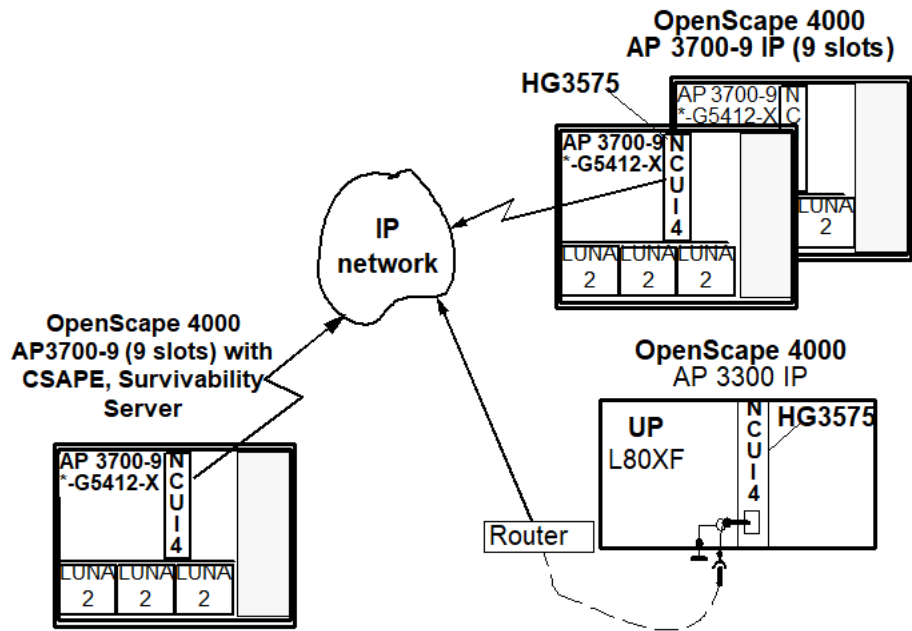


Figure 200: IPDA connection to AP 3700-9

### 11.1.2 Connecting to LTUW/L80XF

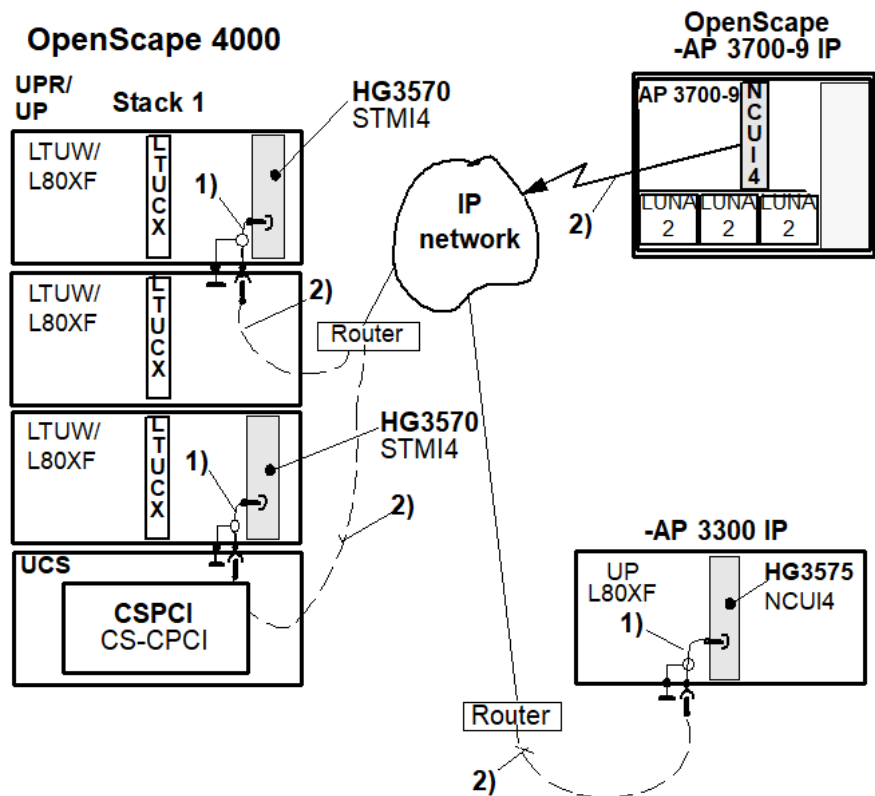


Figure 201: Connecting AP 3300 IP and AP 3700-9 to LTUW/L80XF

## 12 Starting the System

This chapter describes the commissioning and startup of the OpenScape 4000 system.

### 12.1 Completing the Installation

Once you have completed the installation process, double-check the items in [Table](#) .

**Table 29: Post-installation checklist**

Step	Check	Completed?
1	Screw connections secure?	
2	Grounding system connected correctly (system/MDF)? See <a href="#">Chapter 6, "Grounding the OpenScape 4000"</a> .	
3	Mains connection protected by fuses?	
4	Power supply connected correctly (internal/external)?	
5	Cable connectors secure? See <a href="#">Section 12.2.2, Checking the Signal Cable Connections</a> .	
6	Cables laid correctly (with cable grips)? Refer to <a href="#">Chapter 8, "Internal Line Cables"</a> and <a href="#">Section ,External Cabling Assemblies"</a> .	
7	MDF layout plan completed?	
8	Covers replaced correctly (necessary only if the system is not started immediately after installation)? See <a href="#">Section 12.14, Replacing the Covers</a> .	
9	Documentation assembled and handed over to the customer?	

See also the official checklist for our quality management "Checklist for finalizing assembly work", which can be found in the partner portal and is supplied additionally with every product.

Before concluding assembly work on a OpenScape 4000, please check whether the questions can all be answered unequivocally withyes".

### 12.2 Pre-Power On Checks

Perform the following procedures before you apply power to the system.

## Starting the System

Turning on a Nonredundant AC-Powered OpenScape 4000

### 12.2.1 Reseating the Boards

---

**IMPORTANT:** Do not use ESD procedures when working with power supplies. If any power supplies becomes unseated during transport, reseat it by gently pushing it toward the backplane until it seats in place.

---

If any board becomes unseated during transport, reseat it as follows:

- 1) Follow the electrostatic discharge prevention procedures.
- 2) Insert the peg of the board removal tool into the hole at the top of the unseated board.
- 3) Lift the board removal tool and completely unseat the board.
- 4) Remove the board removal tool.
- 5) Gently push the board toward the backplane until it seats in the backplane connector.

### 12.2.2 Checking the Signal Cable Connections

LTU shelf signal cables are signal cables that originate at the LTU shelf backplane.

To ensure that all signal cable connections are secure:

- 1) Check that all signal cables are tightly secured at the connector on each shelf backplane.
- 2) Check that the connectors on the other end of the signal cables are tightly secured.
- 3) If signal cables were disconnected during transit, refer to the hardware map to connect and secure these cables to the proper locations.

### 12.2.3 Checking the Power Distribution Cable Connections

The system is shipped with the power distribution cables already connected to the backplane. These cables may become disconnected during transit. To check that the power distribution cable connections in each cabinet:

- 1) Check for loose or disconnected power distribution cable connections at the backplanes.
- 2) If there are any loose or disconnected power distribution cable connections, refer to the hardware map to connect and secure these cables to the proper locations.

## 12.3 Turning on a Nonredundant AC-Powered OpenScape 4000

To turn on a nonredundant ac-powered OpenScape 4000:



---

**WARNING:** Observe all applicable safety precautions when working with high voltages.

---

- 1) Remove the tie-wrap from the power cord and uncoil.
- 2) Plug the ac power cord to the wall outlet.
- 3) Plug the other end of the ac power cord to the LPC80.
- 4) Turn on the power switch on the LPC80.
- 5) Turn on the power switch on the PSUP.

## 12.4 Turning on Cabinet 1 and 2 of a Redundant AC-Powered OpenScape 4000

To turn on cabinet 1 of an ac-powered OpenScape 4000:



**WARNING:** Observe all applicable safety precautions when working with high voltages.

- 1) Plug in the OpenScape 4000 power cord to the wall outlet.
- 2) At the back of the cabinet: Turn on the main circuit breaker under the CSPCI shelf (see [Figure 2 on page 309](#)).
- 3) At the ACDPX board in UACD stack 1: Turn on the ac input power switches.
- 4) At the PDPX2 terminal field in UACD stack 1: Turn on the ac output power module (PM1, PM2, and PM3) circuit breakers.
- 5) At the PDPX2 terminal field in UACD stack 1: Turn on the circuit breakers for the 48-V trunks (BULK and TALK).
- 6) At the back of UACD stack 1: Turn on the backup battery circuit breaker.

**IMPORTANT:** ECCB is not used in the U.S.

- 7) Turn on the dc-to-dc shelf power supplies in the following order:
  - a) Shelf 1
  - b) Remaining dc-to-dc shelf power supplies
- 8) At the PDPX2 terminal field in UACD stack 1: Turn on the power share circuit breaker.

## 12.5 Turning on Cabinet 3 and 4 of a Redundant AC-Powered OpenScape 4000

To turn on cabinet 3 of an ac-powered OpenScape 4000:



**WARNING:** Observe all applicable safety precautions when working with high voltages.

- 1) Plug in the OpenScape 4000 power cord to the wall outlet.
- 2) At the back of the cabinet: Turn on the main circuit breaker under the CSPCI shelf (see [Figure](#)).
- 3) At the ACDPX board in UACD stack 2: Turn on the ac input power switches.
- 4) At the PDPX2 terminal field in UACD stack 2: Turn on the ac output power module (PM1, PM2, and PM3) circuit breakers.
- 5) At the PDPX2 terminal field in UACD stack 1: Turn on the 48-V circuit breakers (BULK and TALK).

## Starting the System

### Turning on Cabinet 1 of a DC-Powered OpenScape 4000

- 6) At the back of UACD stack 2: Turn on the backup battery circuit breaker.

---

**IMPORTANT:** ECCB is not used in the U.S.

---

- 7) Turn on the dc-to-dc shelf power supplies in the following order:
  - a) Shelf 1
  - b) Remaining dc-to-dc shelf power supplies
- 8) At the PDPX2 terminal field in UACD stack 2: Turn on the power share circuit breaker.

## 12.6 Turning on Cabinet 1 of a DC-Powered OpenScape 4000

To turn on cabinet 1 of a dc-powered OpenScape 4000:

- 1) At the dc system switchboard: Turn on and tag off the circuit breaker for the dc electric circuit in cabinet 1.
- 2) At the back of cabinet 1 (under the CSPCI shelf): Turn on the main circuit breaker (see [Figure 2](#)).
- 3) At the ICBP field in the UDCD cabinet in stack 1: Turn on the PMOD power switches (see [Figure 1](#)).
- 4) Turn on the cabinet 1 dc-to-dc shelf power supplies in the following order:
  - a) Shelf 1 (CSPCI shelf, cabinet 1)
  - b) Remaining dc-to-dc shelf modules
- 5) At the front of UDCD cabinet 1 stack 1 ODP ([Figure](#)): Turn on the -48-V TALK circuit breaker.



1

**Figure 202: ICBP**

## 12.7 Turning on Cabinet 2 of a DC-Powered OpenScape 4000

To turn on cabinet 2 of a dc-powered OpenScape 4000:

- 1) At the dc system switchboard: Turn off and tag off the circuit breaker for cabinet 2.
- 2) At the back of cabinet 2 (under the CSPCI shelf): Turn on the main circuit breaker (see [Figure](#) ).
- 3) At the ICBP field in UDCD cabinet 1 in stack 2: Turn on the PMOD power switches (see [Figure](#) ).
- 4) At the front of UDCD cabinet 1 stack 2 ODP: Turn on the -48-V BULK circuit breaker (see [Figure](#) ).

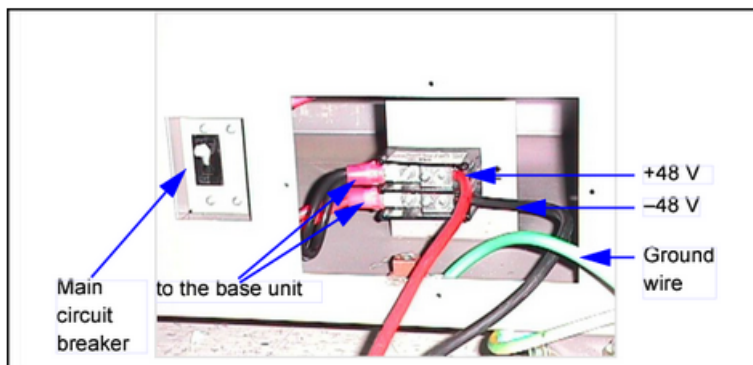


**Figure 204: Output distribution panel, front view**

In cabinet 2 in the OpenScape 4000 system: Turn on the dc-to-dc shelf power supplies in the following order:

- a) Shelf 1, (CSPCI shelf, cabinet 2)
- b) Remaining dc-to-dc shelf power supplies
- 5) At the front of UDCD cabinet 1 stack 2 ODP: Turn on the -48-V TALK circuit breaker (see [Figure](#) ).

1



**Figure 203: Main circuit breaker, OpenScape 4000, rear view**

## Starting the System

Turning on Cabinet 3 of a DC-Powered OpenScape 4000

### 12.8 Turning on Cabinet 3 of a DC-Powered OpenScape 4000

To turn on cabinet 3 of a dc-powered OpenScape 4000:

- 1) At the dc system switchboard: Turn off and tag off the circuit breaker for cabinet 3.
- 2) At the back of cabinet 3 (under the CSPCI shelf): Turn on the main circuit breaker.
- 3) At the ICBP field in UDCD cabinet 2 in stack 1: Turn on the PMOD power switches.
- 4) In cabinet 3 in the OpenScape 4000 system: Turn on the dc-to-dc shelf power supplies in the following order:
  - 5) Shelf 1 (CSPCI shelf, cabinet 1)
  - 6) Remaining dc-to-dc shelf power supplies
- 7) At the front of UDCD cabinet 2 stack 1 ODP: Turn on the -48-V TALK circuit breaker.

### 12.9 Turning on Cabinet 4 of a DC-Powered OpenScape 4000

To turn on cabinet 4 of a dc-powered OpenScape 4000:

- 1) At the dc system switchboard: Turn off and tag off the circuit breaker for cabinet 4.
- 2) At the back of cabinet 4 (under the CSPCI shelf): Turn on the main circuit breaker.
- 3) At the ICBP field in UDCD cabinet 2 in stack 2: Turn on the PMOD power switches.
- 4) At the front of UDCD cabinet 2 stack 2 ODP: Turn on the -48-V BULK circuit breaker.
- 5) In cabinet 4 in the OpenScape 4000 system: Turn on the dc-to-dc shelf power supplies in the following order:
  - 6) Shelf 1, (CSPCI shelf, cabinet 1)
  - 7) Remaining dc-to-dc shelf power supplies
- 8) At the front of UDCD cabinet 2 stack 2 ODP: Turn on the 48-V TALK circuit breaker (see [Figure 3](#)).

### 12.10 Setting the Date and Time

The system time is needed for all central messages and is output to all digital terminals. Set the current date and time using the system software or the AMO DATE.

---

**IMPORTANT:** Expect a time delay until the digital terminals have accepted the change (time/date). The change (time/date) is only implemented on the attendant console when you remove and then reinsert the handset cord.

---

## 12.11 Installation Processes

For information on the installation processes, as well as more Best Practice processes, please see the "Best Practice Installation Process" document, which can be found in the partner portal:

## 12.12 Starting the System

When you start the OpenScape 4000 system (PABX), use the OLED (organic LED) display or the LEDs to identify the different load states that are reached. These displays can help you check the PABX start up errors, if any.

---

**NOTICE:** If the system is brought into the equipment room from a cold environment, condensation may occur. Wait until the system temperature is balanced and the system is completely dry before starting it up.

---

To perform a startup:

---

**NOTICE:** If the customer HD has not been generated, it must first be generated (e.g. in the Generation Center) and then swapped with the test database. If a generated customer HD is available, replace the test database in the system with the generated customer HD.

---

- 1) Ensure that the plug has been ECOS-tested for safety purposes.
- 2) Plug the hardware to the power supply.
- 3) Depending on the BIOS settings, the hardware will auto start-up or the power button needs to be pressed.

## 12.13 Replacing the Covers

Replace the individual covers when the system has been fully mounted, cabled, and put into operation. The covers are replaced in the reverse order to the order in which they were removed.

---

**IMPORTANT:** Each cabinet, including the front cover, forms a shielded unit. Ensure to lock the cabinets while the system is running and replace the covers immediately following testing and maintenance.

---

- 1) Replace the covers starting with the lower cabinets.
- 2) Lock the top cover by turning the quick-release 90° to the left or right (1) until the covers are firmly secured.



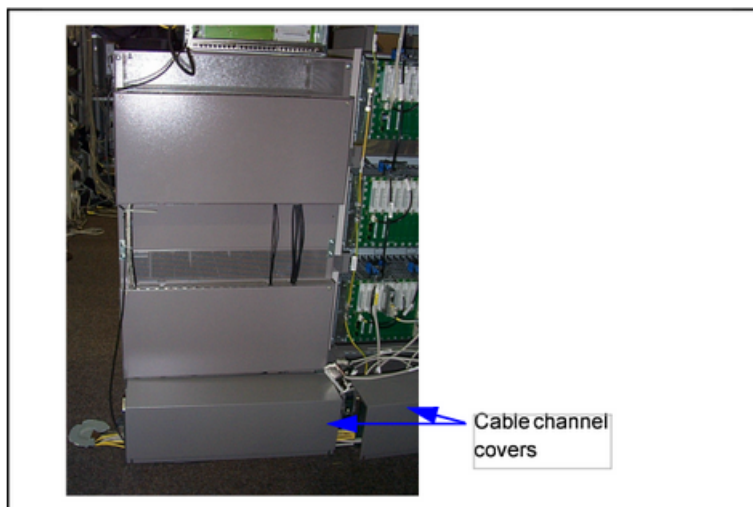
---

**CAUTION:** Risk of injury from falling unlocked covers. The covers are secure when you hear a click as you shut the cover. The cover may fall off if it is not locked into place.

---

## Starting the System

- 3) Install the cover to the cable channel (see [Figure](#)).



**Figure 205: Installing the Cable Channel Covers**

## 13 Verifying the System

If no guidelines or checklists regarding system verification are available, this section describes the tests and other measures that must generally be taken to ensure error-free operation of the system.

### 13.1 Tools Required

---

**IMPORTANT:** Each cabinet, including the front cover, forms a shielded unit. Ensure to lock the cabinets while the system is running and replace the covers immediately following testing and maintenance.

---

Use the following tools to perform the system verification procedures in this chapter:

- Maintenance telephone with a direct inward dialing (DID) number and direct trunk select capability enabled
- Telephone test set, P/N 66E3472 or 66E3924
- Transmission measuring test set (TMS) with singing return loss (SRL) and echo return loss (ERL) capability (SAGE 930A with options 01 and 10C), P/N 66E4280

---

**IMPORTANT:** Perform the installation and testing procedures described below using the Hicom One Tool (HOT) or Expert Access" (for a more detailed description of these procedures refer to the Online Help for the Hicom One Tool).

---

### 13.2 Checking the Boards

To check the status of the peripheral boards, use the selected software (such as Expert Access). Peripheral boards are used in the line termination unit (such as SLMA, RG and LTUCA boards).

### 13.3 Checking the Cables

Check the assignment of the generated subscriber positions to the extensions. Test the functionality of trunk lines, tie lines, and special equipment.

- 1) Set up a tie-line (incoming/outgoing) and then initiate a consultation call.
- 2) Forward the call.
- 3) Set up a trunk (incoming/outgoing) and then initiate a consultation call.
- 4) Forward the call.
- 5) Check the line statuses using the TAP (analog circuits, digital circuits and special circuits):
- 6) Ensure that the connected lines are in the READY state.

## Verifying the System

### Checking and Testing the Features

## 13.4 Checking and Testing the Features

To check the available features using the TAP and ensure that they are functioning correctly, refer to the operating instructions for the terminals and attendant console. Test all features for functionality.

A list of abbreviations for features can be found in the OpenScope 4000 service manual under the AMO description "FEASU".

## 13.5 Testing the Restart and Failure Transfer Function

Test the restart behavior and the failure transfer function of the system using the TAP.

- 1) Test soft restart
- 2) Test hard restart.

To test the failure transfer function of the system (only with an analog trunk):

- 1) Switch off the main power supply to the system.
- 2) Test the failure transfer function on the relevant customer device.
  - Is there a dial tone from the exchange?
  - Is it possible to dial the exchange?

In the event of a power failure on the system, an analog trunk is switched on an analog device by means of a drop out relay.

- 3) After the test is complete, switch on the power to the system again (reload) and wait until it has started up.

## 13.6 Backing up the Customer Data

In order to be able to create a customer-specific hard disk as quickly as possible in the event of a hard disk failure, you must back up the program system (PS) for every customer.

Best Practice processes can be referenced in the document "Best Practice Installation Process", which can be found in the partner portal.

## 13.7 Setting and Activating the SIRA Function

SIRA (HiPath Secured Infrastructure for Remote Access) enables you to perform service tasks (such as system maintenance, troubleshooting, universal services) via the telephone network. This facility allows the product specialist to provide support remotely.

The following functions are part of SIRA:

- Remote maintenance
- Automatic fault reporting
- Software patches

For hardware and software settings, please see the service manual description, e.g. "HiPath Secured Infrastructure for Remote Access".

## 13.8 Checking the Ring Generator

To verify the ring generator, connect an ANATE to an SLMA port and dial the ANATE. If the ANATE rings like the normal U.S. cadence, it is functioning properly.

---

**IMPORTANT:** If the ANATE telephone does not ring, check the ring generator settings.

---



**WARNING:** Be extremely careful when working with the ring generator. High voltages are present at the ring generator.

---

Ensure that the ring generator is jumpered as follows before powering on the system: 85 V, 20 Hz. To check this setting:

- 1) Ensure that the system is off.
- 2) Unscrew the screw that holds the ring generator in place.
- 3) Remove the ring generator.
- 4) On the backside of the ring generator, find a black plastic flap.
- 5) Check the setting.
- 6) Refer to the diagram on the ring generator for additional information.

## 13.9 Verifying the Station-to-MDF Connections

If the MDF cabling is performed by a subcontractor, verify and document all work as follows:

- 1) Check on the progress of the subcontractor's work.
- 2) Issue or implement change orders to the subcontractor as needed.
- 3) Walk through the site to verify that the cabling has been completed according to guidelines, and either accept the work or write a list of the corrections to be made.

## 13.10 Verifying Transmission Facilities

This section describes the procedures used to verify CO and DID trunks, ISDN and T1 spans, and OPS lines and trunks.

### 13.10.1 Balancing Networks

To ensure optimum transmission performance, the TMC16, TMDID, and SLMA3 channels must be configured to the balance network that provides the best return loss (ERL and SRL). The balance network is configured by means of COFIDX field in the Direct AMO Dialog fast-path code (command) CHATCSU for TMDID, TMC16, and the NWBALNO field in command CHASCSU for OPS. A default value of 3 provides adequate performance for most trunk facilities, and OPS lines usually perform adequately with a default value of 2.

### 13.10.2 Choosing the Balance Network

For locally used trunks, the best balance network choice provides the highest ERL value that is equal to or greater than 10 dB, and an SRL low and SRL high that are equal to or greater than 10 dB. connotations

For facilities that are utilized within complex networks the best balance choice provides the highest ERL value that is equal to or greater than 18 dB and an SRL low and high that are equal to or greater than 10 dB.

---

**IMPORTANT:** Do not select a balance network if the measured ERL value is less than either of the measured SRL values.

---

Table 1 shows various sample return loss measurements. In this example the best choice balance network would be network 3. Network 2 and 5 are acceptable for local trunks. Network 4 is not acceptable.

**Table 30: Return loss measurement examples (1)**

Network	ERL (dB)	SRL Low (db)	SRL High (db)
2	13.7	10.2	11.0
3	18.6	13.2	14.5
4	6.2	5.7	6.1
5	15.7	14.1	14.3

### 13.10.3 Selecting the Balance Network

---

**NOTICE:** Use this method only when more than one balance network meets the minimum criteria set previously in [Section 13.10.2, Choosing the Balance Network](#). Do not include balance networks if the measurements fall below any of the minimum level requirements. If a trunk only meets or exceeds the minimum requirements on one balance network, then select that balance network but do not use this method.

---

To select a balance network:

- 1) Select a trunk.
- 2) Take the ERL and SRL measurements for all four networks on the selected trunk.

---

**IMPORTANT:** Compare the four network measurements in each category.

---

- 3) Assign a quality factor rank (Q number 1 to 4) number, with 4 being the best return loss measurement. Ignore the trunk if any measurement falls below minimum requirements.
- 4) List the Q number for each balance network. Select the higher Q number total. In the event that two trunks have the same Q number total, select

the network with the highest ERL measurement. If both trunks have the same ERL measurement, select the network with the highest SRL low measurement followed by the highest SRL high measurement. Network 3 (Table) shows an example of the best trunk balance network using the Q number method.

**Table 31: Return loss measurement examples (2)**

Net-work	ERL (dB)	Q-No. ERL	SRL Low (db)	Q-No. SRL Low	SRL High (db)	Q-No. SRL High	Q-No. Total
2	13.7	2	10.2	2	11.0	2	6
3	18.6	4	13.2	3	12.5	4	11
4	6.2		5.7		6.1		
5	15.7	3	14.1	4	14.3	3	10

### 13.10.3.1 Balancing CO Trunks

To determine the best central office (CO) trunk configuration, perform the following:

- 1) Set the balance network in the trunk configuration to 2 as follows:
  - a) Type the command `CHA-TCSU` and press Enter.
  - b) Enter the following values and press Enter after each:

Field	Value
PEN1	<LTG-LTU-SLOT-CIRCUIT>
DEV	<GRDSTR or LPSTR>
COFIDX	2

---

**IMPORTANT:** The angle brackets (< >) indicate fields that require trunk specific information.

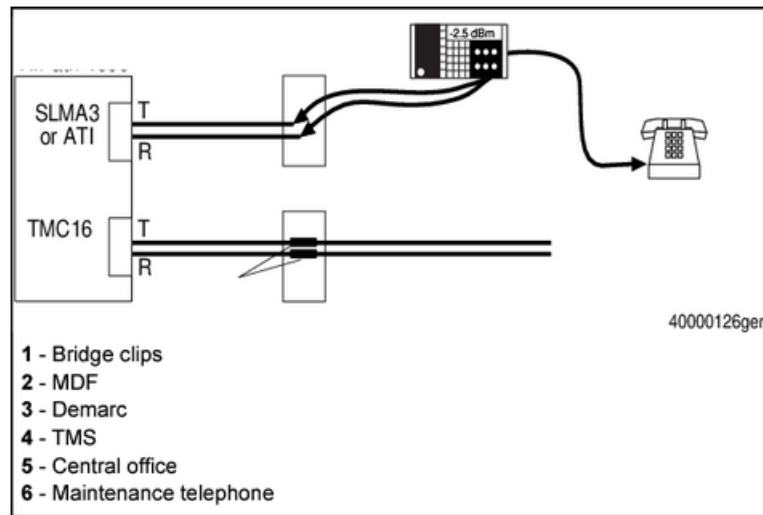
---

- 2) Activate the CO line to load the new balance network as follows:
  - a) Type the command `ACT-DSSU` and press Enter.
  - b) Enter the following values and press Enter after each:

Field	Value
ONTYPE	AUL
TYPE	PEN
PEN1	<LTG-LTU-SLOT-CIRCUIT>
PEN2	<LTG-LTU-SLOT-CIRCUIT>

- 3) Disconnect the maintenance telephone from the MDF block.

- 4) Connect the transmission test set to the maintenance telephone port (Figure 1).



**Figure 206: Test setup for measuring ERL and SRL on CO trunk channels**

- 5) Verify that the TMS is in termination mode with 600-Ohm impedance.
- 6) Direct select the trunk under test by dialing # # 8 x x x.
- 7) Listen for CO dial tone. If you cannot get dial tone, ensure that it is not in use, and then perform the CO trunk signaling tests.
- 8) Dial the silent termination number of the facility provider.
- 9) Measure and note the ERL and SRL (low and high) values.
- 10) Repeat steps 1 through 9 of this procedure for balance network configurations 3, 4, and 5.

**IMPORTANT:** In step 1, change COFIDX=2 in the command line to the correct balance network configuration number.

- 11) Configure the balance network in the trunk configuration that provided the best ERL and SRL values.

### 13.10.3.2 Balancing DID Trunks

To determine the best DID trunk configuration:

- 1) Set the balance network in the trunk configuration to 2 as follows:
  - a) Type the command `CHA-TCSU` and press Enter.
  - b) Type the following field values and confirm every input with Enter:

Field	Value
PEN	<LTG-LTU-SLOT-CIRCUIT>
DEV	DID COFIDX 2

- 2) Activate the DID line to load the new balance network as follows:
  - a) Type the command `ACT-DSSU` and press Enter.
  - b) Type the following field values and confirm every input with Enter:

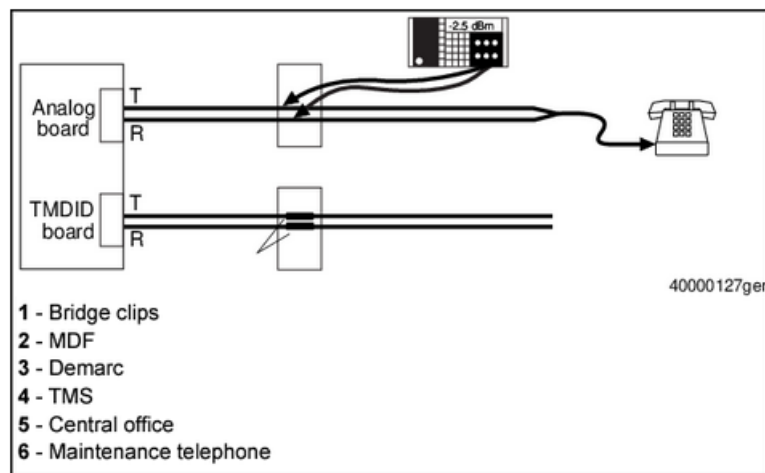
Field	Value
ONTYPE	AUL
TYPE	PEN
PEN1	<LTG-LTU-SLOT-CIRCUIT>
PEN2	<LTG-LTU-SLOT-CIRCUIT>

---

**IMPORTANT:** Steps 3 through 7 are not applicable to systems with hardware and symptom diagnosis (HSD).

---

- 3) Disconnect the maintenance telephone from the MDF block.
- 4) Connect the TMS to the maintenance telephone port (Figure 2).



**Figure 207: Test setup for measuring ERL and SRL on DID trunk channels**

- 5) Ensure that the TMS is in terminated mode with 600-Ohm impedance.
- 6) Have the facility provider seize the DID trunk under test and then terminate it with silent termination.
- 7) Using the TMS, measure and note the value of the ERL and the SRL.
- 8) Repeat steps 1 through 7 for balance network configurations with the COFIDX set to 3, 4, and 5.
- 9) Configure the balance network in the trunk configuration that provided the best ERL and SRL values.

### 13.10.3.3 Balancing OPS Lines and Trunks

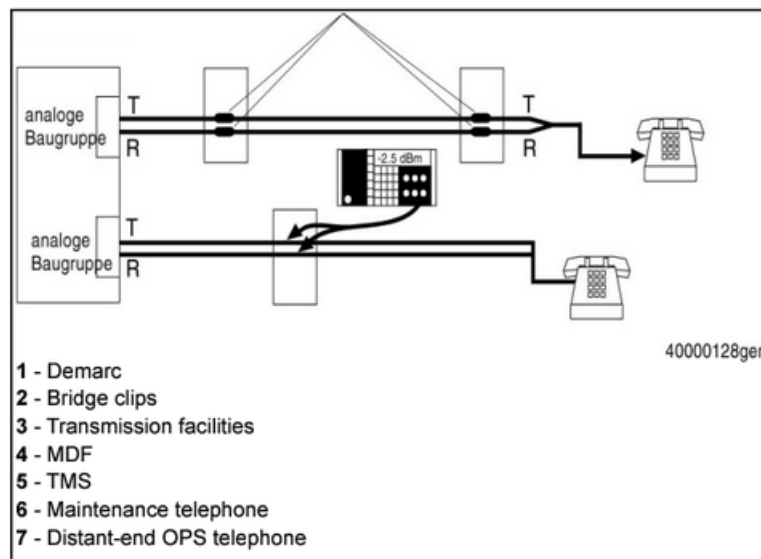
To determine the best OPS line configuration, perform the following:

## Verifying the System

- 1) Set the balance network in the trunk configuration to 1 as follows:
  - a) Type the command `CHA-SCSU` and press Enter.
  - b) Type the following field values and confirm every input with Enter:
 

Field	Value
STNO	<OPS extension #>
DEVFUNC	ANATE
COFIDX	5
- 2) Activate the OPS line to load the new balance network as follows:
  - a) Type the command `ACT-DSSU` and press Enter. Type the following field values and confirm every input with Enter:
 

Field	Value
ONTYPE	AUL
TYPE	STNO
STNO	<OPS extension #>
- 3) Disconnect the maintenance telephone from the MDF block.
- 4) Connect the TMS to the maintenance telephone port (Figure 3).



**Figure 208: Test setup for measuring ERL and SRL on OPS lines**

- 5) Verify that the TMS is in termination mode with 600-Ohm impedance.
- 6) Call the OPS telephone.
- 7) Have the distant-end take the OPS telephone off-hook.
- 8) Measure and note the ERL and SRL (low and high) values.
- 9) Repeat steps 1 through 8 for OPS line configurations for balance network configurations 2, 3, and 4.
- 10) Configure the balance network in the line configuration that provided the best ERL and SRL values.

## 13.10.4 Verifying ISDN Spans

Verify the functionality of the D channel of the ISDN span as follows:

- 1) Ensure that the local continuity and the end-to-end link tests have been performed.
- 2) Ensure that personnel on the far end of the ISDN span have been assigned to perform this verification procedure with you.
- 3) Activate the DIU2U board as follows:

- a) Type the command `ACT-BSSU` and press Enter.
- b) Type the following field values and confirm every input with Enter:

```
Field      Value
ONTYPE     AUL
LTG        <LTG>
LTU        <LTU>
SLOT       <SLOT>
```

- 4) Activate the D channel of the ISDN span as follows:

- a) Type the command `ACT-DSSU` and press Enter.
- b) Type the following field values and confirm every input with Enter:

```
Field      Value
ONTYPE     AUL
PEN        <PEN of the D channel>
```

- 5) Activate all the bearer channels of the ISDN span as follows:

- a) Type the command `ACT-DSSU` and press Enter.
- b) Type the following field values and confirm every input with Enter:

```
Field      Value
ONTYPE     AUL
PEN        <PEN1><PEN2>
```

The D channel becomes operational within 15 seconds.

If the D channel is not operational within 15 seconds after activation, check the configuration for the different types of applications in [Table 3](#) through [Table 6](#).

---

**IMPORTANT:** Record the device type and bipolar eight substitution information.

---

**Table 32: BCSU configuration checks for CorNet trunks**

BCSU Parameters	If the near end is	The far end should be
Timing type (TIMTYP)	SYST	LOOP
Frame (FRAME)	STD	STD
Bipolar eight substitution (BI8SUB)	YES	YES
Bipolar violation detection	YES	YES

BCSU Parameters	If the near end is	The far end should be
Network or user emulation (NETUSR)	NETWK	USER NETWK

**Table 33: TCSU configuration checks for CorNet trunks**

TCSU Parameters	If the near end is	The far end should be
Device type (DEV)	S1D	S1D
	S1B	S1B

**Table 34: BCSU configuration checks for AT&T, MCI, and SPRINT ISDN trunks**

BCSU Parameters	Near End
Timing type (TIMTYP)	LOOP
Frame (FRAME)	<STD or ESF> (Must be the same as the far-end configuration.)  If the frame = ESF, check the bipolar eight substitution (BI8SUB) value.
BI8SUB	<NO or YES> (Must be the same as the far-end configuration.)
Bipolar violation detection	<NO or YES> (Must be the same as the far-end configuration.)
Network or user emulation (NETUSR)	USER

**Table 35: TCSU configuration checks for AT&T, MCI, and SPRINT ISDN trunks**

TCSU Parameters	Far End
Protocol (PROTOCOL)	<ATT49, ATT59 or MCI for SPRINT and MCI2 for MCI> (Must be the same as the far-end configuration).

---

**IMPORTANT:** If all of the configurations are correct and the D channel is still not operational, contact your next level of support.

---

### 13.10.5 Verifying T1 Spans

To verify T1 spans:

1) Activate the DIU2U board as follows:

- a) Type the command `ACT-BSSU` and press Enter.
- b) Type the following field values and confirm every input with Enter:

Field	Value
ONTYPE	AUL
TYPE	PEN
PEN1	<PEN1>
PEN2	<PEN2>

2) Activate all the channels of the span as follows:

- a) Type the command `ACT-DSSU` and press Enter.
- b) Type the following field values and confirm every input with Enter:

Field	Value
ONTYPE	AUL
TYPE	<PEN>
PEN1	<PEN1>
PEN	<PEN2>

- 3) Ensure that the local continuity and the end-to-end link tests have been performed.
- 4) Perform a bit error rate test (BERT). Should the BERT fail, contact your local provider.
- 5) Display the current link error count of the T1 span as follows: Type the command `DIS-BSSU` and press Enter. Repeat this action several times.

Field	Value
LTG	1
LTU	<LTU>
SLOT	<SLOT>
CCTNO	<blank>
DIS-TYPE	<blank>
RESET	<blank>

After 15 seconds, the T1 span enters the green alarm state and the following errors stop increasing:

- Bipolar error seconds (BES)
- Out-of-frame error seconds (OES)
- Up slips (US)
- Down slips (DS)
- Error seconds (ES)
- Frame slips (FS)

If the T1 span enters the green alarm state but the errors are increasing, perform a BERT.

### 13.10.6 Recording Circuit IDs

Record circuit IDs in the Jack and Pin Record Data Sheet of the 9751 CBX and 9200 CBX System Site Log.

### 13.11 Verifying the Hard Disk

Verify the hard disk as follows:

- 1) Check the status of the hard disk drive as follows:

- a) Type DIS-DSKST and press Enter.
- b) Enter the following values and press Enter after each:

Field	Value
UNIT	<A1, V1, T1>
TYPE	C
CNO	<1 - 8>

The screen displays IN SERVICE.

- 2) If the drive is not ready, repeat steps 1a and 1b, and proceed to the following steps:

- a) Enter the command ACT-DSKX and press Enter.
- b) Enter the following values and press Enter after each:

Field	Value
UNIT	<A1, V1, T1>
CNO	<1 - 8>

### 13.12 Verifying the Operation of System Features and Servers

This section provides test procedures to verify the availability of the OpenScope 4000 system features as well as the server functionality.

#### 13.12.1 Testing CDR

Test the call detail recording (CDR) list output of the system as follows:

- 1) Print the following information by typing the commands shown in [Table](#) , one at a time.

**Table 36: CDR reports to retrieve**

Command	Information to Retrieve
DIS-MSEL	Operating condition, basic device (BASDEB), STNTBL1, and DNOTBL1
DIS-MLIST	Station number
DIS-MFREQ	DIALOGFIELD

- 2) From the DIS-MSEL printout, select a selection group that has OPERATION CONDITION = ON.
- 3) If STNTBL1=N, and DNOTBL1=N, then all stations are valid for CDR. If STNTBL1=Y, and DNOTBL1=Y, find valid stations for CDR from the command DIS-MLIST printout.
- 4) If BASDEV=DEV#, then the CDR must be sent to a printer or a terminal (depending on the configured device on port 1 of the ADP).
- 5) Make an external call from any valid station. The CDR must be sent either to a printer or to a terminal when the call is completed.
- 6) If BASDEV=CDRC1 or (CDRC2), then the CDR must be sent to a file. From the FCP DISMFREQ printout, if at least one dialog field number exists, establish an external call from any valid station.
- 7) Type the command DIS-MFREQ and then press Enter.
- 8) Type the field value DIAFNO=<dialog field #>, and then press Enter.
- 9) The CDR must be sent to a file.
- 10) If the dialog fields are free in the DIS-MFREQ command printout: type the command ADD-MFREQ and press Enter.
- 11) Type the following field values and confirm every input with Enter:
 

Field	Value
TYPE	L
DIAFNO	1
FILE	CDRC1
FILESTA	<YYMMDDHHmm>
FILEEND	<YYMMDDHHmm>
FORMFORM0	2
BLKSIZE	127
FOUT	Y
STAT	YYMMDDHHmm>
MULTOUT	N
PERIOD	0
SELSTOP	Y
- 12) Make an external call from any valid station.
- 13) Type the command OUT-MFREQ and press Enter.
- 14) Type the field value DIAFNO=<1> and then press Enter.
- 15) When the CDR test is finished, type the command DEL-MFREQ and press Enter.
- 16) Type the field value DIAFNO=<|> and then press Enter.

### 13.12.2 Testing Least-Cost Routing

Test the least-cost routing (LCR) configuration of the system after all of the outgoing trunks have been cut over and tested as follows:

- 1) Print the reports in [Table](#).

**Table 37: LCR reports to retrieve**

Command	Parameters to Set	Information to Retrieve
DIS-LROUT		Trunk group numbers and route numbers
DIS-LDPLN		Dialing patterns and route numbers
DIS-LSCHD		LCR schedule
DIS-LAORT		Area code and office code restrictions
DIS-LCOS		LCR classes of service
DIS-DPLN	TYPE=STN	ROLMnet dialing patterns and route numbers
DIS-TGACC		PEN locations of trunk circuits

- 2) Select a dialing pattern from the Dialing Patterns and Route Numbers report.
- 3) Note the route number that is associated with the selected dialing pattern.
- 4) Note the first trunk group (route element) associated with the route number in the Trunk Group Numbers and Route Numbers report.
- 5) Ensure that the trunk group is available to test as follows:
  - a) Check the LCR schedule report to ensure that the LCR schedule presently allows access to the selected route element. (Look at the Trunk Group Numbers and Route Numbers report and note the letters under the SCHEDULES field that have been marked with an X. Use these letters as an input to the LCR schedule report.) If the schedule blocks a call to that trunk group, change the system date and time to comply with the schedule, by typing the command `CHADATE`.
  - b) Check for a READY status of the actual trunk circuits in that group by typing the command `DIS-SDSU-TK` with the PENs found in the PEN locations of the trunk circuits report.
  - c) Check the AUTH field of the Trunk Group Numbers and Route Numbers report to ensure that the LCOS for the maintenance extension is high enough to use that route by typing the command `DIS-SCSU` to find the LCOSV of the maintenance extension.
  - d) Check the AORT field of the Trunk Group Numbers and Route Numbers report to ensure that the test number does not contain an area code or office code that is blocked for that route. Use the AORT index number from the Trunk Group Numbers and Route Numbers report in the DIS-LAORT report to check this.
- 6) Dial a far-end test number that incorporates the selected dialing pattern. Ensure that the call is complete.
- 7) Ensure that one of the trunks in the trunk group was seized by call processing, by typing the command `DIS-SDSU` with the PENs found in the PEN Locations of Trunk Circuits report. The initials CP should appear in the status field.
- 8) Deactivate the trunk group by typing the command `DEADSSU` with the PENs found in the PEN Locations of Trunk Circuits report.

- 9) Repeat steps 4 through 8 with the remaining route elements (trunk group) in the route.
- 10) Repeat steps 3 through 9 with the remaining dialing patterns in the Dialing Patterns and Route Numbers report.
- 11) Repeat steps 2 through 9 with a ROLMnet extension from each route found in the ROLMnet Dialing Patterns and Route Numbers report.
- 12) If the date and time were changed in step 5a, reset them to their correct values.

### **13.13 Verifying the System Bypass**

Verify the system bypass as follows:

- 1) Check the punch down sequence of the DSCXL2 board.
- 2) Refer to the OpenScape 4000 Service Manual for the OLED information on the DSCXL2 board to check whether the system bypass is functioning properly.

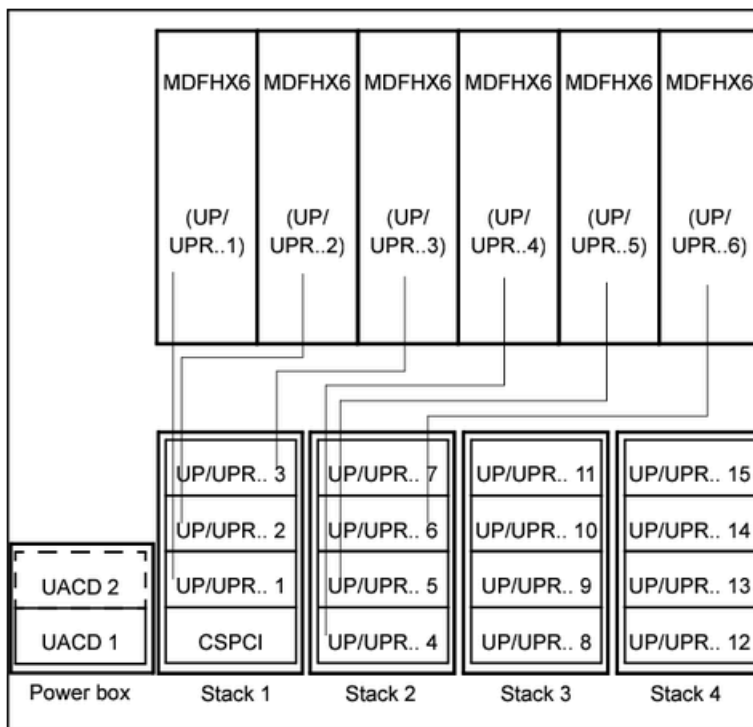
### **13.14 Customer Training, I.M.**

Once the system is fully operational, basic training is to be provided for each system. The customer is responsible for nominating the participants in the basic training.

## 14 Adding Cabinets to the System

This section describes procedures to add cabinets to the OpenScope 4000.

### 14.1 Expansion Configuration



**Figure 209: Expanded OpenScope 4000 configuration with maximum MDFHX6 number**

The expansion cabinets in a multiple-cabinet system (maximum four cabinets) are on top of the basic (CC80F) cabinet. The expansion cabinets are secured together using quick-release locks on the front.

To expand the system:

---

**NOTICE:** The connecting screws between the individual cabinets are not used for internal grounding purposes.

---

- 1) Release the cabinet by turning the quick-release locks 90° to the left or right (see [Figure 4](#)).
- 2) Lift the housing cover off the base cabinet.

---

**IMPORTANT:** The housing cover and backplane are also secured in the same manner as the expansion cabinets. This allows components to be removed individually after the quick-release locks have been released.

---

- 3) Mount the expansion cabinet on top of the existing expansion cabinet.
- 4) Secure with screws.

- 5) Refer to the hardware to connect the telephony cables.



**Figure 210: Removing system components**

## 14.2 Connecting the Cabinet Stacks

To connect the cabinet stacks, refer to [Section 6.2.2, Installing the Ground Straps Between Cabinets](#)

# Index

## B

- Balance network
  - overview [263](#)
  - selecting [264](#)
- Balancing CO trunks [265](#)
- Balancing DID trunks [266](#)
- Balancing OPS lines and trunks [267](#)
- Battery
  - connecting to the power box [125](#)
- Battery cable cross-sections [206](#)

## C

- Cable routing
  - AP 3700-13 to MDF (MDFHX6) [218](#)
  - LTU-MDF (MDFHX6) [217](#)
- Cabling assemblies
  - external [216](#)
- CO trunks
  - balancing [265](#)
- Connecting the power box to the system [204](#)

## D

- DID trunks
  - balancing [266](#)
- Distance adapter
  - installing [247](#)

## G

- Grounding
  - AP 3700 cabinets [95](#), [95](#)
- Grounding overview 2 [100](#)

## H

- Hard disk
  - checking [272](#)

## I

- Installation notes [43](#)
- Installation variants [65](#)
- Installation with AP 3300 cabinets [65](#)
- ISDN spans
  - verifying [268](#)

## L

- LPC80 setting options [115](#)

## M

- Mains connection
  - overview of mains connection 1 [108](#)
  - single-phase network [107](#)
  - three-phase network [106](#)
  - variants [102](#)
  - with mid-point grounding [108](#)
- MCM
  - ALUM cable types [221](#)
- MDF power supply [126](#)
- MDFHX6
  - assembly [216](#)

## O

- OPS lines and trunks
  - balancing [267](#)
- Overvoltage protection for boards [219](#)

## S

- Shelf Configuration [71](#)
- Site verification [37](#)
- Strapping lists [236](#)
- System bypass
  - verifying [275](#)

## T

- Testing
  - CDR [272](#)
  - LCR [273](#)
- Trunk bypass
  - installing [215](#)

## U

- UACD power box [196](#)

## V

- Verifying
  - ISDN spans [268](#)
  - system bypass [275](#)
- Verifying the hard disk [272](#)
- Verifying the system
  - tools required [261](#)

