



A MITEL
PRODUCT
GUIDE

Unify OpenScape Alarm Response Economy

OScAR-Eco 200 V5

Servicehandbuch

07/2024

Notices

The information contained in this document is believed to be accurate in all respects but is not warranted by Mitel Europe Limited. The information is subject to change without notice and should not be construed in any way as a commitment by Mitel or any of its affiliates or subsidiaries. Mitel and its affiliates and subsidiaries assume no responsibility for any errors or omissions in this document. Revisions of this document or new editions of it may be issued to incorporate such changes. No part of this document can be reproduced or transmitted in any form or by any means - electronic or mechanical - for any purpose without written permission from Mitel Networks Corporation.

Trademarks

The trademarks, service marks, logos, and graphics (collectively "Trademarks") appearing on Mitel's Internet sites or in its publications are registered and unregistered trademarks of Mitel Networks Corporation (MNC) or its subsidiaries (collectively "Mitel), Unify Software and Solutions GmbH & Co. KG or its affiliates (collectively "Unify") or others. Use of the Trademarks is prohibited without the express consent from Mitel and/or Unify. Please contact our legal department at iplegal@mitel.com for additional information. For a list of the worldwide Mitel and Unify registered trademarks, please refer to the website: <http://www.mitel.com/trademarks>.

© Copyright 2024, Mitel Networks Corporation

All rights reserved

Table of Content

1	Conventions and Operating Instructions	1-1
1.1	Overview of the chapters in this document	1-2
1.2	Notations and symbols	1-3
1.3	Reporting of accidents	1-3
1.4	Data protection and data security	1-4
2	OScAR 200 Specification	2-5
2.1	General	2-5
2.2	PBX connectivity	2-5
2.3	Overview of OScAR 200 and peripheral components	2-6
2.4	Certifications	2-6
2.5	Characteristics of OScAR 200	2-7
2.6	Icons and lettering	2-7
3	Product Components	3-1
3.1	OScAR 200 components	3-3
3.1.1	Face views	3-3
3.1.1.1	Face view without ISDN	3-3
3.1.1.2	Face view S0	3-3
3.1.1.3	Face view E1/T1	3-3
3.1.2	Rear view	3-3
3.2	Rear connections	3-4
3.2.1	Power supply AC	3-4
3.2.2	Power supply DC	3-4
3.2.3	CompactFlash card insertion	3-5
3.2.4	Relay contacts	3-6
3.2.5	Connection of the DCF receiver	3-7
3.3	Front connections	3-8
3.3.1	Reset button	3-8
3.3.2	Status indicator	3-8
3.3.3	Ethernet interfaces	3-9
3.3.4	COM interfaces	3-10
3.3.5	S0 interfaces	3-11
3.3.6	E1/T1 interfaces	3-12
3.3.7	USB-Service interface	3-13
3.3.8	USB device interfaces	3-14
3.4	Last fault signaller MARS (= Major-Alarm-Remote-Signaller)	3-15
3.4.1	Functionality	3-15
3.4.2	Product Component MARS adapter	3-15
3.5	Add ons	3-16
3.5.1	DC power supply unit	3-16
3.5.2	Digital I/O	3-17
3.5.2.1	Gateway	3-17
3.5.2.2	I/O Module Standard	3-18
3.5.2.3	I/O Module Secure	3-20
3.5.3	DCF-77 radio receiver	3-23
3.5.4	USB/RS232 interface	3-24

Table of Content

3.5.5	CompactFlash card	3-24
3.5.6	Printer	3-25
3.6	Line extensions	3-27
3.6.1	CSA converter	3-27
3.6.2	SMS radio modem	3-27
3.6.3	Transmission kit for OScAR 200 to printer	3-28
3.6.4	Transmission kit for printer	3-29
3.7	General adapters	3-30
3.7.1	DCE adapter	3-30
3.7.2	DTE adapter	3-31
3.7.3	PRN adapter	3-32
3.7.4	PRT adapter	3-33
3.7.5	Twin outlet line jack unit S0 (shielded)	3-34
3.7.6	Single outlet line jack unit RS422 (unshielded)	3-35
3.7.7	Patch field	3-35
3.8	General cable cords	3-36
3.8.1	DC power supply cable	3-36
3.8.2	AC connector cable Germany	3-37
3.8.3	AC connector cable USA	3-37
3.8.4	USB cable cord	3-37
3.8.5	Patch cable cord	3-38
3.8.6	RS232 data cable cord	3-39
4	Hardware Operations	4-41
4.1	General safety instructions	4-41
4.2	Safety instructions OScAR	4-43
4.3	Safety instructions for Denmark	4-43
4.4	Safety instructions for Norway	4-43
4.5	Safety instructions for Finland	4-43
4.6	Safety instructions for Sweden	4-43
4.7	Installation and replacement of ISDN modules in OScAR 200	4-44
5	Wiring Plans	5-53
5.1	Power supply	5-54
5.2	USB service	5-56
5.3	Ethernet interface	5-57
5.4	USB port	5-58
5.5	ISDN E1/T1 interface	5-59
5.6	ISDN S0 interface	5-61
5.7	COM interface	5-63
5.8	Line extension of the COM interface	5-65
5.9	Line extension of the protocol printer for logging (Leiser)	5-67
5.10	Line extension of the host interface (without handshake)	5-68
5.11	Schauf Hallway Displays	5-69
6	PBX Systems and Soft Switches	6-71

1 Conventions and Operating Instructions



Note:

This document is written for service engineers and technicians who carry out the initial installation and start up of OScAR 200.

Overview

This chapter covers the notations and the symbols that are used throughout this document. It also offers valuable instructions and provides information on data protection and data security.

Content

The following areas are covered in this chapter:

- 1.1 Overview of the chapters in this document
- 1.2 Notations and symbols
- 1.3 Reporting of accidents
- 1.4 Data protection and data security

Information on the product designation

- OScAR Eco 200 is the name of the hardware platform
- The overall product designation can be OScAR Eco 200 or OScAR Pro 200.
- The product designation when marketed and sold through Unify reads: OScAR Eco 200 or OScAR Pro 200 (OScAR = Open Scape Alarm Response).
- The screenshots in this document carry the product-independent hardware designation OScAR Eco 200 or OScAR Pro 200.

1.1 Overview of the chapters in this document

This document also includes the following chapters:

Chapter	Description
Chapter 2, " OScAR 200 Specification"	This chapter gives you an overview of the hardware configuration of OScAR 200.
Chapter 3, "Product Components"	This chapter gives you an overview of the basic technical characteristics of OScAR 200.
Chapter 4, "Hardware Operations"	This chapter describes the hardware operations on the server and also includes the safety instructions in German, Finnish, Danish and Swedish.
Chapter 5, "Wiring Plans"	This chapter covers the different wiring plans of OScAR 200.
Chapter 6, "PBX Systems and Soft Switches"	This chapter covers in brief the coupling of OScAR 200. to the PBX network or the convergent voice/ data networks and to the trunk connections. It also refers to the external configuration instructions for the respective interface(s).

Table 1-1 Overview of chapters

1.2 Notations and symbols

Notations

The following definitions are used in this document:

Text	All texts from files that are described in this document, and all entries that are added to these files, appear in the monospace font <i>Courier</i> .
The password 123456 ...	Details and instructions in the continuous text that are of particular importance or must be heeded are output in bold print. In the same way, buttons and menus also appear in bold print.
The file <code>global.cfg</code>	Files and directories are output in the monospace font <i>Courier</i> .
<Placeholder>	Entries and outputs, both of which may vary dependent on the individual situation in which they appear, are placed in angle brackets and are in italics.
[beginning of value range ... end of value range; default] or [X]	All default values and all value range details from data fields are placed in squared brackets and appear in italics. The suffix [x] after a possible entry in a database field indicates that this option is also the default value.

Table 1-2 Notations

Symbols

The following symbols are used in this document:



Note:

The info "i" is used to indicate additional helpful information.



Caution!

The exclamation mark is used to indicate important information which the reader should treat with particular caution.



Warning!

The warning sign is used to alert you to a hazardous or high risk situation. It means that you are currently exposed to a risk or hazardous situation that may cause physical injury. Before you start working with any apparatus, please always be aware of the risks that may arise in connection with the device's electric currents and follow the standard practices to avoid accidents.

1.3 Reporting of accidents

- Be careful to report all accidents immediately, also near accidents and any potential safety hazard.
- Report every electrical shock, no matter how small.
- Never allow the storage of easily inflammable substances in the proximity or even in the same room with the communications system.
- Make sure the work area is always well lit.
- Remember that an untidy work area can lead to accidents.

1.4 Data protection and data security

In order to comply with the legal provisions that apply when providing services, from any service performed at customers' sites to teleservice, we strongly urge all readers to follow the below-listed best practices. This will not only help you protect the interests and concerns of customers and clients, but also avoid unwanted implications for yourself.

Please help ensure complete data protection and data security by being aware of these issues as you work:

- Always make sure that only authorized persons have access to your client and customer data.
- Assign passwords whenever you can. Do not grant unauthorized persons access to your passwords, for example by writing them down.
- Always make sure that no unauthorized persons can process (e. g. save, edit, transmit, block, or delete) or utilize customer data in any way.
- Always make sure that no unauthorized persons have access to data storage media, for example to backup disks or printouts of logfiles or reports This applies both to service work provided directly at the customer and to the storage and transport of data carriers.
- Always make sure that every data storage medium that is no longer needed is properly and fully destroyed. Also be careful not to leave behind any papers that could become openly accessible to others.



Note:

We urge all readers to work together closely with the contact persons of your clients. This not only helps to build trust but will also help you reduce your own workload.

2 OScAR 200 Specification

Overview

This chapter gives you an overview of the hardware configuration of OScAR 200.

Content

The following areas are covered in this chapter:

- 2.1 General
- 2.2 PBX connectivity
- 2.3 Overview of OScAR 200 and peripheral components
- 2.4 Certifications
- 2.5 Characteristics of OScAR 200
- 2.6 Icons and lettering

2.1 General

- The telecommunications server OScAR 200 is part of the OScAR family.
- OScAR 200 is designed for up to 60 channels and bridges the gap between OScAR 300 with a capacity of up to 480 channels, and OScAR100 with a system size of 8 channels.
- OScAR 200 comes as a 19" installation device with 1 height unit, and is designed for the installation in a rack.
- The system comes with:
 - two processor systems on Power-PC basis and digital signal processor
 - LINUX © operating system
 - Power Supply AC or DC, also at the same time (emergency power supply), low power consumption
 - 2x Ethernet interfaces (10/100 Mbit/s) for connectivity to the LAN
 - 2x serial asynchronous interfaces RS232, RS422 (COM port, electrically isolated also among each other) for host coupling(s), e.g. host couplings to call systems
 - 2x USB host interfaces to connect to a protocol printer or radio modem, and/or for connectivity of remote digital I/Os
 - 1x USB device interface for link-up of a terminal emulation program (start-up functions)
 - 1x connection option for remote DCF-77 receiver
 - 1x relay output for process messages, with make and break contact
 - Pluggable CompactFlash card
 - Optional pluggable ISDN/TDM modules in the following versions:
 - S₀ module with 4 ports (up to 8 channels)
 - E1(S_{2M})/T1 module with 2 ports (dependent on the system site 1 or 2 ports can be used for up to 30/60 channels)

2.2 PBX connectivity

OScAR 200 applies voice codec G.711 A-Law or μ -Law and is connected to a PBX or softswitch with up to 30 channels, either:

- via ISDN with up to 4x ISDN-S₀ digital trunks or via 1x E1(S_{2M})/T1 digital trunk, or
- with VoIP trunking via LAN interface (10/100BASE-T).

2.3 Overview of OScAR 200 and peripheral components

The below picture illustrates OScAR 200 with its periphery components:

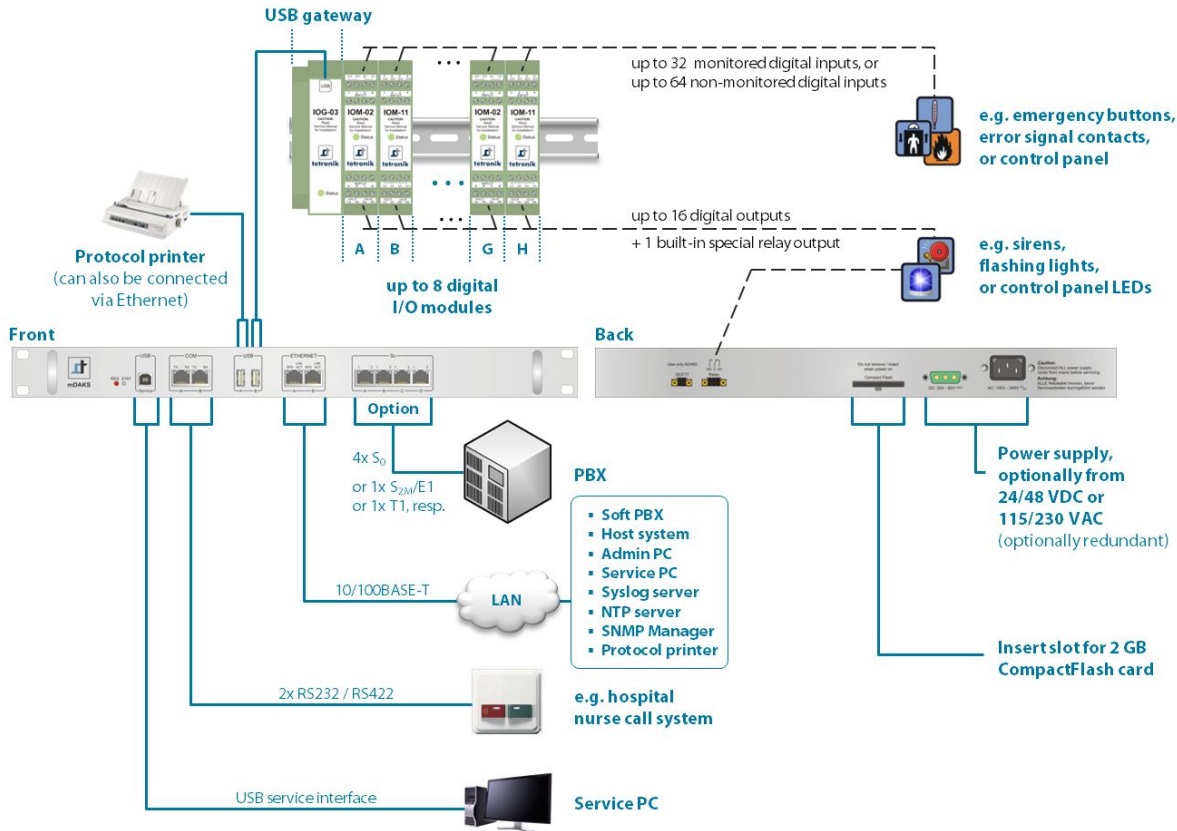


Image 2-1 Overview of OScAR 200 and peripheral components

2.4 Certifications

This device is certified in these countries in keeping with UL, FCC, CE and Australia RCM (country codes as in ISO 3166):

- All EU countries:
AT, BE, BG, CY, CZ, DE, DK, EE, ES, FI, FR, GB, GR, HR, HU, IE, IT, LT, LU, LV, MT, NL, PL, PT, RO, SE, SI, SK
- These countries outside the EU:
AU, CA, CH, CO, HK, ID, ME, MK, MY, NZ, PA, PH, RS, SG*, TR, US

* Singapore: Available as industrial product only

Fire security and life safety features were not evaluated during the UL test.

Status: June 06th, 2019 – National approvals subject to change.

2.5 Characteristics of OScAR 200

The below table lists the characteristics of OScAR 200:

Description	Value
Dimensions	<ul style="list-style-type: none"> height 41 mm width 483 mm depth 215 mm
Weight	<ul style="list-style-type: none"> max. configuration 2800 g
Power supply	AC power supply <ul style="list-style-type: none"> Voltage range 100 V - 240 V 50/60 Hz Current consumption 0.25 A - 0.13 A DC power supply <ul style="list-style-type: none"> Voltage range 20 V - 60 V Current consumption 0.9 A - 0.3 A
Ventilation	Convective air cooling
Operating conditions	<ul style="list-style-type: none"> Temperature: +5 °C .. +35 °C Relative Humidity: 5 % .. 80 % (non-condensing)
Storage conditions and terms of transport	<ul style="list-style-type: none"> Temperature: -20 °C .. +70 °C Relative Humidity: 5 % .. 80 % (non-condensing)
MTBF	> 400,000 h (over a 5-year period under report)
Certifications/ Declarations of conformity and compliance	<ul style="list-style-type: none"> EN 55024 EN 55032 EN 60950-1 UL 60950-1 FCC 47 CFR Part 15 CE Marking CB Scheme RCM Marking

Table 2-1 OScAR 200 characteristics

2.6 Icons and lettering

The following icons and lettering can be found on OScAR 200, cables etc.:



Icons / Lettering	Description
	Name and contact details of the manufacturer
	Month and year of the product's productions

Table 2-2 OScAR 200 icons and lettering

Icons and lettering










Icons / Lettering	Description
	<p>Obligatory inspection of the accompanying documents (ISO7010-M002)</p>
	<p>Connection to the supply network: Alternating Current, A.C. (IEC60417-5032) AC: Rated voltage, e.g. 100V-240V Rated supply frequency: z.B. 50/60Hz Rated electrical power consumption in ampere: e.g. 0.25A-0.13A</p>
	<p>Connection to the supply network: Direct Current, D.C. (IEC60417-5031) DC: Rated voltage, e.g. 20V-60V Rated electrical power consumption in ampere: e.g. 0.9A-0.3A</p>
	<p>Meaning of this icon: See "OScAR User Manual"</p>
	<p>CE marking means a marking by which the manufacturer indicates that pursuant to the Regulation (EC) No 765/2008 "...the product is in compliance with the applicable requirements set out in Community harmonization legislation providing for its affixing". (Includes RoHS 2 Conformity)</p>
	<p>UKCA Marking Hereby, Unify Software and Solutions GmbH & Co. KG declares that the OpenScope Alarm Response is in compliance with EU Directives 2014/30/EU, 2014/35/EU and 2011/65/EU as well as the UK Electrical Equipment (Safety) Regulations 2016, UK Electromagnetic Compatibility Regulations 2016 and UK RoHS Regulations 2012.</p>
	<p>The UL-listed recognized component mark by Underwriters Laboratories is proof that this product has been evaluated by UL to the applicable US and Canadian standards and found suitable for use in Canada and the USA.</p>
	<p>The FCC test mark is proof that the Federal Communications Commission has tested and evaluated this product with its own and other standards.</p>
	<p>The RCM sign (Regulatory Compliance Mark) is proof that the product is in compliance with regulatory measures (ACMA, RSM and Australian Communications). It constitutes the registration mark for both the Australian and the New Zealand market.</p>

Table 2-2 OScAR 200 icons and lettering

Icons and lettering

Icons / Lettering	Description
OscAR Vxx.yy	Name of the software incl. the number of the version and revision: <ul style="list-style-type: none">• at the server• in the user software

Table 2-2 OscAR 200 icons and lettering

3 Product Components

Overview

This chapter gives you an overview of the basic technical characteristics of OScAR 200.



Warning!

All external components that are connected to A31003S1850S101017620 must meet and comply with the pertinent legal provisions that are currently in force in the country in which they are operated.

Content

- 3.1 OScAR 200 components
 - 3.1.1 Face views
 - 3.1.1.1 Face view without ISDN
 - 3.1.1.2 Face view S0
 - 3.1.1.3 Face view E1/T1
 - 3.1.2 Rear view
- 3.2 Rear connections
 - 3.2.1 Power supply AC
 - 3.2.2 Power supply DC
 - 3.2.3 CompactFlash card insertion
 - 3.2.4 Relay contacts
 - 3.2.5 Connection of the DCF receiver
- 3.3 Front connections
 - 3.3.1 Reset button
 - 3.3.2 Status indicator
 - 3.3.3 Ethernet interfaces
 - 3.3.4 COM interfaces
 - 3.3.5 S0 interfaces
 - 3.3.6 E1/T1 interfaces
 - 3.3.7 USB-Service interface
 - 3.3.8 USB device interfaces
- 3.4 Last fault signaller MARS (= Major-Alarm-Remote-Signaller)
 - 3.5.1 DC power supply unit
 - 3.5.2 Digital I/O
 - 3.5.2.1 Gateway
 - 3.5.2.2 I/O Module Standard
 - 3.5.2.3 I/O Module Secure
 - 3.5.3 DCF-77 radio receiver
 - 3.5.4 USB/RS232 interface
 - 3.5.5 CompactFlash card
 - 3.5.6 Printer
- 3.6 Line extensions
 - 3.6.1 CSA converter
 - 3.6.2 SMS radio modem
 - 3.6.3 Transmission kit for OScAR 200 to printer
 - 3.6.4 Transmission kit for printer
- 3.7 General adapters
 - 3.7.1 DCE adapter
 - 3.7.2 DTE adapter
 - 3.7.3 PRN adapter
 - 3.7.4 PRT adapter
 - 3.7.5 Twin outlet line jack unit S0 (shielded)
 - 3.7.6 Single outlet line jack unit RS422 (unshielded)

- 3.7.7 Patch field
- 3.8 General cable cords
 - 3.8.1 DC power supply cable
 - 3.8.2 AC connector cable Germany
 - 3.8.3 AC connector cable USA
 - 3.8.4 USB cable cord
 - 3.8.5 Patch cable cord
 - 3.8.6 RS232 data cable cord

3.1 OScAR 200 components

3.1.1 Face views

3.1.1.1 Face view without ISDN

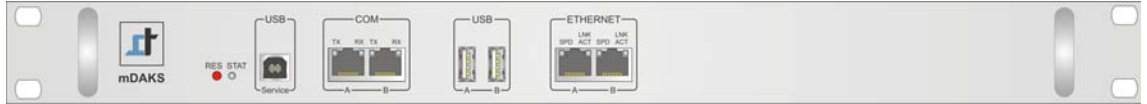


Image 3-1 Face view without ISDN

3.1.1.2 Face view S₀

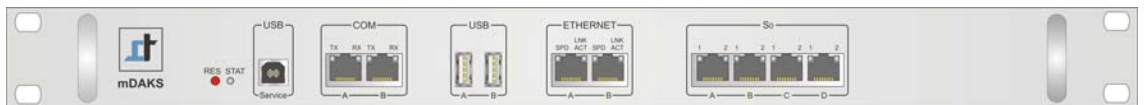


Image 3-2 Face view S₀

3.1.1.3 Face view E1/T1



Image 3-3 Face view E1/T1

3.1.2 Rear view



Image 3-4 Rear view

3.2 Rear connections

3.2.1 Power supply AC



Image 3-5 Power supply AC

Element	Description
AC	IEC jack for an IEC inlet connector for non-heating apparatus to connect OScAR 200 to the mains power supply Technical details: <ul style="list-style-type: none"> • Input voltage 100 ... 240 V AC; 50/60 Hz • Power consumption approx. 25 W

Table 3-1 Power supply AC

3.2.2 Power supply DC



Image 3-6 Power supply DC

Element	Description
DC	Pin assignment: <div style="text-align: center;"> </div> <ul style="list-style-type: none"> A1: - DC A2: GND A3: + DC Technical details: <ul style="list-style-type: none"> • Voltage range 20 .. 60 V DC • Power consumption approx. 20 W

Table 3-2 Power supply DC

3.2.3 CompactFlash card insertion

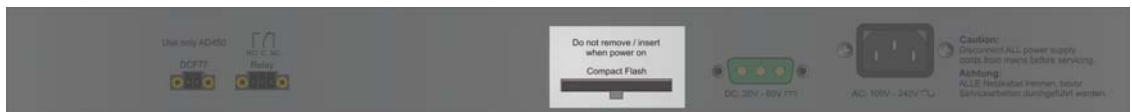


Image 3-7 CompactFlash Card - Insert

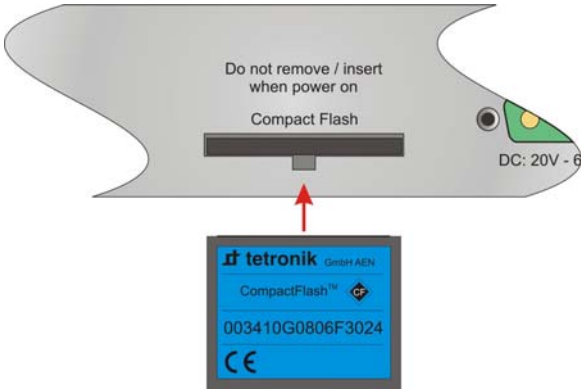
Element	Description
CompactFlash card	Utilization: 

Table 3-3 CompactFlash card usage



Caution!
Be careful to cut the power supply (AC and DC) of OScAR 200 before you insert or remove the CompactFlash card.



Caution!
Make sure you only use the CompactFlash card TNK:MD-CF2-4G.
This card may NOT be replaced with any other commercially available CompactFlash card.
➤ see Section 3.4 "Last fault signaller MARS (= Major-Alarm-Remote-Signaller)"

3.2.4 Relay contacts



Image 3-8 Relay contacts


Element	Description
Relay	<p>Pin assignment:</p> <div style="text-align: center;">  </div> <p>Pin 1: NO Pin 2: COM Pin 3: NC</p> <p>Technical details:</p> <ul style="list-style-type: none"> • U_{max} 60 V AC • I_{max} 1 A • P_{max} 30 W

Table 3-4 Relay contacts

3.2.5 Connection of the DCF receiver



Image 3-9 Connection of the DCF receiver


Element	Description
DCF 77	Pin assignment:  Pin 1: DCF receiver + Pin 2: DCF receiver -

Table 3-5 Connection of the DCF receiver



Caution!
 Only connect the DCF receiver of the type TNK:AD450 or AD650.
 See Section 3.5.3 "DCF-77 radio receiver".



Caution!
 Wrong wiring can lead to irreversible damage or destruction of OScAR 200.

3.3 Front connections

3.3.1 Reset button



Image 3-10 Reset button

Element	Description
RES	Reset button to reset OScAR 200

Table 3-6 Reset button

3.3.2 Status indicator



Image 3-11 Status indicator

Element	Description
STAT	Status indication using 3-color light-emitting diode (LED): <ul style="list-style-type: none"> • OFF Mains failure, electrical fuse activated • red Reset • red blinking Internal error • Yellow Currently booting • yellow blinking Basic system is ready for operation, operating system is running, connection via VCON is possible (*see 'User Manual'), application or other software components not active • green-red blinking OScAR 200 is not enabled • green-yellow blinking Application has started, working data is missing • green Ready to operate • Green blinking Ready-to-operate, OScAR 200 is active

Table 3-7 Status indicator

3.3.3 Ethernet interfaces



Image 3-12 Ethernet interfaces

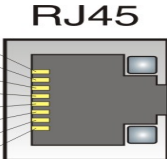
Element	Description
ETH A ETH B	<p>RJ45 socket for connectivity to the LAN (10-,100-Base-T)</p> <p>Pin assignment:</p> <div style="display: flex; align-items: center;"> <div style="margin-right: 10px;"> <p>8</p> <p>7</p> <p>6</p> <p>5</p> <p>4</p> <p>3</p> <p>2</p> <p>1</p> </div>  <div style="margin-left: 10px;"> <p>RJ45</p> <p>Pin 1: Tx+</p> <p>Pin 2: Tx-</p> <p>Pin 3: Rx+</p> <p>Pin 4: n.c.</p> <p>Pin 5: n.c.</p> <p>Pin 6: Rx-</p> <p>Pin 7: n.c.</p> <p>Pin 8: n.c.</p> </div> </div>
LED SPD	<p>Data rate of the Ethernet interface:</p> <ul style="list-style-type: none"> • OFF: Link 10 Mbit/s • green: Link 100 Mbit/s
LED LNK ACT	<p>Link and activity of the Ethernet interface:</p> <ul style="list-style-type: none"> • OFF: No link • green: Link • green blinking: Traffic

Table 3-8 Ethernet interface

3.3.4 COM interfaces



Image 3-13 COM interfaces

Element	Description																											
COM A COM B	<p>RJ45 jack for connectivity to external serial expansions (electrically isolated):</p> <ul style="list-style-type: none"> • RS232 • RS422 • RS485 <p>Pin assignment:</p> <table border="0"> <tr> <td></td> <td>RS232</td> <td>RS422</td> </tr> <tr> <td>Pin 1:</td> <td>n. c.</td> <td>n. c.</td> </tr> <tr> <td>Pin 2:</td> <td>RTS</td> <td>Tx+/Y</td> </tr> <tr> <td>Pin 3:</td> <td>GND</td> <td>GND</td> </tr> <tr> <td>Pin 4:</td> <td>TxD</td> <td>Tx-/Z</td> </tr> <tr> <td>Pin 5:</td> <td>RxD</td> <td>Rx+/A</td> </tr> <tr> <td>Pin 6:</td> <td>n. c.</td> <td>n. c.</td> </tr> <tr> <td>Pin 7:</td> <td>CTS</td> <td>Rx-/B</td> </tr> <tr> <td>Pin 8:</td> <td>DTR</td> <td>n. c.</td> </tr> </table>		RS232	RS422	Pin 1:	n. c.	n. c.	Pin 2:	RTS	Tx+/Y	Pin 3:	GND	GND	Pin 4:	TxD	Tx-/Z	Pin 5:	RxD	Rx+/A	Pin 6:	n. c.	n. c.	Pin 7:	CTS	Rx-/B	Pin 8:	DTR	n. c.
	RS232	RS422																										
Pin 1:	n. c.	n. c.																										
Pin 2:	RTS	Tx+/Y																										
Pin 3:	GND	GND																										
Pin 4:	TxD	Tx-/Z																										
Pin 5:	RxD	Rx+/A																										
Pin 6:	n. c.	n. c.																										
Pin 7:	CTS	Rx-/B																										
Pin 8:	DTR	n. c.																										
LED TX	<p>Status indicator:</p> <ul style="list-style-type: none"> • Universal LED • Standard function: TxD (green for data transfer) • Function depends on protocol or application, possible colors are: red, yellow, green • Tx blinks green when outbound data traffic is active 																											
LED RX	<p>Status indicator:</p> <ul style="list-style-type: none"> • Universal LED • Standard function: RxD (green for data transfer) • Function depends on protocol or application, possible colors are: red, yellow, green • Rx blinks green when inbound data traffic is active 																											

Table 3-9 COM interface

3.3.5 S₀ interfaces



Image 3-14 S₀ interfaces

Element	Description
S ₀ A S ₀ B S ₀ C S ₀ D	<p>RJ45 jack with S₀ for connectivity to the PBX:</p> <p>Pin assignment:</p> <div style="display: flex; align-items: center;"> <div style="margin-right: 10px;"> <p>8 7 6 5 4 3 2 1</p> </div> <div style="text-align: center;"> <p>RJ45</p> </div> <div style="margin-left: 10px;"> <p>Pin 1: n.c. Pin 2: n.c. Pin 3: Tx+ Pin 4: Rx- Pin 5: Rx+ Pin 6: Tx- Pin 7: n.c. Pin 8: n.c.</p> </div> </div> <p>Input resistance:</p> <ul style="list-style-type: none"> S₀ 100 Ω
LED 1	<p>Status indicator Layer 1 and 2:</p> <ul style="list-style-type: none"> OFF Layer 1, Layer 2 inactive red Layer 1 inactive yellow Layer 1 active, Layer 2 inactive green Layer 1 and Layer 2 active green blinking Layer 1 inactive, Layer 2 active
LED 2	<p>Status indicator Layer 3:</p> <ul style="list-style-type: none"> OFF Layer 3 inactive yellow Layer 3 active (all B-channels occupied) green Layer 3 active (at least 1 B-channel occupied)

Table 3-10 S₀ interface

3.3.6 E₁/T₁ interfaces



Image 3-15 E₁/T₁ interfaces

Element	Description
E ₁ /T ₁ A E ₁ /T ₁ B	<p>RJ45 jack with E1/T1 for connectivity to the PBX: Pin assignment:</p> <div style="display: flex; align-items: center;"> <div style="margin-right: 20px;"> <p>8 7 6 5 4 3 2 1</p> </div> <div> <p>Pin 1: Rx+ Pin 2: Rx- Pin 3: n. c. Pin 4: Tx+ Pin 5: Tx- Pin 6: n. c. Pin 7: n. c. Pin 8: n. c.</p> </div> </div> <p>Input resistance:</p> <ul style="list-style-type: none"> • E₁ 120 Ω • T₁ 100 Ω
LED 1	<p>Status indicator Layer 1 and 2:</p> <ul style="list-style-type: none"> • OFF Layer 1, Layer 2 inactive • red Layer 1 inactive • yellow Layer 1 active, Layer 2 inactive • green Layer 1 and Layer 2 active • green blinking Layer 1 inactive, Layer 2 active
LED 2	<p>Status indicator Layer 3:</p> <ul style="list-style-type: none"> • OFF Layer 3 inactive • yellow Layer 3 active (all B-channels occupied) • green Layer 3 active (at least 1 B-channel occupied)

Table 3-11 E₁/T₁ interface

3.3.7 USB-Service interface



Image 3-16 USB-Service interface

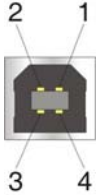
Element	Description
USB service	<p>USB plug type B: Pin assignment:</p> <div style="display: flex; align-items: center; justify-content: center;">  <div style="margin-left: 20px;"> <ul style="list-style-type: none"> • Pin 1: V_{Bus} • Pin 2: D- • Pin 3: D+ • Pin 4: GND </div> </div>

Table 3-12 USB-Service interface



Caution!

Before you connect A31003S1850S101017620 to a service PC, make sure you have installed the proper USB driver first. See "User Manual"



Caution!

For the operation with the USB port, A31003S1850S101017620 requires an external power supply.

The USB-Service interface can NOT be used as power or voltage supply for A31003S1850S101017620.

See Section 3.2.1 "Power supply AC"

See Section 3.2.2 "Power supply DC"

3.3.8 USB device interfaces



Image 3-17 USB-Device interfaces

Element	Description
USB A USB B	<p data-bbox="545 533 753 568">USB plug type A:</p> <p data-bbox="545 568 740 604">Pin assignment:</p> <div data-bbox="600 689 769 824"> </div> <ul data-bbox="836 631 1200 770" style="list-style-type: none"> • Pin 1: V_{Bus} • Pin 2: D- • Pin 3: D+ • Pin 4: GND <p data-bbox="545 882 753 918">Technical details:</p> <ul data-bbox="545 918 1254 990" style="list-style-type: none"> • U_{max} 5 V DC • I_{max} 500 mA per interface

Table 3-13 USB device interface

3.4 Last fault signaller **MARS (= Major-Alarm-Remote-Signaller)**

3.4.1 Functionality

- Visual and audible fault message (red LEDs and sound signaller) in case of:
 - OScAR malfunction
 - power failure
 - line break (between OScAR server and remote MARS signaling unit)
MARS-Signalisierungseinheit)
 - in monitoring mode in case of hanging fault signal relays in the OScAR server (2 variants: with and without this detection)
- Time-limited loud and clearly visible main fault signaling (30 min. long) with immediate silencing option by button press, followed by fault reminder signaling
mit Sofort-Silencing-Option per Tastendruck, anschließend Störungs- Erinnerungssignalisierung
- Automatic reactivation after fault removal
- Power supply normally from OScAR server (2-wire line for power supply and error message with max. line length of 500 m); in case of power failure power supply from internal lithium battery
- Status output "Device active and external power supply okay" via green LED
- Low battery warning via red LEDs and sound signaling
- Test function by keystroke
- Small round design (like a fire detector)
- Wall installation (surface mount with magnetic holder) or table placement (with rubber stands)

3.4.2 Product Component MARS adapter

- Order number MARS adapter, without relay function: TNK:MARS-A
- Bestellnummer MARS-Adapter, mit Relais-Funktion: TNK:MARS-AR
- Funktion: Bewertung des OScAR 200-Störmeldekontakts und Senden des Okay- bzw. Störungssignals inkl. Speisung an das MARS-Signalisierungsmodul MARS-S; Stromversorgung aus 5V DC.



Image 3-18 MARS-Adapter

3.5 Add ons

3.5.1 DC power supply unit

- Order number: TNK:EPS-10
- Function: Power supply of OScAR 200 via an external AC/DC PSU.

Technical details:

- Input voltage: 100 ... 240VAC at 47-63Hz
- max. power consumption: 1.9 A
- Output voltage: 48V
- max. output current: 1.66 A



Image 3-19 AC/DC power supply unit

Pin assignment:

PIN	Function
A1	- DC
A2	GND
A3	+ DC

Table 3-14 AC/DC power supply unit - Pin assignment

3.5.2 Digital I/O



Caution!

The IOG Modules are available in the versions IOG-03 and IOG-03A.

The IOG Modules are available in the versions IOM-02, IOM-11, IOM-02A, and IOM-11A.

Note that you may only connect the IOM-02 and IOM-11 modules to the IOG-03 module.

Note that you may only connect the IOM-02A and IOM-11A modules the IOG-03A module.

Failure to follow these instructions can result in malfunctions.

3.5.2.1 Gateway

- Order number: TNK:IOG-03 or IOG-03A
- Function: Gateway to connect the IOM boards
See Section 3.5.2.2 "I/O Module Standard"
See Section 3.5.2.3 "I/O Module Secure"

Technical details:

Module	Element	Description
	USB	<ul style="list-style-type: none"> • Jack Type B • Connection to A31003S1850S101017620 via USB cable See Section 3.8.4 "USB cable cord"
	Status	Status indicator: <ul style="list-style-type: none"> • OFF no voltage • red no communication between Gateway and OScaR 200 for over 2 s • yellow currently booting and self-test • green OK

Table 3-15 Gateway for USB connection



Caution!

Before you plug in (connect) or disconnect the IOG and IOM modules, always make sure you cut the connection to OScaR 200 first.

See Section 3.5.2.2 "I/O Module Standard"

See Section 3.5.2.3 "I/O Module Secure"

Add ons

3.5.2.2 I/O Module Standard

- Order number: TNK:IOM-02 or IOM-02A
- Function: Connection for 8 digital signals without short circuit or line break detection, and 2 digital outputs

Technical details:


Module	Element	Description
	U- U- U- U- (internally connected)	GND
	INPUT 1..8	Digital inputs <ul style="list-style-type: none"> • electrically isolated • common negative pole • R_{IN} 15 kΩ • Internal feeding 12 V DC
	OUT 1a, 1b, 2a, 2b	Digital outputs <ul style="list-style-type: none"> • electrically isolated, also from one another • U_{max} 60 V • I_{max} 100 mA • R_{ON} 11 kΩ
	Status	Status indicator <ul style="list-style-type: none"> • OFF no voltage • red no communication between the I/O module (IOM) and the Gateway (IOG) • green OK

Table 3-16 I/O Module Standard

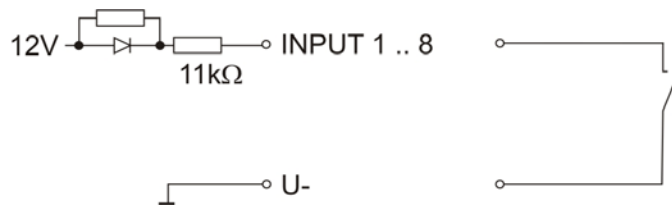


Image 3-20 Digital input wiring: Utilization of the internal voltage source, contact switching to minus

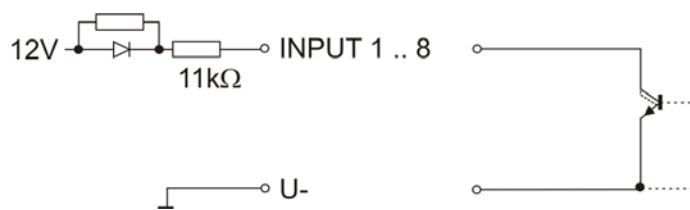


Image 3-21 Digital input wiring: Utilization of the internal voltage source, Open Collector

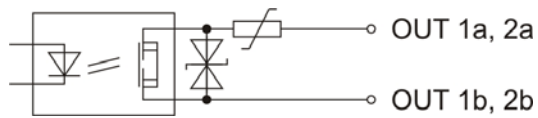


Image 3-22 Wiring of the digital outputs

Add ons

3.5.2.3 I/O Module Secure

- Order number: TNK:IOM-11 or IOM-11A
 - Function: Connection for 4 digital signals with short circuit- and line break detection, and 2 digital outputs
- Note:
IOM-11 is high impedance, if needed use $R = 5/12/24..60$ V

Technical details:

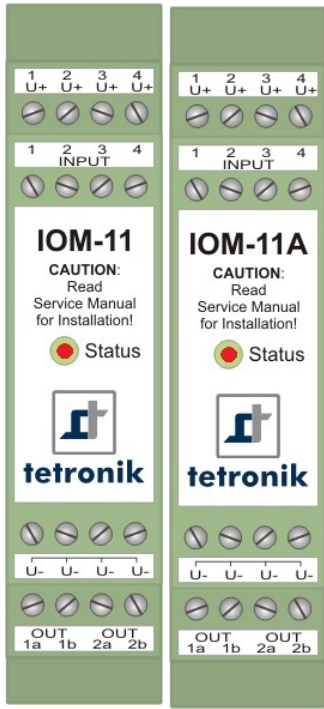
Module	Element	Description
	U+ 1..4	Power supplies <ul style="list-style-type: none"> • U 12 V • R_{int} 4.7 kΩ
	U- U- U- U- (internally connected)	GND
	INPUT 1..4	Digital inputs <ul style="list-style-type: none"> • electrically isolated • common negative pole • Switching thresholds 1, 6 and 10V DC For short circuit and line break detection in combination with external circuitry <ul style="list-style-type: none"> • R_{IN} 15 kΩ • Feeding Internal feed 12 V DC or external feed U_{max} 60 V DC
	OUT 1a, 1b, 2a, 2b	Digital outputs <ul style="list-style-type: none"> • electrically isolated, also from one another • U_{max} 60 V DC • I_{max} 100 mA • R_{ON} 11 Ω
	Status	Status indicator <ul style="list-style-type: none"> • OFF no voltage • red no communication between I/O module (IOM) and Gateway (IOG) • green OK

Table 3-17 I/O Module Secure

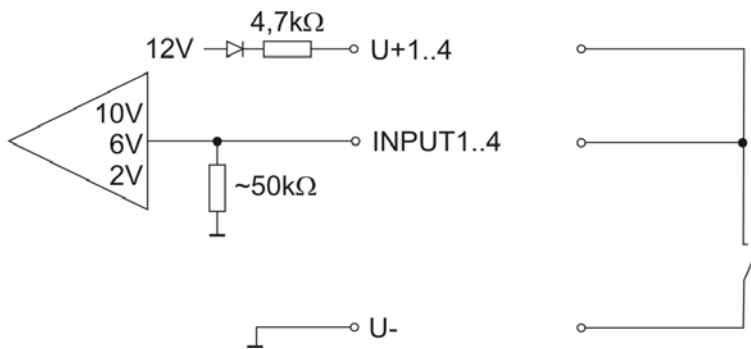


Image 3-23 Digital input wiring: Utilization of the internal voltage source, contact switching to minus, without line break detection

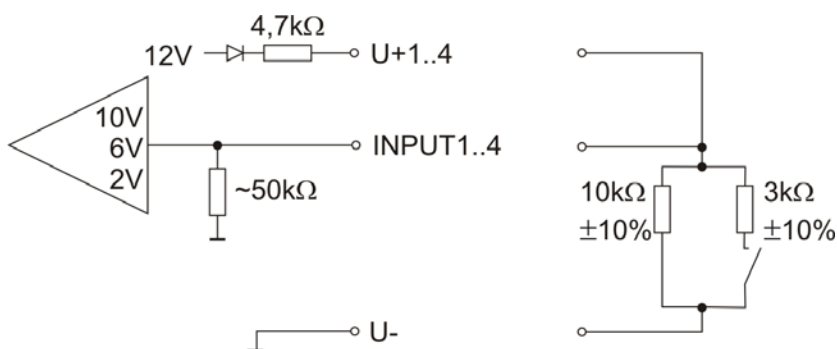
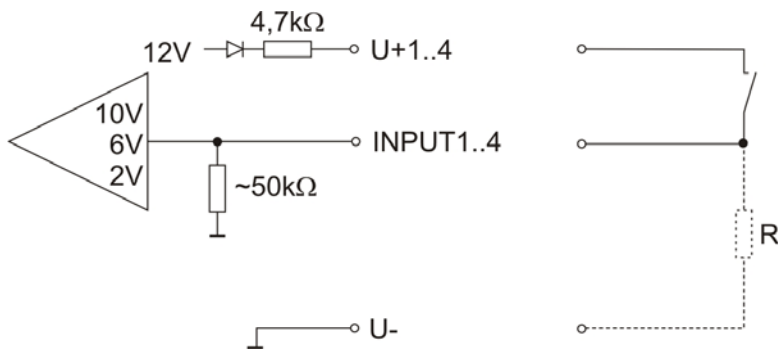


Image 3-24 Digital input wiring: Utilization of the internal voltage source, contact switching to minus, with line break detection



Note:
IOM-11 input is high impedance, if needed apply
 $R \sim 10k\Omega$

Image 3-25 Digital input wiring: Utilization of the internal voltage source, contact switching to plus, without line break detection

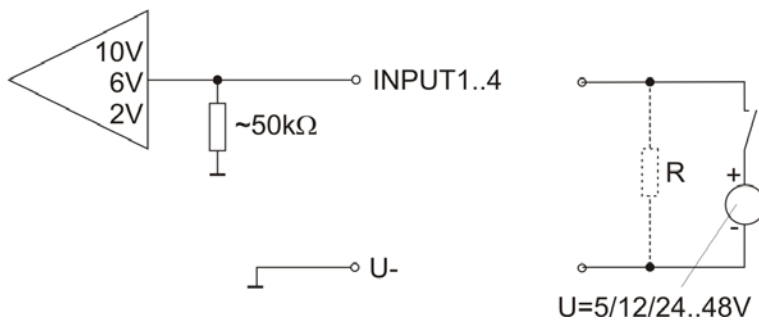


Image 3-26 Digital input wiring: Utilization of an external voltage source

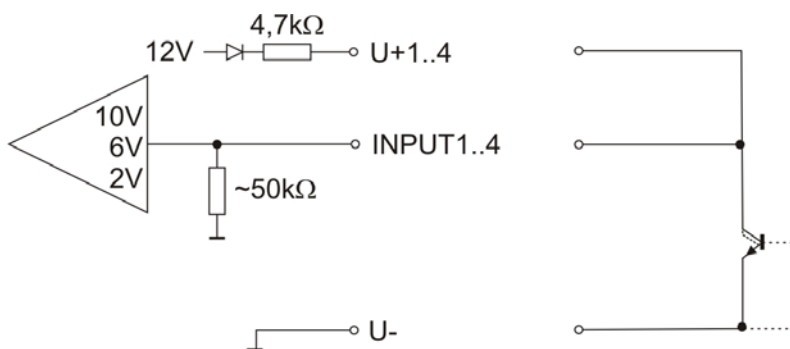


Image 3-27 Digital input wiring: Utilization of the internal voltage source, Open Collector without monitoring

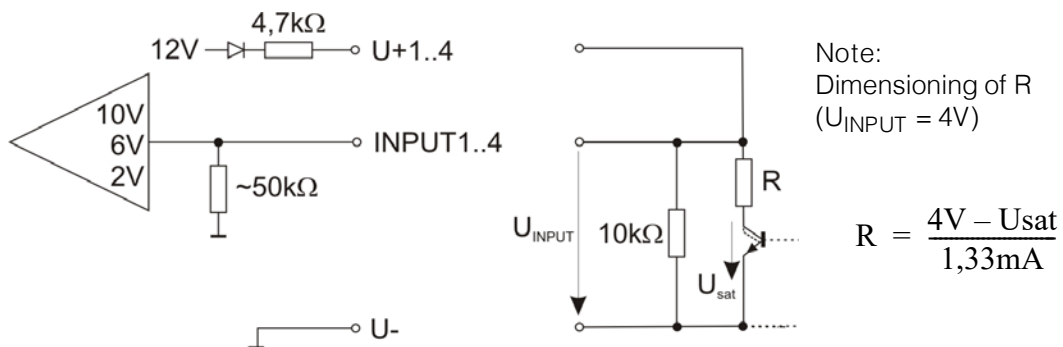


Image 3-28 Digital input wiring: Utilization of the internal voltage source, Open Collector with monitoring

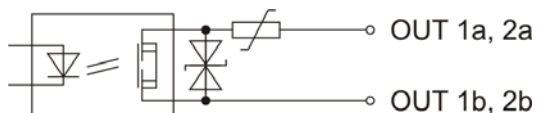


Image 3-29 Wiring of the digital outputs

3.5.3 DCF-77 radio receiver

- Order number: TNK:AD450 or AD650
- Function: Radio receiver to synchronize OScAR 200 with the statutory time of the Federal Republic of Germany

Technical details:

- Measurements: Length 65 mm
Depth 35 mm
Height 90 mm (with connection plate)
- Cable length: 10 m
- Cable extension: max. 200 m
Cable properties: 2-wire twisted pair cable cord, minimum cross section 2 x 0.25 mm²

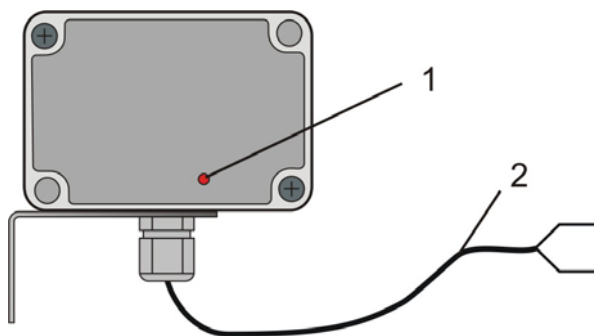


Image 3-30 AD450 or AD650: DCF-77 radio receiver

Element	Description
1	Status indicator: <ul style="list-style-type: none"> • OFF No power supply from the connection cable • Blinking 1x per s Good radio reception • Flickering Interference of the radio reception
2	Connection cable open at both ends for connectivity to OScAR 200. See Section 3.2.5 "Connection of the DCF receiver"

Table 3-18 AD450 or AD650: DCF-77 radio receiver

Please follow the below instructions when you install the DCF-77 radio receiver:

- Mount the apparatus as high up as possible and not in buildings with exterior walls that are highly insulated and shielded, nor in buildings with a metallic roof construction.
- Minimum distance from sources of interference 2-3 m.
- Mount the reception housing horizontally.
- If necessary, shorten the connection cable to avoid an antenna effect.
- After the connection is made and the receiver is adjusted, wait 30 seconds before assessing the radio reception.

Add ons

3.5.4 USB/RS232 interface

- Order number: TNK:USB/RS232-0X
- Function: Adapter to convert a RS232 interface to USB for connectivity to a USB-device interface.

3.5.5 CompactFlash card

- Order number: TNK:MD-CF2-4G
- Function: Mass storage device in OScAR 200.
It is here that all non-volatile data is stored that is needed for the proper operation of OScAR 200 (e.g. the operating system, driver, license information, applications, announcements etc).

Technical details:

- Storage capacity: 4 GB



Caution!

The CompactFlash card TNK:MD-CF2-4G may NOT be replaced with any other commercially available CompactFlash card!

3.5.6 Printer

- Order number:
 - TNK:LP-OML280-2
with USB- and Centronics interface
 - TNK:LP-OML280-2S
with RS232- and USB port
(LP-OML280-2 with built-in OML280S)
 - TNK:OML280S
RS232 interface module for dot-matrix printer
 - TNK:USB/RS232-01
USB/RS232 interface
 - TNK:A-CTXLAN1
LAN adapter

- Function:
 - Protocol printer for direct connectivity to OScaR 200 via RS232 or USB



Note:

For more details on OKI Microline 280 and the mounting of the interface module for RS232, please see the installation/documentation CDs included in the printer's delivery package.

The printer automatically detects if it is running on a a serial or on a USB port.

The DIL switches that are covered below are only of relevance if the printer is operated on one of the serial interfaces.

Make sure the DIL switches on the interface board are configured as described in Image 3-31 or Table .

See the printer manual.

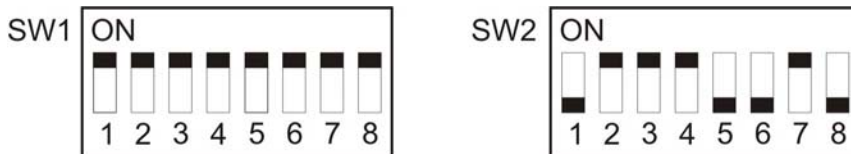


Image 3-31 Position of DIL switches on the interface board

Element	Default setting	Description
SW1		
1	ON	No parity
2	ON	
3	ON	Data format 8 bits
4	ON	Busy/ready report
5	ON	Normal printer mode, no test mode
6	ON	
7	ON	Busy signal via Pin 20
8	ON	

Table 3-19 Position of DIL switches on the interface board

Element	Default setting	Description
SW2		
1	OFF	Transmission rate 9600 baud
2	ON	
3	ON	
4	ON	Printer spooler in system, printer operating in handshaking mode
5	OFF	Busy signal active when space for only 256 characters remains in buffer
6	OFF	Busy timing 2
7	ON	do not change
8	OFF	

Table 3-19 Position of DIL switches on the interface board

How to specify the printer default settings, step by step:

- see "OKI User Manual" on the installation CD"

Step	Description
1	Press the SELECT key, keep it pressed and power on the printer. The LEDs 12 and UTILITY will start blinking.
2	Press the SELECT key for a printout of the entire menu. You will receive a complete list of the current default settings.
3	Press the key LINE FEED to select the group you want to edit (you will find the group in the left-hand column on the menu printout).
4	Press the FORM FEED key to select the relevant element of the group you have chosen (you will find the element in the center column of the menu printout).
5	Press the TOF SET key to browse the element settings that you want to edit (you will find these settings in the right-hand column of the menu printout).
6	After you have invoked the wanted setting, press the LINE FEED key (for the next group) or the FORM FEED key (for the next element) that you want to edit. Follow steps den 3 to 5 until you have added all the changes you want to make.
7	After you have completed all the changes, press the PITCH key (width) plus the MODE key (mode) at the same time to close the mode and to save all the changes you have made.

Table 3-20 Printer default settings



Note:

Be careful not to end the menu mode by switching off the printer. Otherwise your changes will not be saved.

The following settings must be made:

- Column width for best printout
 - Font - Pitch 17.1 CPI (default = 10 CPI)
- German special characters
 - Symbol Sets - Code Page ISO 8859-15 (default = USA)

3.6 Line extensions

3.6.1 CSA converter

- Order number: TNK:CSA-01
- Function: To convert an RS-422 interface into an RS-232 interface- See Section 5.8 "Line extension of the COM interface"

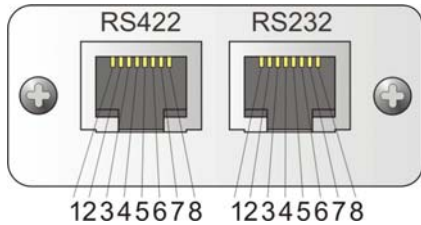


Image 3-32 The CSA-Converter

Pin assignment RS422:	Pin 1:	n. c.
	Pin 2:	Rx+/A
	Pin 3:	GND
	Pin 4:	Rx-/B
	Pin 5:	Tx+/Y
	Pin 6:	n. c.
	Pin 7:	Tx-/Z
	Pin 8:	n. c.
Pin assignment RS232:	Pin 1:	DSR
	Pin 2:	RTS
	Pin 3:	GND
	Pin 4:	TxD
	Pin 5:	RxD
	Pin 6:	DCD
	Pin 7:	CTS
	Pin 8:	DTR



Note:
The CSA adapter is powered through the RS-232 connection and requires no further electric power supply. Make sure the handshake lines are connected at the RS-232 device (host, modem).

3.6.2 SMS radio modem

- Order number: TNK:FM-SMS1
- Function: Dispatch of SMS messages via GSM modem



Note:
For further details on how to use the dialing modem please see the User Manual.

3.6.3 Transmission kit for OScAR 200 to printer

- Order number: TNK:V2X-90-WPZ104
- Function: Connection on the side of OScAR 200, to link-up a printer to OScAR 200 via the USB/RS232 interface through a line extension. See Section 3.5.4 "USB/RS232 interface"

Technical details:

- Cable length: 10 m

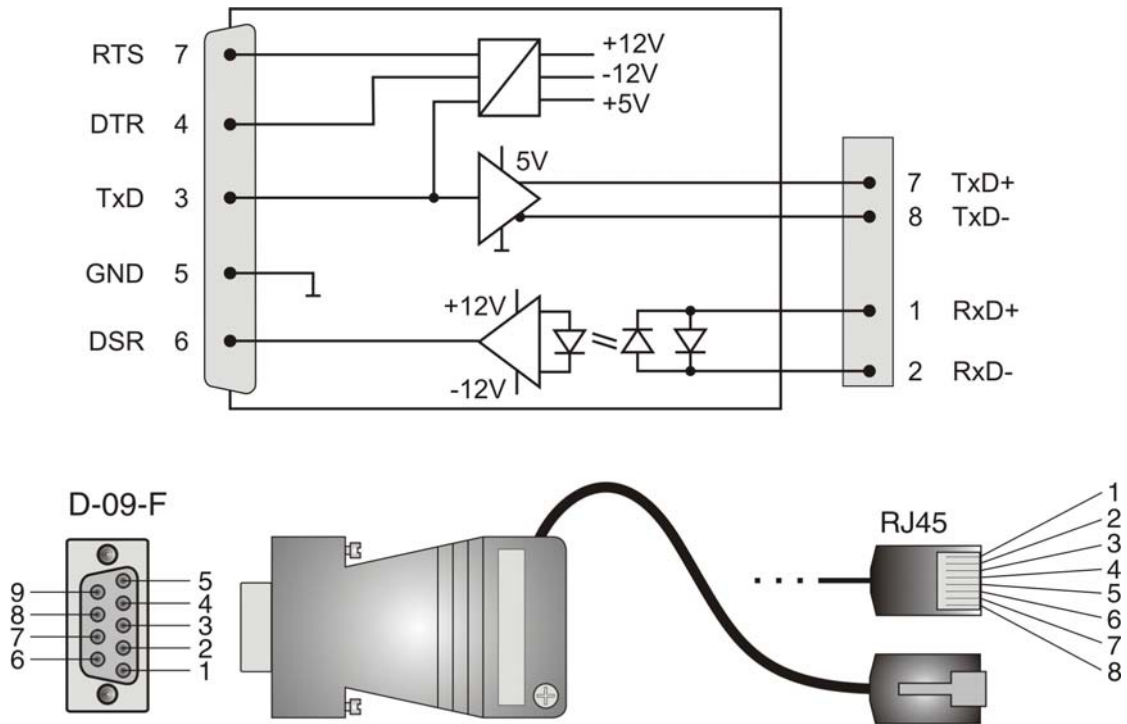


Image 3-33 Transmission kit for OScAR 200 to Printer

3.6.4 Transmission kit for printer

- Order number: TNK:VX2-WPZ104
- Function: Connection on the side of the printer, to link-up a printer to OScAR 200 via the USB/RS232 interface through a line extension. See Section 3.5.4 "USB/RS232 interface"

Technical details:

- Cable length: 5 m

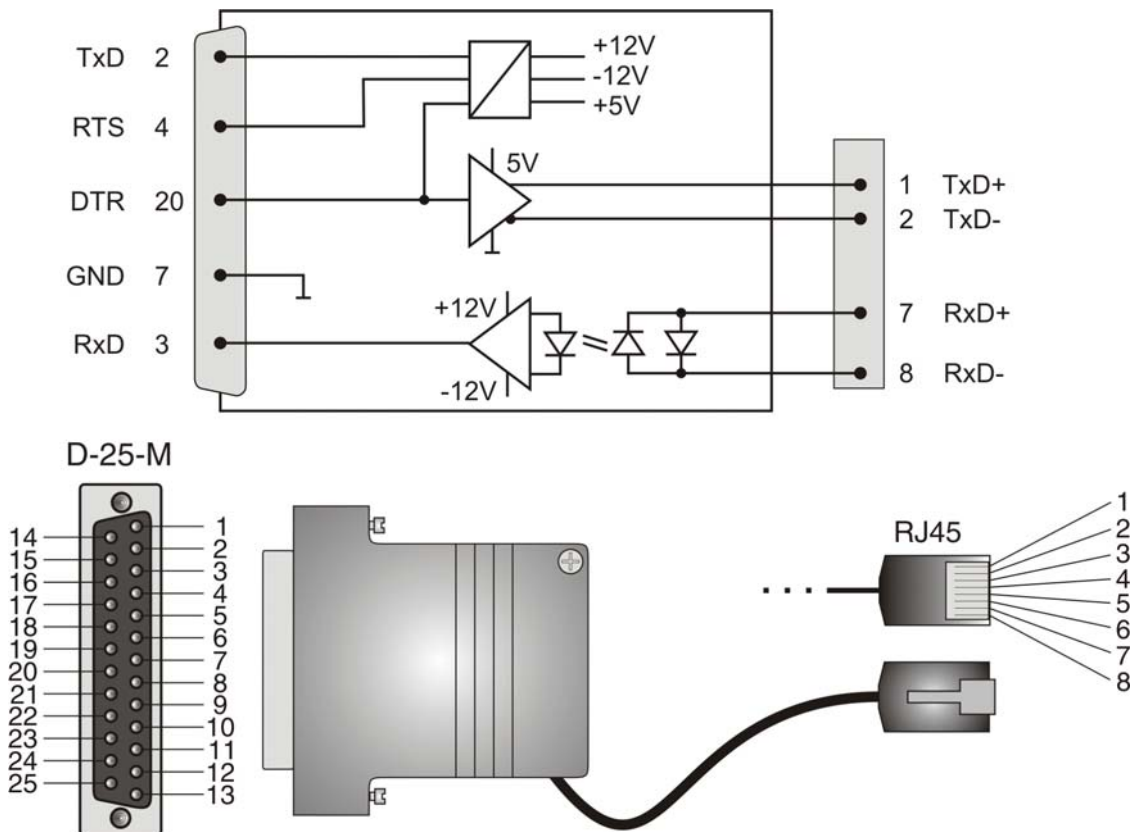


Image 3-34 Transmission kit for printer

3.7 General adapters

3.7.1 DCE adapter

- Order number: TNK:A-DCE-01
- Function: Adapter from RJ45 to SUB D-09-F to connect OScAR 200 to a DTE (for example to a PC), with local handshake
▶see Chapter 5, "Wiring Plans"

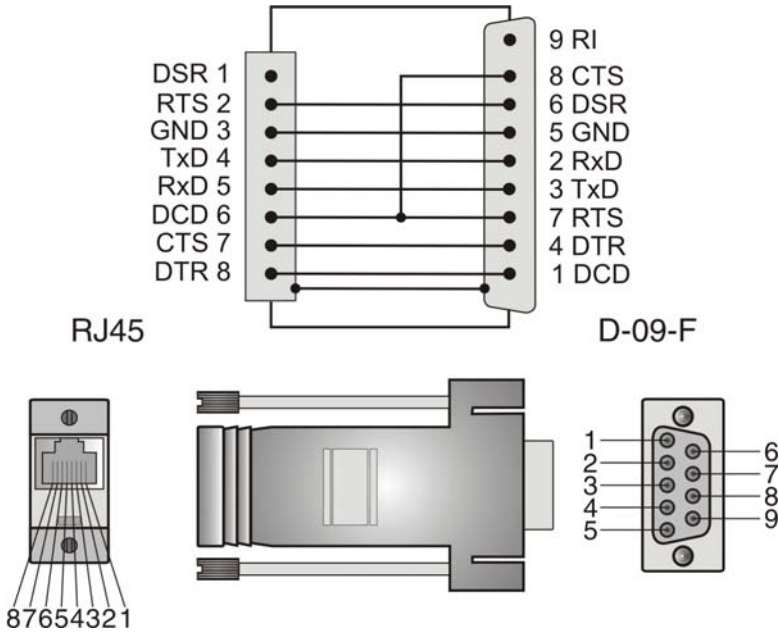


Image 3-35 DCE adapter with a local handshake

3.7.2 DTE adapter

- Order number: TNK:A-DTE-01
- Function: Adapter from RJ45 to SUB D-09-M to connect OScAR 200 to a DCE, e.g. a modem. See Chapter 5, "Wiring Plans"

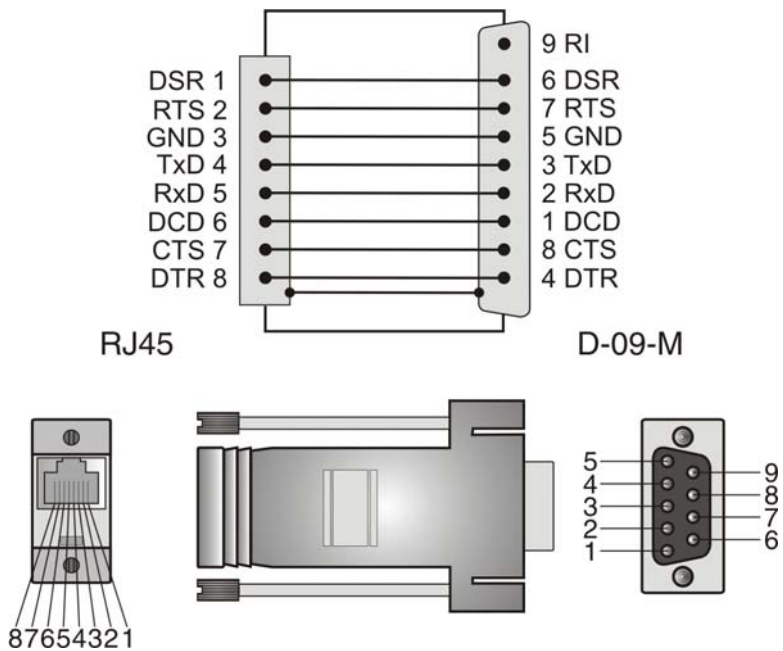


Image 3-36 DTE adapter

3.7.3 PRN adapter

- Order number: TNK:A-PRN-01
- Function: Adapter from RJ45 to SUB D-15-M to connect OScAR 200 to a Unify PBX system (OpenScape). See Section 5.5 "ISDN E1/T1 interface"

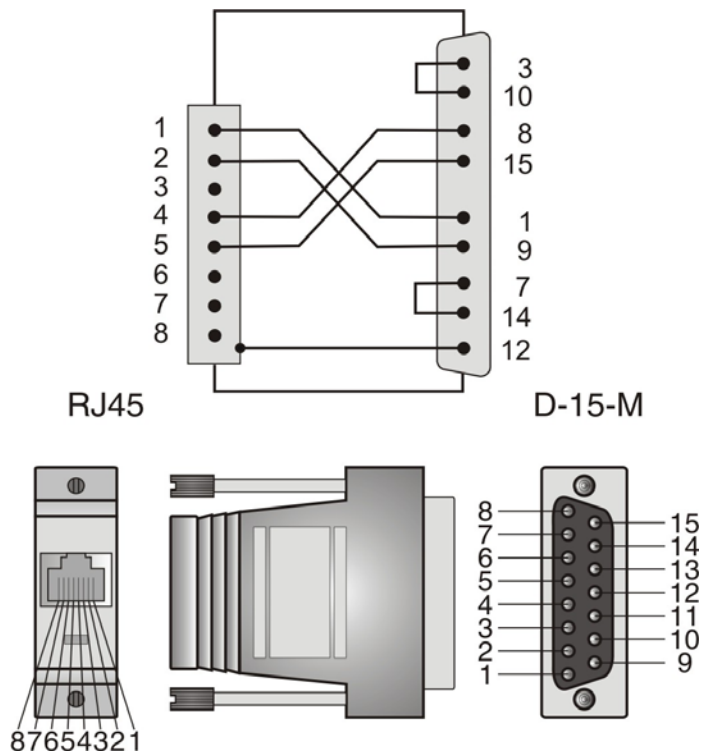


Image 3-37 PRN adapter

3.7.4 PRT adapter

- Order number: TNK:A-PRT-01
- Function: Adapter from RJ45 to SUB D-15-M to connect OScAR 200 to a Unify PBX (HiPath), via a Unify S_{2M} cable cord 530267-Z88-A100.

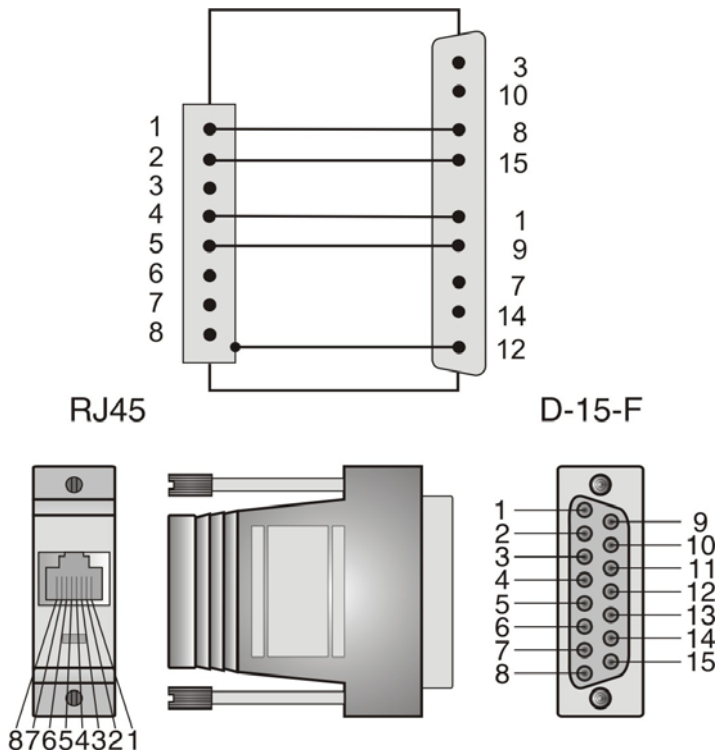


Image 3-38 PRT adapter

3.7.5 Twin outlet line jack unit S₀ (shielded)

- Order number: TNK:UAE/8/8AP-S
- Function: To connect OScAR 200 to a PBX
➤ see Section 5.6 "ISDN S₀ interface"

The Pin assignment of the RJ45 socket results from the interface to which it is connected.

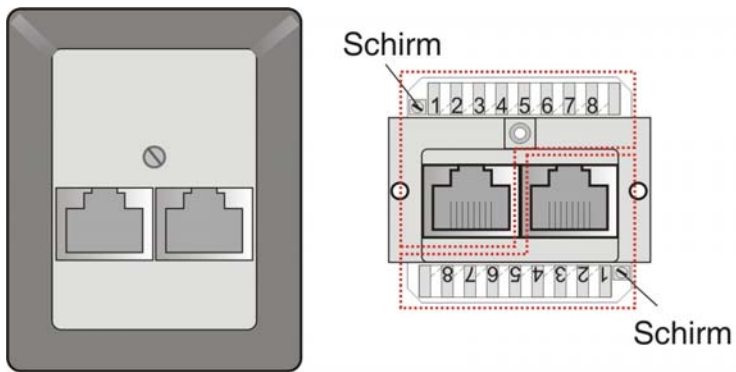


Image 3-39 Twin outlet line jack unit S₀ (shielded)

3.7.6 Single outlet line jack unit RS422 (unshielded)

- Order number: TNK:UAE8AP
- Function: The single socket is used for line extension via RS422See Section 5.8 "Line extension of the COM interface".

The Pin assignment of the RJ45 socket results from the interface to which it is connected.

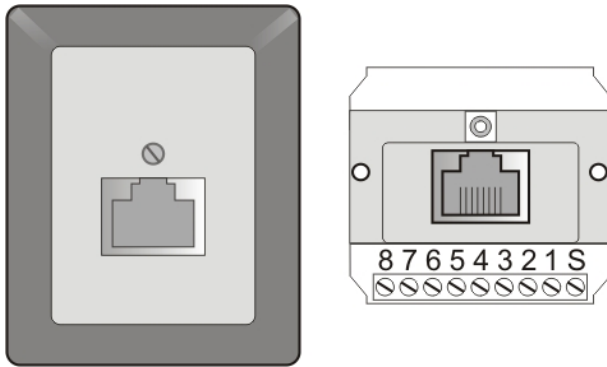


Image 3-40 Single outlet line jack unit RS422 (unshielded)

3.7.7 Patch field

- Order number: not available
- Function: Connect external components to OScAR 200.

The patch field can be used analogous to the RJ45 jack.

See Section 3.7.6 "Single outlet line jack unit RS422 (unshielded)"

3.8 General cable cords

3.8.1 DC power supply cable

- Order number: TNK:K-51001-0600
- Function: DC connector cable for OScAR 200

Technical details:

- Length 6 m

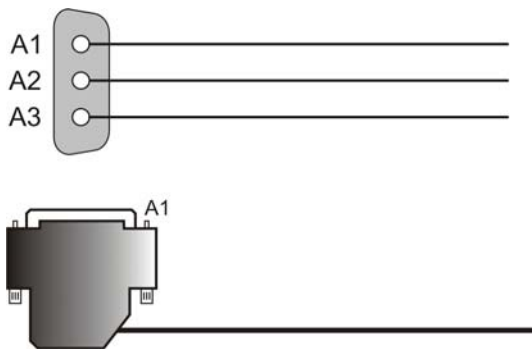


Image 3-41 DC power cord

Pin assignment:

PIN	Function	Color
A1	- DC	blue
A2	GND	green-yellow
A3	+ DC	brown

Table 3-21 DC power cord - Pin assignment

3.8.2 AC connector cable Germany

- Order number: TNK:K-AC-D-0180
- Function: AC connector cable for OScAR 200

Technical details:

- Length 1.80 m
- Connection: Plug for Germany

3.8.3 AC connector cable USA

- Order number: TNK:K-AC-US-0250
- Function: AC connector cable for OScAR 200

Technical details:

- Length 2.50 m
- Connection: Plug for USA

3.8.4 USB cable cord

- Order number: TNK:K-USBAB-0300
- Function: To connect OScAR 200 to a service PC, a digital I/O or a printer.

Technical details:

- Length 3.00 m
- Connection: Plug type A/B

3.8.5 Patch cable cord

- Order number: TNK:K-CAT6-0300
- Function: Connector cable to link up various interfaces (e.g. LAN, RS232, RS422, S₀, E1(S_{2M}), T1)

Technical details:

- Length 3.00 m
- Category: CAT6, shielded
- PIN assignment In keeping with EIA/TIA T568A or EIA/TIA T568B, resp.

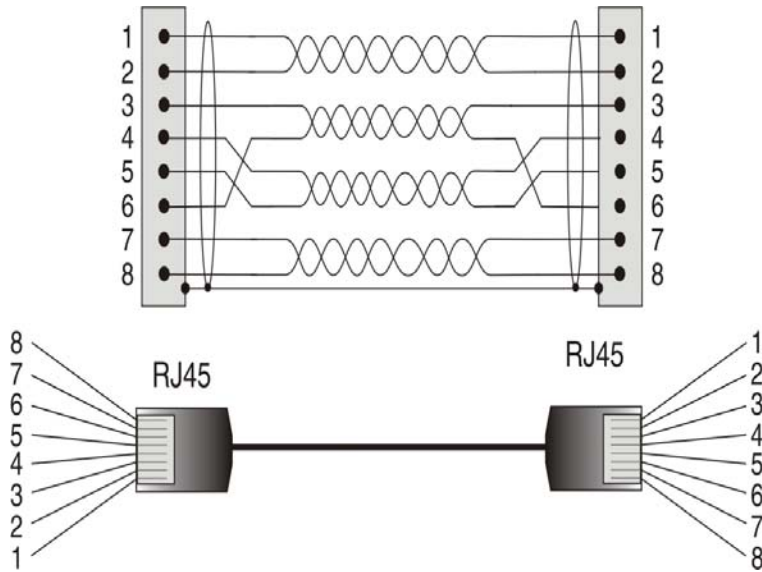


Image 3-42 Patch cable cord

3.8.6 RS232 data cable cord

- Order number: TNK:K-10225-0500
- Function: Cable cord to connect the RS232 output of the CSA converter (including the DC jack) for link-up of a power adapter (TNK:NT-CSA-0X) in order to feed the CSA converter
➤see Section 3.6.1 "CSA converter"

Technical details:

- Length 3 m

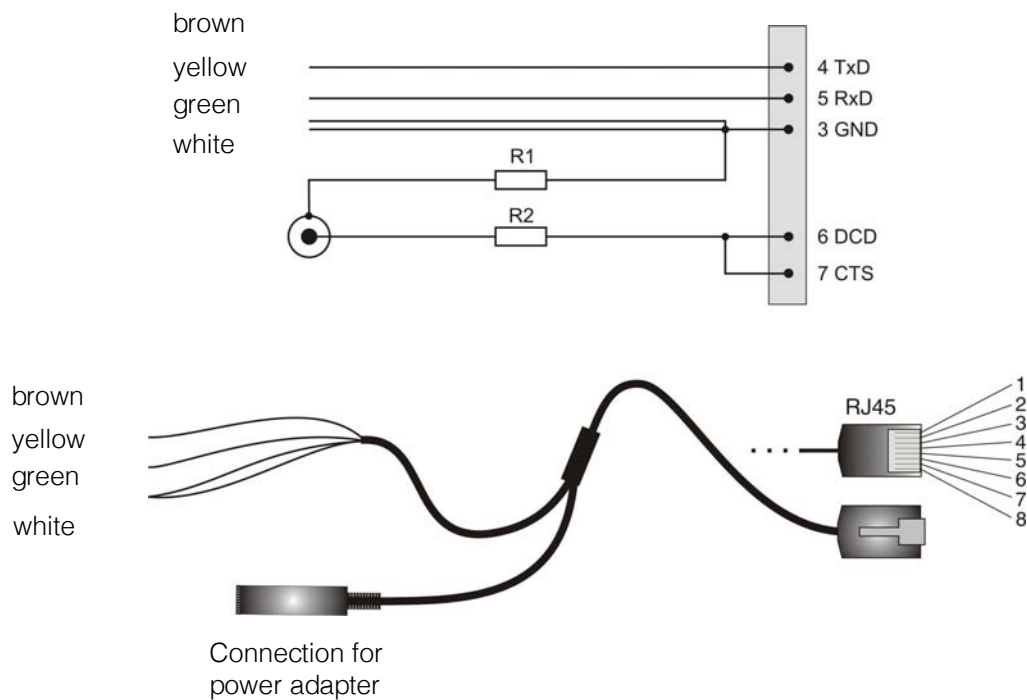


Image 3-43 RS232 data cable cord

4 Hardware Operations

Overview

This chapter describes the hardware operations on the server and also includes the safety instructions in German, Finnish, Danish and Swedish.

4.1 General safety instructions



Note:

Fire security and life safety features were not evaluated during the UL test.



Warning!

Always make sure you read the installation instructions carefully before you connect the system to the electric power source.



Warning!

Please follow the general safety instructions and the recommended measures for ESD protection.



Warning!

A31003S1850S101017620 may not be operated in explosion-risk areas or rooms.



Warning!

During a thunderstorm, do not perform any operations on the system and do not connect or pull any cables or cords.



Warning!

The sockets labelled "ETHERNET", "USB", "COM", "DCF" and "Relay" are safety switches with an extra low voltage (Safety Extra Low Voltage, SELV). Always make sure that SELV switches are only connected to other SELV switches.



Warning!

The sockets marked "S₀" and "E1/T1" are safety switches with TNV-1 circuits.



Warning!

A31003S1850S101017620 is designed for operation in an EDP or lab environment and requires a surrounding that is dry, clean, well-ventilated, and air conditioned. A31003S1850S101017620 is cooled exclusively by way of convection, i.e. no fans are built into A31003S1850S101017620.

For more details on the required ambient temperature and the humidity:

➤ see Chapter 3, "Product Components".



Warning!

A31003S1850S101017620 may only be repaired or serviced by the producer and with the original parts.

No components or parts of the boards may be replaced or exchanged by the user.



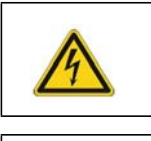
Warning!
This product may only be disposed in keeping with the pertinent statutory laws and regulations.
Note: A31003S1850S101017620 optionally contains a lithium battery, the disposal of which must be in accordance with the regulations that are currently in force in the country in which the system is used.



Warning!
The casing may only be opened by the trained engineers. Before the casing is opened, all power supply connections must be cut (AC and DC).



Warning!
This unit may have double pole/neutral fusing. The fuses may only be replaced by the manufacturer.



Warning!
All hardware operations at OScAR 200 must be according to the instructions in the manuals.



Warning!
OScAR 200 may not be used to monitor patients while any of these processes are being performed:

- upgrades
- updates of the software
- import of licenses
- changes of the VCON parameters that require a reboot of the system



Warning!
OScAR 200 conform to the protection class I.
To avoid the risk of electric shock, this device should only be connected to a power supply with a protective earth conductor.



Note:
OScAR 200 is intended and qualified for continuous operation!



Note:
If the power plug or device plug is used as a disconnecting device, the plug must remain freely accessible.

4.2 Safety instructions OScAR



Warning!

OScAR may only be installed in the control cabinet together with other devices that have passed an electromagnetic compliance test (EMC)!



Note:

There are no known contraindications for OScAR.

4.3 Safety instructions for Denmark



Vigtigt!

Apparatets stikprop skal tilsluttes en stikkontakt med jord som giver forbindelse til stikproppens jord.



Vigtigt!

Lederen med grøn/gul isolation må kun tilsluttes en klemme mærket (IEC 417, No. 5019) eller (IEC 417, No. 5017).

For tilslutning af de øvrige ledere, se medfølgende installationsvejledning".

4.4 Safety instructions for Norway



Advarsel!

Apparatet må tilkoples jordet stikkontakt.

4.5 Safety instructions for Finland



Variotus!

Laite on liitettävä suojamaadoituskoskettimilla varustettuun pistorasiaan.

4.6 Safety instructions for Sweden



Varning!

Apparaten skall anslutas till jordat uttag.

4.7 Installation and replacement of ISDN modules in OScAR 200

Follow the below instructions to install or replace ISDN modules in OScAR 200.

Typical operations are:

- the installation of an ISDN module following a retrofit from a VoIP- to a TDM/ISDN connection,
- the replacement of a defect ISDN module, or
- the replacement of an S₀ module with 4 ports with an E1(S_{2M})/T1 module with 2 ports, in combination with a channel upgrade.



Warning!

Make sure you pull ALL power cables before you start any servicing work on OScAR 200.



Warning!

Please follow the general safety instructions and the recommended measures for ESD protection.

How to install or replace ISDN modules in OScAR 200, step by step:

No.	Step
1.	<p>To install or replace the ISDN module in OScAR 200 you need:</p> <ul style="list-style-type: none"> • the replacement module you want to install (included in the in plug-and-play/replacement kit) • 2 module fastening screws (pan head M3x6 T101) (included in the plug-and-play/replacement kit) • if needed a replacement front panel (if needed, included in the plug-and-play/replacement kit) • 1 special Allen wrench (included in the plug-and-play/replacement kit) • 1 Torx wrench (included in the plug-and-play/replacement kit) • 1 crosstip screwdriver (<u>not</u> included in the plug-and-play/replacement kit)  <p>Image 4-1 Example of a plug-and-play/replacement kit for OScAR 200</p>

Table 4-1 Install or replace ISDN modules in OScAR 200

No.	Step
2.	<p>Start by unfastening the side fastening screws at the rear of the casing with a crosstip screwdriver and save the screws for later:</p> 
3.	<p>Carefully remove the casing cover by sliding it to the back and then upwards:</p> 

Table 4-1 Install or replace ISDN modules in OScAR 200

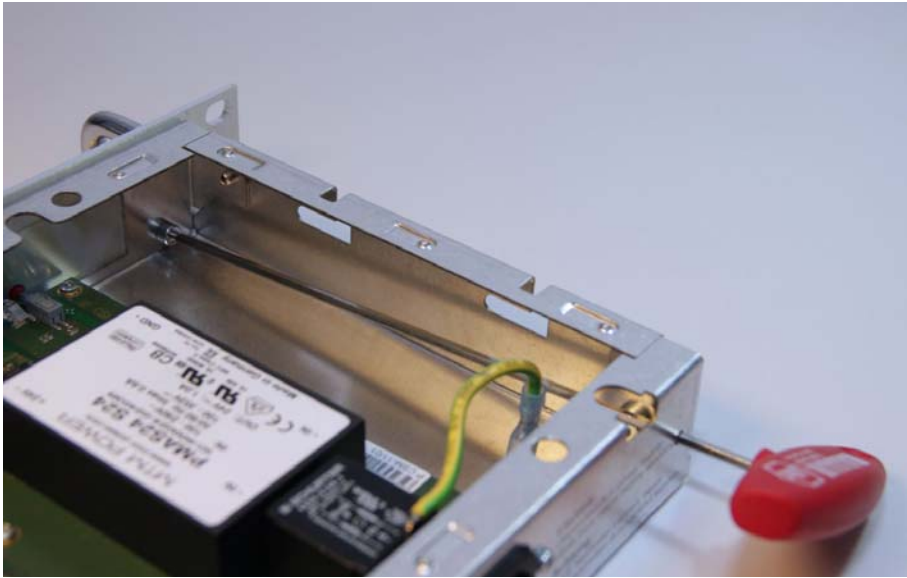
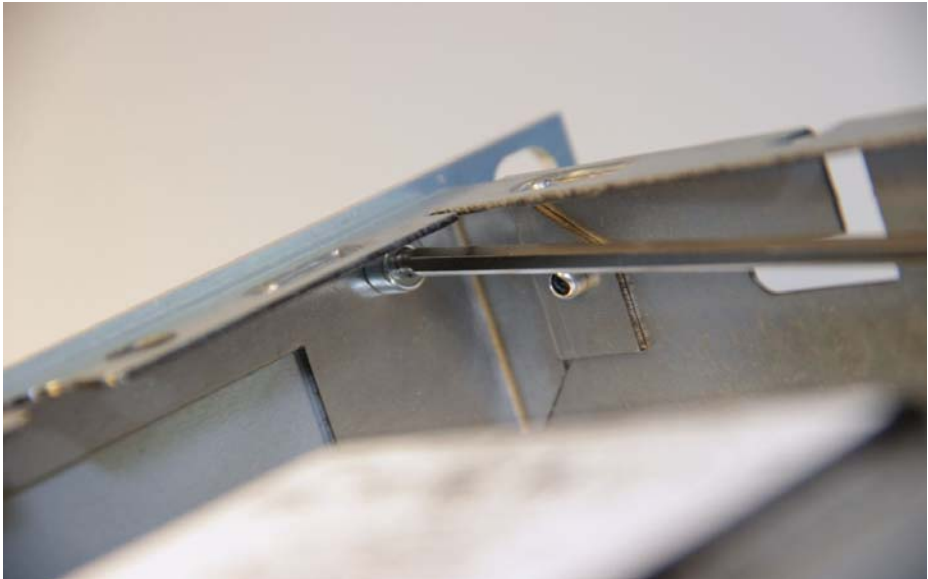
No.	Step
4.	<p>Next, unfasten the two lower screws at the rear side of the front panel using the special Allen wrench, and save the screws for later:</p> 
5.	<p>Now do the same with the two upper screws at the rear side of the front panel. Again, use the special Allen wrench and save the screws for later:</p> 

Table 4-1 Install or replace ISDN modules in OScAR 200

No.	Step
6.	<p data-bbox="418 271 1476 304">The two front handles (left and right) of the front panel will now fall off; save them for later:</p>  <p data-bbox="438 936 518 1030">  Caution! Before you remove the front panel in the next step, be particularly careful with the red Reset button and the light guide of the status LED (RES / STAT) so that neither of them accidentally snaps. </p> 

Table 4-1 Install or replace ISDN modules in OScAR 200

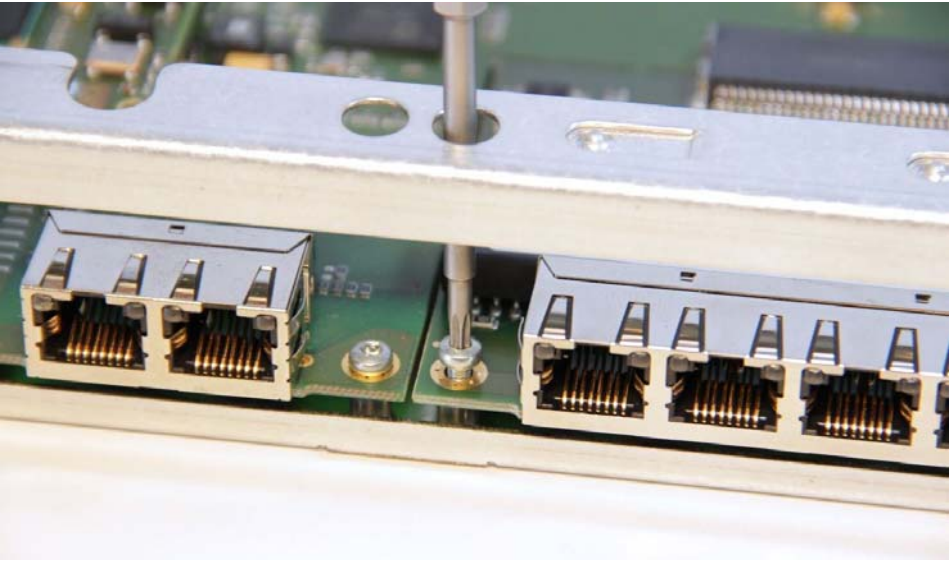
No.	Step
7.	<p>Carefully pull off the front panel straight to the front, and be sure you do not bend it downwards or upwards while doing so.</p> 
8.	<p>Applies only to a module replacement, not to a retrofit of the system from VoIP to TDM/ISDN: Use the Torx wrench to unfasten the two screws of the module you want to replace (here: S₀ module with 4 ports), and save the screws for later:</p> 

Table 4-1 Install or replace ISDN modules in OScAR 200



No.	Step
9.	<p>Applies only to a module replacement, not to a retrofit of the system from VoIP to TDM/ISDN:</p> <p>Next, carefully pull off the module you want to remove and replace (here: S₀ module with 4 ports), and make sure you pull it off parallel to the board.</p> 
10.	<p>Now install the new module (here: E1(S_{2M})/T1 module with 2 ports, shown on the right):</p> 

Table 4-1 Install or replace ISDN modules in OScAR 200

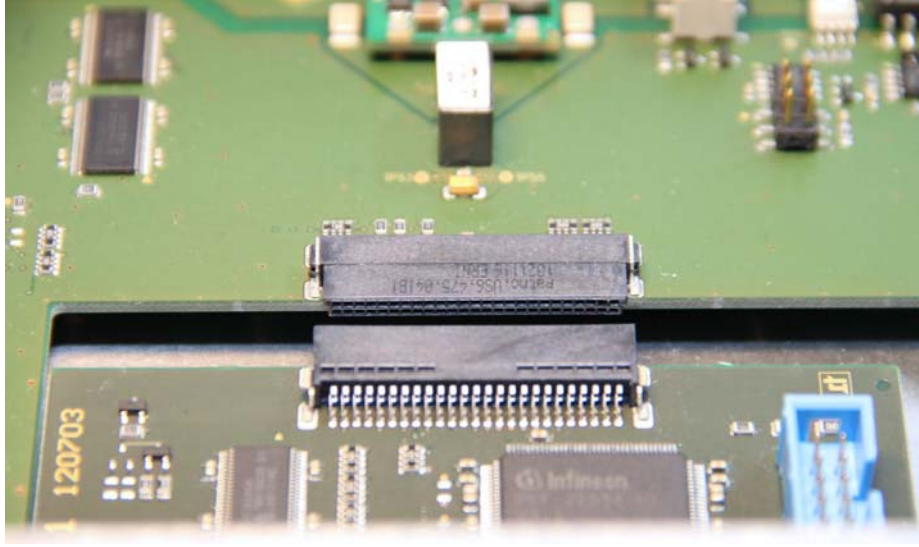

No.	Step
11.	<p>Make sure you install the module parallel to the board without canting it:</p> 
12.	<p>Fasten the new module on the left and right with the two module screws. Use the Torx wrench included in the kit:</p> 

Table 4-1 Install or replace ISDN modules in OScAR 200

No.	Step
13.	<p data-bbox="418 273 1476 338">Now fasten the front panel with the special Allen wrench (here: front panel for an E1(S_{2M})/T1 module with 2 ports).</p>  <p data-bbox="440 927 520 994"> Caution!</p> <p data-bbox="557 936 1476 1001">Again, be careful to install the front panel horizontally so that the red Reset button and the light guide of the status LED (RES / STAT) do not snap:</p> 
14.	<p data-bbox="418 1653 1366 1682">Replace the casing cover and fasten it to the body with the crosstip screwdriver.</p>

Table 4-1

Install or replace ISDN modules in OScAR 200

No.	Step
15.	The hardware conversion is now completed. 

Table 4-1 Install or replace ISDN modules in OScAR 200

5 Wiring Plans

Overview

This chapter covers the different wiring plans of OScAR 200.

Content

The following areas are covered in this chapter:

- 5.1 Power supply
- 5.2 USB service
- 5.3 Ethernet interface
- 5.4 USB port
- 5.5 ISDN E1/T1 interface
- 5.6 ISDN S0 interface
- 5.7 COM interface
- 5.8 Line extension of the COM interface
- 5.9 Line extension of the protocol printer for logging (Leiser)
- 5.10 Line extension of the host interface (without handshake)
- 5.11 Schauf Hallway Displays

5.1 Power supply

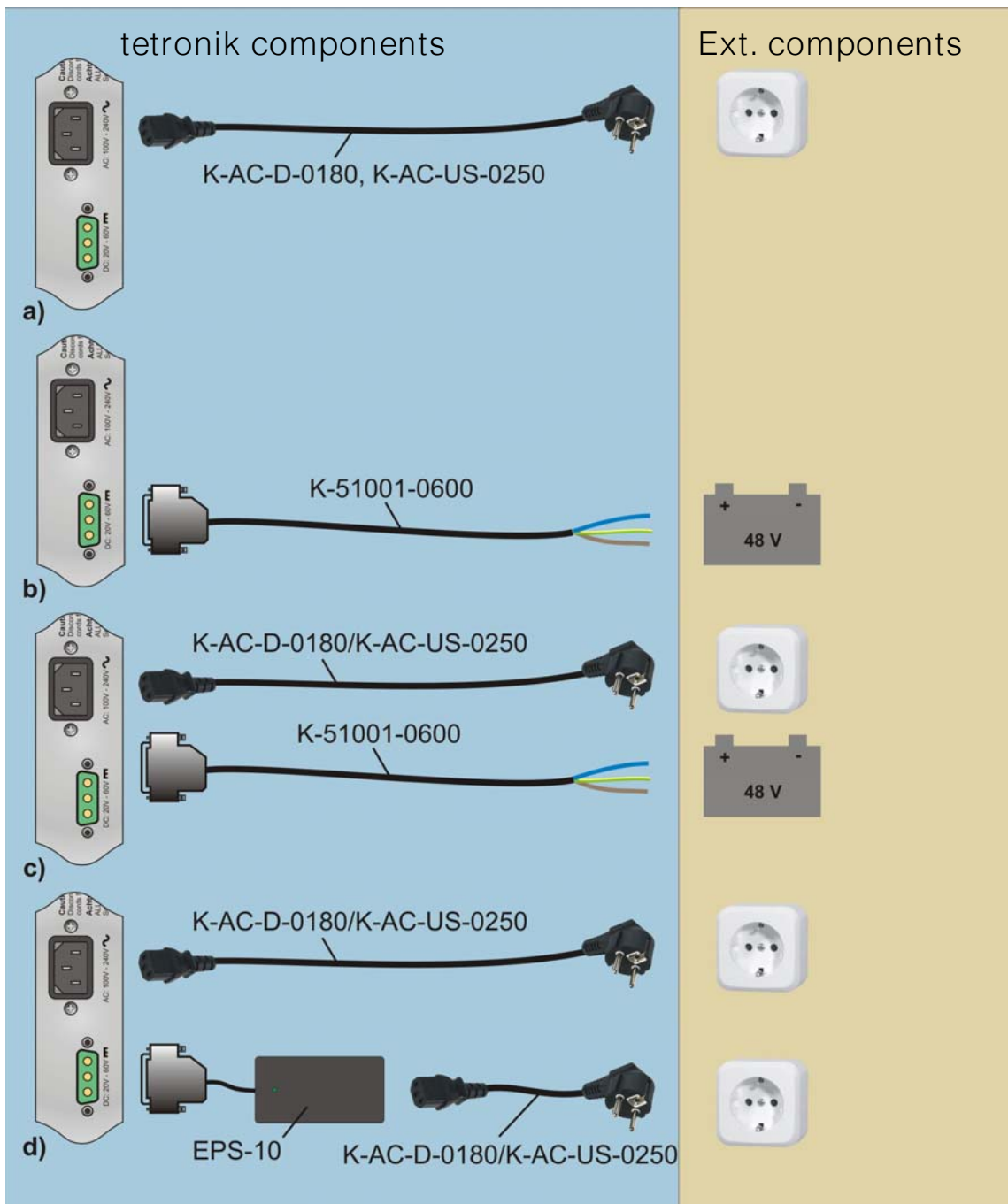


Image 5-1 Wiring plan power supply: a) only AC, b) only DC, c) AC and DC, d) AC and AC

The power supply can be via AC, DC, or AC and DC.

When using both types of power supply, OScAR 200 draws its main power from the AC power supply unit. If one of the two power supplies should fail, the system will detect the breakdown and OScAR 200 can issue a warning (e.g. SNMP).

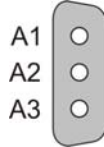
Element	Description									
K-AC-D-0180 K-AC-US-0250	AC connector cable Germany/USA									
EPS-10	DC power supply unit									
DC power supply cable	<p>Cable to connect OScAR 200 to an 48V power supply (e.g. PBX battery)</p>  <table style="margin-left: 20px;"> <tr> <td>A1:</td> <td>- DC</td> <td>blue</td> </tr> <tr> <td>A2:</td> <td>GND</td> <td>green-yellow</td> </tr> <tr> <td>A3:</td> <td>+ DC</td> <td>brown</td> </tr> </table>	A1:	- DC	blue	A2:	GND	green-yellow	A3:	+ DC	brown
A1:	- DC	blue								
A2:	GND	green-yellow								
A3:	+ DC	brown								

Table 5-1 Power supply

5.2 USB service

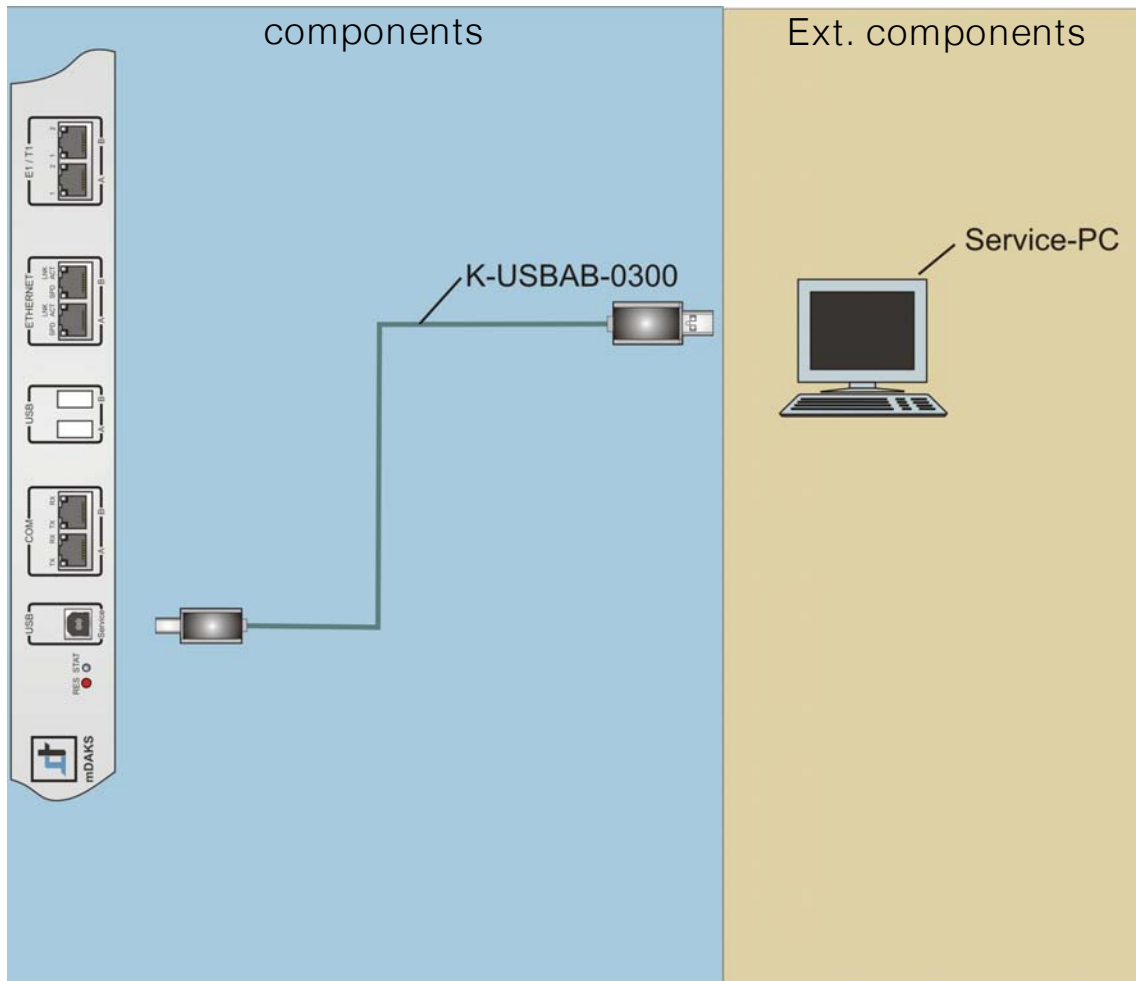


Image 5-2 USB Service wiring plan

Element	Description
K-USBAB-0300	USB cable cord
Service PC	PC with a terminal emulation program for configuration and servicing purposes

Table 5-2 USB Service wiring plan

5.3 Ethernet interface

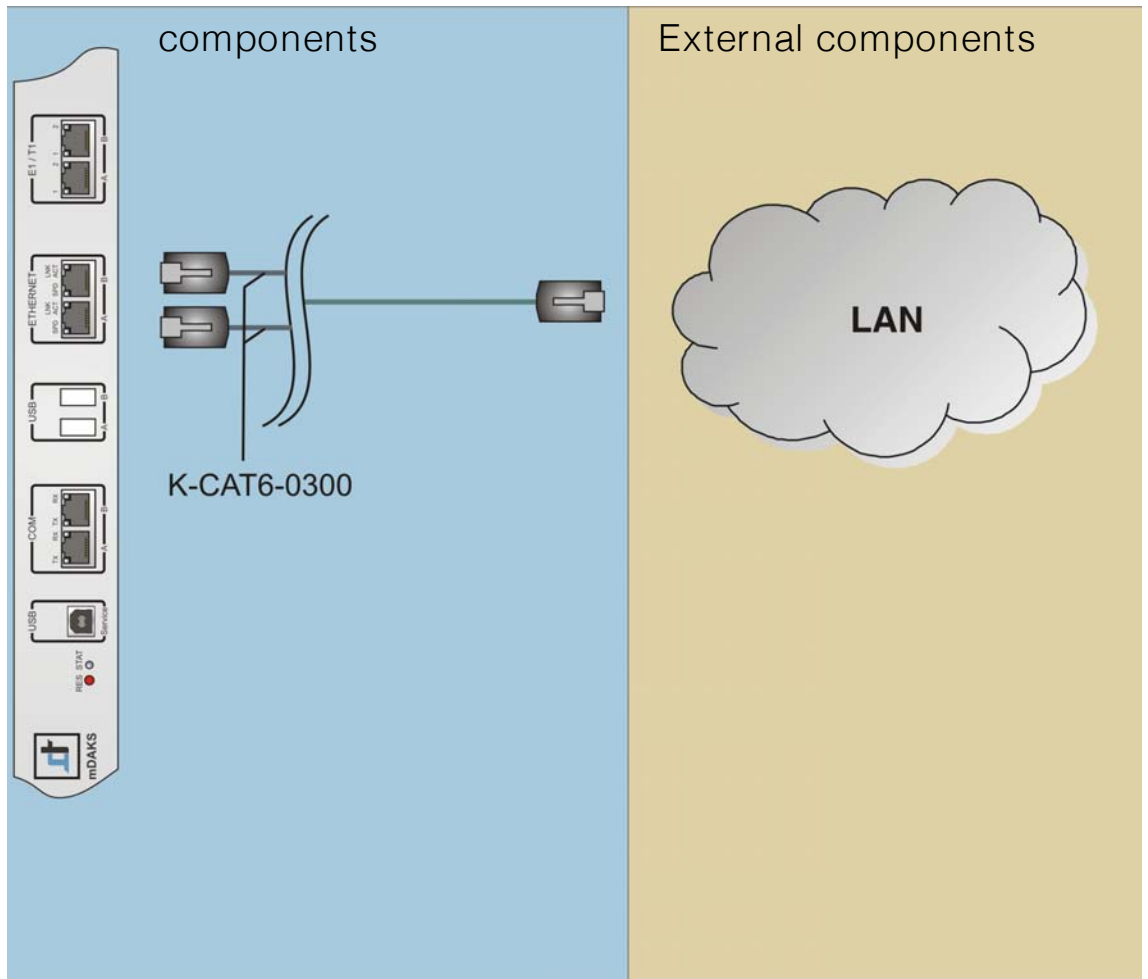


Image 5-3 Wiring plan of the Ethernet interface

Element	Description
K-CAT6-0300	Standard patch cable
LAN	Link-up of OScAR 200 to the LAN

Table 5-3 Wiring plan Ethernet interface

5.4 USB port

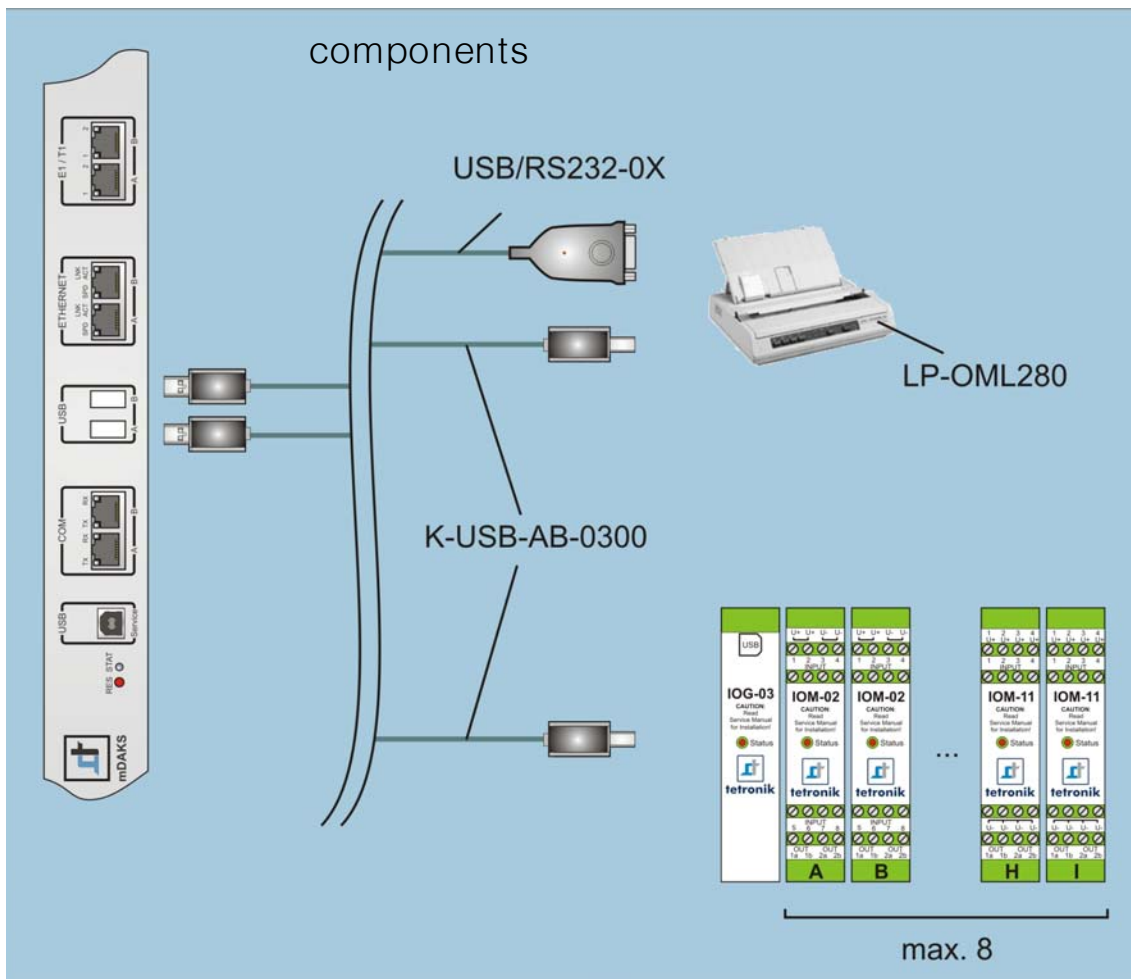


Image 5-4 Wiring plan of the USB port

Element	Description
K-USBAB-0300	USB connector cable
LP-OML280	Protocol printer for logging
IOG-03	Gateway for USB connection
IOM-02	I/O Module Standard
IOM-11	I/O Module Secure
USB/RS232-0X	Adapter to convert from USB to RS232

Table 5-4 Wiring plan of the USB port

5.5 ISDN E1/T1 interface

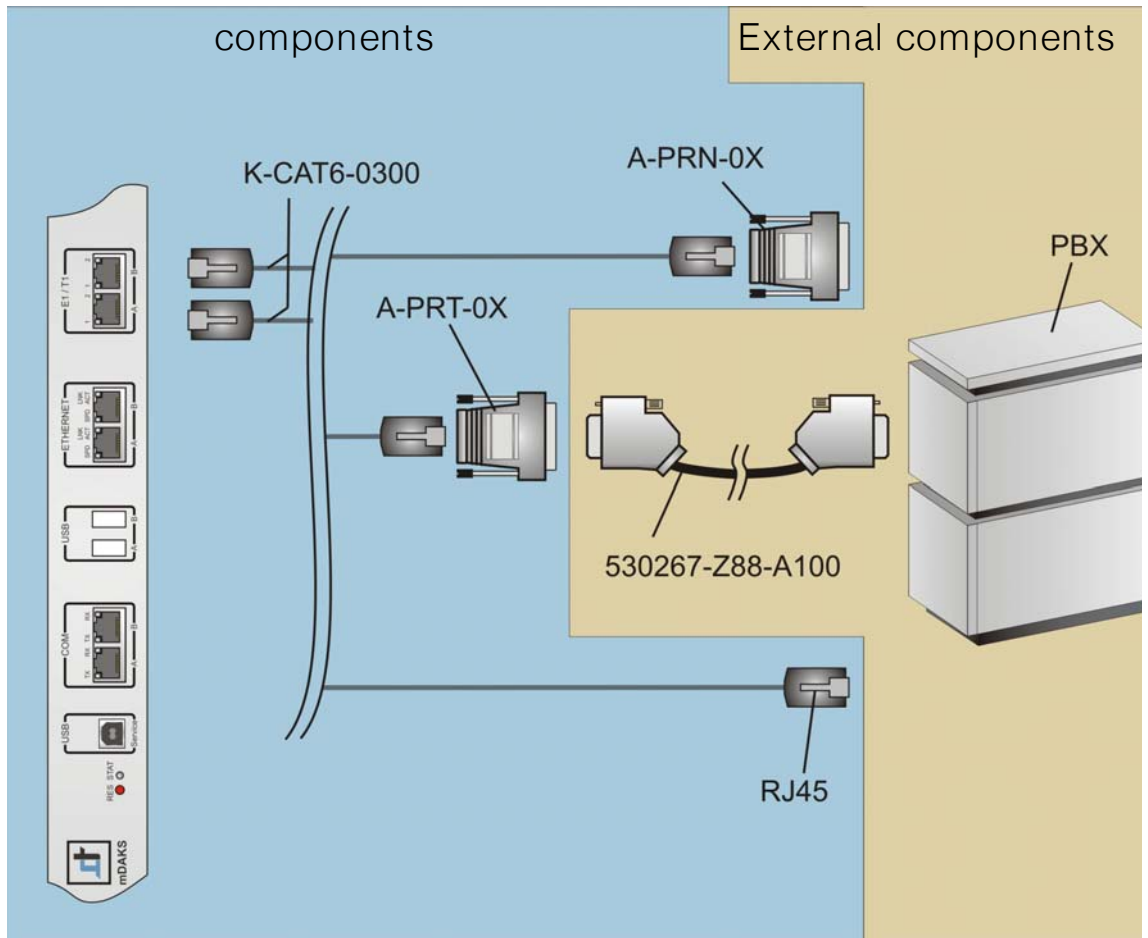


Image 5-5 Wiring plan of the ISDN-E1/T1 interface



Warning!

For ISDN connections, please use connection cables with a diameter of at least 0.4 mm (AWG26 or superior).

Element	Description
K-CAT6-0300	Standard patch cable
530267-Z88-A100	Unify S _{2M} cable 530267-Z88-A100 to network PBXes
PBX	Public exchange system
A-PRN-0X	Adapter to connect A31003S1850S101017620 directly to a Unify PBX system (OpenScape)
	<p>Pin 8: Rx+</p> <p>Pin 15: Rx-</p> <p>Pin 1: Tx+</p> <p>Pin 9: Tx-</p> <p>Pin 3: connected to Pin 10</p> <p>Pin 7: connected to Pin 14</p> <p>Pin 2, 4-6, 11-13: n. c.</p>

Table 5-5 Wiring plan of the ISDN E1/T1 interface

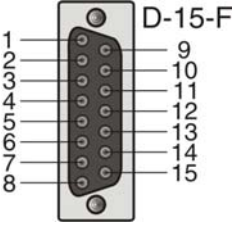
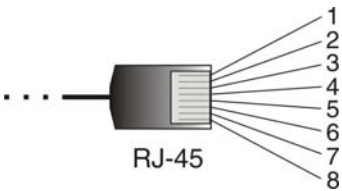
Element	Description
A-PRT-0X	<p>Adapter to connect A31003S1850S101017620 to a Unify PBX system (OpenScape), using a Unify S_{2M} cable 530267-Z88-A100</p>  <p>Pin 8: Tx+ Pin 15: Tx- Pin 1: Rx+ Pin 9: Rx- Pin 2-7, 10, 11-14: n. c.</p>
RJ45	<p>Pin assignment of the patch cable plug to connect OScAR 200 to any PBXes.</p>  <p>Pin 1: Rx+ Pin 2: Rx- Pin 4: Tx+ Pin 5: Tx- Pin 3, 6-8: n. c.</p>

Table 5-5 Wiring plan of the ISDN E1/T1 interface

5.6 ISDN S₀ interface

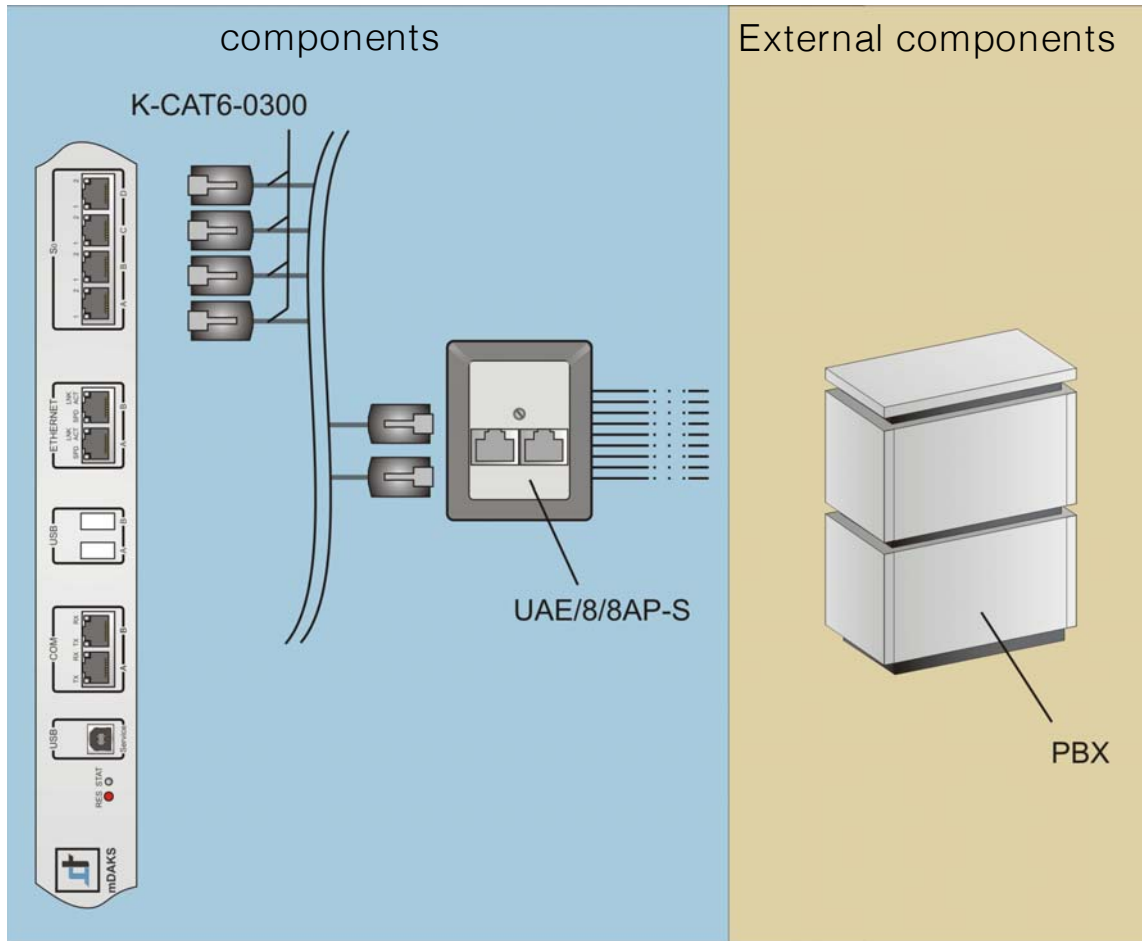


Image 5-6 Wiring plan of the ISDN S₀ interface



Warning!

For ISDN connections, please use connection cables with a diameter of at least 0.4 mm (AWG26 or superior).

Element	Description
K-CAT6-0300	Standard patch cable
PBX	PBX system
UAE/8/8/AP	Socket for S ₀ to connect OScAR 200 to a PBX system.

Pin	Description
Pin 1:	n.c.
Pin 2:	n.c.
Pin 3:	Tx+
Pin 4:	Rx-
Pin 5:	Rx+
Pin 6:	Tx-
Pin 7:	n.c.
Pin 8:	n.c.

Table 5-6 Wiring plan of the ISDN S₀ interface

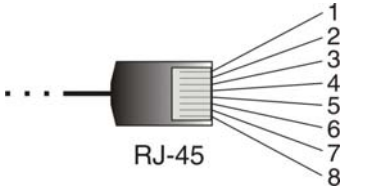
Element	Description
RJ45	<p>Pin assignment of the patch cable plug to connect OScAR 200 to any PBXes.</p>  <p>Pin 1: n.c. Pin 2: n.c. Pin 3: Tx+ Pin 4: Rx- Pin 5: Rx+ Pin 6: Tx- Pin 7: n.c. Pin 8: n.c.</p>

Table 5-6 Wiring plan of the ISDN S₀ interface

5.7 COM interface

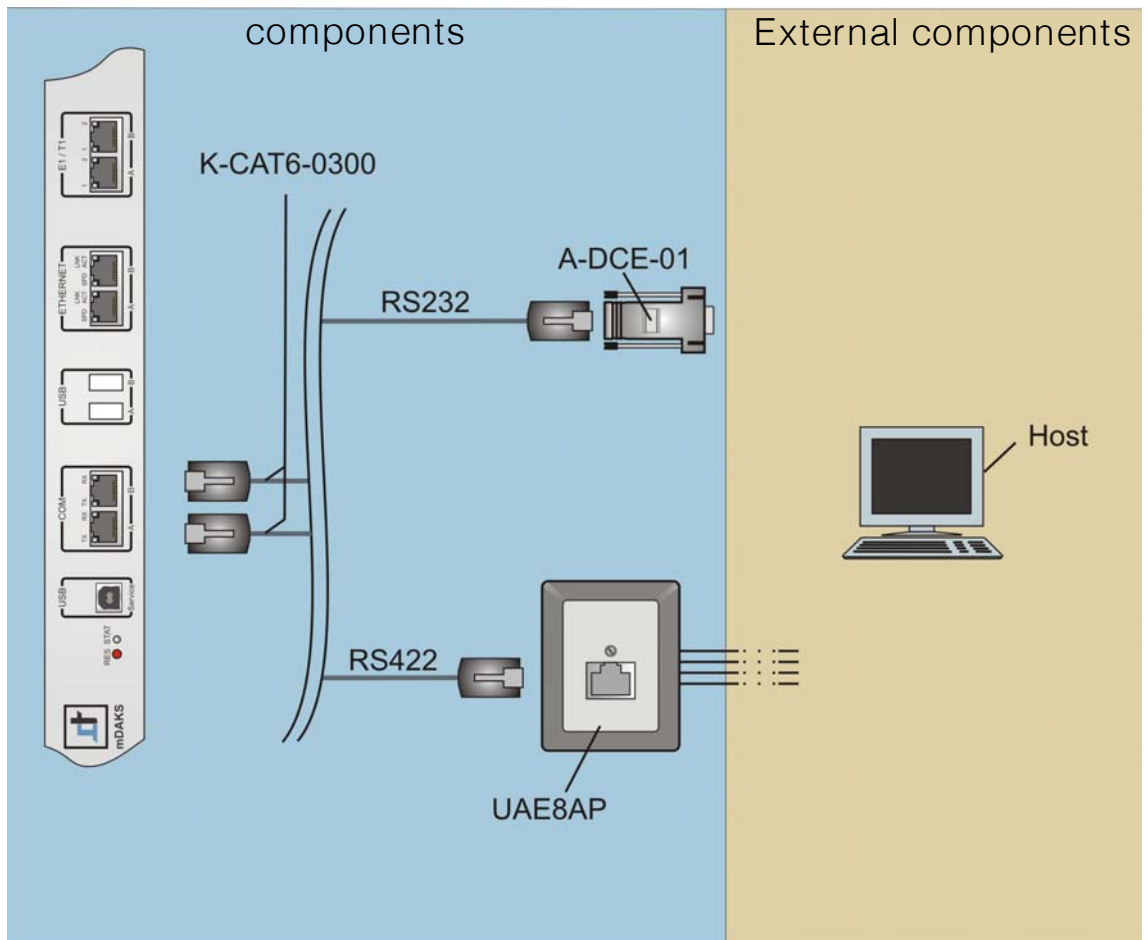


Image 5-7 Wiring plan COM interface



Warning!

For RS232 and line lengths that exceed 15 m, you need to employ a line extension of the serial connections.

- see Section 5.8 "Line extension of the COM interface"

Element	Comment
K-CAT6-0300	Standard patch cable
PC/Host	Data Terminal Equipment (DTE), e.g. a nurse call system, connected either via RS232 or via RS422
A-DCE-01	Adapter to connect OSCAR 200 to a DTE device

	D-09-F Pin 1: DCD Pin 6: DSR Pin 2: RxD Pin 7: RTS Pin 3: TxD Pin 8: CTS Pin 4: DTR Pin 9: RI Pin 5: GND
--	--

Table 5-7 Wiring plan of the COM interface

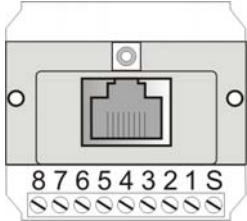
Element	Comment
UAE8AP	Socket for an RS422 interface.  <ul style="list-style-type: none"> Pin 2: Tx+/Y Pin 3: GND Pin 4: Tx-/Z Pin 5: Rx+/A Pin 7: Rx-/B Pin 1, 6, 8: n. c.

Table 5-7 Wiring plan of the COM interface

5.8 Line extension of the COM interface

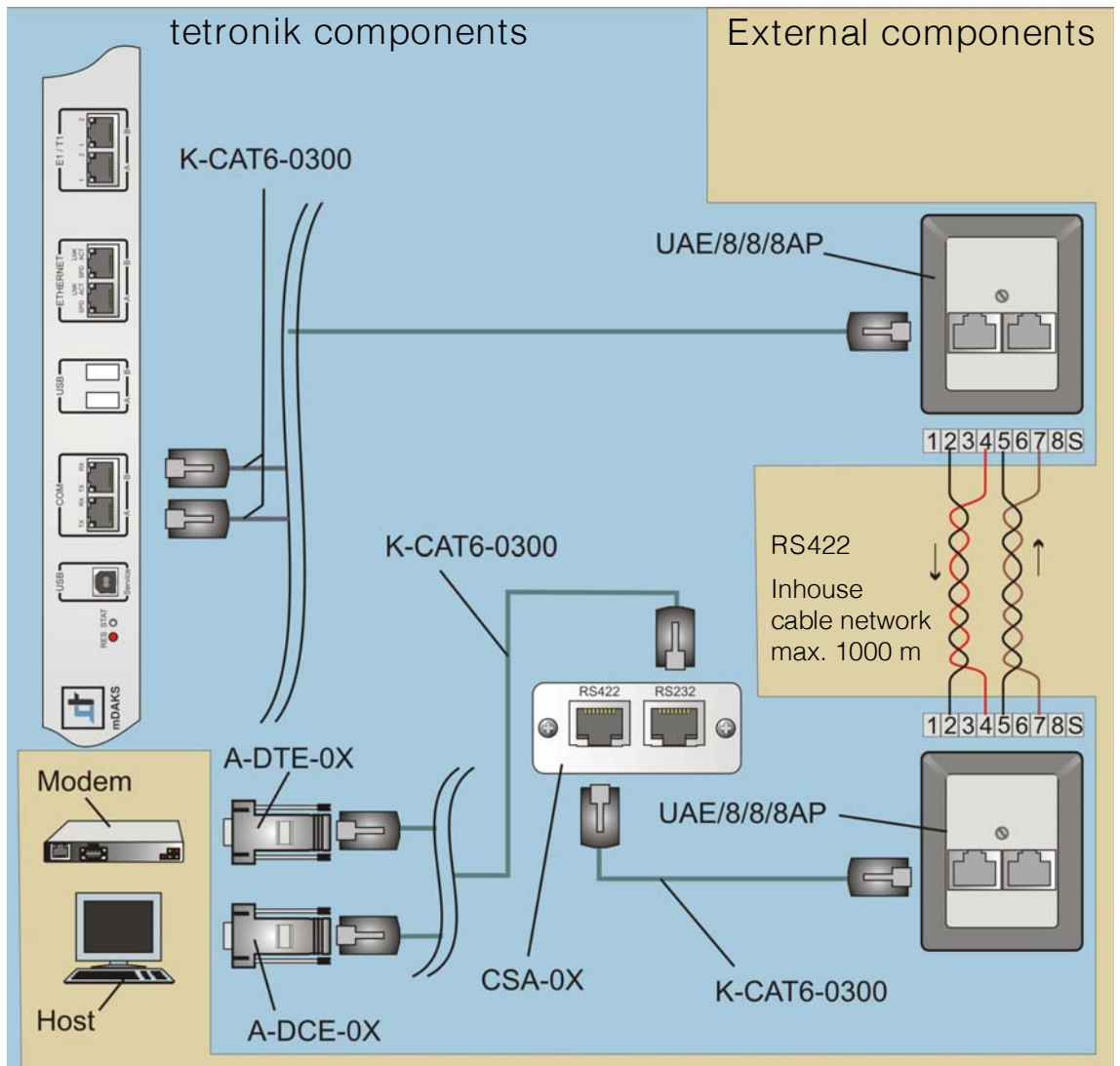


Image 5-8 Wiring plan of the COM interface line extension

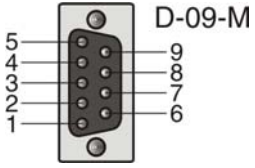
Element	Comment																				
Modem	Data Communication Equipment (DCE)/Modem, e.g. a GSM radio modem																				
A-DTE-0X	Adapter to connect OScAR 200 to a DCE device  <table border="0" style="display: inline-table; vertical-align: middle;"> <tr> <td>Pin 1:</td> <td>DCD</td> <td>Pin 6:</td> <td>DSR</td> </tr> <tr> <td>Pin 2:</td> <td>RxD</td> <td>Pin 7:</td> <td>RTS</td> </tr> <tr> <td>Pin 3:</td> <td>TxD</td> <td>Pin 8:</td> <td>CTS</td> </tr> <tr> <td>Pin 4:</td> <td>DTR</td> <td>Pin 9:</td> <td>n. c.</td> </tr> <tr> <td>Pin 5:</td> <td>GND</td> <td></td> <td></td> </tr> </table>	Pin 1:	DCD	Pin 6:	DSR	Pin 2:	RxD	Pin 7:	RTS	Pin 3:	TxD	Pin 8:	CTS	Pin 4:	DTR	Pin 9:	n. c.	Pin 5:	GND		
Pin 1:	DCD	Pin 6:	DSR																		
Pin 2:	RxD	Pin 7:	RTS																		
Pin 3:	TxD	Pin 8:	CTS																		
Pin 4:	DTR	Pin 9:	n. c.																		
Pin 5:	GND																				
PC/Host	Data Terminal Equipment (DTE) e.g. a call system																				

Table 5-8 Wiring plan of the COM interface line extension

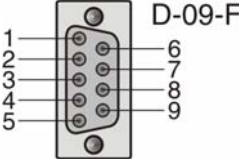
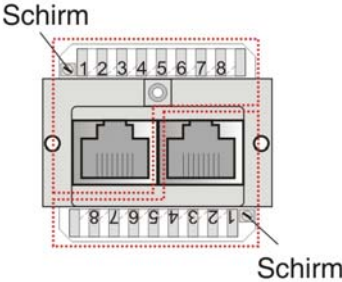
Element	Comment																				
A-DCE-0X	Adapter to connect OScAR 200 to a DTE device  <table border="0" data-bbox="970 315 1362 472"> <tr> <td>Pin 1:</td> <td>DCD</td> <td>Pin 6:</td> <td>DSR</td> </tr> <tr> <td>Pin 2:</td> <td>RxD</td> <td>Pin 7:</td> <td>RTS</td> </tr> <tr> <td>Pin 3:</td> <td>TxD</td> <td>Pin 8:</td> <td>CTS</td> </tr> <tr> <td>Pin 4:</td> <td>DTR</td> <td>Pin 9:</td> <td>n. c.</td> </tr> <tr> <td>Pin 5:</td> <td>GND</td> <td></td> <td></td> </tr> </table>	Pin 1:	DCD	Pin 6:	DSR	Pin 2:	RxD	Pin 7:	RTS	Pin 3:	TxD	Pin 8:	CTS	Pin 4:	DTR	Pin 9:	n. c.	Pin 5:	GND		
Pin 1:	DCD	Pin 6:	DSR																		
Pin 2:	RxD	Pin 7:	RTS																		
Pin 3:	TxD	Pin 8:	CTS																		
Pin 4:	DTR	Pin 9:	n. c.																		
Pin 5:	GND																				
K-CAT6-0300	Standard patch cable																				
UAE/8/8/8AP	Socket for an RS422 interface.  <table border="0" data-bbox="970 595 1161 786"> <tr> <td>Pin 2:</td> <td>Tx+/Y</td> </tr> <tr> <td>Pin 3:</td> <td>GND</td> </tr> <tr> <td>Pin 4:</td> <td>Tx-/Z</td> </tr> <tr> <td>Pin 5:</td> <td>Rx+/A</td> </tr> <tr> <td>Pin 7:</td> <td>Rx-/B</td> </tr> <tr> <td>Pin 1, 6, 8:</td> <td>n. c.</td> </tr> </table>	Pin 2:	Tx+/Y	Pin 3:	GND	Pin 4:	Tx-/Z	Pin 5:	Rx+/A	Pin 7:	Rx-/B	Pin 1, 6, 8:	n. c.								
Pin 2:	Tx+/Y																				
Pin 3:	GND																				
Pin 4:	Tx-/Z																				
Pin 5:	Rx+/A																				
Pin 7:	Rx-/B																				
Pin 1, 6, 8:	n. c.																				
CSA-0X	Conversion from RS422 to RS232																				

Table 5-8 Wiring plan of the COM interface line extension

5.9 Line extension of the protocol printer for logging (Leiser)

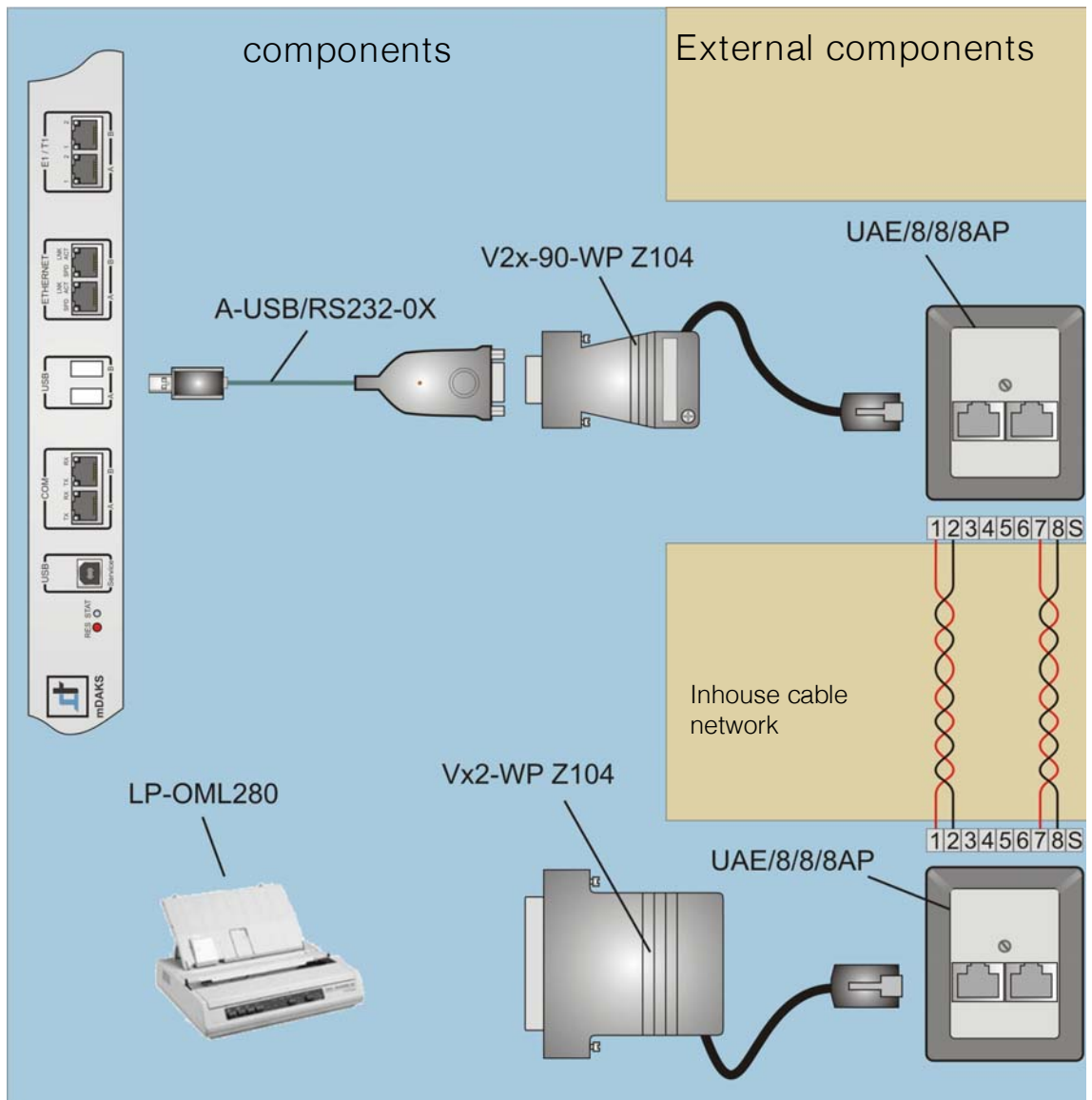


Image 5-9 Wiring plan: Line extension of the protocol printer for logging (Leiser)

Element	Comment
USB/RS232-0X	Adapter to convert from USB to RS232
Leiser Vx2-90-WPZ104	Transmission kit for OScAR 200 to printer
Leiser Vx2-WPZ104	Transmission kit for printer
UAE/8/8/8AP	Female half connector to extend the RS422 interface
LP-OML280-2	Protocol printer for logging
OML280S	RS232 interface module
LP-OML280-2S	LP-OML280-2 with connected RS232 interface module

Table 5-9 Wiring plan: Line extension of the protocol printer for logging (Leiser)

5.10 Line extension of the host interface (without handshake)

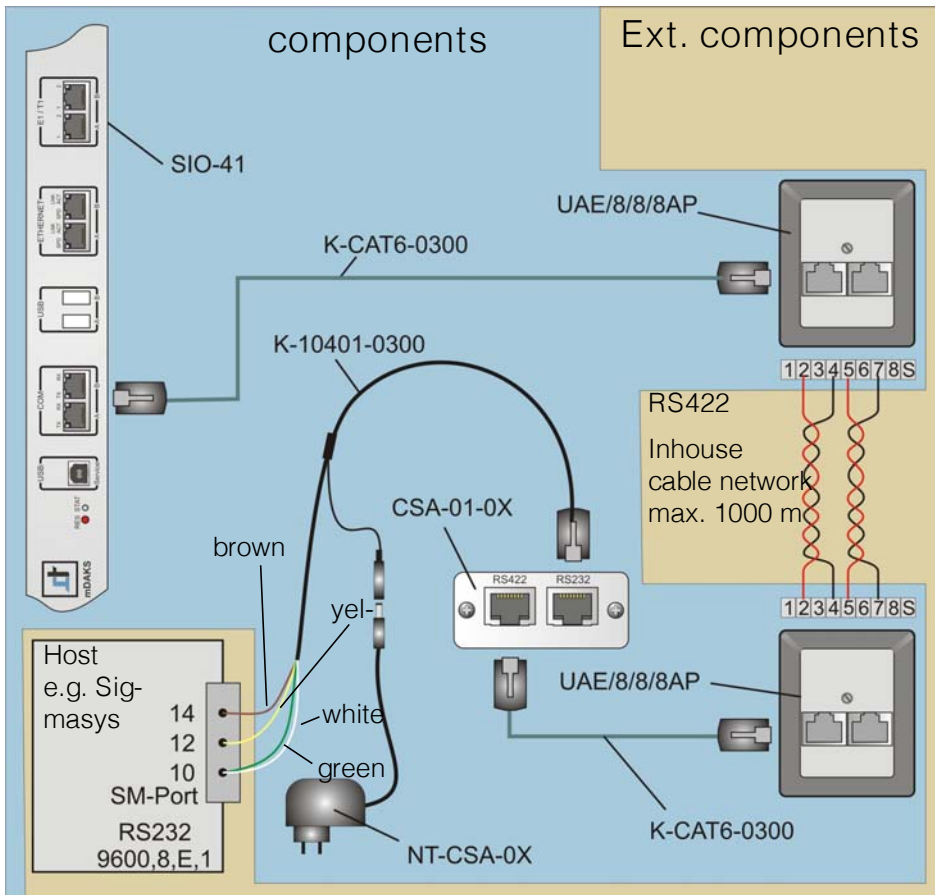


Image 5-10 Wiring plan: Line extension of the Host interface (without handshake)

Element	Comment
K-CAT6-0300	Standard patch cable
UAE/8/8/8AP	Female half connector for the line extension.
CSA-01-0X	Conversion from RS422 to RS232
K-10401-0300	RS-232 data cable cord: Adapter to connect the CSA converter to the electric power supply and the Host (e.g. Sigmasys) <ul style="list-style-type: none"> • brown: TxD • yellow: RxD • white: GND • green: GND
NT-CSA-0X	Power supply of the CSA converter <ul style="list-style-type: none"> • Input voltage: 230 V • Output voltage: 9 V • max. output current: 250 mA
Host	e.g. Sigmasys (fire alarm system)

Table 5-10 Wiring plan: Line extension of the Host interface (Sigmasys)

5.11 Schauf Hallway Displays

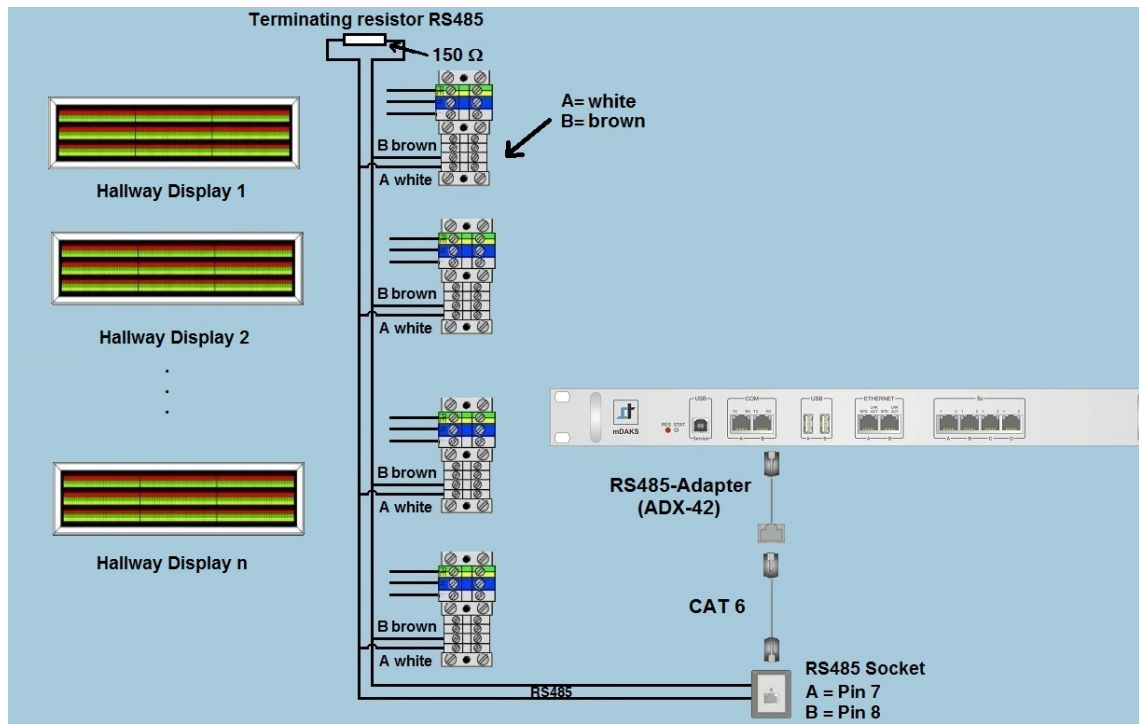


Image 5-11 Wiring plan - Schauf hallway display units

Element	Anmerkungen
	RS485 Bus length max.500 m
	Spur/stub lines to the hallway display units, each max.5 m
	Twisted pair cables must be shielded; the shield must be carried along.
	The OScAR server must be installed at one end of the RS485. The other end of the Bus must be terminated with a 150 Ω resistor.

Table 5-11 Wiring plan - Schauf hallway display units

6 PBX Systems and Soft Switches

This chapter covers in brief the coupling of OScAR 200 to the PBX network or the convergent voice/data networks and to the trunk connections. It also refers to the external configuration instructions for the respective interface(s).

Overview:

The coupling between OScAR 200 and the PBX network or the convergent voice/data network is carried out application-dependent with up to 30/60 channels:

- via ISDN with four ISDN-S0 digital trunks or via one/two S2M/E1 or T1 digital trunk(s), or
- via VoIP with LAN interface (10/100BASE-T) via VoIP trunking, S0 trunking, S2M/E1-T1 trunking.

The coupling to the PBX system or to the PBX network is carried out via trunk connection with a code and with direct inward dialing (DDI), enabling OScAR 200 to be seen, from the network's side, like an additional network node, i.e. like a subsystem with its own numbering plan.

This is therefore NOT a CSTA-coupling (such as e.g. ACL or CAP for Unify PBX systems).



Note:

OScAR 200 operates maximally with 30 channels.



Note:

Please be aware that the configuration of the interface(s) between Service Manual and the various PBX systems or soft switches is not part of this document.

For documentation of the configuration of the PBX interfaces:

- either on the Installation CD under "Documentation"
Caution! This information may have already become obsolete!



Warning!

To access the Extranet, you must be a service technician trained on OScAR and registered with tetronik GmbH (access data already be available for FTP-download can be used for this area also).

