



A MITEL  
PRODUCT  
GUIDE

# MiContact Center Enterprise

Virtual Contact Center Configuration - Description

**Release 9.7**

Document Version 1.0

November 2023

## Notices

The information contained in this document is believed to be accurate in all respects but is not warranted by **Mitel Networks™ Corporation (MITEL®)**.

The information is subject to change without notice and should not be construed in any way as a commitment by Mitel or any of its affiliates or subsidiaries. Mitel and its affiliates and subsidiaries assume no responsibility for any errors or omissions in this document. Revisions of this document or new editions of it may be issued to incorporate such changes. No part of this document can be reproduced or transmitted in any form or by any means - electronic or mechanical - for any purpose without written permission from Mitel Networks Corporation.

## Trademarks

The trademarks, service marks, logos and graphics (collectively "Trademarks") appearing on Mitel's Internet sites or in its publications are registered and unregistered trademarks of Mitel Networks Corporation (MNC) or its subsidiaries (collectively "Mitel") or others. Use of the Trademarks is prohibited without the express consent from Mitel. Please contact our legal department at [legal@mitel.com](mailto:legal@mitel.com) for additional information. For a list of the worldwide Mitel Networks Corporation registered trademarks, please refer to the website: <http://www.mitel.com/trademarks>.

®,™ Trademark of Mitel Networks Corporation

© Copyright 2023, Mitel Networks Corporation All rights reserved

## INTRODUCTION

This document consists of an overview of the MiCC Enterprise system in different network configurations and descriptions of how they are configured.

## OVERVIEW

MiCC Enterprise can be configured to support virtual contact centers at multiple sites and each site can be configured to use one or more Telephony Application Server (TAS) or Open Application Server (OAS).



Note: In this release, only MX-ONE call managers are supported in a VCC network. TAS and OAS servers cannot be mixed in the VCC network. I.e., if TAS is used then all sites in the network must use one or more TAS servers.

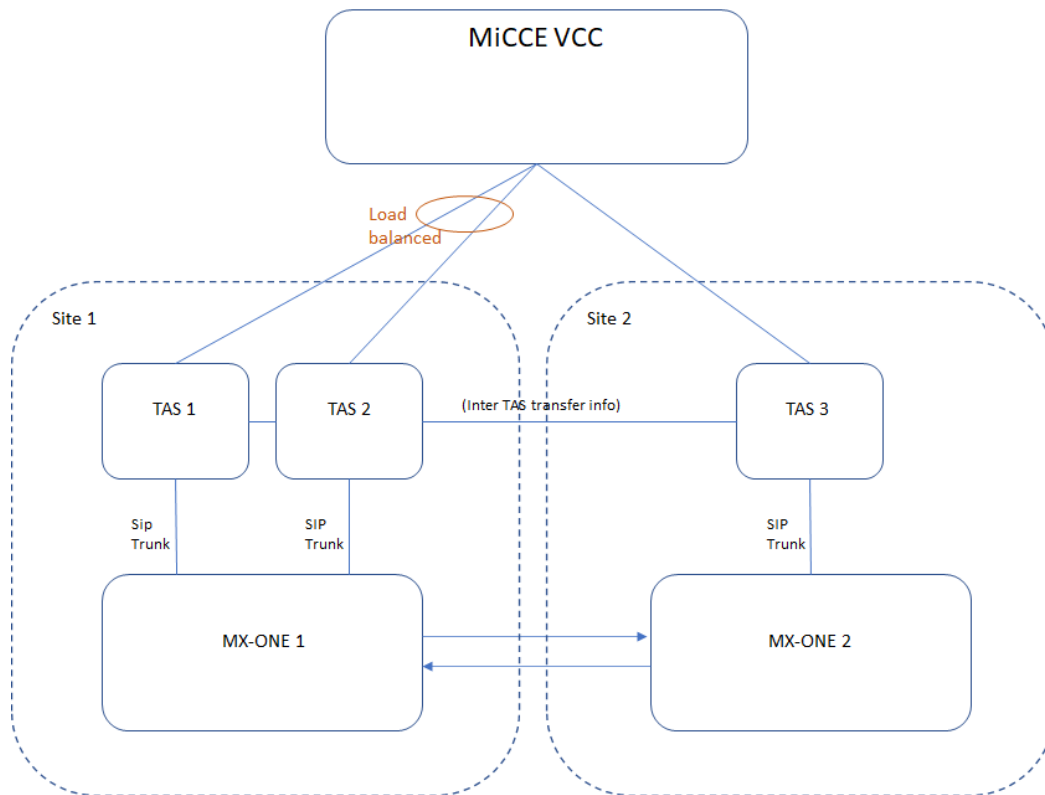
## VIRTUAL CONTACT CENTER WITH TAS

### SITES

MiCC Enterprise can use up to 20 TAS servers, which means that a total 20 VCC sites can be configured assuming each site is configured with one TAS server each.

### MULTIPLE TAS SERVERS

One site can be configured to use more than one TAS server, see Figure 1 below where Site 1 is configured with 2 TAS servers. Up to six TAS servers can be configured per site. This could be needed for capacity reasons or for redundancy. MiCC Enterprise can be configured to use up to 20 TAS servers combined from all sites.



**Figure 1: VCC with Multiple TAS servers**

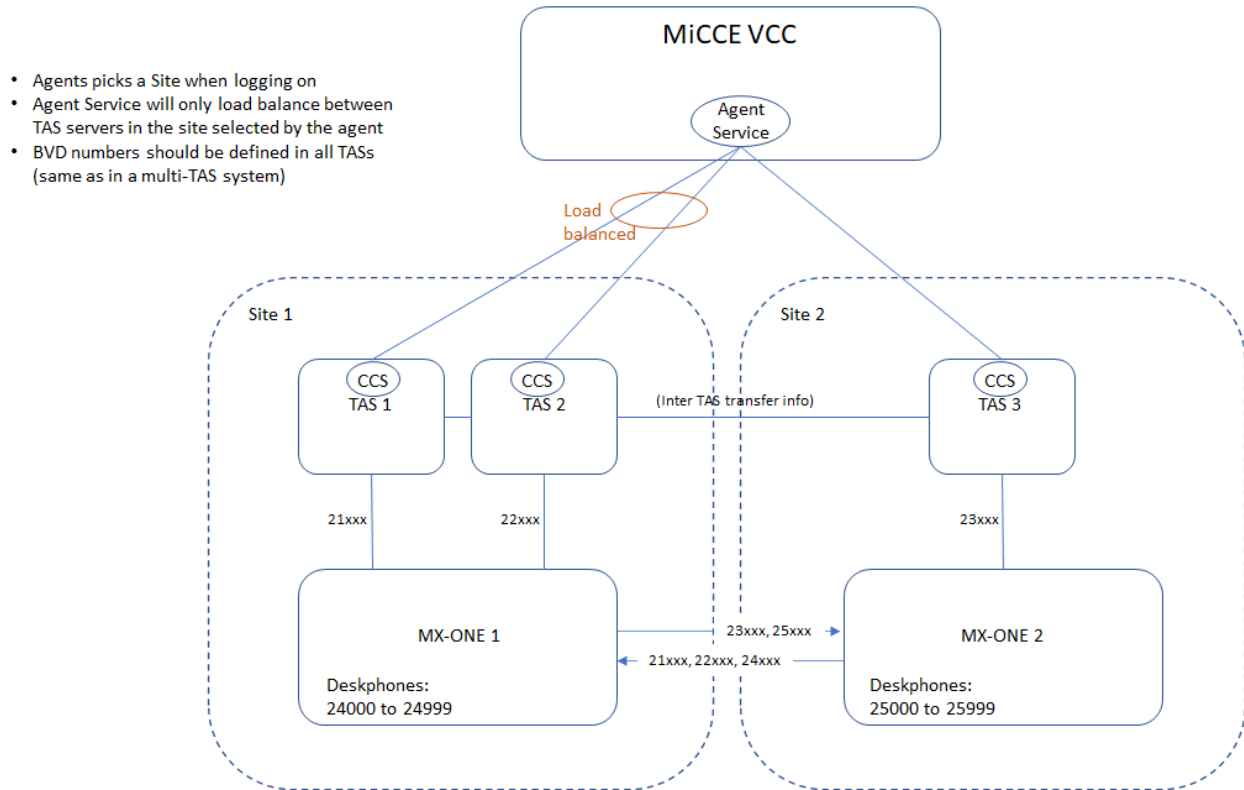


Note: Each TAS server must be configured to use a unique set of Call IDs. This is configured in the TAS Config utility.

## NUMBERING PLANS

VCC built on TAS supports MX-ONE networks configured with Closed (Coordinated) Numbering plan. This means that each MX-ONE registered extension in the network is called to by its extension number, without any prefixing, no matter from which other node in the network the call originates from. This also means that the trunk access code to the TAS server in the network must be able to be reached in the same way (un-prefixed) from any node in the network.

Figure 2 below shows a simple VCC consisting of 2 sites (MX-ONE nodes) and 3 TAS servers. Two TAS server are connected to Site 1.



**Figure 2: Example of TAS based VCC**

## TAS CONFIGURATION

TAS in a VCC is configured in the same way as it is configured in a multi-TAS system. Other TAS servers in the network shall be configured as TAS Peers and each TAS also needs to be configured with a unique block of Call IDs using TAS config and have its own Inter TAS transfer number configured.

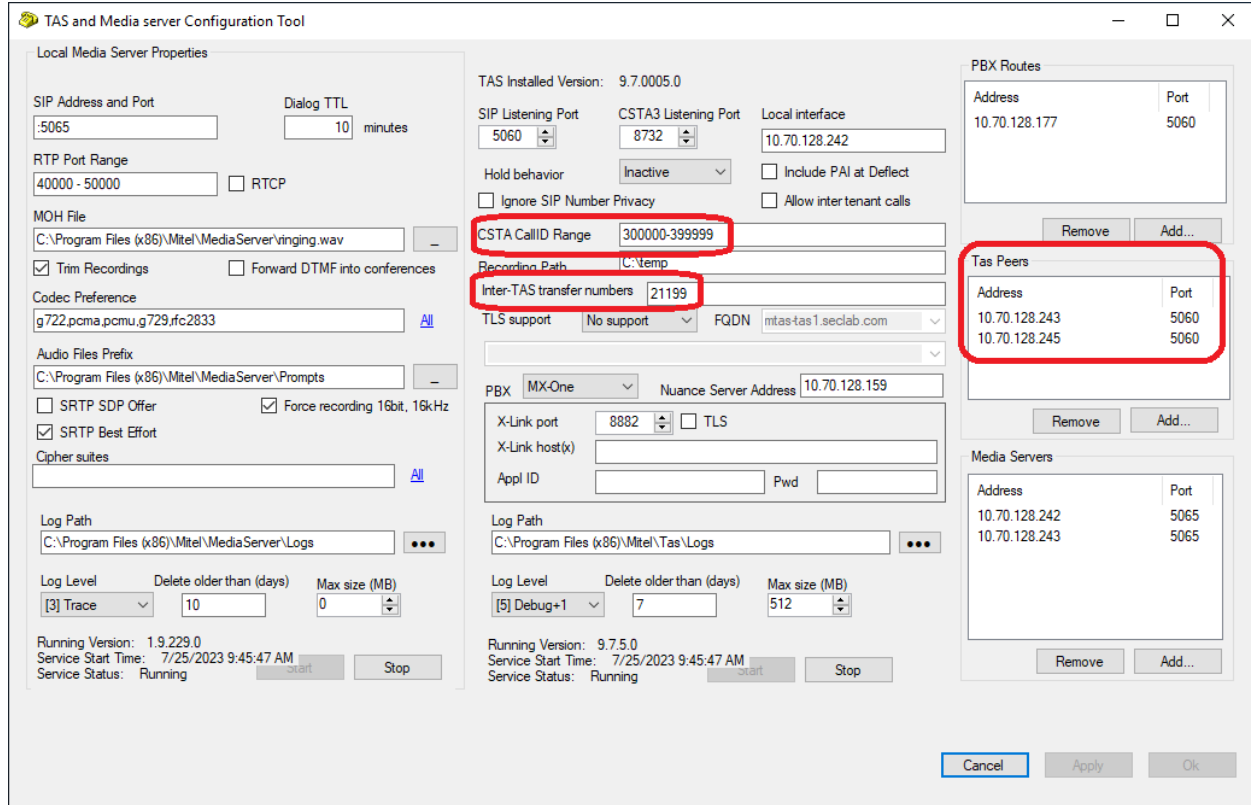


Figure 3: Example of TAS configuration

## MICC ENTERPRISE CONFIGURATION

A Site needs to be created in the MiCC Enterprise System Properties for each MX-ONE node that will be part of the VCC network. Since only closed (coordinated) numbering plan is used for VCCs based on TAS, there is no need to setup Access Codes information for the Sites.

Using the example shown in Figure 2 above, the site settings in Configuration Manager would be as shown in Figure 4 below. Note that Site 1 has two TAS servers configured.

The screenshot shows the 'Contact Center System Properties - Advanced' dialog box with the 'Site Configuration' tab selected. Under the 'Site1' sub-tab, the 'Site Details' section is active. The 'Site Name' is 'Site1'. The 'Call Manager Servers' list contains 'mtas-tas1' (selected) and 'mtas-tas2'. The 'Call Manager Server Details' for 'mtas-tas1' are: Name: mtas-tas1, Server: mtas-tas1.secd, Port: 8732, User Name: (empty), Password: (empty), Call Control Server: 10.70.128.242. The 'SIP Settings' are: Proxy Server: 10.70.128.242, Port: 5060, Secondary Proxy: (empty), Port: 5060, Outbound Proxy: (empty), Port: 5060. The 'Security' section has 'Voice Encryption' set to 'Disabled'. The 'DTMF Type' is set to 'SIP INFO'. The 'Access Codes' section has 'Conference' and 'Transfer' fields empty. Buttons for 'New Site', 'Delete Site', 'Access Codes...', 'New Server', and 'Delete Server' are visible. The bottom of the dialog has 'OK', 'Cancel', and 'Help' buttons.

The screenshot shows the 'Contact Center System Properties - Advanced' dialog box with the 'Site Configuration' tab selected. Under the 'Site2' sub-tab, the 'Site Details' section is active. The 'Site Name' is 'Site2'. The 'Call Manager Servers' list contains 'mtas-tas3' (selected). The 'Call Manager Server Details' for 'mtas-tas3' are: Name: mtas-tas3, Server: mtas-tas3.secd, Port: 8732, User Name: (empty), Password: (empty), Call Control Server: 10.70.128.245. The 'SIP Settings' are: Proxy Server: 10.70.128.245, Port: 5060, Secondary Proxy: (empty), Port: 5060, Outbound Proxy: (empty), Port: 5060. The 'Security' section has 'Voice Encryption' set to 'Disabled'. The 'DTMF Type' is set to 'SIP INFO'. The 'Access Codes' section has 'Conference' and 'Transfer' fields empty. Buttons for 'New Site', 'Delete Site', 'Access Codes...', 'New Server', and 'Delete Server' are visible. The bottom of the dialog has 'OK', 'Cancel', and 'Help' buttons.

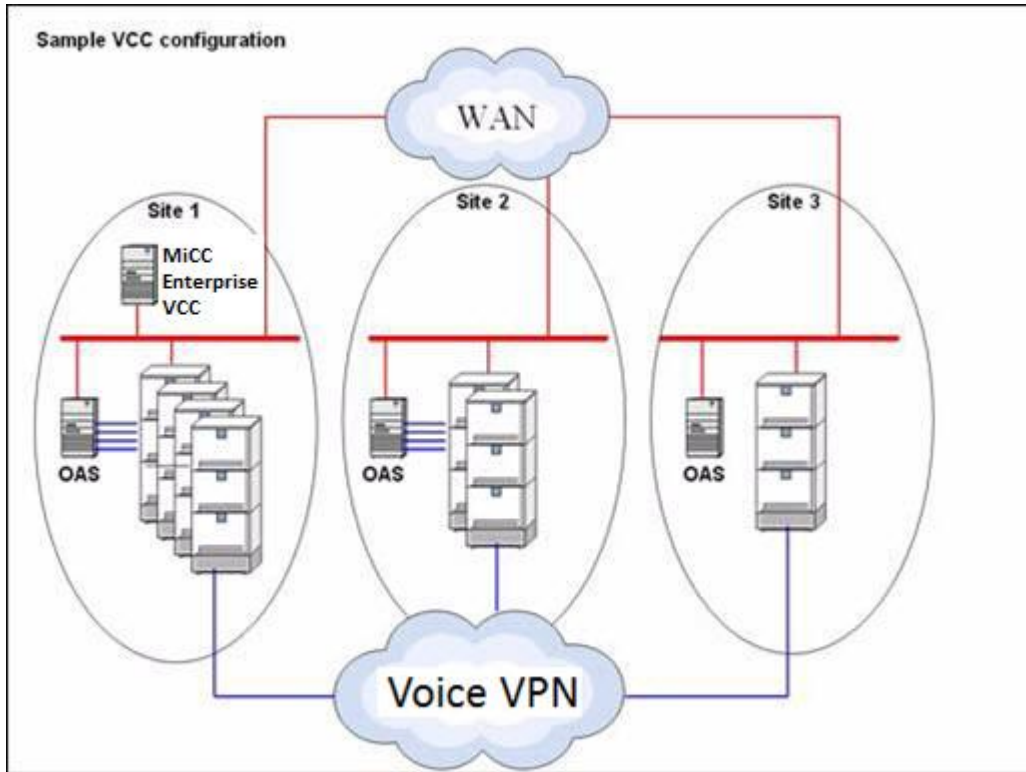
**Figure 4: Site Configuration**

As for any regular multi-TAS configuration, BVDs, Languages and Play Message Lists must be defined in the same way in all TAS servers. That means that Language IDs must be the same in the Call Manager Resource settings and the Play Messages must be the same across the different TAS servers.

# VIRTUAL CONTACT CENTER WITH OAS


## SITES

Up to 20 sites (MX-ONE nodes) can be configured in MiCC Enterprise with virtual contact center support. Each site is a MX-ONE Telephony System node with at least one OAS server. MiCC Enterprise can use up to 20 OAS servers, which means that a total number of 20 Virtual Contact Centers can be configured.



**Figure 5: Sample VCC Configuration**

In the sample above, there are three sites. The MiCC Enterprise server is located at Site 1. Each site has an OAS server. The OAS servers at Site 2 and 3 are connected to the MiCC Enterprise server at site 1 through a Wide Area Network (WAN). The three MX-ONE systems are connected in a Virtual Private Network (VPN) via ISDN tie-lines, IP Networking or SIP trunks

-  Note: Each OAS server must have a unique node ID defined when multiple OAS servers are used with MiCC Enterprise. Each OAS Server node id in the entire virtual contact center, not just the site, must be unique. The node ID can be modified in the OAS configuration tool in the NRM section.

Configuration Manager can be used to configure site information. See Figure 6 below for the sample VCC configuration for the VCC shown in Figure 5 above.

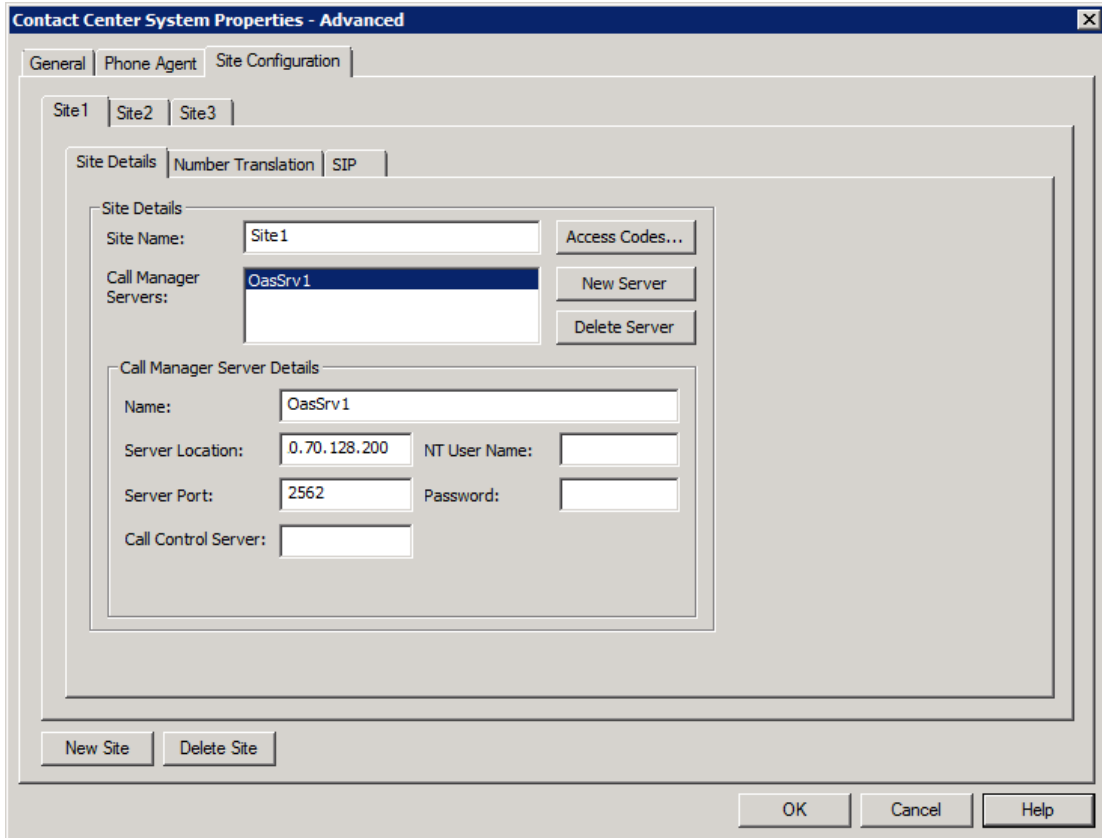


Figure 6: Screen shot of Site Configuration screen in CM

## MULTIPLE OAS SERVERS

One site can be configured to use more than one OAS server, see Figure 7 below. Up to six OAS servers can be configured per site. This could be needed for capacity reasons or for redundancy. MiCC Enterprise can be configured to use up to 20 OAS servers.



Note: Each OAS server must have a unique node id defined when multiple OAS servers are used with MiCC Enterprise. Each OAS node id in the entire virtual contact center, not just the site, must be unique. The node id can be modified in the OAS configuration tool in the NRM section.

See Figure 7 below for an example of configuration of a multiple OAS servers.

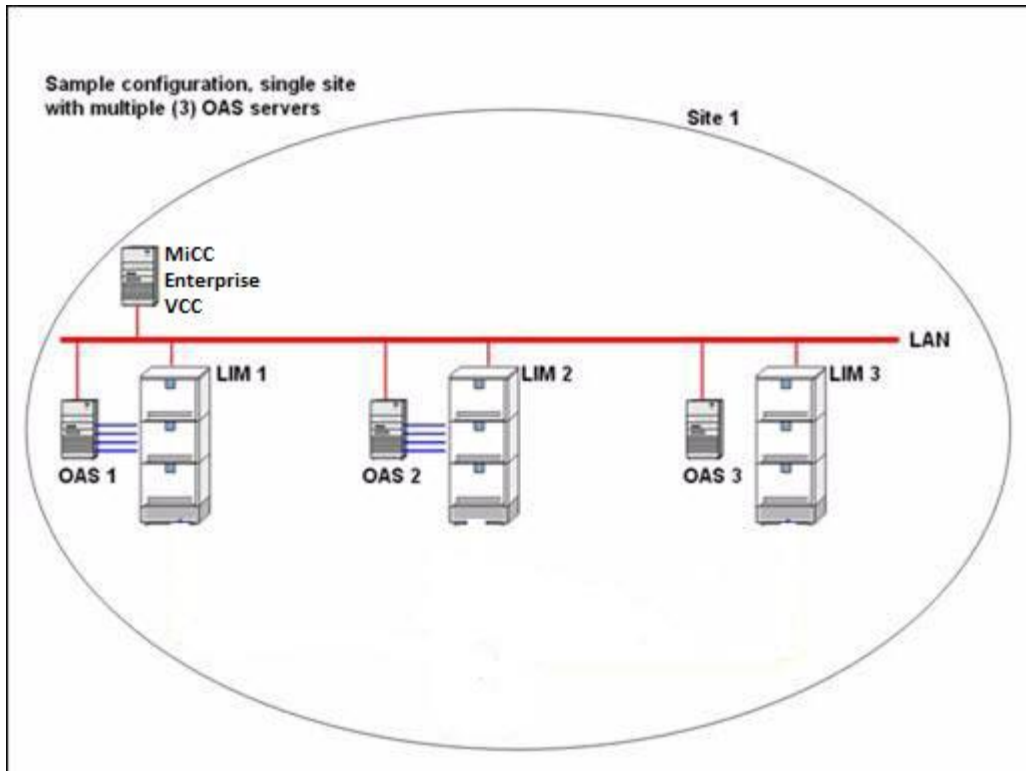
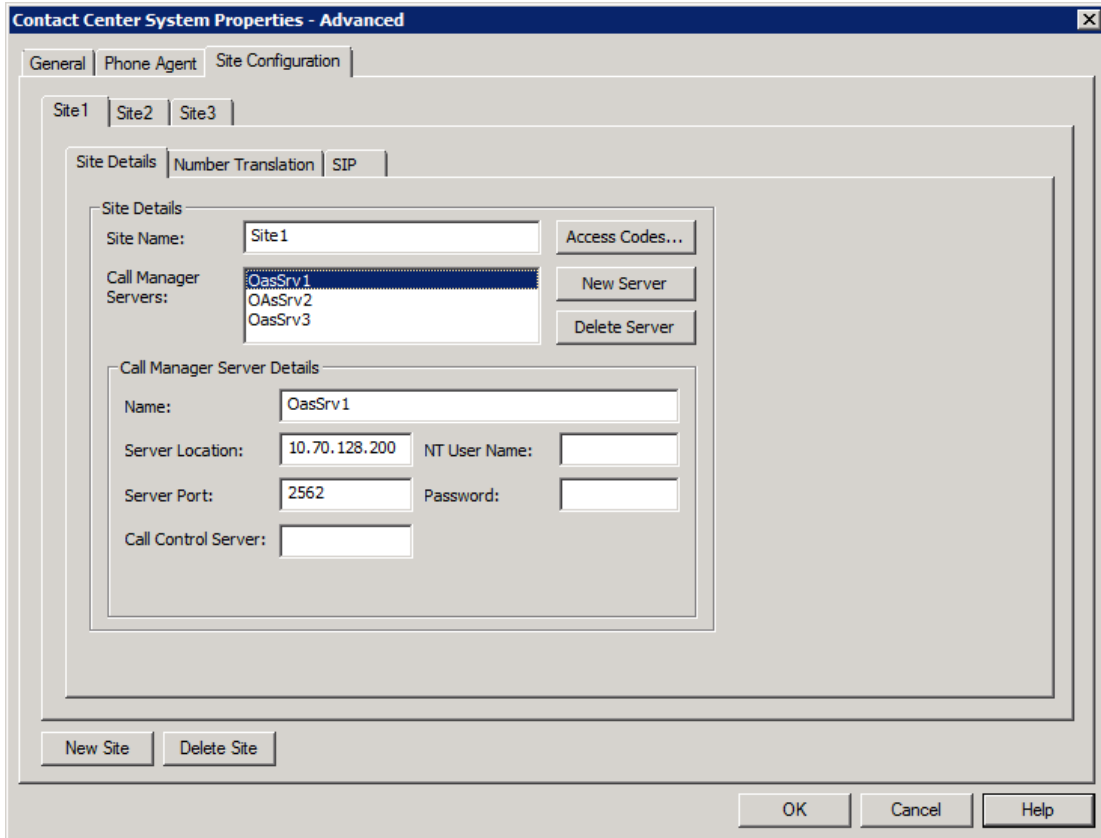


Figure 7: Multiple OAS Servers



**Figure 8: Site Details in Configuration Manager**

## NUMBERING PLANS

Since the MX-ONE call manager in a VCC network do not provide a network unique call identifier for calls between nodes, OAS servers and MiCC Enterprise are relying on that the correct number information is received from the MX-ONE in the CSTA events. To ensure this, great care has to be taken when configuring the private network. As a general rule, you have to make sure the calling number presented on the telephone display of the called party is the number that the called party can use to call back to the calling party, and vice versa.



Note: For more information on configuration of different numbering plans, refer to the MX-ONE documentation.

### Different numbering plans

MiCC Enterprise VCC supports different types of numbering plans when OAS is used.

The simplest one to configure is a Closed Numbering Plan. Other names for this are Coordinated Numbering Plan or Fixed Length Numbering Scheme. A closed numbering plan is used in a private network where there is no conflict between the first 1, 2 or 3 digits in the directory number series. Any

extension in the network is reached by dialing the directory number of the extension, irrespective of in which site the calling party is situated.

Another type of numbering plan is Open Numbering Plan, also called Uniform Numbering Plan, Location Code Based Numbering Plan or Variable Length Numbering Scheme. An open numbering plan is where each location (site) in the private network needs a unique identifier, a location code, since different sites in the network can have extensions with identical directory numbers.

MiCC Enterprise also supports a mixture of these types, Mixed Numbering Plan. In these types of networks, some sites use a closed numbering plan for calling between these sites, and other sites need a location code to be reached.

### *Closed Numbering Plan*

In the example shown in Figure 9 below, extension 1000 in Site 1 is reached in the same way, by dialing 1000, from any site in the network. In Site 2 and 3, the Route access code 1 is assigned to the Route connected to site 1. This is done by MX-ONE Telephony switch commands NANSI and RODDI.

Example:

```
number_initiate -numbertype ed -number 1  
RODDI:ROU=x, DEST=1, SRT=1, ADC=xxx;
```

No Access Code configuration is needed in the MiCC Enterprise Setup Utility for a VCC using Closed Numbering Plan.

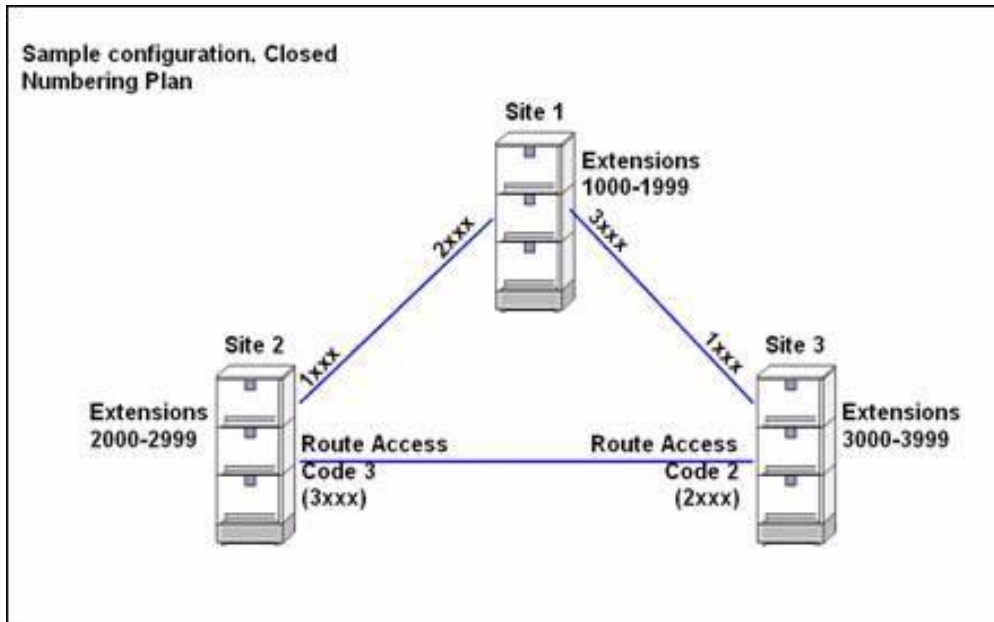


Figure 9: Closed numbering plan

### Open Numbering Plan

In the example in Figure 10 below, each Site in the network is reached by dialing a location code (access code). This access code is defined in each node as its Own Exchange Number. To reach extension 5000 in Site 2 from Site 1 you first dial access code 820 then the extension number 5000. In Site 1 you would configure:

```
number_initiate -numbertype en -number 810
number_initiate -numbertype ed -number 820
number_initiate -numbertype ed -number 830
number_data_initiate -externalnumber 820 -minlength 7 -maxlength 7
number_data_initiate -externalnumber 830 -minlength 7 -maxlength 7
RODDI:DEST=820,ROU=x,SRT=1 or 4,ADC=xxx6xxx...;
RODDI:DEST=830,ROU=y,SRT=1 or 4,ADC=xxx6xxx...;
```

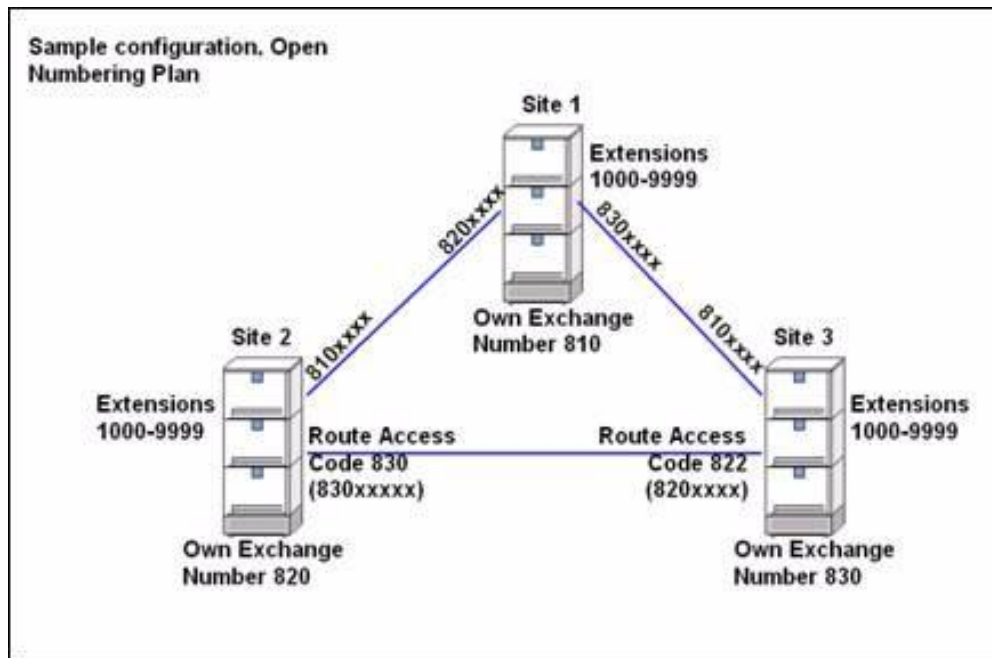


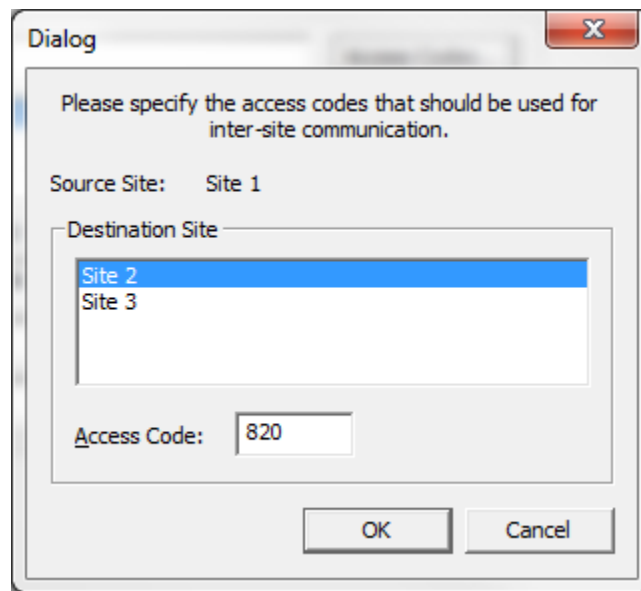
Figure 10: Open numbering plan

The ADC parameter should state the appropriate Type of Number (TON) for the calling private number. This is so that we can set the Exchange Number for Private Network correctly using the ROND! command:

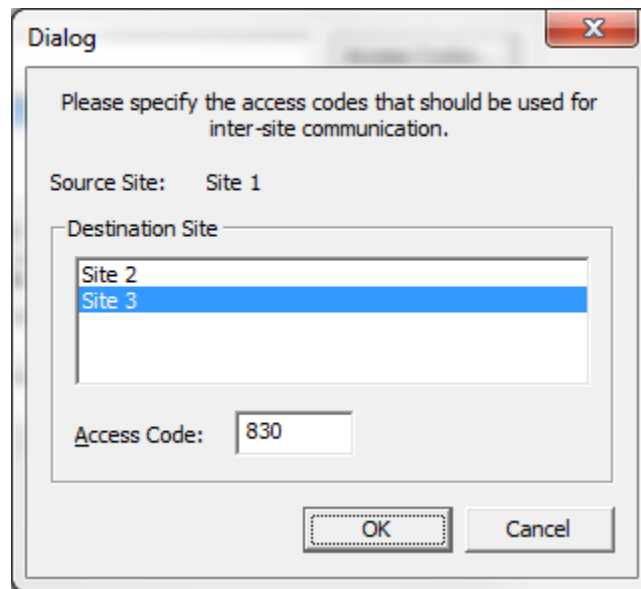
```
RONDI:ROU=x,EXNOPR=6-810; RONDI:ROU=y,EXNOPR=6-810;
```

This would set the TON to Local Private, and prefix the calling number, 4000, with 810 so that the called extension 5000 would see 8104000 as the calling party.

These Access codes have to be configured in the MiCC Enterprise Setup Utility. For each site, the Access codes needed to reach the other sites from this site has to be entered. So for Site 1, the data in Figure 11 and Figure 12 below has to be entered.



**Figure 11: Data for Site 2**



**Figure 12: Data for Site 3**

Sites 2 and 3 must be configured in the same way.

### Mixed Numbering Plan

In the example in Figure 13 below, when an extension in Site 1 or 2 wants to call an extension in Site 3 or 4 it would dial 850xxx. Calls from Site 3 and 4 to Site 1 and 2 would dial 800xxxx.

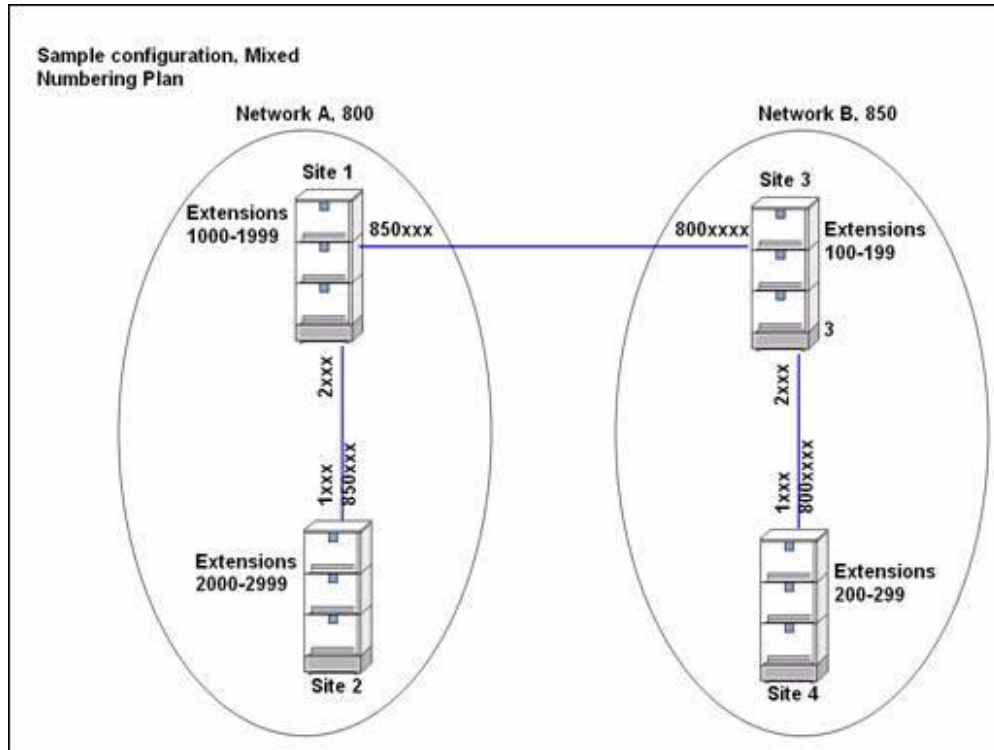


Figure 13: Mixed numbering plan

#### MX-ONE Telephony switch configuration for **Site 1**:

```
number_initiate -numbertype en -number 800
number_initiate -numbertype ec -number 2
number_initiate -numbertype ed -number 850
number_data_initiate -externalnumber 2 -minlength 4 -maxlength 4
number_data_initiate -externalnumber 850 -minlength 6 -maxlength 6
RODDI:ROU=x, DEST=2, SRT=1, ADC=x...;
RODDI:ROU=y, DEST=850, SRT=1 or 4, ADC=xxx6xxx...;
RONDI:ROU=y, EXNOPR=6-800;
```

#### MX-ONE Telephony switch configuration for **Site 2**:

```
number_initiate -numbertype en -number 800
number_initiate -numbertype ec -number 1
number_initiate -numbertype ed -number 850
number_data_initiate -externalnumber 1 -minlength 4 -maxlength 4
number_data_initiate -externalnumber 850 -minlength 6 -maxlength 6
RODDI:ROU=x, DEST=1, SRT=1, ADC=x...;
```

```
RODDI:ROU=y,DEST=850,SRT=1 or 4,ADC=xxx6xxx...;  
RONDI:ROU=y,EXNOPR=6-800;
```

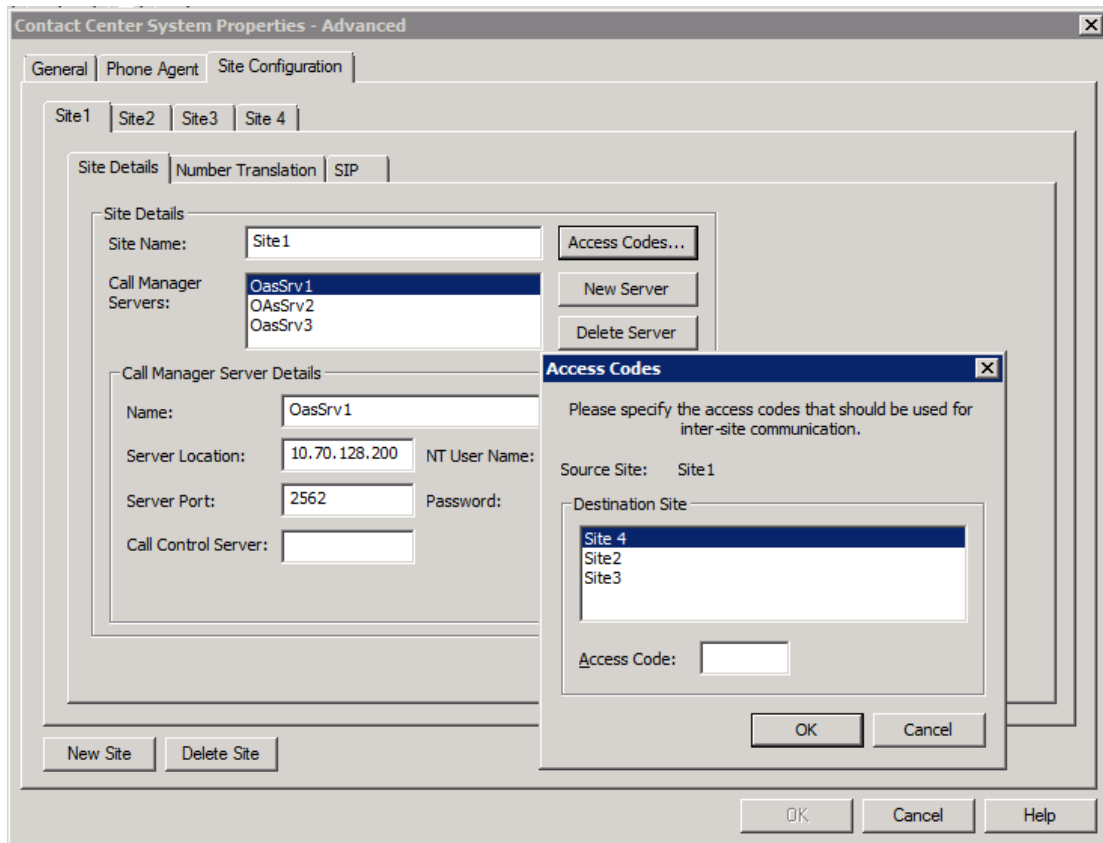
**MX-ONE Telephony switch configuration for Site 3:**

```
number_initiate -numbertype en -number 850  
number_initiate -numbertype ec -number 2  
number_initiate -numbertype ed -number 800  
number_data_initiate -externalnumber 2 -minlength 4 -maxlength 4  
number_data_initiate -externalnumber 800 -minlength 6 -maxlength 6  
RODDI:ROU=x,DEST=1,SRT=1,ADC=x...;  
RODDI:ROU=y,DEST=850,SRT=1 or 4,ADC=xxx6xxx...;  
RONDI:ROU=y,EXNOPR=6-800;
```

**MX-ONE Telephony switch configuration for Site 4:**

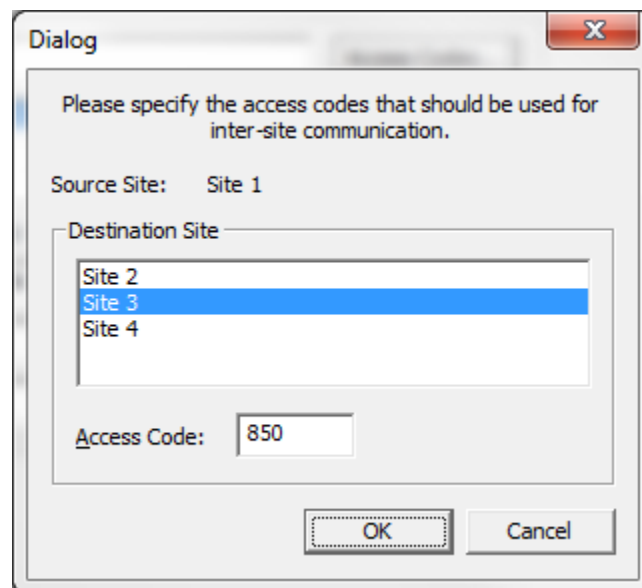
```
number_initiate -numbertype en -number 850  
number_initiate -numbertype ec -number 1  
number_initiate -numbertype ed -number 800  
number_data_initiate -externalnumber 1 -minlength 3 -maxlength 3  
number_data_initiate -externalnumber 800 -minlength 7 -maxlength 7  
RODDI:ROU=x,DEST=1,SRT=1,ADC=x...;  
RODDI:ROU=y,DEST=800,SRT=1 or 4,ADC=xxx6xxx...;  
RONDI:ROU=y,EXNOPR=6-850;
```

How the site information in Configuration Manager would look for Site 1 is presented in Figure 14 below.

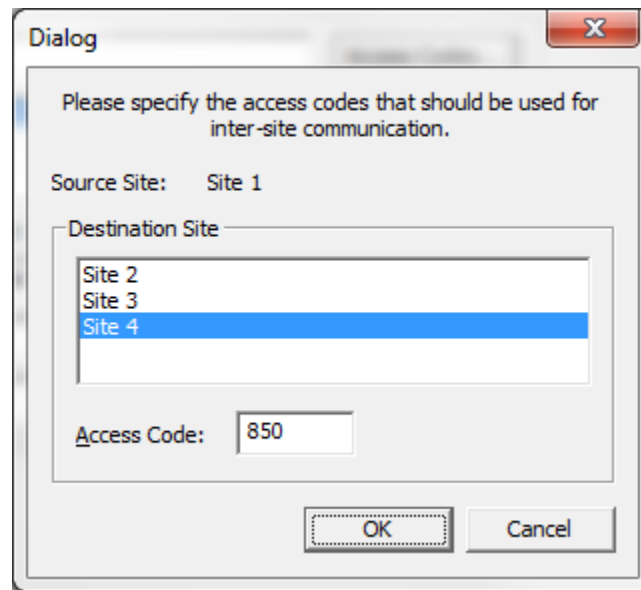


**Figure 14: Site 1 in Configuration Manager**

No Access Code needed for calls from Site 1 to Site 2. See Figure 15 and Figure 16 below for access codes for Site 3 and 4.



**Figure 15: Site 3 as destination site**



**Figure 16: Site 4 as destination site**

Access code 850 is needed for calls from Site 1 to Sites 3 and 4.

For Site 2, no Access code is needed for calls to Site 1. Access code 850 is needed for calls from Site 2 to Sites 3 and 4.

For Site 3, no Access code is needed for calls to Site 4. Access code 800 is needed for calls from Site 3 to Sites 1 and 2.

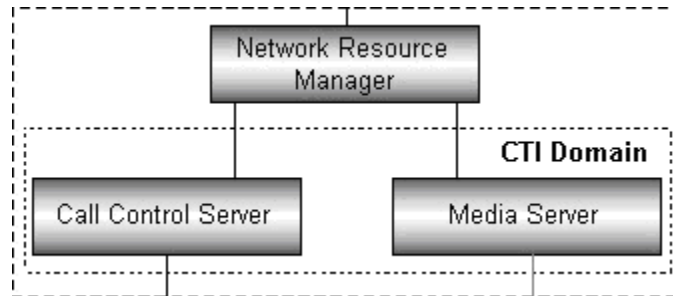
For Site 4, no Access code is needed for calls to Site 3. Access code 800 is needed for calls from Site 4 to Sites 1 and 2.

## OAS CONFIGURATION

Each Site in the VCC network must be configured with at least one OAS server to provide call control services for the agents located at this site. An OAS system consists of three main components:

- Call Control Server (CCS)
- Media Server (MS)
- Network Resource Manager (NRM)

In order to provide local call control, OAS needs to be installed with NRM and CCS, see Figure 17 below for an overview.



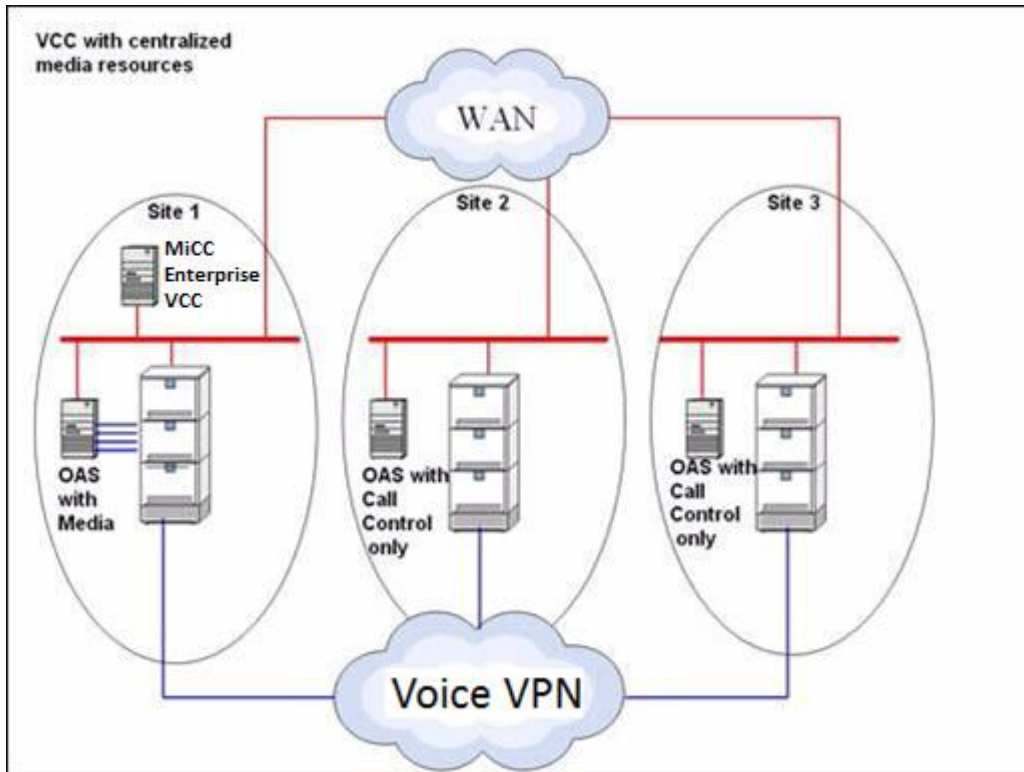
**Figure 17: Overview of the connection between the three main components in an OAS system**

How the OAS servers are configured for media services depend on a number of factors, such as:

- Where the calls enter the VCC and the location of the Service Access(es)
- Load balancing
- Redundancy
- Network utilization
- If Phone Agents will be used at the location or not

#### Centralized media resources

Consider the case where all calls enter the VCC at one location (site) and agents are located at this and two other sites. In this case, it could be beneficial to concentrate all media resources to the site where the calls enter the VCC. See Figure 18 below for a schematic overview.



**Figure 18: Overview of a Virtual Contact Center with centralized media resources**

A second OAS with additional Media resources could be installed at Site1 for redundancy and load balancing purposes.



Note: If Phone Agents will be used, they would all have to be located in the site with the centralized media resources, or a few media channels have to be installed at all sites where Phone Agents will be present. This is because the script used by Phone Agents to logon and off, and to make them ready or not ready, needs media resources to play messages and to receive DTMF input.

## Re-queue

In the scenario above, if an agent in Site 2 or 3 is presented with a call but does not answer, the call will be put back in a re-queue, and MiCC Enterprise will look for another agent to take the call. If you want the caller to be provided with repeated queue messages during this wait, then the re-queue device must be located in a Site with an OAS server with media services configured. It is recommended for this scenario that the re-queue device for the system is located in Site 1. By doing this, the call will be moved back to a CTI-group in the site where the call entered the network. No network resources will be occupied during the re-queue, and queue messages can be provided to the caller.

The screenshot shows the 'Contact Center System Properties' dialog box with the 'Call' tab selected. The 'Delayed Call Selection Rules' list includes 'Service Group Priority' (selected), 'Delayed Call Threshold', 'Abandoned Call Time Threshold', 'Lowest Service Level', 'Longest Waiting', and 'Voice Service Group Call Priority'. The 'Time-outs' section has 'Ring Time Supervision (sec.)' and 'Outbound Call Offer (sec.)' both set to 20. The 'Maximum Queue Time' section has 'Incoming Call' set to 1:00 (hh:mm) and 'Web Callback' set to 0 Days and 12:00 (hh:mm). The 'User Input' section has 'Termination Digit' set to '#' and 'Time-out (sec.)' set to 5. The 'Destinations' section has 'Default Destination' set to 3247 and 'Requeue Call Manager' set to 'Same as the Service Group'. A table lists 'Call Manager Name' and 'Requeue Device' for OasSrv1 through OasSrv6, with OasSrv1 mapped to BVDRequeue and others to <None>. The 'Advanced...' button is highlighted.

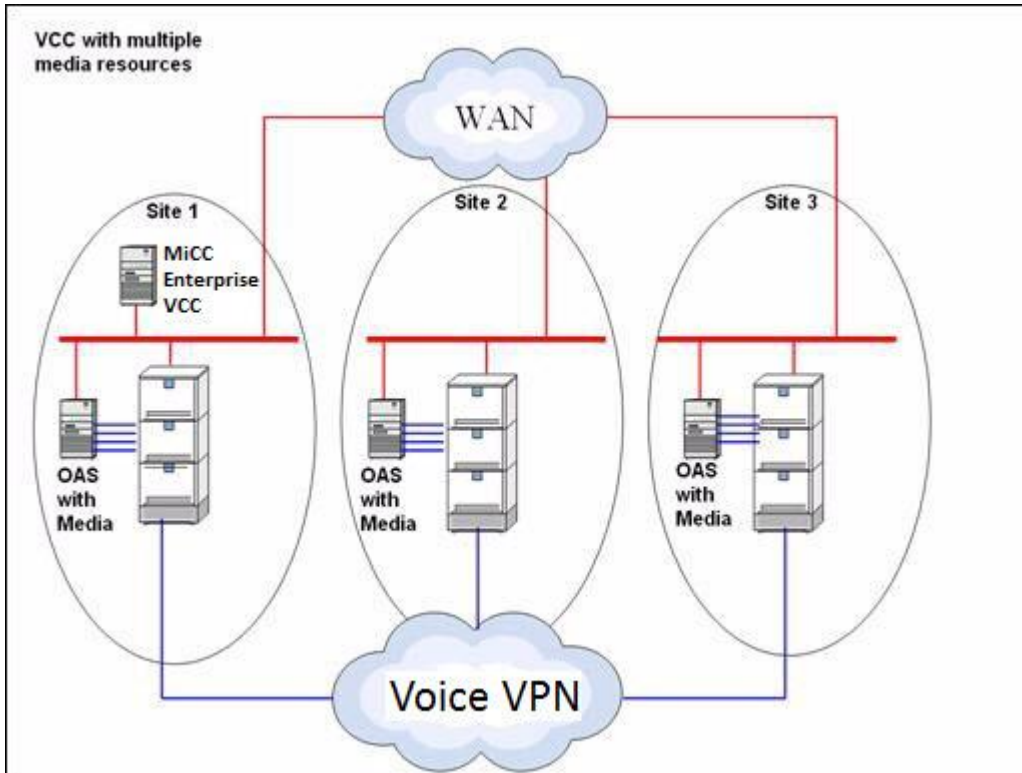
Call Manager Name	Requeue Device
OasSrv1	BVDRequeue
OasSrv4	<None>
OasSrv5	<None>
OasSrv6	<None>

**Figure 19: Contact Center System Properties**

In the Contact Center System Properties, you should configure the MiCC Enterprise VCC system to use the Re-queue device defined for the OAS server of the Service group, see Figure 19 above.

### De-centralized media resources

Another scenario could be that calls enter the VCC at multiple locations in the network, see schematic overview in Figure 20 below, and in order to save private network resources, it could be more feasible to place the Service Access for the call in the Site where the call enters the network, and have media resources at multiple locations within the VCC.



**Figure 20: VCC with Multiple Media Resources**

In the example above, all three sites have an OAS server with Media Services configured. One important consideration in these types of scenarios is that the OAS Media servers must be configured with the correct Play messages in order to achieve the wanted result. If calls entering a Service Access in Site 1 are handed over to, for example a Service Group called Sales, and also calls entering another Service Access in Site 3, is handed over to the same Service group (Sales), the Play messages for Queue messages and Repeat Queue messages must be configured in the same way in both the OAS servers. One way to guarantee this is to configure on one of the OAS servers and then copy the play.rep file to the other OAS server.

In the MiCC Enterprise system properties, you should configure the MiCC Enterprise VCC system to use the re-queue device defined for the OAS of the current Agent location, see Figure 19 above. This would eliminate sending the call back to the site where the call entered the VCC in case of re-queue.