



A MITEL
PRODUCT
GUIDE

MiContact Center Enterprise

SMS Gateway User Guide

Release 9.7

Document Version 1.0

November 2023

Notices

The information contained in this document is believed to be accurate in all respects but is not warranted by **Mitel Networks™ Corporation (MITEL®)**.

The information is subject to change without notice and should not be construed in any way as a commitment by Mitel or any of its affiliates or subsidiaries. Mitel and its affiliates and subsidiaries assume no responsibility for any errors or omissions in this document. Revisions of this document or new editions of it may be issued to incorporate such changes. No part of this document can be reproduced or transmitted in any form or by any means - electronic or mechanical - for any purpose without written permission from Mitel Networks Corporation.

Trademarks

The trademarks, service marks, logos and graphics (collectively “Trademarks”) appearing on Mitel's Internet sites or in its publications are registered and unregistered trademarks of Mitel Networks Corporation (MNC) or its subsidiaries (collectively "Mitel") or others. Use of the Trademarks is prohibited without the express consent from Mitel. Please contact our legal department at legal@mitel.com for additional information. For a list of the worldwide Mitel Networks Corporation registered trademarks, please refer to the website: <http://www.mitel.com/trademarks>.

®,™ Trademark of Mitel Networks Corporation

© Copyright 2023, Mitel Networks Corporation All rights reserved

INTRODUCTION

The Short Message Service (SMS) Gateway provides a solution for managing SMS messages in the MiCC Enterprise system. The SMS Gateway service interacts with one or more SMS modems, or an SMS Center, to send and receive SMS messages.

MiCC Enterprise and standalone Script Manager can use the Gateway to send and receive SMS messages independent of which message center the gateway is using. Using MiCC Enterprise Script Manager, it is possible to make routing decisions for incoming SMS messages just like any other media type. SMS messages can be handled in Script Manager by the script or routed to a SMS Service Group to select a suitable agent to handle the SMS message.

SYSTEM ARCHITECTURE AND COMPONENTS

The SMS Gateway is installed by running the SMS Gateway installation. SMS Gateway can be installed on a server separate from the MiCC Enterprise or Script Manager server. It is also possible to install SMS Gateway together with one or both MiCC Enterprise and Script Manager on the same server.

See Figure 1 for an overview of the system architecture and components.

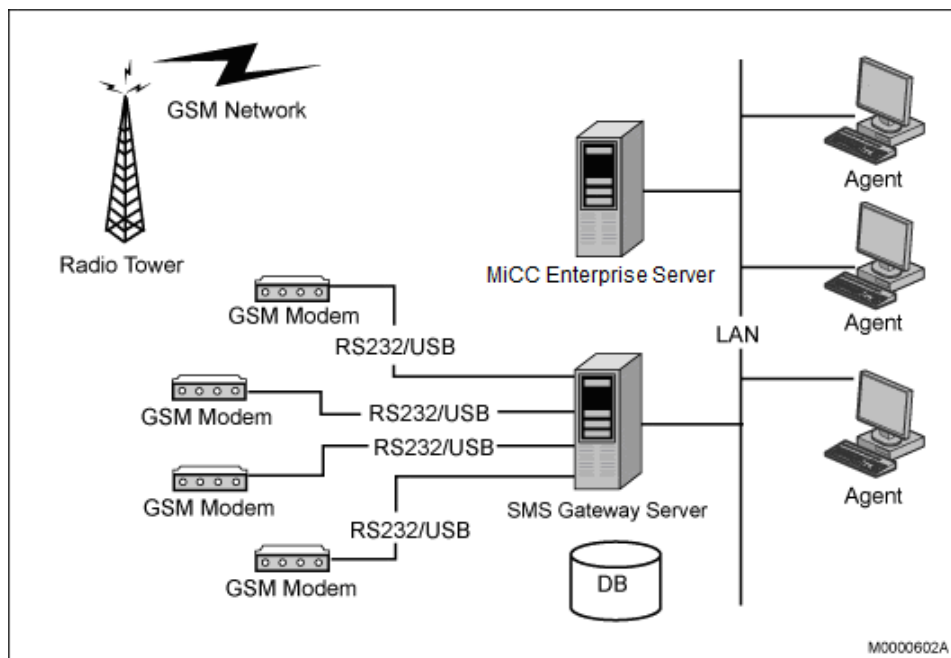

Figure 1: SMS Gateway Architecture.

SMS GATEWAY COMPONENTS

SMS Gateway consists of two services, one database, and a configuration application.

SMS GATEWAY CONFIGURATION SERVICE

The SMS Gateway Configuration Service provides the configuration data to the configuration application as well as to the SMS Gateway Service.

SMS GATEWAY SERVICE

SMS Gateway Service is the core service, interacting with the SMS modem or the SMS Center. Based on the configuration of the SMS-G provided by the SMS Gateway Configuration Service, it interacts with a SMS modem(s) or a SMS Center. Only one configuration can be used at a time, and this is based on the installed license.

SMS GATEWAY DATABASE

SMS Gateway database is created during installation. The database is used to maintain the list of SMS messages that have not yet been handled by the application. This enables the SMS Gateway Service to recover SMS messages in case the system goes down before the SMS messages are answered.

SMS GATEWAY CONFIGURATION APPLICATION

SMS Gateway Configuration Application allows the user to configure the SMS Gateway Service. The configuration application is installed on the same server as the SMS Gateway services. It allows the user to configure the SMS Center and SMS modems. Both configurations are allowed, but only the configuration with licenses installed will be able to receive SMS messages at run time. See *SMS Gateway Configuration* for details.

COMPATIBILITY

The system requirements for the MiCC Enterprise SMS Gateway are the following:

- MiCC Enterprise (Script Manager optional).
- SMS Gateway services installed on Windows Server (refer to Note below for version compatibility).
- SQL Server (refer to Note below for version compatibility).
- One or more SMS modems or a SMS Center.



Note: For the latest information on compatibility data regarding MiCC Enterprise and software please refer to the MiCC Enterprise System Engineering Guidelines, available in the CPI library and on the Doc Center accessible via MiConnect.

LICENSE REQUIREMENT

The SMS Gateway Service uses the Enterprise License Manager (ELM) to manage licenses. ELM can only be installed on one PC in the network. Refer to the *Enterprise License Manager* for details.

SMS MODEM

If the SMS Gateway Service uses SMS modems to send and receive SMS messages, it requires one modem port license per SMS modem.



Note: If both SMS-C and SMS modem licenses are installed in the system, the SMS modem license will take precedence. To force the SMS-C license to take precedence, add the Windows Registry value HKLM\Software\WOW6432Node\Mitel\SMMSG\Server\SmsgSvc\UseSMSCLicense with type = REG_DWORD and set the value to 1. Note that the SMS Gateway Service must be restarted for this value to take effect.

SMS-C

If the SMS Gateway Services uses a SMS Center to send and receive SMS messages, a SMS Center site license is required.

INSTALLATION

The MiCC Enterprise SMS Gateway Server is installed separately from the MiCC Enterprise installation. The SMS Gateway installation can be found on the MiCC Enterprise DVD in the SMMSG folder. To integrate the SMS feature to MiCC Enterprise or standalone Script Manager, the location of the SMS Gateway Server must be entered during MiCC Enterprise installation. Otherwise, the SMS Gateway Server name can be updated via the MiCC Enterprise Setup utility. For standalone Script Manager, the SMS Gateway Server name can be updated via Script Manager Configuration.



Note: In order for the SMS Gateway Service to run properly, either the SMS Service Center site license or SMS modem port licenses must be installed.

HARDWARE CONFIGURATION

When software installation is complete, it is necessary to configure the hardware to be used by the SMS Gateway Server. You should determine if the SMS Gateway Service will be using SMS modem(s) or a SMS Center.

SUPPORTED SMS MODEMS

Any SMS modem that supports SMS AT command set in PDU mode can be used. Text mode is not supported. The SMS modem should either have a COM port serial port interface or a virtual COM port via USB.

The SMS modems must be connected to the PC where the SMS Gateway Server is running. Refer to the modem manual for the hardware installation.

SIM CARD

You are provided a SIM (Subscriber Identity Module) card from your network operator. The SIM card contains, for example, information about your telephone number and the services included in your subscription. The Service Center Address can be obtained from your service provider. You will need both the telephone number and Service Center Address to configure the SMS Gateway Server. For instructions on installation of the SIM card in the SMS modem, refer to the modem manual.



WARNING: The SMS Modem must be powered off before inserting or removing a SIM card.

TESTING THE SMS MODEM

The light indicators on the modem will indicate the connectivity status and the network signal strength. Refer to your modem manual regarding how to interpret the light indicators.

SMS SERVICE CENTER

A service agreement must be made with the SMS Service Center. The location / IP address, port number, system ID and password must be provided from the service center. All the SMS addresses configured in the SMS Gateway configuration must be associated with the same system ID and password.

The SMS Service Center must support the SMPP V3.4, V4.0 or V5.0 protocol.

SMS GATEWAY CONFIGURATION APPLICATION

To use the SMS Gateway Configuration application, do the following:

1. From the Windows Start menu, select **Programs, Mitel SMS Gateway and Configuration**. The **SMS Gateway Properties** dialog box appears, consisting of three tabs; **General**, **SMS Center** and **GSM Modems**
2. The General tab appears by default, see Figure 2. Configure database settings and other properties. See Table 1 for a description of the fields on this tab.

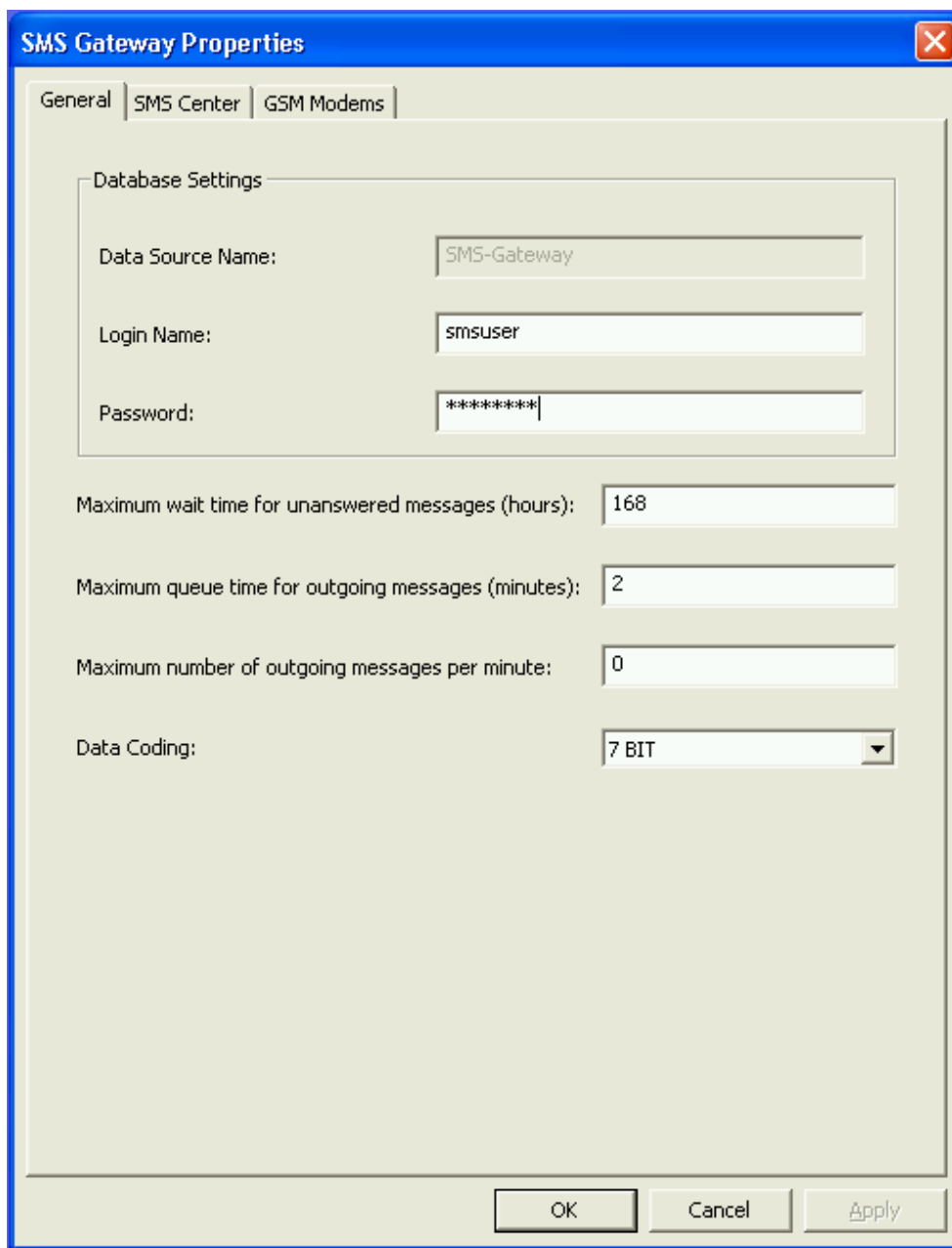

The screenshot shows the 'SMS Gateway Properties' dialog box with the 'General' tab selected. The dialog has three tabs: 'General', 'SMS Center', and 'GSM Modems'. The 'General' tab contains the following fields:

- Database Settings:**
 - Data Source Name: SMS-Gateway
 - Login Name: smsuser
 - Password: *****
- Maximum wait time for unanswered messages (hours): 168
- Maximum queue time for outgoing messages (minutes): 2
- Maximum number of outgoing messages per minute: 0
- Data Coding: 7 BIT (dropdown menu)

At the bottom of the dialog are three buttons: 'OK', 'Cancel', and 'Apply'.

Figure 2: General Tab

Table 1: Fields on General Tab

OBJECT	DESCRIPTION
Data Source Name text box	The data source name of the SMS Gateway database. This is configured during installation, and it is disabled for input.
Login Name text box	The login name for the SQL database server.
Password text box	The password to login to the SQL database server.
Maximum wait time for unanswered messages (hours) text box	The maximum wait time in hours that an incoming SMS will wait for a reply. The SMS Gateway will retain the incoming SMS messages until there is a reply or the message is deleted by the application. The default is 7 days (168 hours).
Maximum queue time for outgoing messages (minutes) text box	The maximum number of minutes that an outgoing SMS will be queued before it is discarded.
Maximum number of outgoing messages per minute text box	The maximum number of outgoing messages that can be sent in one minute. This is the throttle rate from your provider. Check with your service provider for the throttle rate. The default is set to 0. This means the throttle rate is not used.
Data Coding drop-down list	Data Coding of the SMS messages. Valid values are: 7 BIT 8 BIT UNICODE The default is 7 BIT.

3. Complete the necessary information. Click **OK** to save new settings.
4. If using SMS Center, select **SMS Center** tab, to configure the connection parameters. See Figure 3 and Table 2 for a description. Check with your SMS Center to obtain the configuration information.

The image shows a screenshot of the "SMS Gateway Properties" dialog box, specifically the "SMS Center" tab. The dialog has a blue title bar with the text "SMS Gateway Properties" and a close button (X) in the top right corner. Below the title bar are three tabs: "General", "SMS Center", and "GSM Modems". The "SMS Center" tab is selected.

The "SMS Center" tab contains several sections of configuration fields:

- SMSC**: A group box containing six text input fields:
 - Location: (empty)
 - Port: (0)
 - System Id: (empty)
 - Password: (empty)
 - Alternate Receiver System Id: (empty)
 - Alternate Receiver Password: (empty)
- Information Used When Binding With SMSC**: A group box containing three dropdown menus:
 - Type Of Number: (Unknown)
 - Numbering Plan Indicator: (Unknown)
 - System Type: (empty)
- Information Used When Sending Message**: A group box containing:
 - An unchecked checkbox labeled "Auto Detect Destination Address".
 - A text input field for "Service Type:" (empty).
- Two additional text input fields:
 - "Unsupported SMS Message Text:" (empty)
 - "Status Check Interval (ms):" (30000)

At the bottom of the dialog are three buttons: "OK", "Cancel", and "Apply".

Figure 3: SMS Center Tab

Table 2: Fields on SMS Center Tab

OBJECT	DESCRIPTION
Location text box	The SMS Center IP address or server name.
Port text box	The port number used for connecting to the SMS Center.
System ID text box	An identification of the SMS Center.
Password text box	The password for connecting to the SMS Center. A maximum of 8 characters can be entered.
Alternate Receiver System ID text box	Used to authenticate the connection to an SMS- C. Enter the System Id if the SMS-C requires a separate System Id for receiving SMS messages.
Alternate Receiver Password text box	Enter the password for receiving SMS messages. A maximum of 8 characters can be entered.
Type of Number drop-down list	The type of number. Valid values are: 0 – Unknown 1 – International 2 – National 3 – Network Specific 4 – Subscriber Number 5 – Alphanumeric 6 – Abbreviated The default is Unknown.
Numbering Plan Indicator drop- down list	The Numbering Plan Indicator. Valid values are: 0 – Unknown 1 – ISDN (E163/E164) 3 – Data (X.121) 4 – Telex (F.69) 5 – Land Mobile (E.212) 8 – National 9 – Private 10 – ERMES 13 – Internet (IP) 18 – WAP Client Id (to be defined by WAP Forum) The default is Unknown.
System Type text box	The type of external short message entity (ESME) that is binding to the SMS center. This field is optional. Some SMS Centers may not require the ESME to provide this information. In this case, this field can be left blank. Check with your SMS Center whether this field is needed. The default value is blank.
Auto Detect Destination Address option box	Automatically detects the number type and numbering plan. The default is unchecked.

OBJECT	DESCRIPTION
Service Type text box	<p>This parameter can be used to indicate the SMS application service associated with the message. This field is optional. The default is blank.</p> <p>The following generic services are defined:</p> <ul style="list-style-type: none"> "CMT" - Cellular messaging "CPT" - Cellular Paging "VMN" - Voice Mail Notification "VMA" - Voice Mail Alerting "WAP" – Wireless Application Protocol "USSD" - Unstructured Supplementary Services Data "CBS" – Cell Broadcast Service "GUTS" - Generic UDP Transport Service
Unsupported SMS Message Text text box	<p>If an SMS is received with formatting that is unsupported, the SMS Gateway will forward the SMS sender's number to the agent along with the text defined in the Unsupported SMS Message Text field. If no text is entered, the following text will be used : Unsupported message received</p>
Status Check Interval (ms) text box	<p>The interval in milliseconds that the SMS Gateway checks the connection to the SMS Center. This value should be less than the time out value from the SMS Center. Check with your provider for the time out value. The default value is 30000 ms.</p>

5. Complete the necessary information, and click **OK** to save the settings.
6. Click on the **GSM Modems** tab if you are using SMS modems, to configure the connection parameters. See Figure 4 and Table 3 for a description. Check with your network service provider to obtain the configuration information.
7. Complete the necessary information, and click **OK** to save the settings.

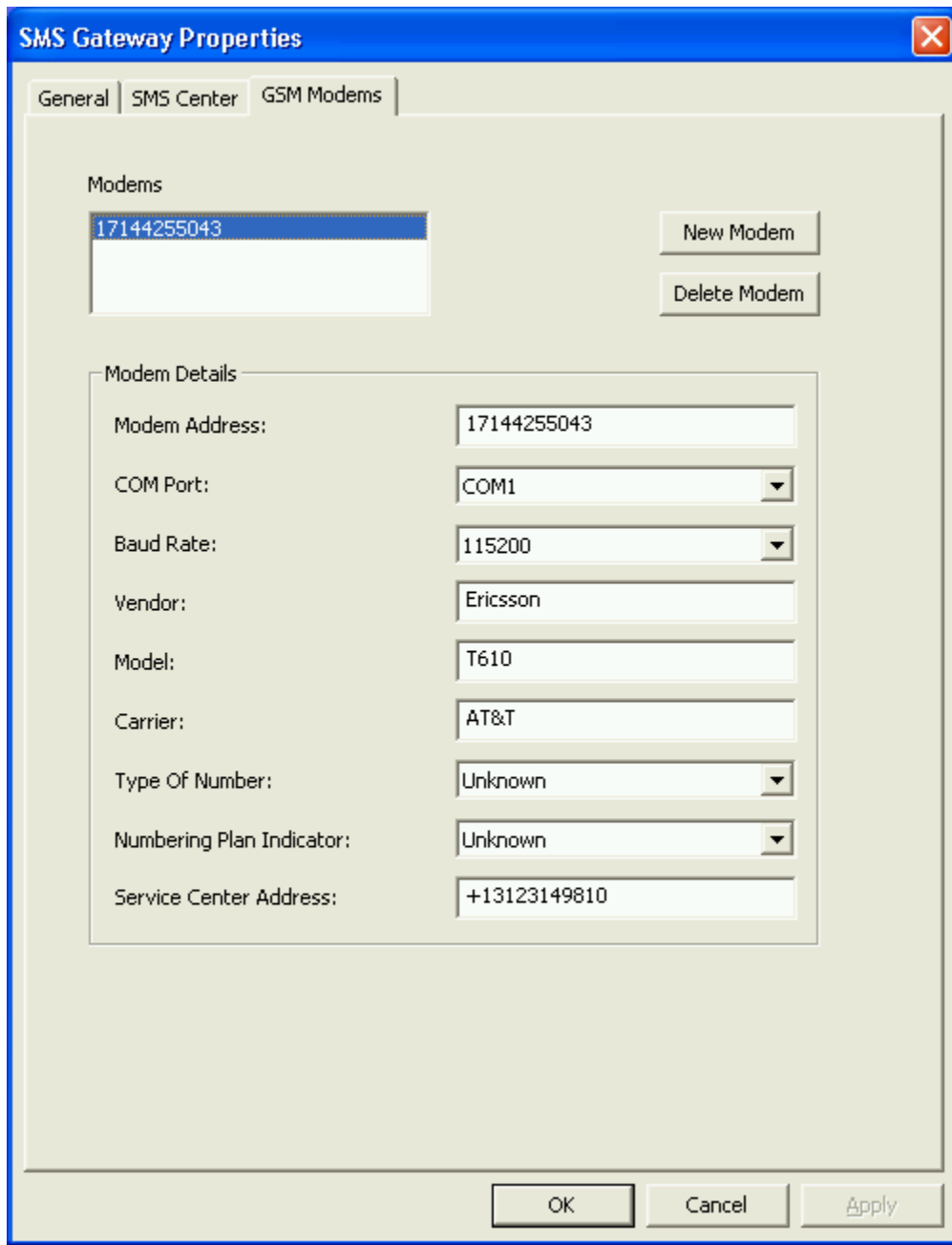

Figure 4: GSM ModemsTab

Table 3: Fields on GSM Modems Tab

OBJECT	DESCRIPTION
Modems list box	The Modems list box lists the modems that have been configured.
Modem Address text box	The phone number of the SIM card installed on the SMS modem.
COM Port drop-down list	A list of available COM ports. Select the COM port that is connected to the SMS modem.

OBJECT	DESCRIPTION
Baud Rate drop-down list	<p>A list of available baud rates. The baud rates depend on operator services.</p> <p>For Wavecom Fastrack Supreme and Maestro, the baud rate is 115200.</p>
Vendor text box	<p>Enter the name of the modem vendor. This is to identify the specific modem and it is an optional parameter.</p>
Model text box	<p>Enter the model name of the modem. This is to identify the specific modem and it is an optional parameter.</p>
Carrier text box	<p>Enter the name of the network operator. This is for the user to identify the network operator and it is an optional parameter.</p> <p>The default is blank.</p>
Type of Number drop-down list	<p>The type of number. Valid values are:</p> <ul style="list-style-type: none"> 0 – Unknown 1 – International 2 – National 3 – Network Specific 4 – Subscriber Number 5 – Alphanumeric 6 – Abbreviated <p>The default is Unknown.</p>
Numbering Plan Indicator drop-down list	<p>Configures the type of numbering plan used. Valid values are:</p> <ul style="list-style-type: none"> 0 – Unknown 1 – ISDN (E163/E164) 3 – Data (X.121) 4 – Telex (F.69) 5 – Land Mobile (E.212) 8 – National 9 – Private 10 – ERMES 13 – Internet (IP) 18 – WAP Client Id (to be defined by WAP Forum) <p>The default is Unknown.</p>
Service Center Address text box	<p>The SMS center address provided from your network operator. Check with your network operator to obtain the Service Center Address.</p>

CAPACITY

The SMS Gateway supports up to 4 SMS modems. It has been verified to receive and send 50 SMS messages per minute.

For outbound SMS messages, the agent can enter up to 1024 characters in the message. Before it is submitted, the SMS Gateway will break up the message into smaller messages with a maximum of 160 characters for 7-bit encoding, or a maximum of 140 bytes for Unicode messages. It will then submit multiple messages until the full message text is sent.

For incoming messages, up to 255 characters are supported. If a larger message is received, it is truncated to 255 characters before being sent to the MiCC-E system.

LOG FILES

The SMS Gateway Service logs status and errors to the Windows Event Log, which can be viewed through the Event Viewer. Additionally, an error log file is maintained with warnings and errors. The log is named `smgsvc.log`, and is located at:

For 32 bit (x86) Windows OS:

```
C:\Program Files\Mitel\MiCC Enterprise\SMMSG\Log\
```

assuming the C drive is the installation drive.

For 64 bit Windows OS:

```
C:\Program Files (x86)\Mitel\MiCC Enterprise \SMMSG\Log\
```

assuming the C drive is the installation drive.

See section 2.2, Compatibility, for supported Windows OS.

REGISTRY SETTINGS

The registry entries in Table 4 are used by the SMS Gateway Service. For 32 bit (x86) Windows OS, all entries are located under the

key: `HKEY_LOCAL_MACHINE\SOFTWARE\Mitel\SMG\Server`

For 64 bit Windows OS, all entries are located under the key:

`HKEY_LOCAL_MACHINE\SOFTWARE\Wow6432Node\Mitel\SMG\Server`

See section 2.2, Compatibility, for supported Windows OS.

Table 4: Registry Entries

ENTRY	TYPE	DEFAULT	DESCRIPTION
CfgSvc\LogFilter	DWORD	0	Log filter for SMS Gateway Configuration Service.
CfgSvc\Port	DWORD	2771	TCP/IP port of the SMS Gateway Configuration Service
SMGSvc\LogFilter	DWORD	0	Log filter for SMS Gateway Service
SMGSvc\Port	DWORD	2770	TCP/IP port of the SMS Gateway Service

CONFIGURING TYPE OF NUMBER (TON) AND NUMBERING PLAN INDICATOR (NPI) SETTINGS

It is possible to override the TON and NPI values from the values set when binding with the SMS-C for submitted SMS messages by setting the following Registry values under the SMG\Server key:

ENTRY	TYPE	DEFAULT	DESCRIPTION
OutboundNPValue	DWORD	N/A	Sets the NPI value for the destination address in the outbound SMS packet to the configured value
OutboundTONValue	DWORD	N/A	Sets the TON value for the destination address in the outbound SMS packet to the configured value
SourceNPValue	DWORD	N/A	Sets the NPI value for the source address in the outbound SMS packet to the configured value
SourceTONValue	DWORD	N/A	Sets the TON value for the source address in the outbound SMS packet to the configured value

Note that the above settings will apply to all outbound SMS messages for the system. If MiCC-E components bind with the SMS Gateway using different device names, and different values are required for each device, the NPI and TON values can be configured in the Registry as follows:

- Under the SMSG\Server Registry key, create the registry key systems
- Under SMSG\Server\systems create a Registry key for each defined device name
- Under the device name, add the 4 values listed in the table above (OutboundNPValue, OutboundTONValue, SourceNPValue and SourceTONValue) and configure the correct NPI or TON value
- When SMS messages are submitted for that SMS device, the configured values will be used

As an example, if two device names are used to connect to the SMS Center, System1 and System2, the Registry should be configured as follows:

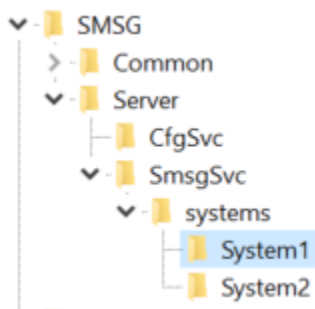

Under System1 and System2, the following values should be defined:

 OutboundNPValue	REG_DWORD	0x00000008 (8)
 OutboundTONValue	REG_DWORD	0x00000007 (7)
 SourceNPValue	REG_DWORD	0x00000006 (6)
 SourceTONValue	REG_DWORD	0x00000005 (5)



mitel.com

© Copyright 2020, Mitel Networks Corporation. All Rights Reserved. The Mitel word and logo are trademarks of Mitel Networks Corporation, including itself and subsidiaries and authorized entities. Any reference to third party trademarks are for reference only and Mitel makes no representation of ownership of these marks.