

Mitel MiContact Center Enterprise

OPEN APPLICATION SERVER
MX-ONE CONFIGURATION - USER GUIDE

Release 9.5



NOTICE

The information contained in this document is believed to be accurate in all respects but is not warranted by Mitel Networks™ Corporation (MITEL®). The information is subject to change without notice and should not be construed in any way as a commitment by Mitel or any of its affiliates or subsidiaries. Mitel and its affiliates and subsidiaries assume no responsibility for any errors or omissions in this document. Revisions of this document or new editions of it may be issued to incorporate such changes.

No part of this document can be reproduced or transmitted in any form or by any means - electronic or mechanical - for any purpose without written permission from Mitel Networks Corporation.

TRADEMARKS

The trademarks, service marks, logos and graphics (collectively "Trademarks") appearing on Mitel's Internet sites or in its publications are registered and unregistered trademarks of Mitel Networks Corporation (MNC) or its subsidiaries (collectively "Mitel") or others. Use of the Trademarks is prohibited without the express consent from Mitel. Please contact our legal department at legal@mitel.com for additional information. For a list of the worldwide Mitel Networks Corporation registered trademarks, please refer to the website: <http://www.mitel.com/trademarks>.

MX-ONE Configuration for Open Application Server User Guide
Release 9.5 – September 2020

®,™ Trademark of Mitel Networks Corporation
© Copyright 2020 Mitel Networks Corporation
All rights reserved

INTRODUCTION

Open Application Server (OAS) supports the MX-ONE PBX, the MX-ONE Telephony Server (TSE).

The PBX must be configured to support OAS to maximize available functionality. This document describes the configuration and software requirements to enable the telephone switch to support OAS:

- MX-ONE software requirements
- OAS Uniform Numbering Plan
- Configuring digital and analog extensions
- Configuring the NIU interface
- Configuring CTI groups
- Configuring routes and trunks
- Configuring the ISDN connection to the Media Server
- Configuring the analog extensions as Media Ports
- Configuring the IP extensions as Media Ports
- Configuring Agent Monitoring
- Configuring SIP Domain

MX-ONE SOFTWARE REQUIREMENTS

The Software versions supported by OAS are stated in the document Compatibility Matrix, MiContact Center Enterprise in the CPI or on the Info Channel.

OAS UNIFORM NUMBERING PLAN

In general, OAS requires a uniform numbering plan (referred to as a coordinated numbering plan in MX-ONE terminology). According to the uniform numbering plan, all devices to be monitored must be uniquely identified using the same number no matter where each is located in the private network. This applies to physical, logical, and virtual devices.

EXAMPLE

See Figure 1 below for an example of a network numbering plan that fulfills the OAS uniform numbering plan requirement. In this example, you dial the number 2XXX directly to reach any physical or logical device in Node 2 from Node 1. There can be no explicit node IDs or access codes (compare with area codes) to dial. Instead, the routing algorithm in the MX-ONE is configured to recognize the leading 2 in the dialed number to be an implicit access code for the route to Node 2.

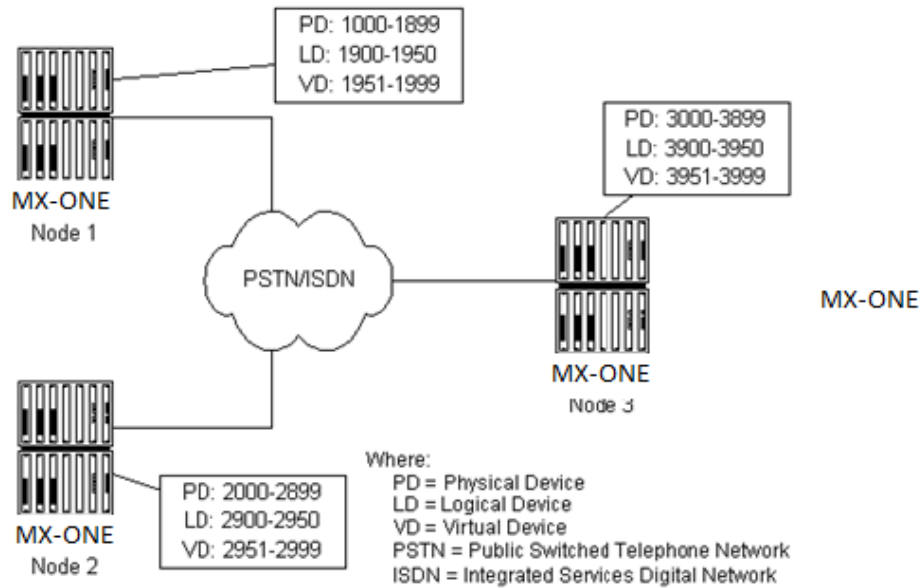

Figure 1: Sample network numbering plan

Virtual devices are represented by CTI group directory numbers in the MX-ONE. CTI groups representing virtual devices in different nodes follow the same numbering plan. In a single node, several CTI group numbers can be assigned to a single Basic Virtual Device (BVD).

In this example, the Virtual Device TelephonyBank is configured to be accessed (represented) through the CTI Group number range 1957 through 1960 in Node 1 (see the *OAS Software Configuration* section for details).



Note: For configuration of a multi node network in a MiContact Center Enterprise environment, see document *Virtual Contact Center Configuration*.

CONFIGURING DIGITAL AND ANALOG EXTENSIONS

All extensions in the OAS Network Resource Manager domain can be monitored and can provide a unified call ID to the application. These digital and analog extensions must be configured in the MX-ONE to meet the following conditions:

1. Calling party number and called party number can be sent over the private network
2. Calling party number and called party number can be displayed on the digital or IP/SIP telephone set display
3. This is accomplished by setting certain values in specific parameters of the following commands:
4. In the ADC parameter of the MX-ONE commands Extension Initiate (EXTEI) and Key System Extension Initiate (KSEXI)
5. In the SERV parameter of the Route Categories Initiate (ROCAI) command

See table 1 Digital and Analog Extension parameters on page 8 for a description of the parameters for the **KSEXI** and **EXTEI** commands that are relevant to OAS. For information about the **ROCAI** command, see table 8 Configuring Routes and Trunks on page 16.

Table 1: Digital and Analog Extension parameters

PARAMETER	DESCRIPTION	MANDATORY VALUE
Extension Initiate (EXTEI) Command		
ADC	Directory number presentation is allowed both internally and over a private network. (D3=0)	000000001
	Directory number of the extension is allowed to be sent to the public exchange. (D9=1)	000000001
Key System Extension Initiate (KSEXI) Command		
ADC	Directory number presentation is allowed both internally and over a private network. (D4=0)	0000000010000

PARAMETER	DESCRIPTION	MANDATORY VALUE
	Directory number of the extension is allowed to be sent to the public exchange. (D10=1)	00000000010000
IP, Mobile and Free Seating Extensions, General Extensions Initiate (GESPI) Command		
NPRES	D1=1 Request A-number from PSTN is not restricted. D2=0 Directory number presentation is allowed both internally and over a private network. D3=1 Directory number of the extension is allowed to be sent to the public exchange.	1010



Note: Multiple Directory Number (MDN) or Monitoring Key (MNS) - The Agent Directory Number cannot be assigned as a Multiple Directory Number (MDN) on other Digital Telephone Set (DTS) telephones, or as a Monitoring Key (MNS) on other Digital Telephone Set (DTS) or an IP-phone.

MX-ONE

EXTEI:DIR=1012,EQU=1-1-40-02,ITYPE=EL6,CAT=1,ADC=000000001;

KSEXI:DIR=1112,EQU=1-1-30-02,ITYPE=20,CAT=1,ADC=000000000100000;
GESPI:CSP=4,NPRES=1010,...;

For more information about the configuration of digital key system telephones and analog telephones, refer to MX-ONE documents *Operational Directions, Digital Key System Telephone, KS* and *Operational Directions, Analogue Extension, EX*.

CONFIGURING CSTA1 INTERFACE IN MX-ONE

MX-ONE TSE

INITIATE AND CONFIGURE CSTA PHASE I INTERFACE, APPLICATIONLINK

Each CTI (ApplicationLink) Server in the OAS is connected to the MX-ONE through a logical TCP/IP connection to one or more LIMs for call control of physical and logical devices.

For optimum performance, it is recommended that one connection be configured in every LIM that contains any object related to the CTI Server (that is, any telephone device or ACD/CTI group). This will distribute the load between the LIMs.

The CSTA interface to OAS is initiated using commands from Command Groups CS. For more detailed information about how to use these commands, refer to the MX-ONE document *Operational Instructions; Computer Supported Telecommunications Applications, CS*

COMMANDS

Following are examples of the cOMmands required to initiate and configure a CSTA interface:

1. Initiate a Link Group (identifying the ApplicationLink server) for each ApplicationLink server:

```
CSTLI:LGRP=link_group,LPORT=port,IP=ip_addr, LIM=lim_number,  
SERV=service_category;
```

where link_group is typically the host name of the ApplicationLink server, port is the TCP/IP port number used for communication (for example 2599), ip_addr is the IP address of the MX-ONE host (for example 195.100.113.121), lim_number is the LIM number and service_category to the link group for CSTA deflect and for sending encryption keys of H323/SIP extensions.

2. Use the following print commands to verify the initialization of the NIU and Link Group:

CSTLP; Prints all initiated Link Groups and their state



Note: The IP Address, port number and Link Group name configured here also must be configured in OAS. See document *OAS Software Configuration* for details.

INITIATE AND CONFIGURE CSTA PHASE III XML INTERFACE, X-LINK

The following sections are examples of the commands required to initiate and configure a CSTA Phase III XML interface, X-LINK.

1. Initiate a CSTA III interface:

```
csta -i --lim x --csta-serv zzzzzzzz
```

Computer Supported Telecommunications Applications Initiate.

Command Usage:

```
csta -i --lim x [ --port y ] --csta-serv zzzzzzzz
```

Where x is the LIM Number, y is the port number to be used (default is 8882) and z is the service-characteristics.

Example : **csta -i -lim 1 --port 8882 --csta-serv 00000000**



Note: The first byte of the csta-serv parameter must be set to 0 when OAS is used and the fifth byte should be set to 0 (Local View)

2. Print data for a CSTA III interface:

csta -p -lim x [--devices] [--servers]

The command is used to print the initialized CSTA Server's information or CSTA monitored device information for the stated LIMs.

Command Usage:

Servers: **csta -p -servers -lim x**

Devices: **csta -p -devices -lim x**

where x is the LIM number.

Examples: **csta -p -servers -lim 1**

csta -p -devices -lim 2

3. Terminate the CSTA Server:

csta -e --lim x -port y

where x is the LIM number and y is the port number

Example:

Terminate the CSTA Server in LIM 1.

csta -e --lim 1 -port 8882



Note: For the complete command description of the CSTA Phase III commands, refer to the document *Technical Reference Guide, Unix commands Description (201/190 82-ANF 901 14 Uen)* In the MX-ONE CPI library.

CONFIGURING CTI GROUPS

As described in table 4 OAS Uniform Numbering Plan on page 6, a virtual device in the OAS is mapped to a range of CTI groups per

MX-ONE node in the private network. All calls to be handled at the virtual device need to be assigned a queue record in the queue to the CTI group. The following factors need to be considered when configuring CTI groups:

3. There are a limited number of queue records per MX-ONE LIM.

Therefore, CTI groups must be configured carefully so that they will be assigned a proper number of queue records.

4. Since CTI groups are a special type of Automatic Call Distribution (ACD) queue, if regular ACD is used in the MX-ONE, the CTI groups available are shared with the number of ACD queues available.

The following list shows a number of parameters for queue records and

CTI groups parameters for MX-ONE.

- Queue Records per CTI Group
- Queue Records per LIM
- CTI Groups per LIM
- CTI Groups per System

For current capacity values of the parameters, see *MX-ONE Feature Matrix* in MX-ONE documentation.



Note: The values are shared between ACD queues and CTI groups. Each CTI group is initiated using the Automatic Call Distribution Group.

Initiate (ACGRI) command. For more information on how to use this and other ACD related commands, refer to the MX-ONE document *Operational Directions, Automatic Call Distribution, AC*. The parameters relevant to OAS are described in more detail in the following table.

Table 2: Parameter description

PARAMETER	DESCRIPTION	MANDATORY VALUE
Automatic Call Distribution Group Initiate (ACGRI) Command		
QUE	Dynamic queue is not used. (D1=0)	00232500125
	In MX-ONE, maximum queue length is nnn, where nnn = 0-250. (D5D6D7=250)	00232500125
	In MX-ONE TSE, the total maximum queue length in a LIM is 5000. That means that in order to initiate 1024 CTI groups per LIM, the average maximum queue length per CTI can not be more than 4 ($1024 \times 4 < 5000$)	00231000125 (example for MX-ONE TSE. max queue 100 which would allow for 50 CTI groups in a LIM)
SERV	<p>D1 = 1 CTI group is open for direct in-dialing traffic.</p> <p>D2 = 0 Characteristics for Swiss MFC</p> <p>D3 = 0 Music-on-Hold not provided</p> <p>1 Music-on-Wait is provided</p> <p>2 Music-on-Wait is provided only if recorded announcement has been provided</p> <p>3 Music-on-Hold is provided only for calls that reenter a queue after being deflected with maintained queue position</p> <p>Note: If music-on-wit is not provided then a queue tone or silence can be provided depending on the application system.</p> <p>D4 = 1 CTI group is classified as a CTI group.</p> <p>D5 = 0 Collect Call Category (Brazil)</p> <p>D6 = 0 Automatic extending not permitted for queued calls.</p> <p>1 Automatic extending permitted for queued calls.</p> <p>2 Automatic extending required for queued calls, regardless which extending option the operator has selected.</p>	103102 (Example)

EXAMPLES

- The following example initiates a group with 250 queue positions in a MX-ONE system:

ACGRI:GRP=3700,SERV=102100,TRAF=15,SEL=11005, QUE=00202500101,LIM=1;

CONFIGURING ROUTES AND TRUNKS

As described in OAS Uniform Numbering Plan, the network must be configured with a uniform numbering plan for the system to work properly. In addition, MX-ONE parameters concerned with routes and trunks between MX-ONE nodes in the private network also must be configured correctly. These parameters are set Using three different commands:

- Route Categories Initiate (ROCAI)
- Route Data Initiate (RODAI)
- Route Destination Data Initiate (RODDI)

For more information on how to use these commands, refer to the

MX-ONE document Operational Directions, Route Data, RO. The parameters relevant to OAS are described in the following table.

Table 3: Parameter description

PARAMETER	DESCRIPTION	MANDATORY VALUE
Route Categories Initiate (ROCAI) Command		
SIG	Network services are enabled for the routes between MX-ONEs. (D12=1)	511110100031
SERV	Presentation of called and calling party number is controlled by the called party's presentation category. (D8=0)	3110000000
Route Data Initiate (RODAI) Command		
VARI	Support of UUS services is set to no request service in the configuration of both ends of the route. (D2=5, D3=4) ECMA QSIG is selected, general protocol updates is set to no, and DSS1 network side is not supported. (D4=0)	05400000

PARAMETER	DESCRIPTION	MANDATORY VALUE
VARO	<p>D1=0 UI-frames are not supported, ECMA QSIG is used.</p> <p>D2=6 Send connected number in connect message, permitted to send UUI information in alerting message, and no semi-permanent connection.</p> <p>No fixed connection between B-channel and external line. Choose one end as layer 1 primary, layer 2 NT1, layer 3 network (D3=3), and the other as layer 1 auxiliary, layer 2 NT2, layer 3 user side (D3=4). Type of external line is set to tie-line (D4=0 if a VCU is not used).</p>	06300000 or 06400000
VARC	<p>D7=1 Full ISDN functionality supported, don't send busy/congestion tone to cooperating exchange, and no limitation in the number of octets in UUI element.</p>	00000110
Route Destination Data Initiate (RODDI) Command		
ADC	<p>The mandatory value for this parameter differs depending on the patch (that is, CNI-<Level>) if any, associated with the version. The main difference among the versions is in the number of digits that are required; the descriptions for D2 through D5 remain the same for all versions, as indicated below.</p> <p>D2=5 Type of called private number is unknown private. D3=0 Type of calling public number is unknown public. D4=5 Type of calling private number is unknown private. D5=1 Supplementary services using UUI is allowed.</p> <p>In an MX-ONE the ADC parameter consists of 25 1505100000000250005000000 digits.</p>	

EXAMPLES

Following are examples of the ROCAI, RODAI, and RODDI commands for MX-ONE:

```
ROCAI:ROU=2,SEL=711000000000010,SIG=511110100031,  
TRAF=03151515,TRM=5,SERV=3110000000,DIST=30,DISL=128,NODG=0,BCAP=111111;
```

```
RODAI:ROU=2,TYPE=SL60,VARI=05400000,VARO=06300000,VARC=00000110,FILTER=  
NO;
```

```
RODDI:DEST=21,ROU=2,ADC=1505100000000250005000000,TRC=0,SRT=1,NUMACK=0;
```

RE-ROUTING CONSIDERATIONS

In order to avoid having external calls re-routed to e.g. an operator position when not answered in time by a MiCC Enterprise agent, make sure the 'Ring Time Supervision' time (set in the MiCC Enterprise System properties) shorter than the trunk re-route time as specified in the ASPAC parameter 37.

Or you could set the D1 value in the SEL parameter for the ROCAI command to NOT to include option 4, 'Rerouting on no answer or not available'.

You can also avoid this problem by disabling rerouting on no answer on the individual extensions used by the MiCC Enterprise agents. For generic extensions that is done by setting D3 to 1 (Rerouting blocked) in the ext-traf parameter for the extension_profile command. For non-generic extensions you set the D1 in the CDIV parameter to 1 (Do not allow rerouting).

CONFIGURING IP MEDIA PORTS

OAS supports IP Media Ports interfacing with the MX-ONE. The following sections describe how to initialize IP extensions in the MX-ONE so that they can be used as Media Ports.

CONFIGURING THE LOAD DISTRIBUTION FACILITY

The MX-ONE provides an Mitel-proprietary load distribution mechanism. Through this facility, it is able to determine which is the most suitable gatekeeper for every H.323 IP extension to register. This choice is made according to the network domain the endpoint belongs to and the individual load level of each gatekeeper. This facility can be configured by entering the following commands.

8. `ip_domain -i`
9. `ip_gatekeeper -c`

For more information on how to use these commands, refer to the MX-ONE document *Operational Directions, IP Extension, IP*. To print your work, type the following command:

`ip_gatekeeper -p`



Note: Keep track of this domain name. You will need it later when you configure the OAS IP Media Server. This name is not a TCP/IP domain name, but strictly a label for use by the MX-ONE and OAS. In systems that include IP-based extensions as well as this integration, the domain associated with the integration must be different from the domain used for the extensions.

INITIATING THE GENERIC EXTENSION DEFINITION

Initiate a generic definition that can be applied dynamically to the IP-based MX-ONE extensions. Assign this generic definition to the standard range of directory addresses set aside for IP Media Ports and associate it with the LIM on which the entry gatekeeper board is installed.

For example:

`extension -i -d 10000..10010 --csp 0 -l 1`



Note: For MX-ONE TSE, it is necessary to set D17=1 in the SERV parameter for the CSP used by the media port as it enables media ports as a forced gateway.

D17 : Unconditional forced Gateway:

0 - no (default)

1 - yes : States whether all the calls to/from IP extensions will be unconditionally forced gateway

To verify your work, type the following command:

```
extension -p -d 10000..10010
```

CREATING INDIVIDUAL EXTENSIONS

Designate the extensions that will be used as Media Ports. For example:

```
ip_extension -i -d 10000
```

To verify your work, type the following command:

```
ip_extension -p
```

ADJUSTING THE JITTER BUFFER SIZE

Depending on the characteristics of the network, you may need to adjust the size of the memory buffer that the system provides to protect against “jitter” distortion in the voice signals that it processes.

Examples of the commands used to set the Jitter Buffer to 150 ms are shown below:

The buffer size parameter can be set or modified in increments of ten milliseconds (ms)

```
ASPAC:PARNUM=191,PARVAL=15;
```

To verify your work, type the following command:

```
ASPAP:PARNUM=191;
```

CONFIGURING AGENT'S MONITORING

To support Agent Monitoring, Supervisor and Agent category as well as Route must be configured.



Note: By default, the supervisor can only monitor service calls. It is however possible to override the default setting to monitor agents on outgoing calls, internal calls and private incoming calls. This is set in the MiCC Enterprise configuration tool (SeCCfg) under the tab Agent Service, Allow Monitoring of Busy-Other Calls”.

SUPERVISOR CATEGORY

SERV (Service Category): D4D5 = 13

Intrusion characteristics

- 01 Permitted to initiate intrusion
- 02 Open for intrusion and reception of call waiting tone from another party.

Priority characteristics (Only if any intrusion characteristics have been started).

- 12 Priority on Intrusion = 3

extension_profile -p

Call waiting protection C (The C-party is the one in speech with the target of the Call Waiting request).

- 0 No call waiting tone.
- 1 Yes, call waiting tone.

Intrusion capability level (The intrusion requester's capability level which will be compared to the intruded and third party's intrusion protection level)

- 0 Intrusion request is not allowed.
- 1 Intrusion capability level 1.

- 2 Intrusion capability level 2.
- 3 Intrusion capability level 3 (highest).

AGENT CATEGORY

SERV (Service Category): D4D5 = 02

Intrusion characteristics

- 02 Open for intrusion and reception of call waiting tone from another party.

Priority characteristics (Only if any intrusion characteristics have been started)

- 00 Priority on intrusion = 0

extension_profile -p

ROUTE

SERV (Route Service Category) : D1 =2

Call Waiting Characteristics

- 2 Reception of call waiting tone permitted and intrusion permitted.

<rocap:rou=61;ROU=61, SEL=5110000010000010, TRM=5, SERV=2100030003, NODG=0
,DIST=30, DISL=128, TRAF=03151515

,SIG=511110000030, BCAP=001100;

ASPAP CONFIGURATION

Intrusion and call waiting characteristics for incoming external traffic is permitted:

ASPAC:PARNUM=26, PARVAL=1;

To verify your work, type the following command: `ASPAP:PARNUM=26;`

Permit intrusion and call waiting characteristics for incoming external traffic is allowed

`ASPAC:PARNUM=35, PARVAL=1;`

To verify your work, type the following command: `ASPAP : PARNUM=35 ;`

Intrusion from an extension or a PBX operator on a party with an external call is allowed

`ASPAC:PARNUM=36, PARVAL=1;`

To verify your work, type the following command: `ASPAP:PARNUM=36`

CONFIGURING IP DOMAIN

INITIATION OF IP DOMAIN IN MX-ONE TSE

If you are using H.323:
Initiate the domain name:

```
ip_domain -i --domain-name x --ip-net xxx.xxx.xxx.xxx/xx --packetization-interval x
```

--domain-name

This parameter corresponds to the name of the domain to be used while configuring Media Server in Open Application Server.

--ip-net

This parameter corresponds to the IP address of the Media Server plus the number of mask bits separated by a slash, /.

Example: 192.168.25.10/32

--packetization-interval

This parameter states the packetization interval. The parameter specifies the length of time in milliseconds represented by the media in a packet. The correct value is 30 ms of audio per RTP packet for any supported codec. The switch requires a single-value argument, (RTPPacketSize (p time) = 30). If, for example, packetization-interval is 20 ms, then IPMS will not work. See RFC3551 for more information regarding packetization interval.

If you are using SIP:

```
sip_domain --local-domain-name x --initiate
```

E.g.

```
sip_domain --local-domain-name mx-one.net --initiate
```

CONFIGURING VIRTUAL IP/SIP DEVICES TO BE USED BY PROGRESSIVE DIALING CAMPAIGNS

Progressive Campaign is the Concept of making continuous calls from OAS through Virtual IP/SIP extensions, and having only answered calls being sent to agents.

INITIATION OF VIRTUAL IP/SIP EXTENSION

Example

Initiate the directory number 654 as a virtual extension (VE):

```
ip_extension -i -d 654 --terminal-identity "sip:654@0.0.0.0" \  
--uri "sip:654@0.0.0.0"
```